

CHOOSING BRAKE CALIPERS FOR YOUR REACTION ARM BRAKE SYSTEM



HOW ABOUT A GMC PARKING
AND EMERGENCY BRAKE ?

27/10/2013

1

Objective

- To discuss the merits of the brake torque reaction arm system as applied to the GMC motorhome and choosing the size and type of brake calipers :

To optimize the GMC braking capability whether moving or stopped !

CHOOSING BRAKE CALIPERS FOR YOUR REACTION ARM BRAKE SYSTEM

- The reaction arm brake system has existed in one form or another for decades, originally looked at and developed to lessen strain on drive train components, i.e.. Drive shafts, spring shackles , U-Joints and springs.
- Motorcycles, performance cars, highway tractor trailers, buses have all used a version of reaction arm braking.

CHOOSING BRAKE CALIPERS FOR YOUR REACTION ARM BRAKE SYSTEM

- Looking at the forward dynamics of the GMC motorhome ; all vehicles pitch forward during braking , our coaches are no exception. This pitch forward phenomena is a result of the vehicles forward motion coupled with its center of gravity or more correctly its "center of mass in relation to its wheelbase".

And the common denominator here is ?

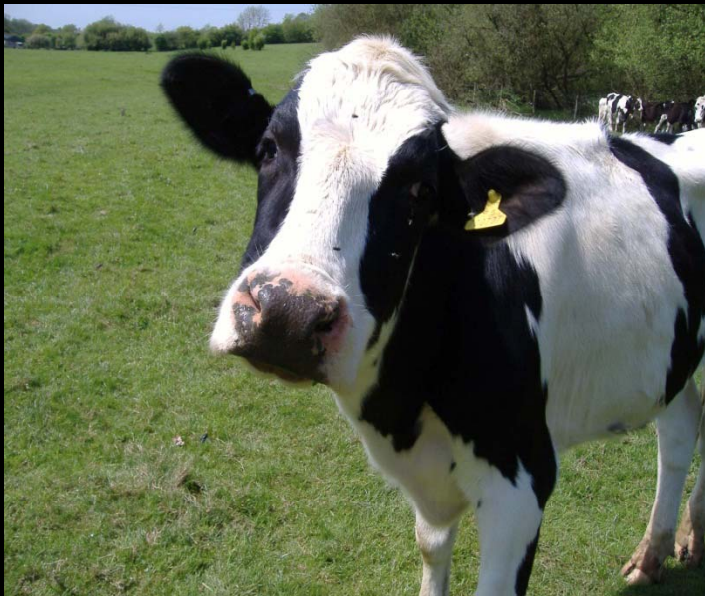

27/10/2013

5

CHOOSING BRAKE CALIPERS FOR YOUR REACTION ARM BRAKE SYSTEM

It matters not whether its our motorhome , a cow or Pamela Anderson, ALL will pitch forward during deceleration (some more than others !).

Our motorhomes are unique due to the leading / trailing arm rear suspension , this pitch forward tendency is amplified greatly and the accompanying weight shift on the wheels has serious implications on our braking balance.

CHOOSING BRAKE CALIPERS FOR YOUR REACTION ARM BRAKE SYSTEM

- *Photo of GMC showing static / dynamic brake balance and front / rear weights*

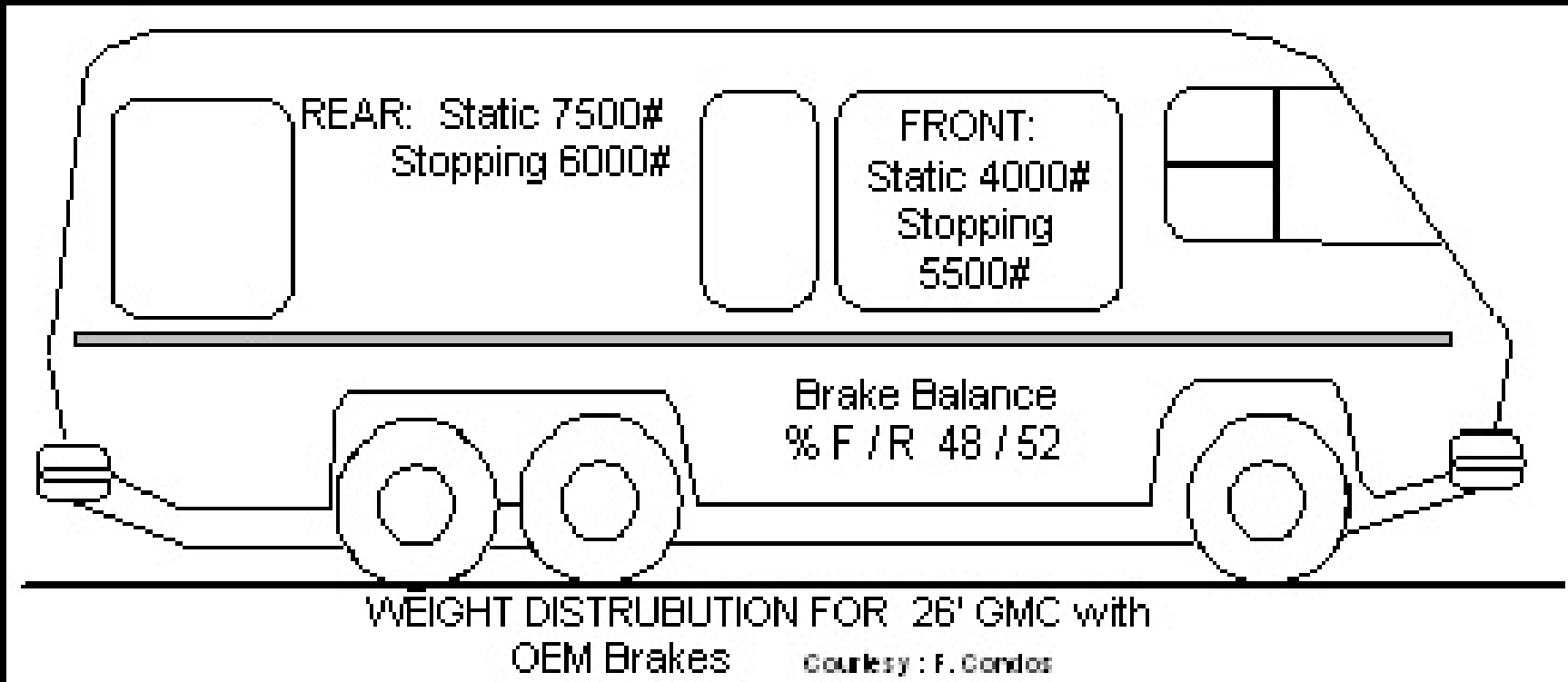

Weight transfer numbers at approx. 0.5 G

CHOOSING BRAKE CALIPERS FOR YOUR REACTION ARM BRAKE SYSTEM

- As can be seen below, 50% weight transfer to the front wheels and the rear most set of wheels only have approx. 350 # weight on each at 0.75 G's deceleration.

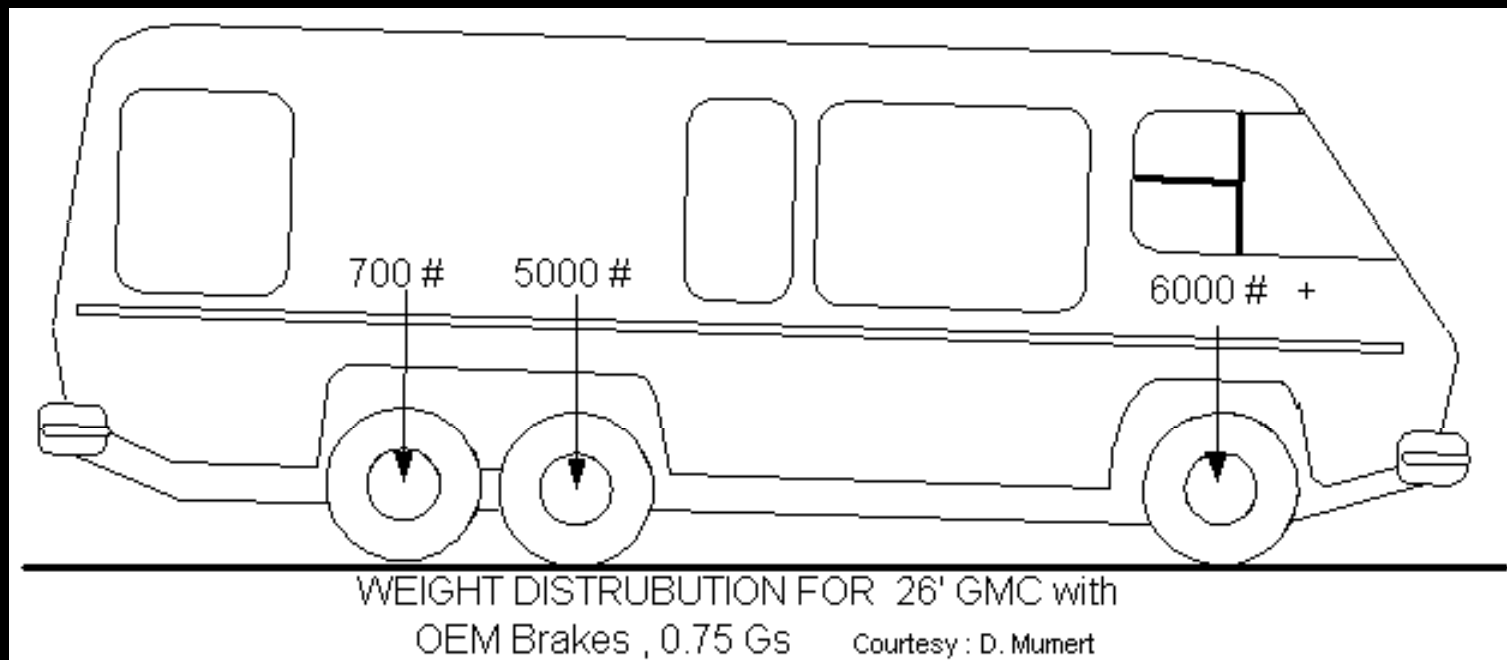

CHOOSING BRAKE CALIPERS FOR YOUR REACTION ARM BRAKE SYSTEM

- Norm Jestico from B.C. Canada " The ancient Brit." had begun a reaction arm project back in 2006 and actually brought it to the testing stage before he sadly passed away.
- Norm had the idea of rotationally floating the brake backing plates on the rear bogie arms and tying them back into the frame so one could eliminate the lifting energy created by the forward bogie when the brakes are applied, this would drastically reduce coach nosedive and back end lifting .

CHOOSING BRAKE CALIPERS FOR YOUR REACTION ARM BRAKE SYSTEM

Norm Jestico, April 13th. 2007

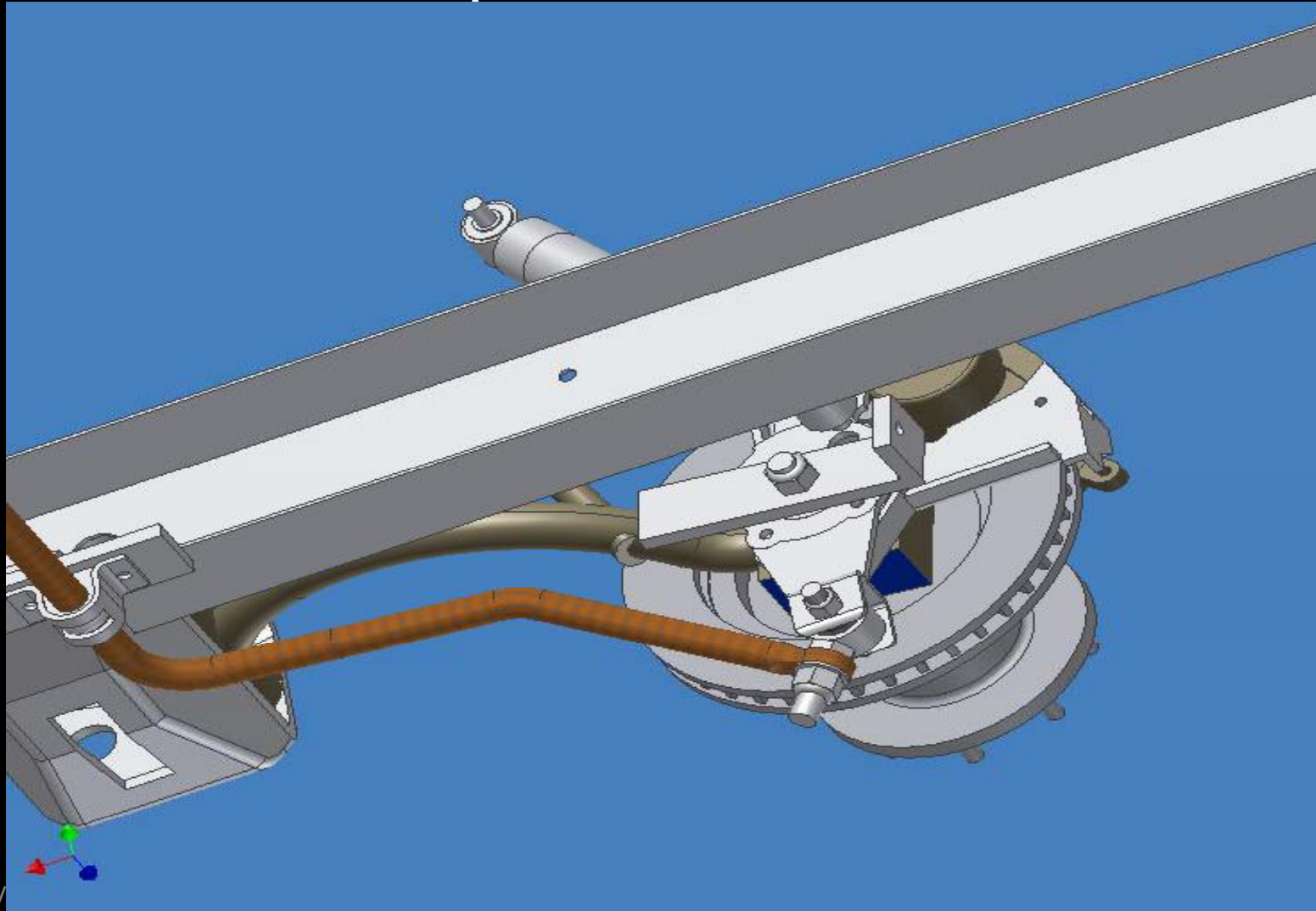

CHOOSING BRAKE CALIPERS FOR YOUR REACTION ARM BRAKE SYSTEM

Chuck Aulgur , who I'm sure you all know or have at least heard of "picked up the ball" and continued onward.

Chuck , Jim K. and Rick Flanagan began a development project to ascertain whether an economic case could be made to incorporate the system on the rear of the GMC motorhome.

CHOOSING BRAKE CALIPERS FOR YOUR REACTION ARM BRAKE SYSTEM

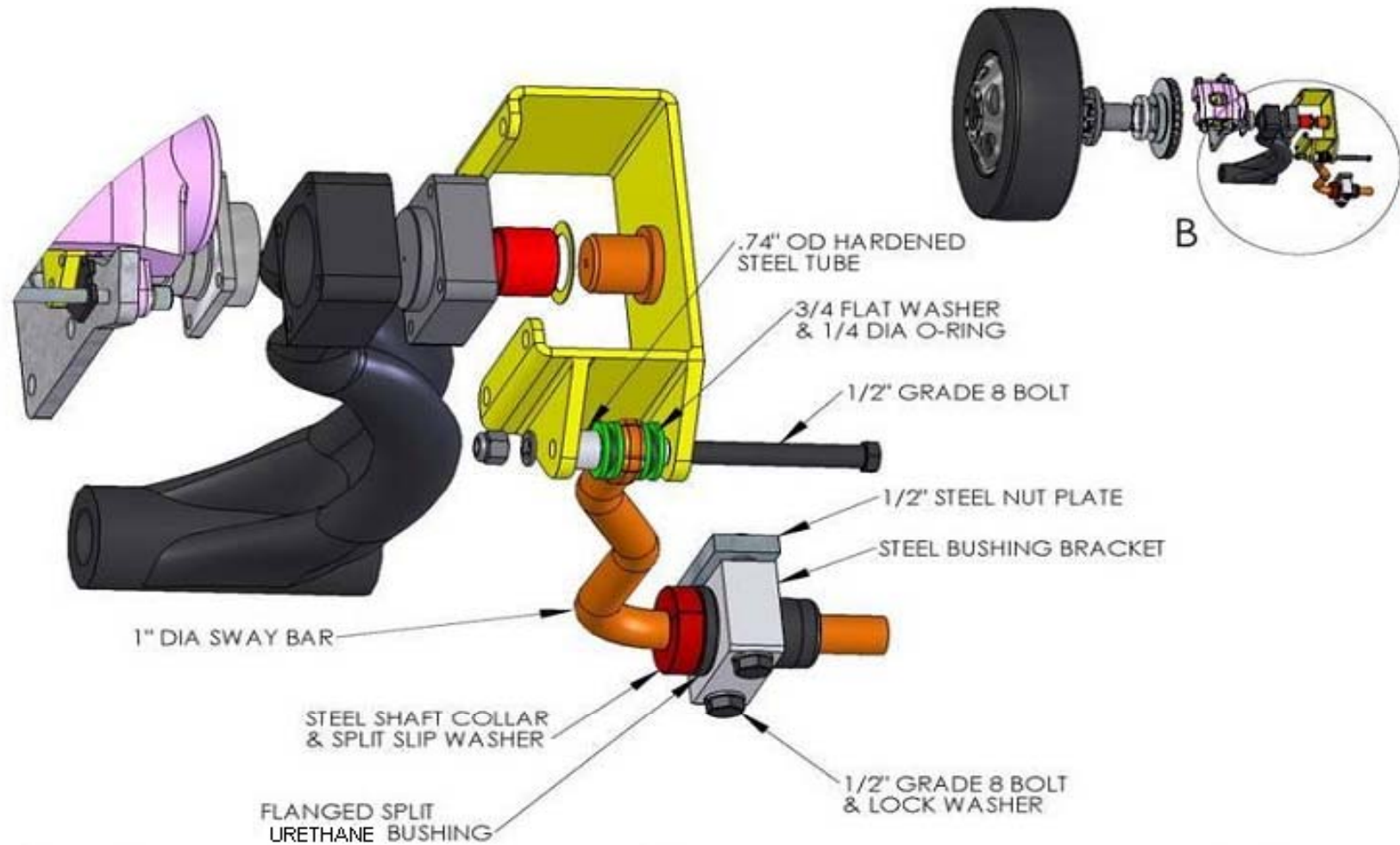

Aulger , Flanagan , Kanomata assembly

CHOOSING BRAKE CALIPERS FOR YOUR REACTION ARM BRAKE SYSTEM

- As can be appreciated , the idea and implementation of the reaction arm system for the GMC is more or less solidly in the public domain.
- There are more similarities between the Jestico and Aulgur assemblies than there is between the Aulgur and the Manny assembly.

CHOOSING BRAKE CALIPERS FOR YOUR REACTION ARM BRAKE SYSTEM

Manny's Kit Components



27/10/2013

CHOOSING BRAKE CALIPERS FOR YOUR REACTION ARM BRAKE SYSTEM



Manny's Torque box/plate, torque tube & bogie box anchor

27/10/2013

CHOOSING BRAKE CALIPERS FOR YOUR REACTION ARM BRAKE SYSTEM

- Since the bogie spindle alone dictates the machining operations required by the backing plates, AGAIN ; this necessity is pretty much public domain as well.
- However , while there was no intent to copy the Aulgur system, Manny would have benefited somewhat from the prior R & D and promotion done by the Applied GMC group.

CHOOSING BRAKE CALIPERS FOR YOUR REACTION ARM BRAKE SYSTEM

- Because of the current ongoing controversy regarding pricing and technical details regarding the two different systems, Kim on behalf of GMCMI asked me if I would attempt to explain the differences in overall cost.
- It also must be stressed here that almost all of the controversy has been “field” generated and has benefited no one !

CHOOSING BRAKE CALIPERS FOR YOUR REACTION ARM BRAKE SYSTEM

- Seeing that in " Polite company" one should shy away from discussing religion, politics , sex or money . In this case we are forced to discuss the economics behind the Jim K. and the Manny reaction arm systems.
- Both systems will more or less perform the same task , in that they transfer the lifting energy of the forward bogie to the frame of the coach, thereby eliminating the " pole vaulting" we experience upon braking.

CHOOSING BRAKE CALIPERS FOR YOUR REACTION ARM BRAKE SYSTEM

- Basically the price difference is attributed to three things :
- #1 , Research and development costs
and
- #2 , Outside manufacturing costs
and
- #3 , Technical detail costs

CHOOSING BRAKE CALIPERS FOR YOUR REACTION ARM BRAKE SYSTEM

- R & D is a very time consuming and costly proposition, In our case alone, the time and expense involved in implementing the Kelsey Hayes park brake caliper project amounted to approx. 2 years and slightly over \$10,000 . Ours was a relatively small project and only involved 2 people most of the time.

CHOOSING BRAKE CALIPERS FOR YOUR REACTION ARM BRAKE SYSTEM

- Summary of R & D costs:
 - A/ Draft , intermediate and final drawings
 - B/ Modeling and mockups
 - C/ Static and dynamic stress analysis
 - D/ Evaluating component counts
 - E/ Destructive and non-destructive tests
 - F/ Prototypes and testing of same
 - G/ P. Engineering approvals and " Stamps"
 - H/ Marketing and customer base evaluation
 - I/ Manufacturing economics, what can be done
" In – house" ?

CHOOSING BRAKE CALIPERS FOR YOUR REACTION ARM BRAKE SYSTEM

Manufacturing costs:

- " In-house " manufacturing costs
- 2nd. And 3rd. Party manufacturing costs
- Cost of raw materials , were they bought in sufficient quantities for " price breaks " ?
- Cost of purchased finished components.
- Plasma & Laser cutting.
- Milling, turning and jig manufacture.
- Welding & dye penetrant testing
- Final fitting and corrosion plating or painting
- Production and inventory spares.
- Production of manuals & instructions.

CHOOSING BRAKE CALIPERS FOR YOUR REACTION ARM BRAKE SYSTEM

- Manufacturing :
Essentially the same premise goes to the manufacturing process. There are those folk that will work 12 hours a day doing all or most of the necessary tasks themselves . This will make a vast difference in the cost of the final product . If 2nd and 3rd party costs are looked at ; the price difference is likely to be at least an "order of magnitude" higher.

CHOOSING BRAKE CALIPERS FOR YOUR REACTION ARM BRAKE SYSTEM

- Since you or I do not know what the agreement was between Jim and Manny when the Flanagan drawings passed hands , the proceeding explanations will have to suffice as to why there is a difference in price between the two systems. In the following technical assessment of the two systems , I will highlight further reasons for the difference in product pricing .

CHOOSING BRAKE CALIPERS FOR YOUR REACTION ARM BRAKE SYSTEM

- Make no mistake about it ; Jim and Manny are both great guys, we all know they have traveled all over the country helping people out, often at significant cost of time and money to themselves. Same as for phone information, they will spend considerable time convincing a potential customer as to what part he needs for his GMC only to have the customer go to Rock Auto to buy it. But they will still talk to the same customer when he calls again. In short they are really, really great guys; i.e.. The kind of guys that will go to town and get 2 "Hummers" and come back and give you one !

CHOOSING BRAKE CALIPERS FOR YOUR REACTION ARM BRAKE SYSTEM

It is clear to me that , neither of these two guys are charging their customers an unfair price in light of what each of their assemblies cost them to produce !



CHOOSING BRAKE CALIPERS FOR YOUR REACTION ARM BRAKE SYSTEM

On conclusion of looking at the various aspects of the R & D processes and the manufacturing processes, one can conclude that perhaps a small review of "Professional etiquette" by "all" the players might be in order.

CHOOSING BRAKE CALIPERS FOR YOUR REACTION ARM BRAKE SYSTEM

Addressing technical considerations regarding the two REACTION ARM SYSTEMS.

- #1 / Ease of field assembly of the kit.
- #2 / Conciseness of instructions for the kit.
- #3 / Fit and finish of kit components.
- #4/ Ease of field maintenance as it pertains to adjustment and lubrication.
- #5/ Choice of various calipers to suit the varying needs/wants of the GMC community.

CHOOSING BRAKE CALIPERS FOR YOUR REACTION ARM BRAKE SYSTEM

- Since I have not personally installed either kit, I can not offer any comment on actual installation.
- I have looked at Rick Flanagan's and Karen Bradley's instructions and found them to extremely well written and illustrated.
- There are significant differences in the component makeup of the two kits. This is something a prospective purchaser would have to review for themselves.
- Do the components have to be disassembled for routine maintenance and adjustment ?

CHOOSING BRAKE CALIPERS FOR YOUR REACTION ARM BRAKE SYSTEM

- As Karen B. mentioned in her draft installation manual that it was a “work in progress” the kit itself is also a “work in progress” , Manny uses a backing plate thickness of $\frac{1}{2}$ ” , this results in possible contact between the rotating hub and the plate. $\frac{7}{16}$ ” plate steel is dreadfully hard to find and is expensive, at least in Canada . When I did the torque box plates for George Z. for the K-H caliper , I had to mill a $\frac{1}{16}$ th of an inch off a $\frac{1}{2}$ ” plate.

CHOOSING BRAKE CALIPERS FOR YOUR REACTION ARM BRAKE SYSTEM

- A quick machining job on a lathe would provide a 4.0" diameter X 0.050" recess on the backing plate ensuring the hub will never contact it.
- Barring the machining step above, one could provide shims to shim out the hub "bearing pack" . This may or may not be advisable ?
- This will ensure the novice GMC'er would not mistake hub to backing plate "contact" as being the *same* as having the hub "bearing pack" being properly positioned .

CHOOSING BRAKE CALIPERS FOR YOUR REACTION ARM BRAKE SYSTEM

- The 1973 GMC coaches in particular seemed to have wider tolerances on the bogie spindle than did the later model years.
- This fact alone may explain the clearance problems noted in the field.

CHOOSING BRAKE CALIPERS FOR YOUR REACTION ARM BRAKE SYSTEM

- The Manny torque box $\frac{3}{4}$ " trunnion bolt may require some sort of lateral restraint to keep the torque tube centered. Easy fix if necessary.

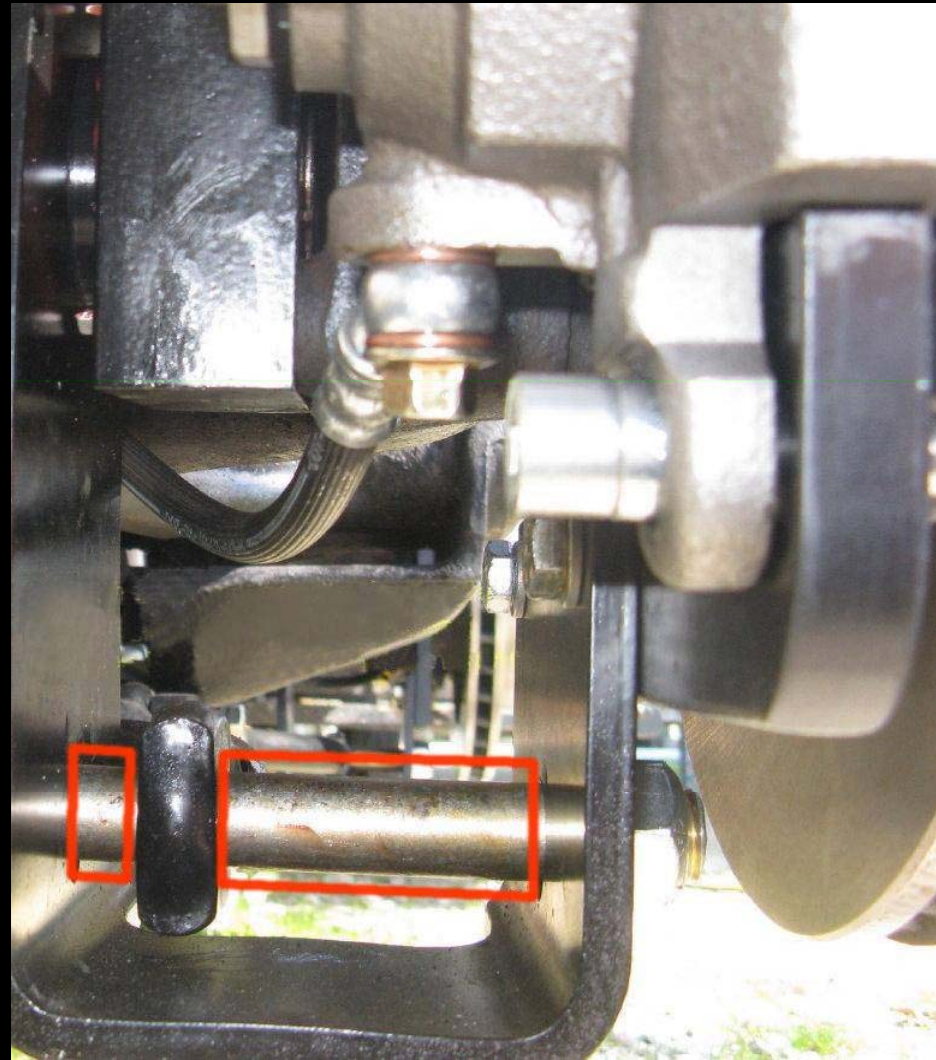

CHOOSING BRAKE CALIPERS FOR YOUR REACTION ARM BRAKE SYSTEM

- *FINALLY!* Time to start talking about choosing brake calipers for your new reaction rod system, whatever form it might take.
- In the next slide we'll see how the "pitch forward" component loaded up the front wheel force due to the "pole vaulting" effect when braking our GMC's.

CHOOSING BRAKE CALIPERS FOR YOUR REACTION ARM BRAKE SYSTEM

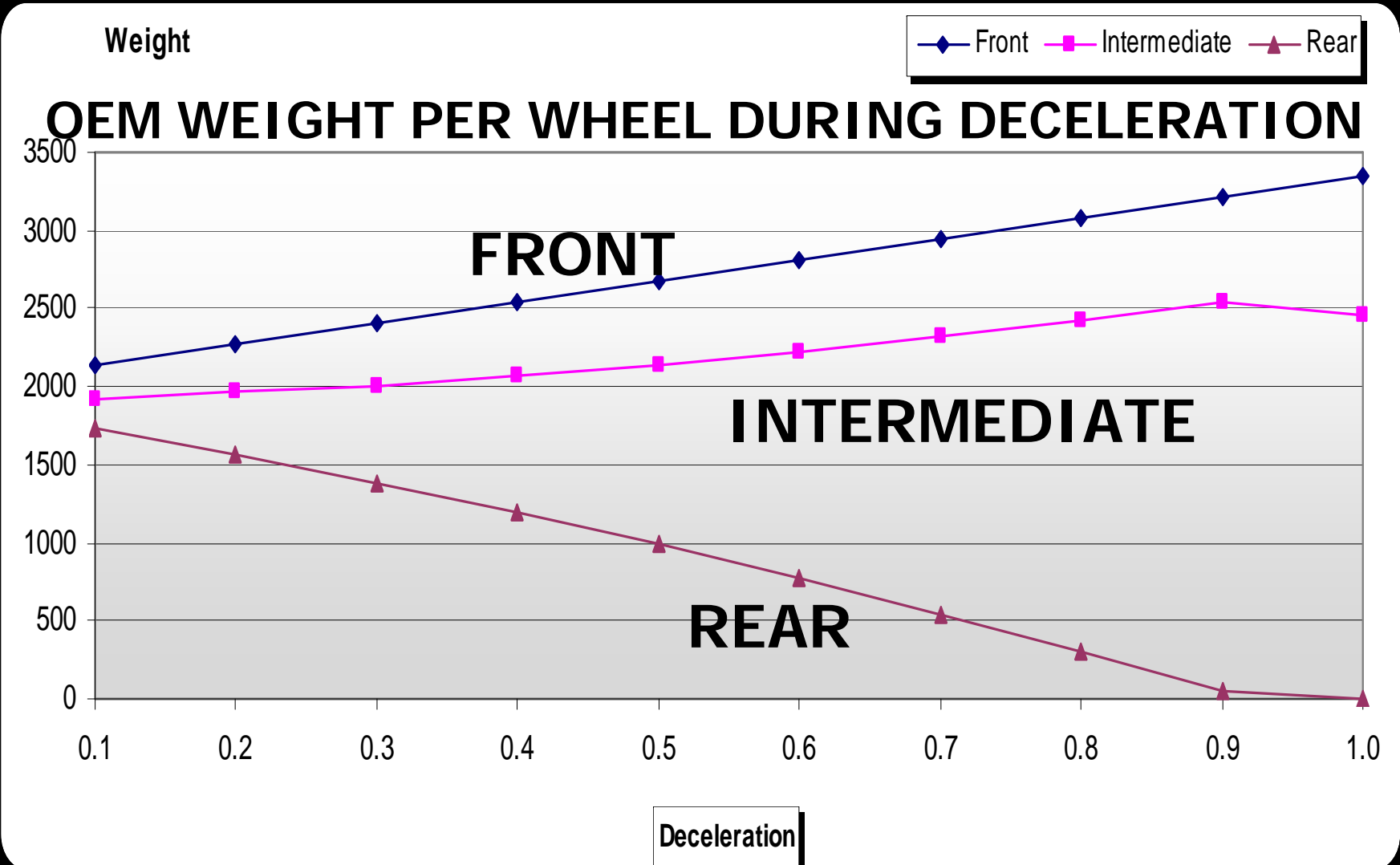

CHOOSING BRAKE CALIPERS FOR YOUR REACTION ARM BRAKE SYSTEM

- The graph below illustrates the effect of the reaction arm brake system on the "pitch forward" component when aggressively braking the GMC, pay particular attention to the 0.75 G area, the pitch forward component has been reduced from approx. 50 % down to less than 10% .

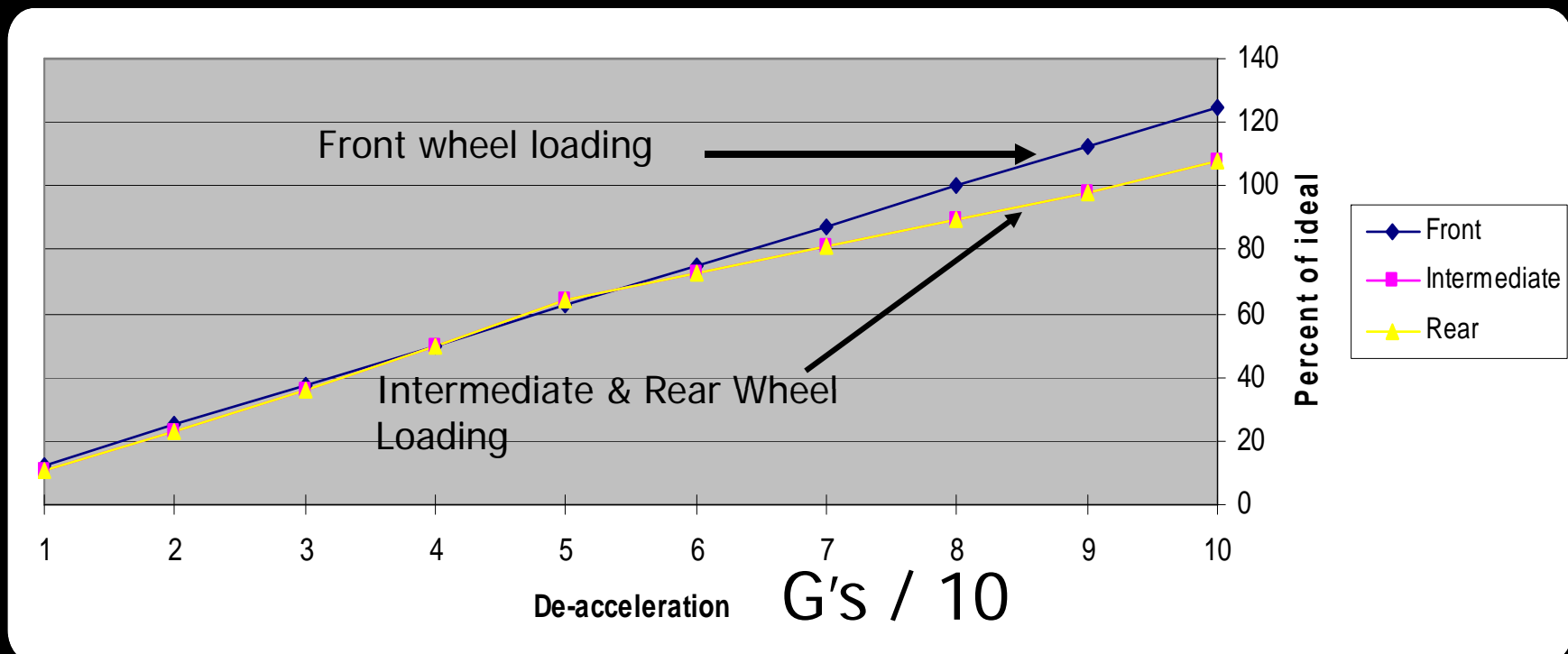

CHOOSING BRAKE CALIPERS FOR YOUR REACTION ARM BRAKE SYSTEM

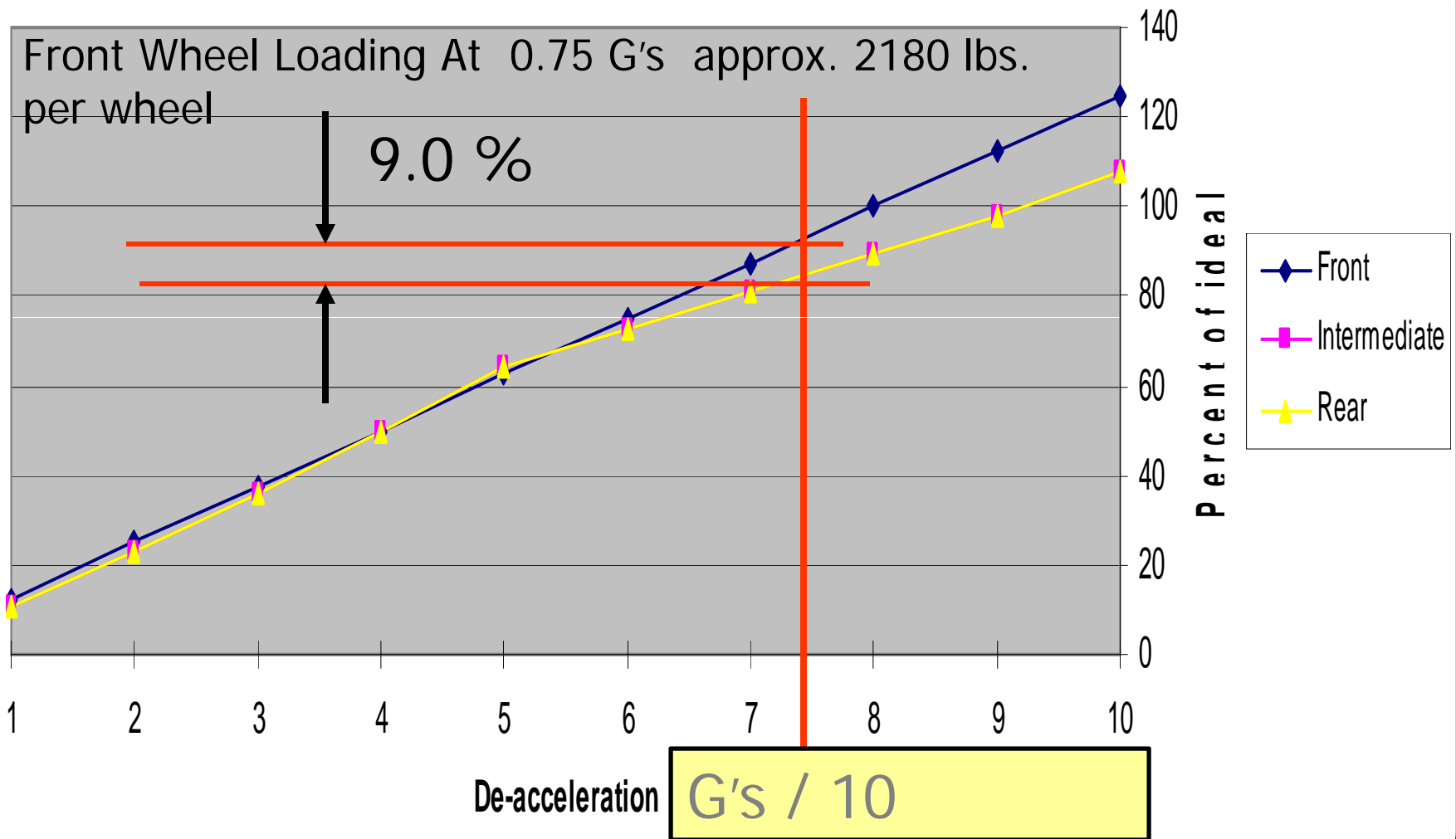

CHOOSING BRAKE CALIPERS FOR YOUR REACTION ARM BRAKE SYSTEM

- Pitch to front at lockup is just over 1% per 0.1G of de-acceleration, for example our GMC motorhomes will experience imminent lockup of one or more tires at approx. 0.75G's . This equates to a 9.0% mass increase on the two front tires. Therefore : 4000 Lbs. X 1.09 = 4360 Lbs. with reaction rods instead of the usual 6000 Lbs.

CHOOSING BRAKE CALIPERS FOR YOUR REACTION ARM BRAKE SYSTEM

- Going back to our GMC outline:

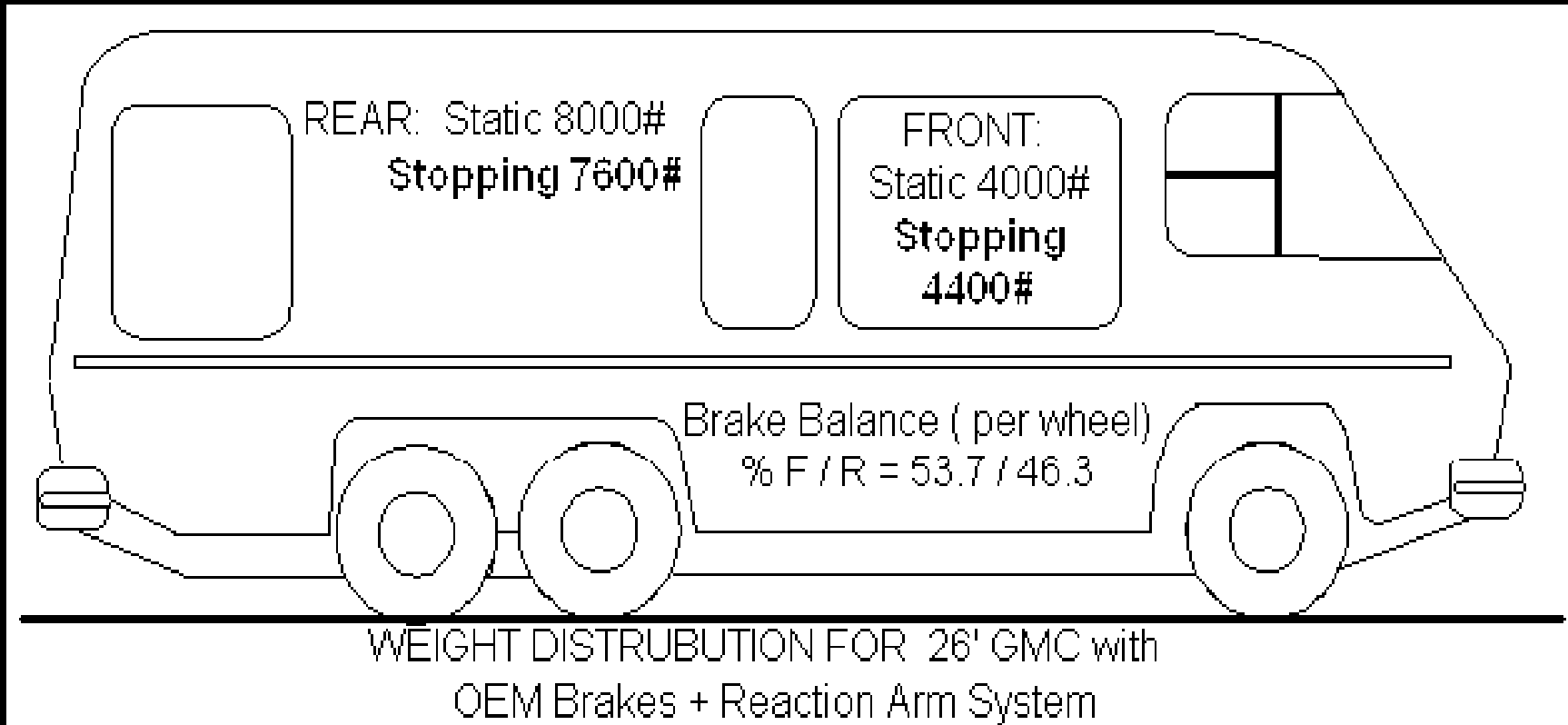

GMC fitted with reaction arm system, OEM brakes and at 0.75G deceleration , brake balance per wheel is good !

CHOOSING BRAKE CALIPERS FOR YOUR REACTION ARM BRAKE SYSTEM

- In summary ; in placing the reaction rod braking system on your coach, you will be assured that you will ALWAYS have a mass of at least 7,600 pounds for the 4 rear brake assemblies to accommodate as heat into drums, rotors , or a combo of both.

REMEMBER:

- Kinetic Energy = Weight X Speed Squared / 29.9 – ENTIRELY DUMPED INTO YOUR ROTORS OR DRUMS AS HEAT !

CHOOSING BRAKE CALIPERS FOR YOUR REACTION ARM BRAKE SYSTEM

- One must assume that the reason you bought the "reaction arm system" in the first place ; was to enhance the rear braking capabilities of your coach ?
- One would also safely assume that you would want calipers sized to optimize the rear braking forces to address the load that 7,600 plus pounds is going to demand of your braking system ?

CHOOSING BRAKE CALIPERS FOR YOUR REACTION ARM BRAKE SYSTEM

- The addition of reaction arms to the coach will for the first time allow you to fully utilize the braking capabilities of the rear most wheel set without the risk of "flat spotting" the tires.
- For example , the OEM (70mm) front caliper , the K-H 2.6" park brake caliper or the 2.5" Delco-Moraine park brake caliper could be used .

CHOOSING BRAKE CALIPERS FOR YOUR REACTION ARM BRAKE SYSTEM

- With the installation of the “reaction arm system” ; you have in effect reduced the braking demands placed of the front wheels by upwards of 35 % , i.e.. From about 3,000 lbs. (approaching lock-up !) down to approx. 2,200 lbs. per wheel. i.e.. From an overload of 50% (1,000 Lbs.) down to an approx. overload of 10 % (200 Lbs.) per wheel .
- BUT ! At the same time you added a one ton front end AND consequently increased your front braking force. ***Reduced the load and increased the braking force ! (GOOD !)***

CHOOSING BRAKE CALIPERS FOR YOUR REACTION ARM BRAKE SYSTEM

However on the rear of the coach , with an established dynamic weight of at least 7,600 Lbs. , we are proposing a set of brakes designed for a mid- sized car , weighing between 3,500 and 4,000 lbs.

i.e.. Increase the load and reduce the braking force ! Just don't seem like the thing one would want to do ? Seeing it's the direct opposite of what was done on the front of the coach !

CHOOSING BRAKE CALIPERS FOR YOUR REACTION ARM BRAKE SYSTEM

Frank Cannon & His Mark Series Lincoln

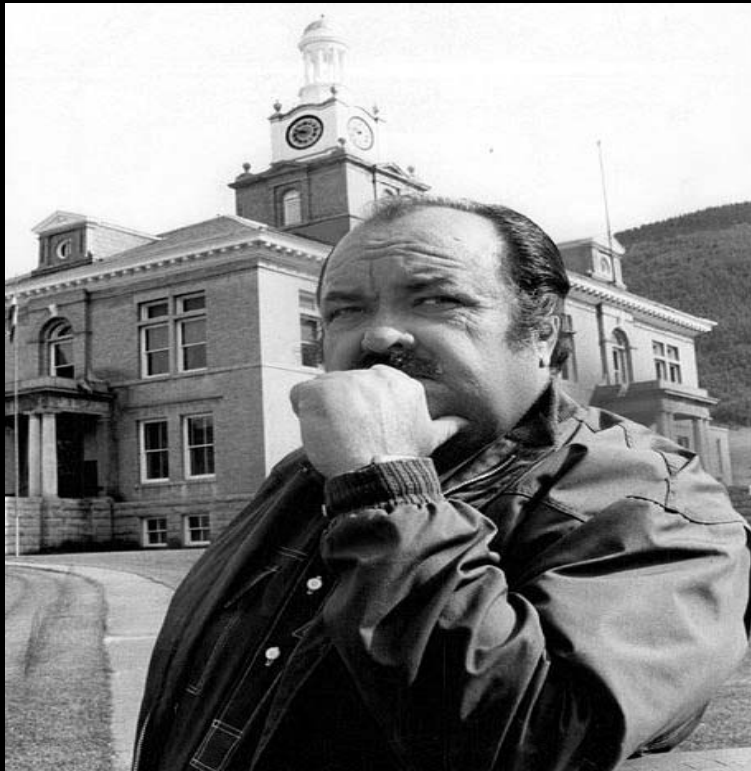

27/10/2013

CHOOSING BRAKE CALIPERS FOR YOUR REACTION ARM BRAKE SYSTEM

- The Mark series Lincolns manufactured up to 1979 had a massive braking system. The cars weighed about 5000 Lbs. plus or minus 10% depending upon options or if Frank was sitting in the drivers seat.

Details of the brake system:

- 3.11" front calipers with 11.8" rotors.
- 2.6" K-H rear park brake calipers with 11.5" rotors.
- Hydro boost ! With an output of 1100 psi.

CHOOSING BRAKE CALIPERS FOR YOUR REACTION ARM BRAKE SYSTEM

The next slide shows a comparison graph depicting the relative STATIC brake forces of the following :

- OEM GMC , 74.6mm discs + 4 -11" drums
- Our 23 foot Birchaven, all 11" discs, 2 sets 80mm calipers , 2.6" K-H PB caliper & OEM master cylinder.
- Manny's coach fitted with his reaction arms and his 12.5" rotors on the one ton front end and P-30 type master cylinder.

CHOOSING BRAKE CALIPERS FOR YOUR REACTION ARM BRAKE SYSTEM

- A theoretical coach with one ton front end, Harrison 12.5" intermediate discs and Caddy 63.5mm park brake calipers on the rear most wheel set and a P-30 master cylinder. (MAX)
- A (STRETCH) coach from the mid-west with OEM front brakes with an 80mm caliper, Manny reaction rod system and a P-30 master cylinder.

CHOOSING BRAKE CALIPERS FOR YOUR REACTION ARM BRAKE SYSTEM

Y – AXIS : 0 to 12K Pounds, Overall Brake Force

LEGEND : RED= Front , BLUE= Rear , Yellow=Front +Rear

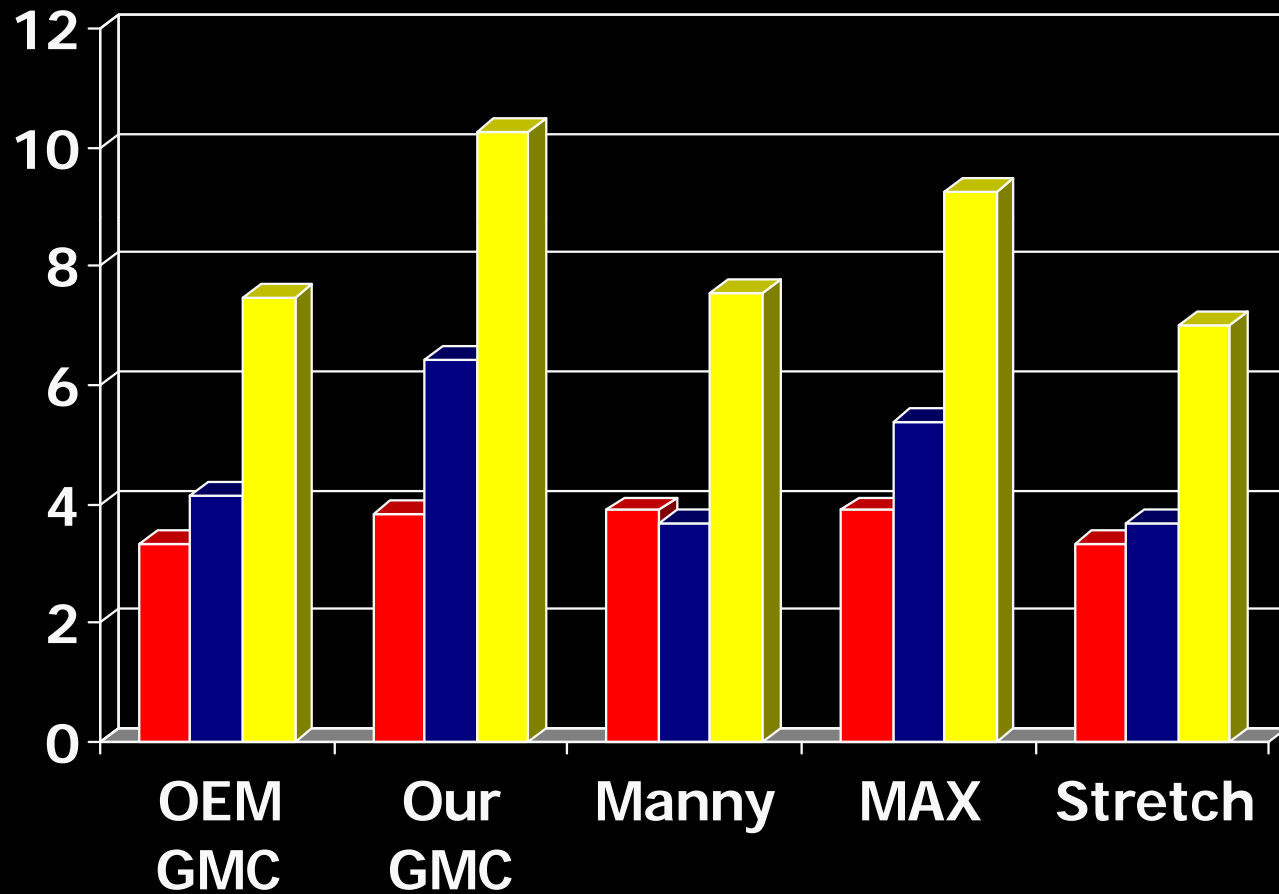

CHOOSING BRAKE CALIPERS FOR YOUR REACTION ARM BRAKE SYSTEM

Keep in mind , the preceding graph depicted (STATIC) braking forces only and is not meant to be a comparison of (Dynamic) braking forces.

With the addition of reaction arms to each of the coaches, then the static numbers become meaningful. It's nearly impossible to quantitatively compare the braking of one coach with reaction arms to another coach without the reaction arm system.

CHOOSING BRAKE CALIPERS FOR YOUR REACTION ARM BRAKE SYSTEM

- What does stand out somewhat on the graph is the difference the 3 different master cylinders (M/C) make , i.e.. The hydro boost M/C, the OEM 1-1/4" M/C and the P30 type – 34mm M/C .
- For example, **ALL** the gain achieved from the 12.5" Harrison discs and the 12.5" one ton front end discs is TOTALLY negated by the use of the P-30 , 34 mm M/C as compared to the 1- 1/4" OEM master cylinder.

CHOOSING BRAKE CALIPERS FOR YOUR REACTION ARM BRAKE SYSTEM

NOTE : Brake force calculation methodology:
Since a number of " constants " were used in the preceding calculations such as brake pad coeff. of friction , rotor " swept radius" , tire " rolling radius" , OEM 1-1/4" bore master cylinder pressure (825 psig) . The absolute numbers may vary slightly from your calculations.

HOWEVER ! The same "constants" were used for ALL calculations thus making the ratios valid.
DATA calc. sheets may be obtained by emailing me at : branscoa@bmts.com

CHOOSING BRAKE CALIPERS FOR YOUR REACTION ARM BRAKE SYSTEM

Briefly, before getting to select brake calipers for our new reaction arm system ; Let's have a look at the two major items preceding the calipers and rotors, namely , the master cylinder and the caliper backing plates.

CHOOSING BRAKE CALIPERS FOR YOUR REACTION ARM BRAKE SYSTEM

Master Cylinder Pressure Available

NEVER
EXISTED !

M / C Piston Dia.	1 - 1/8"	1 - 1/4"	1 - 5/16"	34 mm Dia.	40 mm Dia.	40 mm HB
	1.125" Dia.	1.250" Dia.	1.313" Dia.	34 mm Dia.	40 mm Dia.	40 mm HB
M / C Pressure Out	1000 PSI	815 PSI	725 PSI	710 PSI	513 PSI	1027 PSI
Percent loss in output pressure compared to 1-1/8" M/C Piston	0.0 % LOSS	18.5 % LOSS	27.5 % LOSS	29.0 % LOSS	48.7 % LOSS	2.7 % GAIN

CHOOSING BRAKE CALIPERS FOR YOUR REACTION ARM BRAKE SYSTEM

Although only 11 % difference in output pressures given a fixed input . Master cylinders ARE the heart of your braking system !

*OEM – 1-1/4" M/C
Casting # 29895-C*

*P30 Type – 34mm M/C
39309 or equivalent*



CHOOSING BRAKE CALIPERS FOR YOUR REACTION ARM BRAKE SYSTEM

In the next slide is a comparison of the effect of the two previous master cylinders (M/C) in "Static Mode" on a GMC Motorhome .

- OEM GMC : 11" front rotor & 4 -11" drums and an OEM 1 – ¼" master cylinder.
- OUR COACH : All 11.0" rotors, 2 sets of 80mm calipers & 1 set of 66 mm calipers and an OEM M/C @ 1-1/4"

CHOOSING BRAKE CALIPERS FOR YOUR REACTION ARM BRAKE SYSTEM

- **MAXIMUM:** 12.5" rotors front & intermediate, 80mm calipers on each with 63.5 mm caliper on rear and P30 master cylinder
- Franks, Mark series Lincoln with 11.8" front rotors & 3.11" calipers AND 11.5" rear rotors & 2.6" PB calipers plus 1100 psi hydro boost !

CHOOSING BRAKE CALIPERS FOR YOUR REACTION ARM BRAKE SYSTEM

Y – AXIS : 0 to 12K Pounds, Overall Brake Force

LEGEND : RED= Front , BLUE= Rear , Yellow=Front +Rear

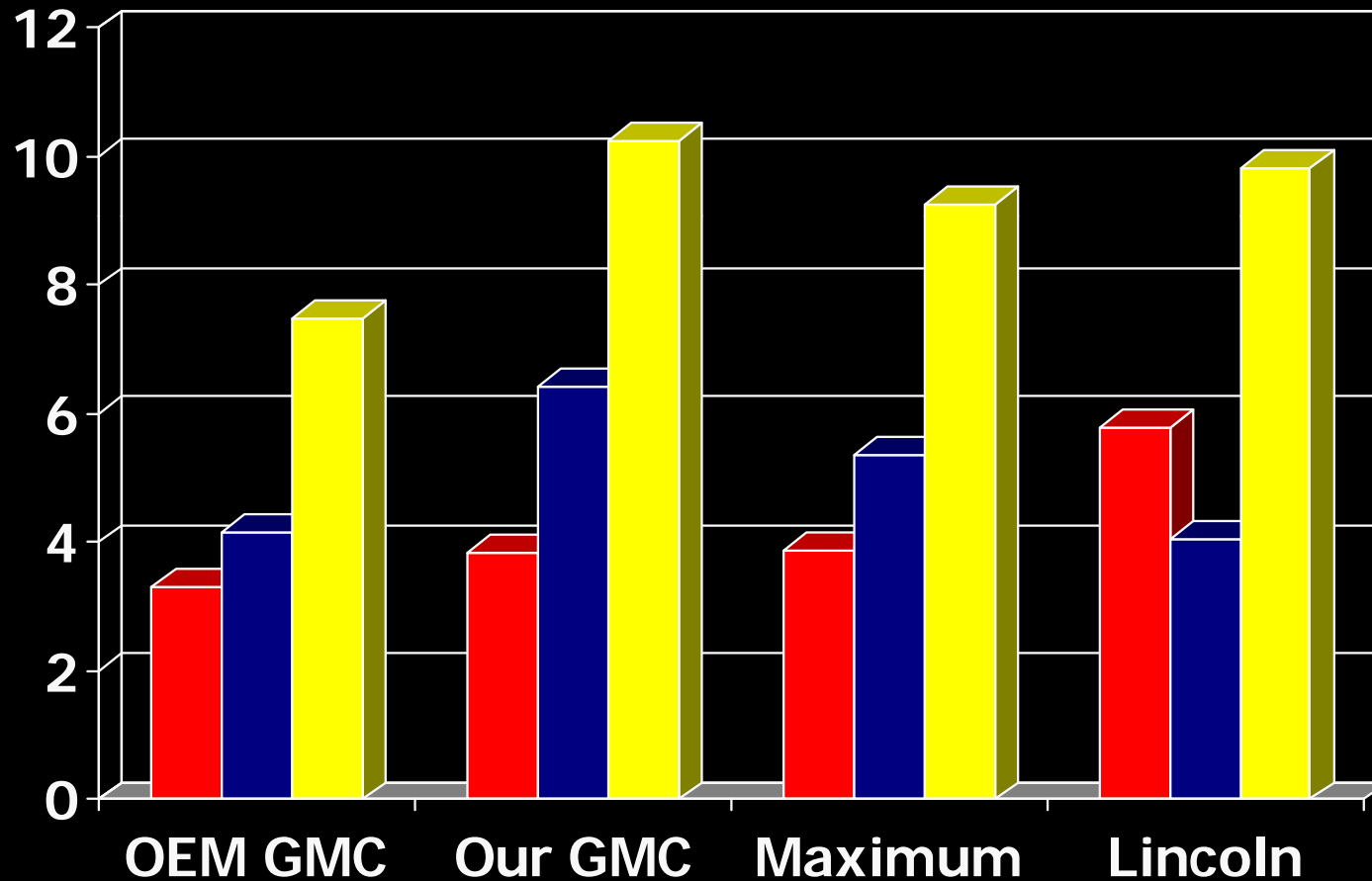

Disc Brake Master Cylinder Requirements:

- **Requirement #1:** To convert the force of our foot on the brake pedal to hydraulic pressure via the piston(s) in the master cylinder (MC) to supply our calipers.
- **Requirement #2:** To contain enough fluid to enable one to completely wear out all friction material on the brake pads and still have some fluid in the MC reservoir(s). An SAE decree from the 1960's

Master Cylinder(MC) Requirement #1:

In our case of running 6 wheel discs with an OEM MC with 80mm, 80mm and 66mm calipers front to back respectively and still have an adequate brake pedal height, how is that possible ? The deciding factor is a phenomenon known as caliper "piston knock back".

Let's review the common causes of excessive brake pedal movement and reserve "piston knock back" for last.

Disc Brake Master Cylinder Requirements: regarding common causes of " low" pedal

- Friction material clearances
- Design clearances and wear in linkages
- Swelling of hydraulic hoses
- Slight compression of hydraulic fluid
- Compression of air bubbles in hyd. fluid
- Bending of pedal, linkage or brackets
- Deflection of calipers, drums, backing plates or caliper mounts

Caliper "piston knockback" causes

- Caliper "piston knock back" issues are greater than all the previous mentioned " low pedal" factors put together. There are a number of reasons for piston knock back:
 - Brake rotor lateral " run out"
 - Wheel bearing slackness, misadjusted bearings
 - Normal piston retraction via square piston seal
 - Caliper " Bridge" deflection
 - Sticking of caliper on its rails or slide pins.
 - Bent wheel spindles

Caliper “piston knockback” Issues

The largest factor of all contributing to caliper piston knock back and accompanying low brake pedal and needing larger master cylinder pistons is brake caliper mounting plate flex. Two factors are prevalent here:

- #1/ The caliper itself cocking in its mount.
- #2/ The caliper mount flexing relative to its attachment point on the spindle.

Caliper Piston Knockback Issues

Observe the bearing surface where the caliper impacts on its mount upon brake application. i.e.. 3/8" and approx. 2" out from the C/L of the brake rotor.

As the brake is applied the first thing that happens is the caliper cocks in its mount and secondly the whole mount begins to flex.

This setup MIGHT be OK for an automobile with 500 to 800 pounds per wheel but is woefully inadequate for combating undue flex / cocking at 2000 pounds per wheel on a GMC Motorhome.

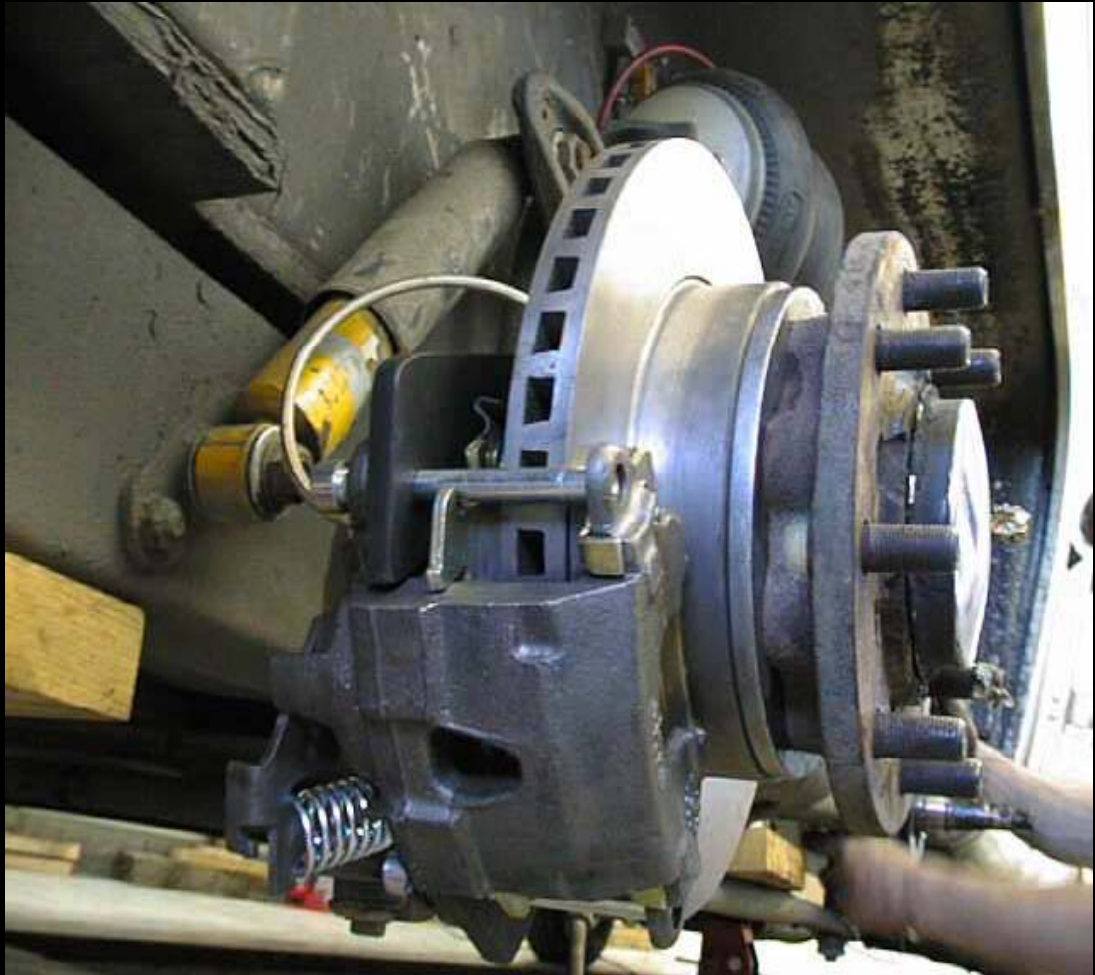

CHOOSING BRAKE CALIPERS FOR YOUR REACTION ARM BRAKE SYSTEM

- There are those folk that will say that their calipers / backing plates don't flex and that they never had problems with either, They had problems or they would not have had to change master cylinders.
- Emery got me interested in the quantitative aspect of backing plate flex by relating a story to me of an incident he encountered in Florida many years ago.

CHOOSING BRAKE CALIPERS FOR YOUR REACTION ARM BRAKE SYSTEM

Everyone seemed to have one sort of opinion or another , so actually measuring caliper / backing plate assembly flex seemed to be the only solution.

The silver colored cylinder at the bottom of the photo is a 2.0" stroke, 2000 ohm precision linear pot. , i.e.. Resolution of 0.001" (even has a nuclear clover leaf stamp)

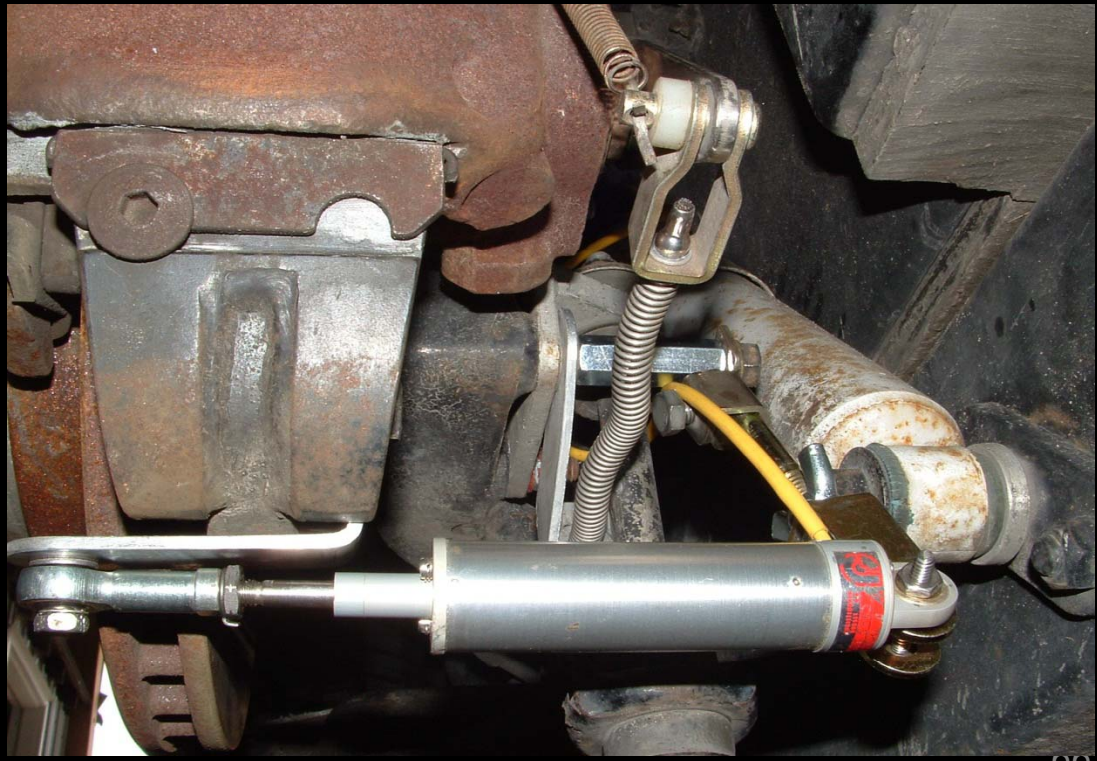

27/10/2013

00

CHOOSING BRAKE CALIPERS FOR YOUR REACTION ARM BRAKE SYSTEM

- And recorded it as well !



CHOOSING BRAKE CALIPERS FOR YOUR REACTION ARM BRAKE SYSTEM

- Close up of chart recorder : $\pm 0.050''$

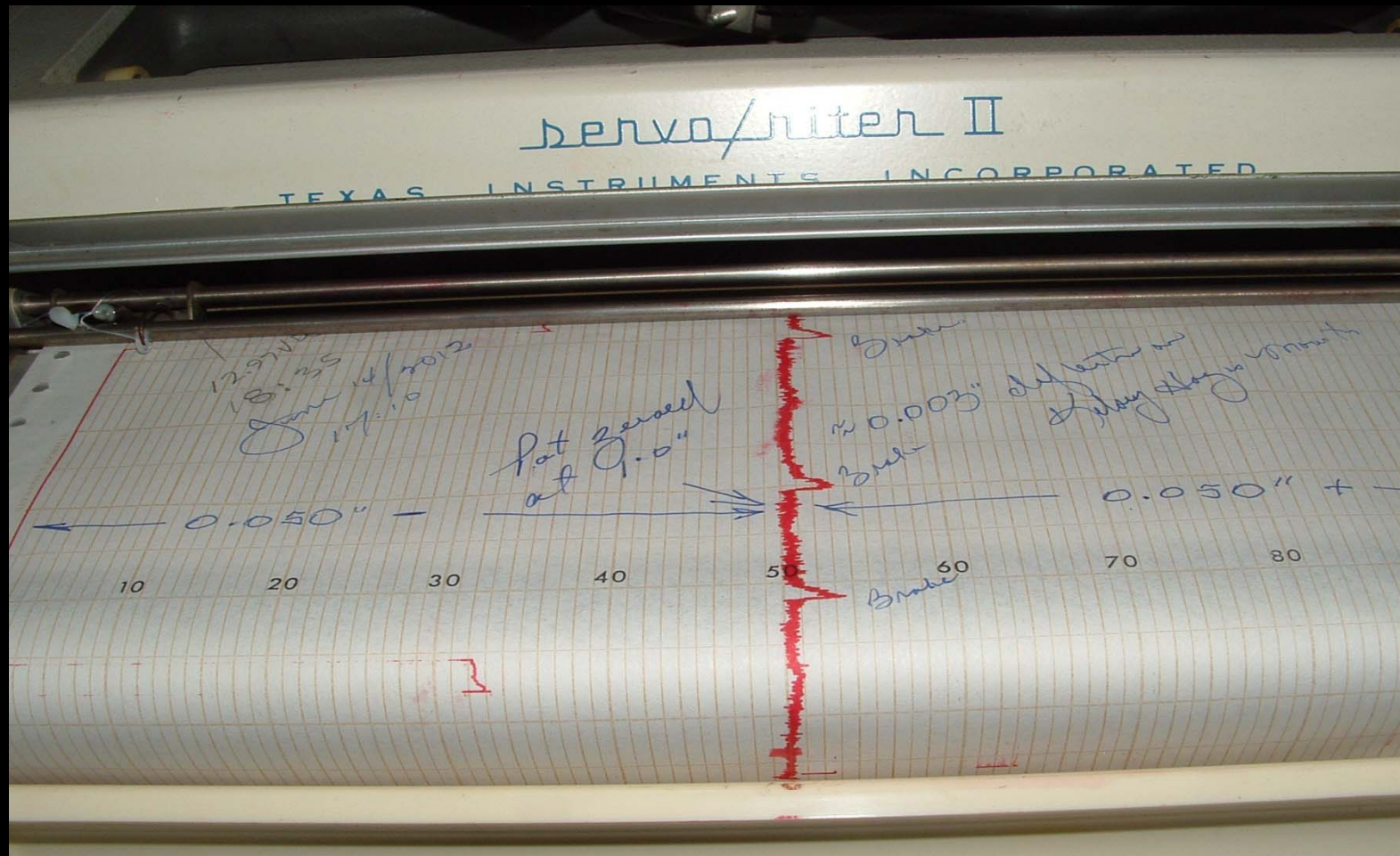

Caliper "piston knockback" Issues

Caliper Mounting—It is essential that a caliper not move or flex as the brakes are applied—other than the lateral movement of a floating caliper. If the caliper-mounting structure is flexible, the caliper can twist on its mount. This causes uneven pad wear, a spongy pedal and excessive pedal movement.

A common race-car design error is using thin, flexible brackets to mount the caliper to the spindle. Because the

rotor and caliper-mounting bracket lie in two different planes, the caliper bracket has a twisting force on it when the brakes are applied. If the bracket is too thin, it will twist, cocking the caliper against the rotor. Generally, a mounting bracket at least 1/2-in. thick should be used, particularly on large race cars such as stock cars.

Caliper "piston knockback" Issues

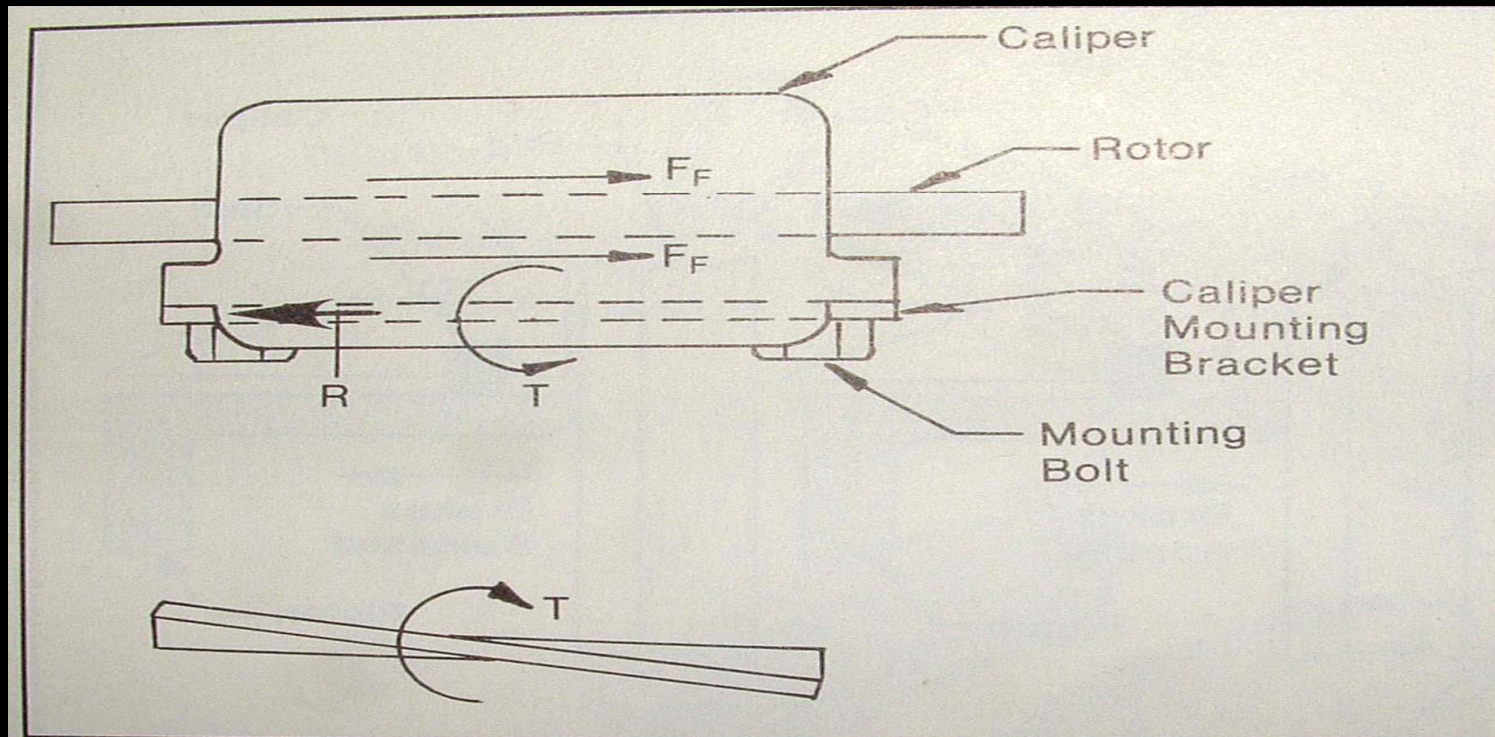

Forces on brake pads, indicated by F_F , are resisted by a force R at caliper bracket. Because force R is not in line with the rotor, twisting torque T is also applied to the bracket. Effect of twisting torque on the bracket is shown in lower drawing. If mounting bracket is not sufficiently rigid, caliper cocks against rotor, causing uneven pad wear, spongy pedal, and excessive pedal movement. Use a stiff caliper bracket and this will not happen.

Caliper "piston knockback" Issues

Fred Puhn is a mechanical Eng. And spent a lifetime designing and researching brake systems for mainly racing applications but also for the North American domestic market as well.

This book is currently out of print but is readily available as a download from the internet as is a second book that he had published in the mid. '80,s.

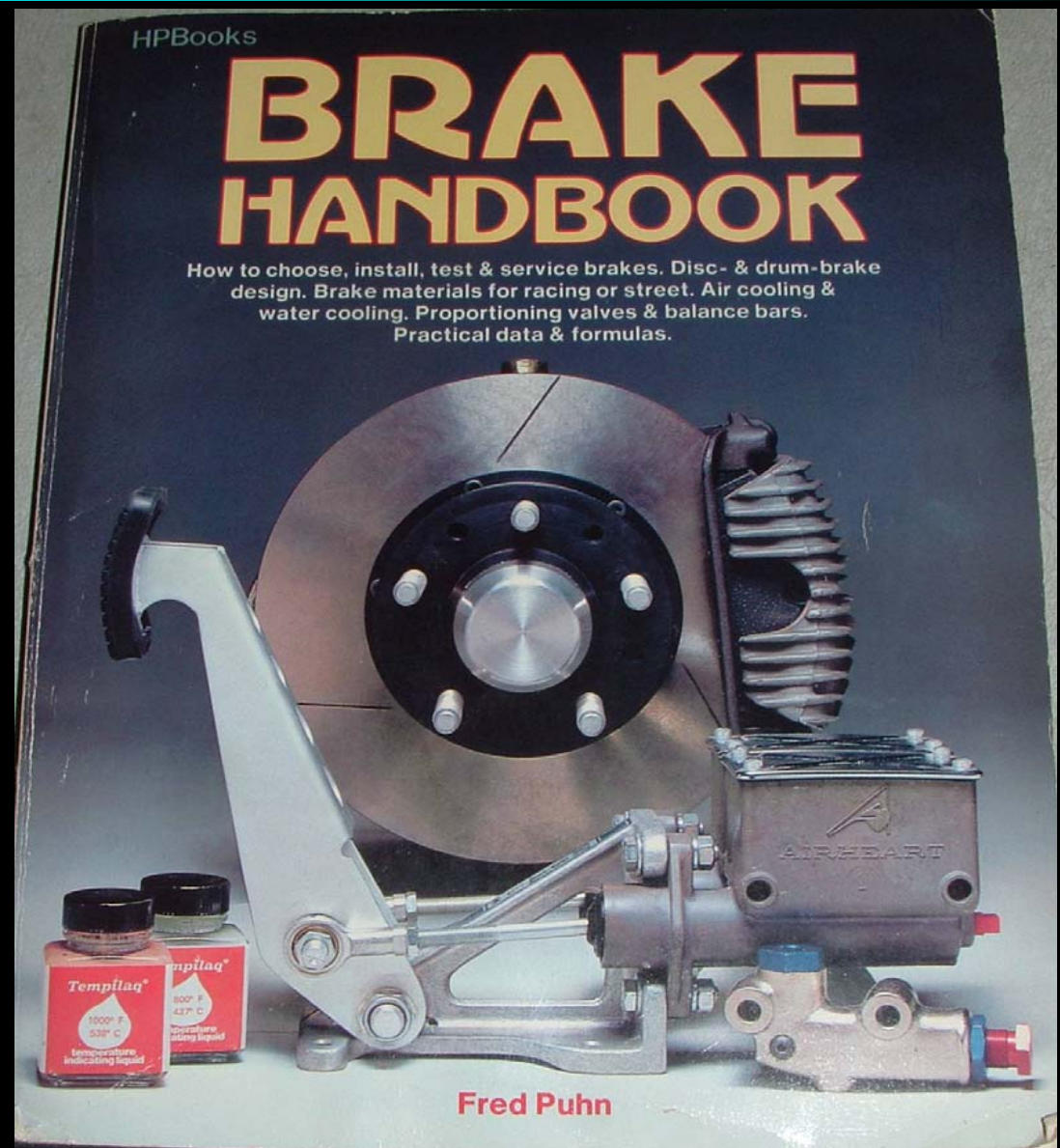

CHOOSING BRAKE CALIPERS FOR YOUR REACTION ARM BRAKE SYSTEM

Going back to the late 90's when folks first started experimenting with the second and third set of disc brakes on their GMC, they were plagued with excessive brake pedal travel and simply attributed it to having the larger displacement brake calipers and searched around until a master cylinder could be found that had sufficient displacement to solve their problems as in the P30 family of 34 mm M/C's.

CHOOSING BRAKE CALIPERS FOR YOUR REACTION ARM BRAKE SYSTEM

- The new P30 master cylinder (M/C) solved the low brake pedal problem but at the expense of losing 11% output pressure when referenced to the OEM M/C .
- An added benefit of the P-30 M/C was that it also solve the problem of reservoir capacity , i.e.. Having enough fluid capacity to run your pads to the metal without emptying the M/C.

CHOOSING BRAKE CALIPERS FOR YOUR REACTION ARM BRAKE SYSTEM

However with that said; the P-30 M/C is not without its faults:

- You lose 11% of your braking force due to the larger bore pistons.
- It uses poppet type check valves which sometimes fail by becoming dislodged from their seats.
- It uses O-rings instead of "cup seals" thus making brake pedal return slow due to the much higher friction characteristics of the O-rings verses the "cup seals" .

CHOOSING BRAKE CALIPERS FOR YOUR REACTION ARM BRAKE SYSTEM

Pegasus Auto Racing sells an excellent 10 oz. remote reservoir (#3565) that will be sufficient for our use.

HOWEVER ! The special 5/16" dia . hose they sell for the reservoir **MUST** be used. Very few hose materials are impervious to brake fluid.



1- 1/4" bore OEM master cylinder with a 12 oz. remote reservoir connected to the front chamber , ie. the chamber that supplies the rear brakes.

CHOOSING BRAKE CALIPERS FOR YOUR REACTION ARM BRAKE SYSTEM

The OEM 1 – ¼" dia. master cylinder cannot **"SAFELY"** be used in conjunction with the following backing plates due to excessive flexing and " piston knock back" issues.

- Any of the TSM type backing plates.
- The Harrison 12.5" setback backing plate.
- The OEM Caddy backing plate.

CHOOSING BRAKE CALIPERS FOR YOUR REACTION ARM BRAKE SYSTEM

TSM type backing plate, typically 5/16" to 3/8" thick mild steel plate.

NOT ! Hub centered

Possibly Ok for an automobile , but not for a vehicle weighing upwards of 2 to 3 times as much !



CHOOSING BRAKE CALIPERS FOR YOUR REACTION ARM BRAKE SYSTEM

Even worse than the standard TSM flat plate, is the TSM "stepped plate" used to avoid having to use a "rotor spacer."

Keep in mind; the further the rotor center line is from the spindle mounting plane, the greater the flex experienced by the backing plate !



CHOOSING BRAKE CALIPERS FOR YOUR REACTION ARM BRAKE SYSTEM

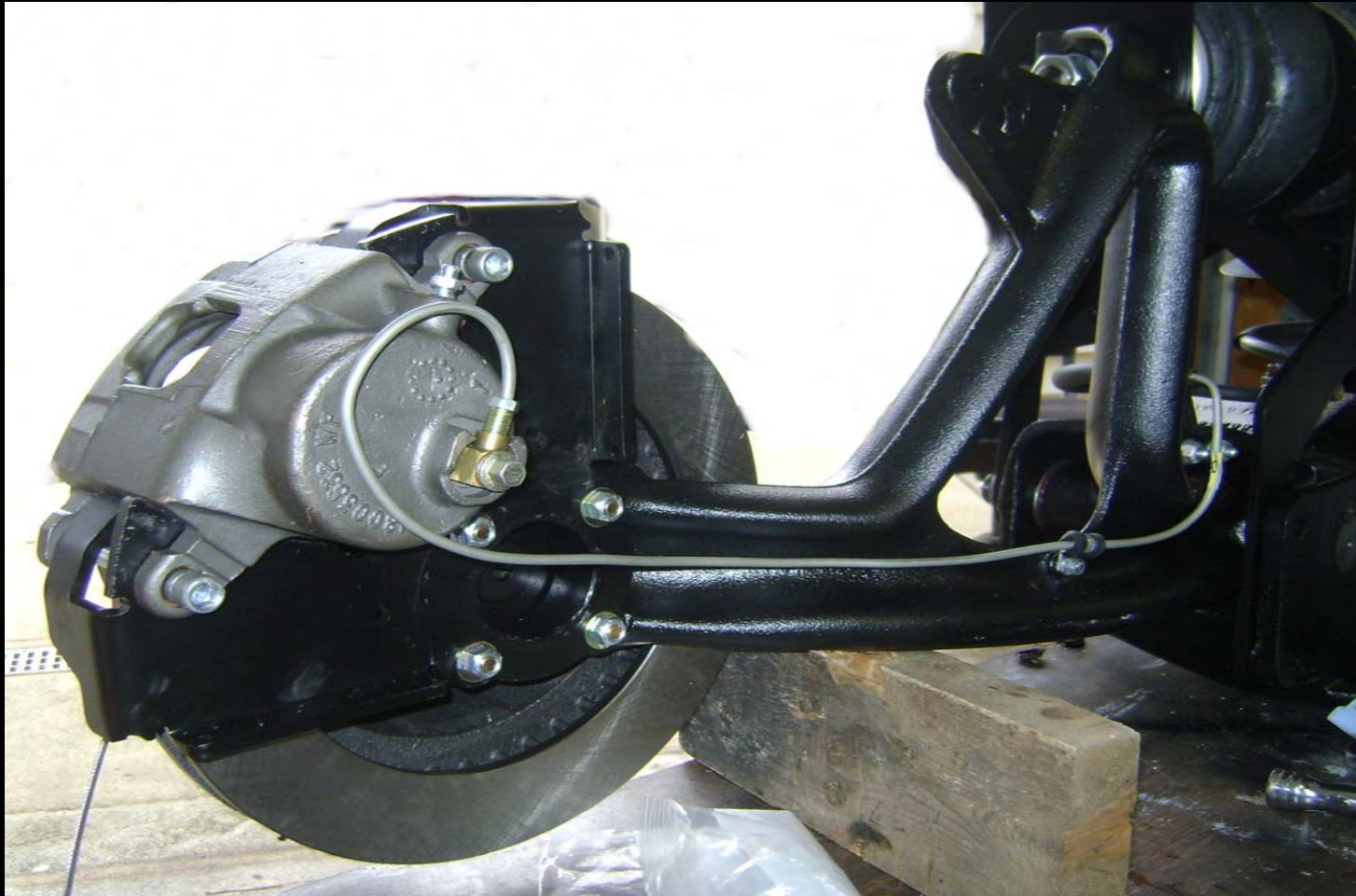

Harrison backing plate, 12.5" rotor , 1/4" steel plate,
a great deal of brake torque flex involved !

CHOOSING BRAKE CALIPERS FOR YOUR REACTION ARM BRAKE SYSTEM

This is the Caddy Backing plate used in the late '70s , Cadillac and Delco-Moraine had flexing problems with this plate from the word "Go" on the large Caddys, Olds & Buicks (more on the dispute later) .
AND: What do we see here ! On a somewhat heavier Vehicle – A GMC



CHOOSING BRAKE CALIPERS FOR YOUR REACTION ARM BRAKE SYSTEM

The intermediate or mid wheel set should have at least the OEM – 74.6mm calipers that was used on the front or preferably a set of 80mm calipers in conjunction with suitably rigid backing plates and 3/16" poly armor or stainless hard lines to the calipers bracket terminated with 12" braided stainless flex lines to the caliper itself. This applies whether you have reaction arms or not.

CHOOSING BRAKE CALIPERS FOR YOUR REACTION ARM BRAKE SYSTEM



OEM - 74.6mm caliper on intermediate wheel set , showing 3/16" hard line transition to a 12" braided stainless flex hose.

CHOOSING BRAKE CALIPERS FOR YOUR REACTION ARM BRAKE SYSTEM

ALAS ! A suitably rigid caliper mounting plate, it too will flex " BUT NOT VERY MUCH ! "

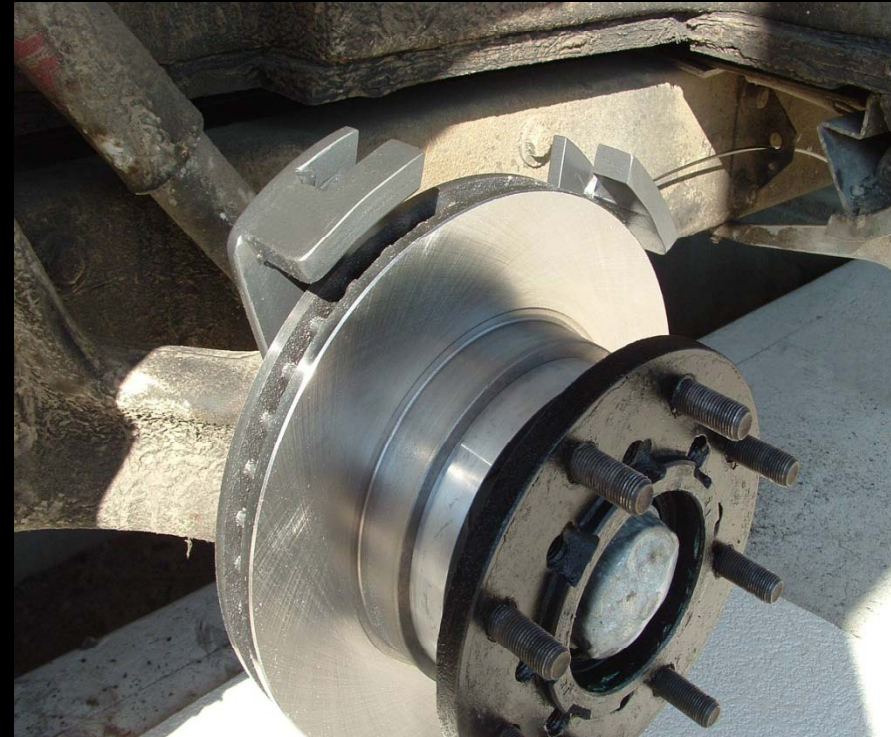

Lambke type caliper backing plate for 11" rotors & Toro and Caddy type calipers with 7.0" pin spacing..

CHOOSING BRAKE CALIPERS FOR YOUR REACTION ARM BRAKE SYSTEM

- **Calipers for the rear / rear wheel set of your GMC** . Not a lot of choice here , unfortunately , if you want a park brake caliper you are limited to the Caddy 2.1" or the 2.5" caliper or the 2.1" or 2.6" Kelsey Hayes park brake caliper.
- The Caddy parking brake caliper can be made to work if you religiously maintain it , I have a doc. by a chap by the name of "Lars Pederson" and he appears to have put "his all" into describing the rebuild procedure on said caliper . Google " Lars"Caddy caliper! Or email me and I'll send you the doc.

CHOOSING BRAKE CALIPERS FOR YOUR REACTION ARM BRAKE SYSTEM

- Cadillac motor division got into a shouting match with Delco Moraine (the caliper builder) in late 1977 regarding " low pedal" problems on autos equipped with the 63.5mm park brake caliper . Said caliper was not "auto adjusting" AND frequently the piston was becoming disengaged from its "D" indent and the keyway on the brake pad. Delco Moraine "caved" and started adding "balance springs" to the rear of the piston to ensure positive contact with the pad (fuel was cheap back then) . A service doc. was issued to the dealers in early 1978 describing the problems. The link to it is thus:

<http://www.modifiedcadillac.org/documents/1970s/1978/1978%20Brougham%20Seville%204%20wheel%20disc%20diagnostics/>

CHOOSING BRAKE CALIPERS FOR YOUR REACTION ARM BRAKE SYSTEM

The low pedal problem was eventually traced to two problems, #1/ The "auto adjuster" was not "auto adjusting" AND #2/ due to excessive flex in the caliper mount , the piston was being pushed back . i.e.. The same caliper mount shown a few slides ago on a GMC ! This " backing plate flex " and " failure to auto adjust" plagued GM right up to 1984 when the federal government ordered a recall on the 1984 Cameros at which time GM permanently dropped the caliper from use.

CHOOSING BRAKE CALIPERS FOR YOUR REACTION ARM BRAKE SYSTEM

- As can be seen, the family of Delco-Moraine park brake calipers (the 63.5mm, the 54mm and the 48mm) all had the same internals. It's not old age that led to the demise of the Delco Moraine calipers, essentially they were "junk" right off the drawing board. Apparently GM was too proud to buy them from Bendix / Kelsey Hayes unlike Chrysler, Ford and American Motors.

CHOOSING BRAKE CALIPERS FOR YOUR REACTION ARM BRAKE SYSTEM

The Kelsey Hayes "ball ramp" park brake calipers are still being produced by the millions (by TRW) , they are being used on BMW's, Audi's, Volvo's , Subaru's, etc. Unfortunately they max out at 45mm piston bore.

The 66mm Kelsey Hayes calipers are the largest park brake caliper ever made and the most reliable . Too bad there's only a handful left.

CHOOSING BRAKE CALIPERS FOR YOUR REACTION ARM BRAKE SYSTEM

- As mentioned ; the choices of a good park brake are getting slim, The Kelsey Hayes units are getting scarce , the Delco Moraine are as best a "crap shoot" and there are of course , the two choices below:



CHOOSING BRAKE CALIPERS FOR YOUR REACTION ARM BRAKE SYSTEM

How about a nice sturdy, reliable drum parking brake, coupled with an intermediate disc brake, reaction arms, OEM master cylinder and air assist on the PB handle ! Would sound like a winner all round .

I ran a drum park brake for years and found it to be very effective if kept maintained. I did have air boost and the brake was effective enough that one could NOT drive away with it engaged. There is nothing wrong with "drum" Brakes for a parking brake !

Disc Brakes

Internal components of Eldorado 2.5" dia. ; (Large) park brake



Internal components of Eldorado park brake caliper

HOW ABOUT A GMC PARKING
AND EMERGENCY BRAKE ?

Disc Brakes

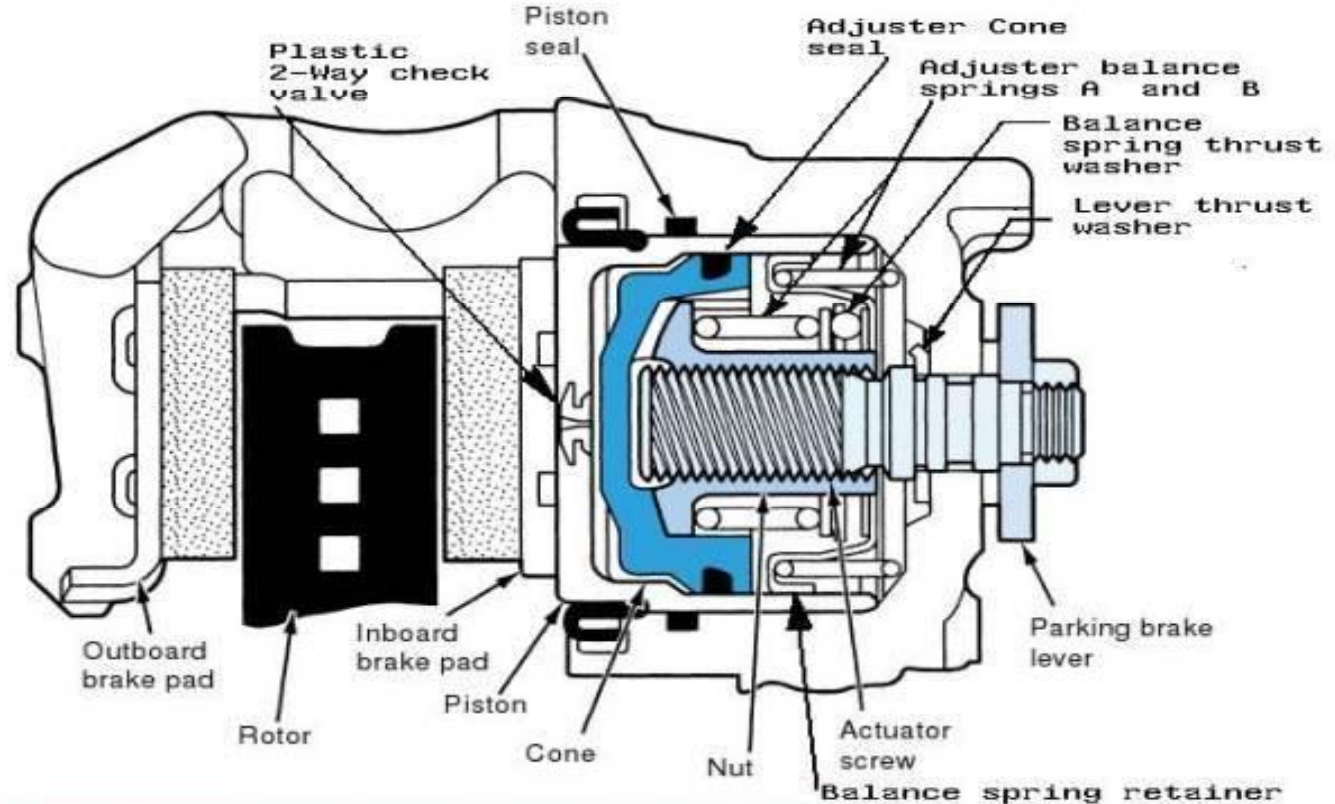

Figure 8-16 A GM screw-and-nut parking brake mechanism
(General Motors Corporation, Service Operations)

NOTE: Service and park brake adjuster function are both dependent upon regular use of the park brake. The automatic adjuster only functions when the park brake lever is routinely rotated and a 0.030" gap is present between the brake pad and rotor.

Pictorial of internal components of Eldorado

Disc Brakes

Internal components of 2.6" HBA park brake caliper



HBA Park Brake caliper internal components

Disc Brakes

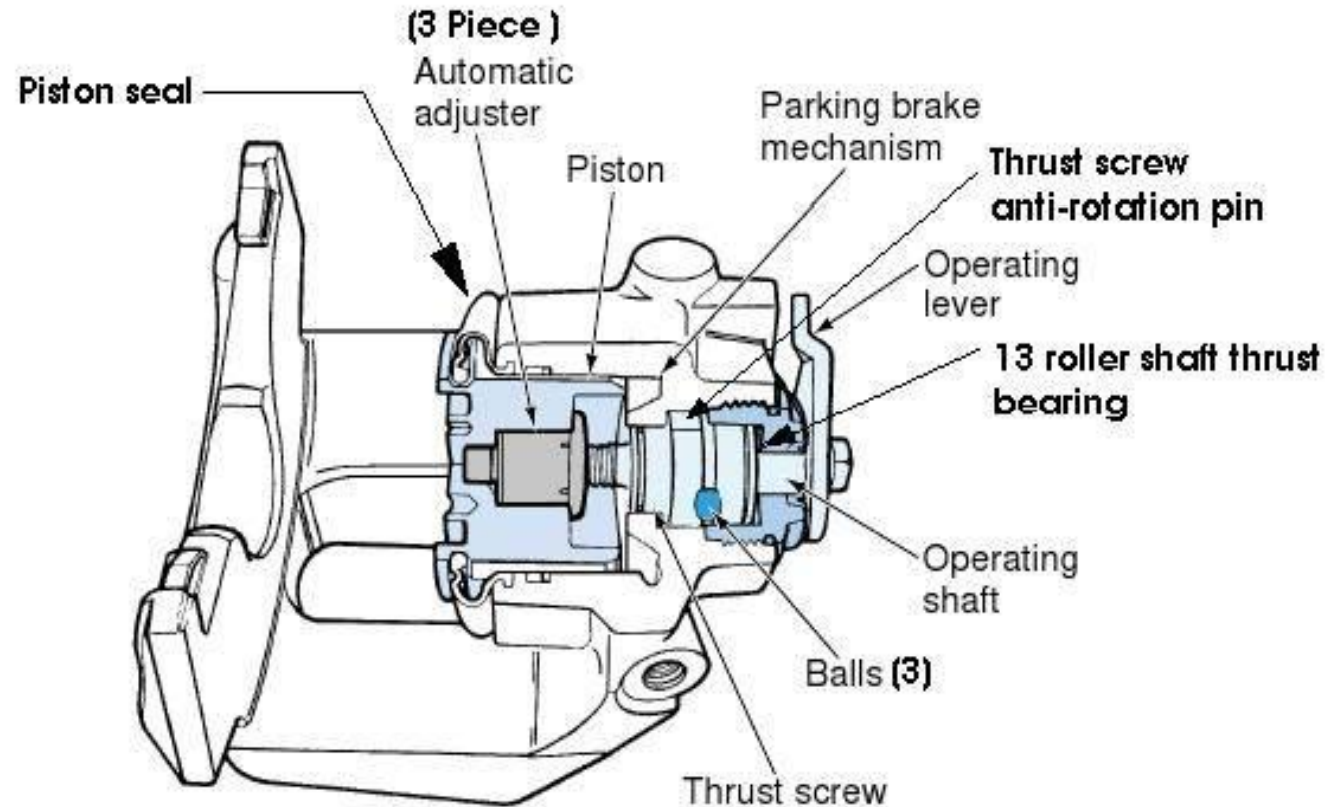

Kelsey - Hayes ball and ramp park brake caliper. Theoretical brake ratio 8 thru 30. Auto adjustment for pad wear via service brake at 0.020" gap. Park brake mechanism sealed from hydraulic chamber via thrust screw O-ring seal. Capable of over 10,000 Lb. clamp on brake rotor at 150 Lb. pull on park brake lever. (Hayes Brake Automotive Div.- HBA)

HOW ABOUT A GMC PARKING
AND EMERGENCY BRAKE ?

Summary of K-H & Eldorado Outputs

- **Eldorado Caliper Output :**
- 6000 Lbs. Piston force (12,000 lbs. clamp)
- 1.2" pull distance on 3.2" lever
- 465 Lbs. pull on lever

- **Kelsey Hayes Caliper Output :**
- 6000 Lbs. Piston force (12,000 lbs. clamp)
- 1.6" pull distance on 3.2" lever
- 145 Lbs. pull on lever

Summary of K-H & Eldorado Outputs

- As can be seen , the Eldorado caliper requires just over 3 times the pull force on the lever as the Kelsey Hayes caliper for the same output force thus requiring some sort of power assist to enable a useful output. I was surprised to observe that it took approx. 70% of the output of the KH caliper to hold our 11,000 lb. Birchaven on a 13% slope

Summary of K-H & Eldorado Outputs

- As also can be seen; the KH caliper required approx. $\frac{1}{2}$ " longer pull distance per caliper than did the Eldorado and this requires some distance multiplication on the cable system. The OEM park brake handle cable travel is limited to $2 - \frac{3}{8}$ ". Jim K. has complained to me about "short stroke problems" It just occurred to me, he was talking about the park brake handle cable.

Example of cable force / distance multiplication

Approx. 300 % increase in force and distance on parking brake cables compared to OEM setup !



HOW ABOUT A GMC PARKING
AND EMERGENCY BRAKE ?

The Kelsey Hayes / Bendix PB Caliper

- I have harvested 13 of the KH calipers from various wrecking yards to see what damage they had suffered over a 30 + year period, 3 had mild lever shaft corrosion due to bad seals and 5 had piston damage for the same reason. In no case was the " ball-ramp" mechanism damaged nor was the adjuster mechanism damaged at all.

The Kelsey Hayes / Bendix PB Caliper

After beating the bushes for weeks, I found a supplier for the pistons and associated seal kits. John at Goldline Caliper rebuilders in Seattle WA has pistons and will rebuild the calipers.

The photo to the right shows 11 pistons that were manufactured about a month ago in a plant about 30 miles north of Toronto, CAN.

The KH caliper appears virtually "Bullet Proof" and any damage they do suffer can be addressed.



HOW ABOUT A GMC PARKING
AND EMERGENCY BRAKE ?

The Kelsey Hayes / Bendix PB Caliper

- Some of the features of the K-H caliper
- 2.6 " dia. Piston (66 mm)
- Hyd. Force @1K PSI = 5310 Lbs.
- Mechanical force @ 150 lb. pull = 6000 lbs.
- Auto Adjust via service brake application
- Variable rate " ball ramp" actuation with an MA of approx. 20 to 40
- "Ball ramp" chamber isolated from brake fluid chamber

HOW ABOUT A GMC PARKING
AND EMERGENCY BRAKE ?

The Kelsey Hayes / Bendix PB Caliper

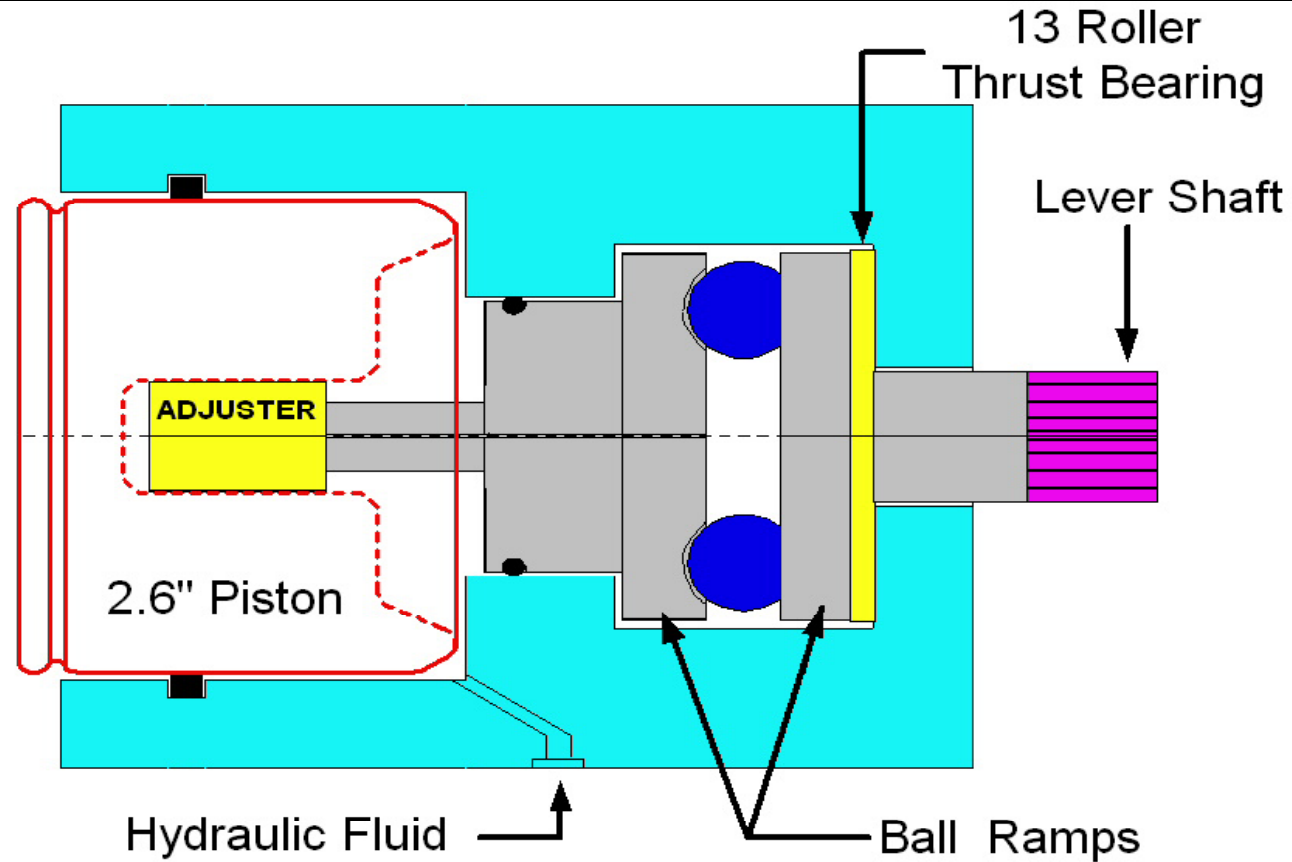

KELSEY HAYES / BENDIX PARK BRAKE CALIPER INTERNALS

The Kelsey Hayes / Bendix PB Caliper

- When Kelsey Hayes was split up into a number of companies in the '80's , the new companies all maintained the original " ball-ramp" patents and applied them to new generations of brake calipers, some of the companies are: TRW, Bendix, Hayes Performance Systems , AM General (H1 / A1 Hummer) to name a few.

For Questions or Purchase Information,
see www.bdub.net/branscombe/

Or contact:

Albert Branscombe
33 Rae Street, P.O. Box 44
Tiverton , ON , N0G 2T0
CANADA

(519) 368-7129 ~ branscoa@bmts.com