

PERFORMANCE ENGINE GASKETS

With the ever-increasing technology in performance and racing engines; supercharged, turbo charged, nitrous oxide and extreme compression ratios, a demand was created for stronger, more durable engine gaskets. Mr. Gasket, the originator of High Performance Gaskets, has met the challenge and developed performance gaskets in a variety of materials for all applications to meet the sealing demands of these engines. Mr. Gasket engine gaskets are the most advanced, tested and proven in the performance market today and earned the respect of many professional and sportsman racers.

CYLINDER HEAD GASKETS

Steel Shim

- Manufactured from .020" steel shim stock
- Stress formed embossment provides excellent sealing
- Increases engine compression, made thinner than OE gasket
- For high performance street, drag race and oval track
- Packaged 2 per set

Ultra-Seal

- Five layer (graphite core/ perforated steel outer layers) composition construction
- Graphite core has excellent thermo-conductivity; transfers heat away from hot spots in head to coolant passages, this prevents gasket burn-out
- Provides excellent stability, compressibility and high temperature endurance
- Will not creep, cold-flow or brinell (indent) aluminum cylinder heads
- For OE replacement, high performance street, drag race and oval track
- Packaged 2 per set

Solicor

- Solid steel core provides radial strength for combustion flange
- Steel wire ring inside flange concentrates sealing load around the combustion chamber
- Provides excellent stability and reduces cylinder bore distortion
- Ideal for supercharged, turbo charged, nitrous oxide and extreme compression ratios
- For high performance street, drag race and oval track
- Packaged 2 per set

MLS (Multi-Layered Steel)

- Manufactured from nitrile coated spring steel layers
- Stress formed embossment provides excellent sealing
- Provides excellent stability and reduces cylinder bore distortion
- Ideal for supercharged, turbo charged, nitrous oxide and extreme compression ratios
- For high performance street, drag race and oval track
- Packaged individually

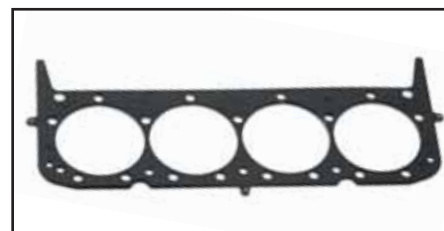
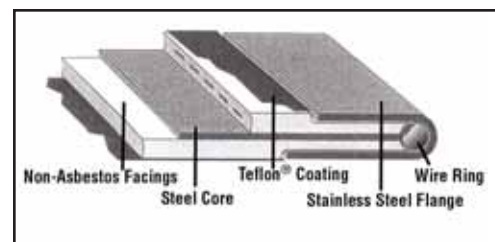
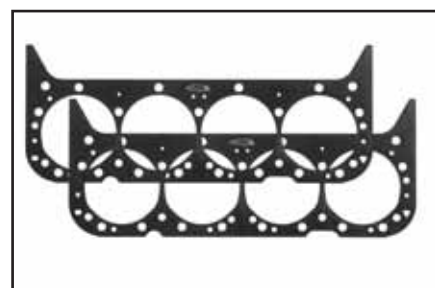
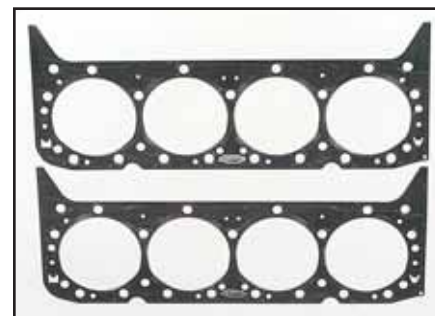

GASKETS

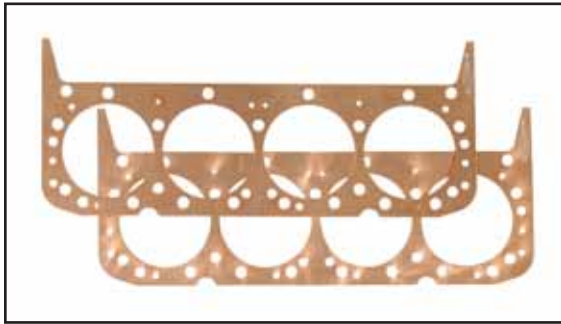

CYLINDER HEAD GASKETS

Copper (Dead Soft)

- Manufactured from dead soft solid copper
- Provides excellent stability and reduces cylinder bore distortion
- Can be used with or without stainless steel o-rings
- Ideal for supercharged, turbo charged, nitrous oxide and extreme compression ratios
- For high performance street, drag race and oval track
- Packaged 2 per set

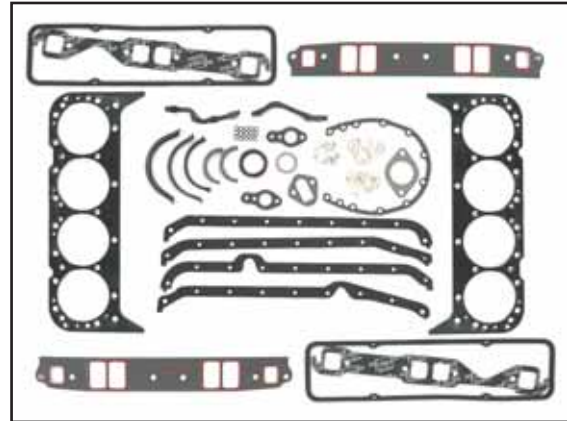

ENGINE OVERHAUL GASKET KITS

Ultra-Seal

The complete overhaul kit contains the following Ultra-Seal gaskets: Cylinder head, intake, exhaust, valve cover and oil pan.

Mr. Gasket distributor (where applicable), timing cover, fuel pump, thermostat, water pump, and rear main seal. For OE replacement, high performance street, drag race and oval track.

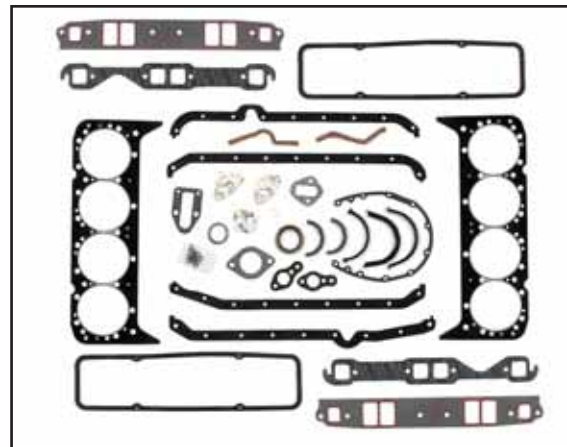

Solicor

The complete kit contains the following gaskets:

Solicor cylinder head gaskets. Ultra-Seal intake, exhaust, valve cover and oil pan.

Mr. Gasket distributor (where applicable), timing cover, fuel pump, thermostat, water pump, and rear main seal. For high performance street, drag race and oval track.



INTAKE GASKETS

Mr. Gasket

- Manufactured from cellulose/nitrile composition gasket material
- Provides excellent sealing and durability
- Can be trimmed if necessary for modified ports
- Complete with manifold end rail seals and distributor gasket
- For OE replacement, high performance street, drag race and oval track
- Packaged 2 per set

INTAKE GASKETS

Ultra-Seal

- Manufactured from cellulose/nitrile composition gasket material
- Provides excellent sealing and durability
- Silicone beading applied around each port to create a tight leak-proof seal
- Can be trimmed if necessary for modified ports
- Complete with manifold end rail seals and distributor gasket
- For OE replacement, high performance street, drag race and oval track
- Packaged 2 per set

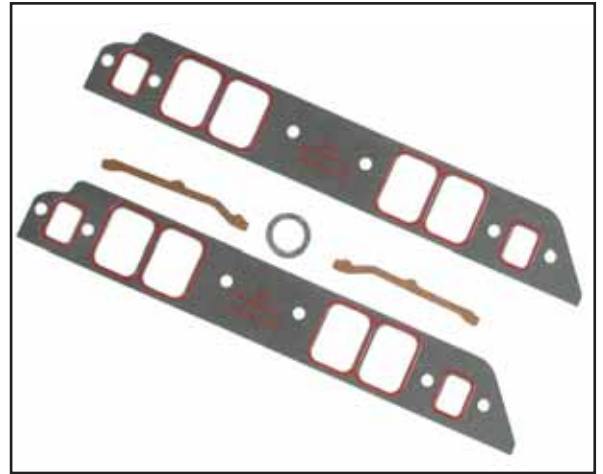

Ultra-Seal II-The Next Generation

Features new gasket sealing technology, a three-part sealing barrier system creates and maintains the ultimate intake manifold to cylinder head seal.

- **Primary Seal:** A formed rubber polymer edge is the primary seal: it conforms easily to flange surface irregularities and maintains sufficient sealing stress after being compressed.
- **Secondary Barrier:** The custom-formed polymer edge creates a second sealing barrier through a controlled process: polymer is intruded into the pores of the base gasket material sealing the edge and making this high-density area an integral part of the gasket.
- **Third Barrier:** The structural carrier provides additional permeation resistance via a special blend of synthetic compounds formed into a 1/16" thick, homogeneous and high-density base material that will not crack or split under excessive clamp load. The engineered matrix provides superior torque retention, crush resistance and shear strength.
- Complete with manifold end rail seals and distributor gasket
- For OE replacement, high performance street, drag race and oval track
- Packaged 2 per set

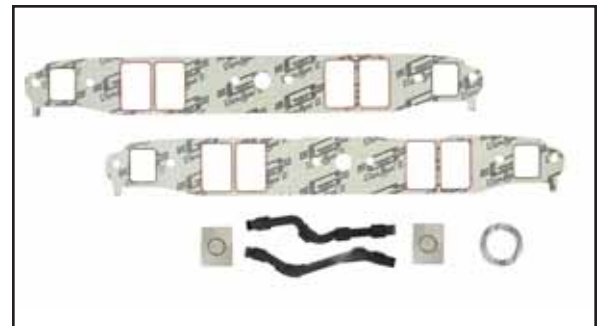

EXHAUST GASKETS

Mr. Gasket

- Manufactured from high-temperature acrylic blend exhaust material
- Provides excellent sealing and durability
- Can be trimmed if necessary for modified ports
- For OE replacement, high performance street, drag race and oval track
- Packaged 2 per set



GASKETS

EXHAUST GASKETS

Ultra-Seal

- Manufactured from high-temperature steel core/graphite faced exhaust material
- Expanded steel core provides stability and maximum torque retention to eliminate gasket failure
- Graphite facing provides excellent heat resistance and thermal conductivity to transfer heat away from the cylinder head
- Conforms to and seals minor surface irregularities
- Can be trimmed if necessary for modified ports
- For OE replacement, high performance street, drag race and oval track
- Packaged 2 per set

CopperSEAL

- Manufactured from dead soft (solid) .043" thick copper material
- Provides excellent sealing and durability
- .051" embossment around each exhaust port to seal irregular surfaces, total gasket thickness .094"
- Conforms to and seals minor surface irregularities
- For high performance street, drag race and oval track
- Packaged 2 per set

PERFORMANCE NOTE: Mr. Gasket was the first manufacturer to incorporate slotted mounting bolt holes at the ends of each exhaust gasket. This allows the gasket to be installed without removing the header flange or exhaust manifold entirely from cylinder head, making installation faster and easier.

VALVE COVER GASKETS

Mr. Gasket

- Manufactured from high-density cork /rubber blend gasket material
- Provides excellent sealing and durability
- Non-shrinking and non-sticking, can be reused many times
- Available in standard or extra thick to provide additional valve train to cover clearance
- For OE replacement, high performance street, drag race and oval track
- Packaged 2 per set

Steel Core

- Manufactured from high-density cork /rubber gasket material laminated to a steel core
- Steel core construction prevents the gasket from being drawn inside or pushed out of engine at high RPM's
- All gaskets are 1/4" thick height to provide additional valve train to cover clearance
- Provides excellent sealing and durability
- Non-shrinking and non-sticking, can be reused many times
- For high performance street, drag race and oval track
- Packaged 2 per set

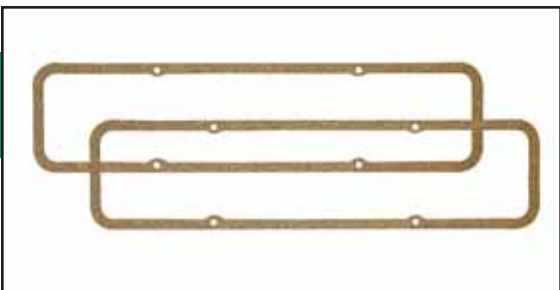
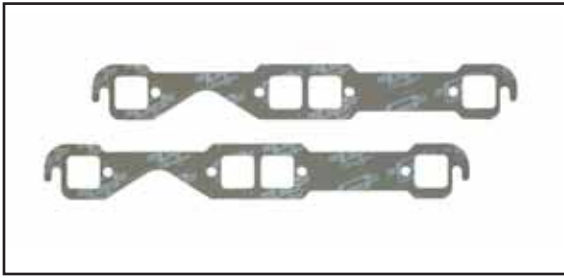

VALVE COVER GASKETS

Ultra-Seal

- Manufactured from high-density cork /rubber blend gasket material
- Creates a positive seal by controlled swelling of the gasket material when exposed to hot engine oil
- A black latex rubber coating is applied to outside of gasket to help seal minor flange irregularities and eliminate the possibility of oil leakage
- Available in standard or extra thick to provide additional valve train to cover clearance
- For OE replacement, high performance street, drag race and oval track
- Packaged 2 per set

Molded Rubber

- Molded rubber valve cover gaskets combine silicone beads and rubber in the gasket material to resist high temperature and compensate for surface irregularities
- Incorporates a steel carrier for stability and proper gasket alignment and torque limiters to prevent over-torque of fasteners and gasket splitting
- Distributes clamp load evenly across the valve cover surface and cylinder head
- Packaged 2 per set

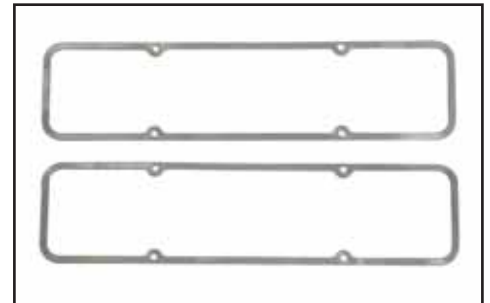
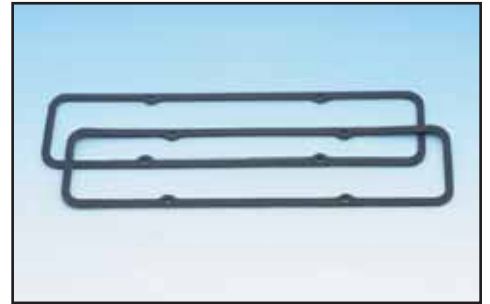

OIL PAN GASKETS

Mr. Gasket

- Manufactured from high-density cork /rubber blend gasket material
- Provides excellent sealing and durability
- Complete with molded rubber front/rear oil pan seals where applicable
- For OE replacement, high performance street, drag race and oval track

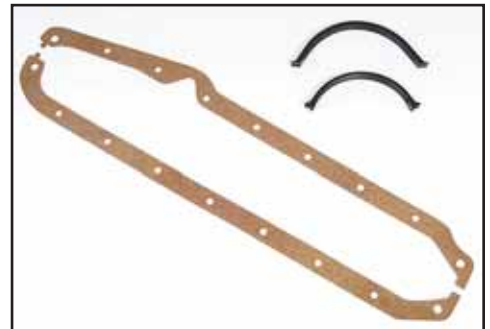

Ultra-Seal

- Manufactured from cellulose/nitrile composition gasket material
- A black latex rubber coating is applied to outside of gasket to help seal minor oil pan rail irregularities and eliminate the possibility of oil leakage
- Provides excellent sealing and durability
- Complete with molded rubber front/rear oil pan seals where applicable
- For OE replacement, high performance street, drag race and oval track

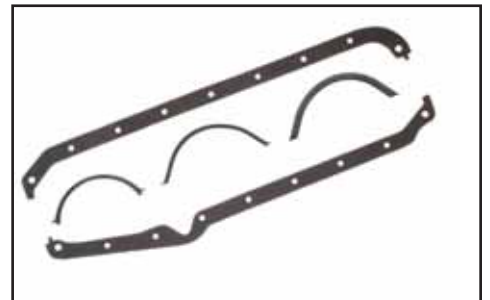

Molded Rubber

- Manufactured from high temperature silicone rubber
- One piece molded construction eliminates potential oil leak paths and provides a tight leakproof seal
- Provides excellent sealing and durability
- For OE replacement, high performance street, drag race and oval track



GASKETS

Chevrolet Small Block V-8, V-6, I-6

ENGINE CID	ENGINE LITERS	CYL.	YEARS	INTAKE SET		EXHAUST SET		VALVE COVER SET		
				MR. GASKET	ULTRA SEAL	MR. GASKET	ULTRA SEAL	MR. GASKET	ULTRA SEAL	
194, 230 250, 292	3.2-4.8	6	1962-89	Intake & Exhaust 155						1
173	2.8	6	1980-89				163			2
200, 229 90 Degree	3.2-3.8	6	1978-84				162			3
262	4.3	6	1986-95			5958				4
265, 283	4.3	8	1955-58	100		6452	5916	175	5860	5
283, 302, 307, 327, 350	4.6-5.7	8	1959-74	101B	5820	6452	5916	175	5860	6
262, 267, 305, 350	4.3-5.7	8	1975-79	101B	5820	6452	5916	175	5860	7
305, 350	5.0-5.7	8	1980-85	101B	5820	6452	5916	175	5860	8
305, 350 W/CFI (4)	5.0-5.7	8	1982-84		5850	6452	5916	175	5860	9
305, 350 W/FI (5)	5.0-5.7	8	1985		5851 Full Set (7)	6452	5916	175	5860	10
305, 350 W/FI (5)	5.0-5.7	8	1986		5851 Full Set (7)	6452	5916	175	5860	11
305, 350 W/FI (5)	5.0-5.7	8	1987-91		5851 Full Set (7)	6452	5916	168 (12)	5867 (12)	12
350 LT1	5.7	8	1992-97	135G			5965	168 (12)	5867 (12)	13
400 V8	6.6	8	1970-74	101B	5820	6452	5916	175	5860	14
400 V8	6.6	8	1975-80	101B	5820	6452	5916	175	5860	15

(2) cork/rubber material (3) composition material (4) cross fire injection (5) tuned port injection (6) does not include #145 upper runner set

(7) includes upper runner set for tuned port injection (9) polyacrylic-single lip

(10) silicone-dual lip (11) silicone-use with align honed 400 (12) for center hold down valve covers

(37) bulk each (38) individually packaged

(39) molded rubber (40) includes early/thin & late/thick front seals (41) aluminum carrier-molded rubber insert (42) composite material

Chevrolet Small Block V-8, V-6, I-6

	OIL PAN SET							
	MR. GASKET	ULTRA SEAL	VALVE GRIND KIT	CAM CHANGE KIT	REAR MAIN SEAL	TIMING COVER SEAL	TIMING COVER	WATER OUTLET
1								
2						18		
3					1960 ⁽¹⁰⁾ 1961 ⁽⁹⁾	18		740 ⁽³⁷⁾ 740C ⁽³⁸⁾ 738G ⁽⁴¹⁾
4					29	18	90 ⁽²⁾ 93 ⁽⁴²⁾	740 ⁽³⁷⁾ 740C ⁽³⁸⁾ 738G ⁽⁴¹⁾
5	196 ⁽³⁾ 190 ⁽²⁾	5880 5884 ⁽⁴⁰⁾				18	90 ⁽²⁾ 93 ⁽⁴²⁾	740 ⁽³⁷⁾ 740C ⁽³⁸⁾ 738G ⁽⁴¹⁾
6	196 ⁽³⁾ 190 ⁽²⁾	5880 5884 ⁽⁴⁰⁾	3953	4400	1960 ⁽¹⁰⁾ 1961 ⁽⁹⁾	18	90 ⁽²⁾ 93 ⁽⁴²⁾	740 ⁽³⁷⁾ 740C ⁽³⁸⁾ 738G ⁽⁴¹⁾
7	198 ⁽³⁾ 189 ⁽²⁾ 6560 ⁽³⁹⁾	5881 5884 ⁽⁴⁰⁾		4403	1960 ⁽¹⁰⁾ 1961 ⁽⁹⁾	18	90 ⁽²⁾ 93 ⁽⁴²⁾	740 ⁽³⁷⁾ 740C ⁽³⁸⁾ 738G ⁽⁴¹⁾
8	185 ⁽²⁾ 6560 ⁽³⁹⁾	5882		4406	1960 ⁽¹⁰⁾ 1961 ⁽⁹⁾	18	90 ⁽²⁾ 93 ⁽⁴²⁾	740 ⁽³⁷⁾ 740C ⁽³⁸⁾ 738G ⁽⁴¹⁾
9	185 ⁽²⁾ 6560 ⁽³⁹⁾	5882		4400	1960 ⁽¹⁰⁾ 1961 ⁽⁹⁾	18	90 ⁽²⁾ 93 ⁽⁴²⁾	740 ⁽³⁷⁾ 740C ⁽³⁸⁾ 738G ⁽⁴¹⁾
10	185 ⁽²⁾ 6560 ⁽³⁹⁾	5882		4406	1960 ⁽¹⁰⁾ 1961 ⁽⁹⁾	18	90 ⁽²⁾ 93 ⁽⁴²⁾	740 ⁽³⁷⁾ 740C ⁽³⁸⁾ 738G ⁽⁴¹⁾
11	185 ⁽²⁾ 6560 ⁽³⁹⁾	5882		4408 ⁽⁶⁾	29	18	90 ⁽²⁾ 93 ⁽⁴²⁾	740 ⁽³⁷⁾ 740C ⁽³⁸⁾ 738G ⁽⁴¹⁾
12	199 ⁽²⁾ 6561 ⁽³⁹⁾	5885		4407 ⁽⁶⁾	29	18	90 ⁽²⁾ 93 ⁽⁴²⁾	
13	199 ⁽²⁾ 6561 ⁽³⁹⁾	5885			29	18		
14	196 ⁽³⁾ 190 ⁽²⁾	5880 5884 ⁽⁴⁰⁾		4400	1960 ⁽¹⁰⁾ 1961 ⁽⁹⁾ 1962 ⁽¹¹⁾	18	90 ⁽²⁾ 93 ⁽⁴²⁾	740 ⁽³⁷⁾ 740C ⁽³⁸⁾ 738G ⁽⁴¹⁾
15	198 ⁽³⁾ 189 ⁽²⁾ 6560 ⁽³⁹⁾	5881 5884 ⁽⁴⁰⁾		4403	1960 ⁽¹⁰⁾ 1961 ⁽⁹⁾ 1962 ⁽¹¹⁾	18	90 ⁽²⁾ 93 ⁽⁴²⁾	740 ⁽³⁷⁾ 740C ⁽³⁸⁾ 738G ⁽⁴¹⁾

See pages 138-139 for Modified Port applications
See pages 136-137 for Head Gasket applications

GASKETS

CYLINDER HEAD GASKET APPLICATIONS AND SPECIFICATIONS

Chevrolet Small Block V-8, V-6, I-6

Mr. Gasket Head Gaskets							
ENGINE CID	ENGINE LITERS	CYL.	YEARS	DESCRIPTION	GASKET BORE	COMPRESSED THICKNESS	PART NO.
283-350	4.6-5.7	8	1957-91	Steel Shim - Embossed, Elastomer Coated, Does Not Fit 305 Light Weight Head, See Drawing Page 140	4.100"	.020"	1130
283-350	4.6-5.7	8	1957-91	Steel Shim - Embossed, Elastomer Coated, Does Not Fit 305 Light Weight Head, See Drawing Page 140	4.140"	.020"	1052
283-350	4.6-5.7	8	1957-91	Steel Shim - Embossed, Elastomer Coated, Does Not Fit 305 Light Weight Head, See Drawing Page 140	4.050"	.043"	5360 (45)
400	6.6	8	1970-80	Copper (Dead Soft), For Off Road Use, No Steam Holes	4.170"	.043"	5361 (45)
Note: Most head gaskets are packaged 2 per set, astrisk (*) designates individually packaged. (45) o-rings are recommended to seal combustion pressure, high temp RTV silicone sealer (red) is recommended to seal coolant and oil ports in copper head gaskets.							
Ultra-Seal Head Gaskets							
ENGINE CID	ENGINE LITERS	CYL.	YEARS	DESCRIPTION	GASKET BORE	COMPRESSED THICKNESS	PART NO.
194, 230, 250, 292 I-6	3.2-4.8	6	1963-89	Flexible Graphite Core, Elastomer Coated	4.000"	.038"	5785 *
229, 262 V6 90 Deg.	3.8-4.3	6	1980-90	Flexible Graphite Core, Elastomer Coated Asymmetric Bore	4.160"	.038"	5782
229, 262 V6 90 Deg.	3.8-4.3	6	1980-90	Flexible Graphite Core, Elastomer Coated Symmetric Bore	4.130"	.028"	5787
262, 265, 267, 305	4.3-5.0	8	1955-91	Flexible Graphite Core, Elastomer Coated	3.870"	.028"	5780
283-350	4.6-5.7	8	1957-91	Flexible Graphite Core, Elastomer Coated	4.130"	.038"	5800
283-350	4.6-5.7	8	1957-91	Flexible Graphite Core, Elastomer Coated	4.130"	.055"	5799
283-350	4.6-5.7	8	1957-91	Flexible Graphite Core, Elastomer Coated	4.130"	.028"	1134
350	5.7	8	1992-97	Flexible Graphite Core, Elastomer Coated, LT1, LT4 Aluminum Head	4.120"	.046"	5715
350	5.7	8	1992-97	Flexible Graphite Core, Elastomer Coated, LS1 Steel Head	4.110"	.026"	5716
350	5.7	8	1997-03	Flexible Graphite Core, Elastomer Coated, LS1 Left Side	4.000"	.051"	5713G *
350	5.7	8	1997-03	Flexible Graphite Core, Elastomer Coated, LS1 Right Side	4.000"	.051"	5714G *
400	6.6	8	1970-80	Flexible Graphite Core, Elastomer Coated, For Street Use, With Required Steam Holes	4.190"	.038"	5801
Note: Most head gaskets are packaged 2 per set, astrisk (*) designates individually packaged.							

CYLINDER HEAD GASKET APPLICATIONS AND SPECIFICATIONS

Chevrolet Small Block V-8, V-6, I-6

Sollicor Head Gaskets							
ENGINE CID	ENGINE LITERS	CYL.	YEARS	DESCRIPTION	GASKET BORE	COMPRESSED THICKNESS	PART NO.
173 V6 60 Deg.	2.8	6	1980-86	Solid Steel Core Center, Laminated Outer Facing	3.620"	.042"	5723
229, 262 V6 90 Deg.	3.8-4.3	6	1985-93	Solid Steel Core Center, Laminated Outer Facing	4.200"	.042"	5724
283-350	4.6-5.7	8	1957-96	Solid Steel Core Center, Laminated Outer Facing Does Not Fit LT1 92-96	4.190"	.044"	5727
400	6.6	8	1970-80	Solid Steel Core Center, Laminated Outer Facing For Street Use, W/Required Steam Holes	4.220"	.042"	5728
400	6.6	8	1970-80	Solid Steel Core Center, Laminated Outer Facing Off Road Use, No Steam Holes	4.220"	.042"	5729

Note: Most head gaskets are packaged 2 per set, astrisk (*) designates individually packaged.

MLS (Multi-Layered Steel) Head Gaskets

ENGINE CID	ENGINE LITERS	CYL.	YEARS	DESCRIPTION	GASKET BORE	COMPRESSED THICKNESS	PART NO.
283-350	4.6-5.7	8	1957-96	Embossed Multi-Layered Steel Gasket Does Not Fit Aftermarket Heads With Larger Than OE Water Jacket Ports	4.060"	.040"	3130G *
283-350	4.6-5.7	8	1957-96	Embossed Multi-Layered Steel Gasket Does Not Fit Aftermarket Heads With Larger Than OE Water Jacket Ports	4.125"	.040"	3131G *
283-350	4.6-5.7	8	1957-96	Embossed Multi-Layered Steel Gasket Does Not Aftermarket Heads With Larger Than OE Water Jacket Ports	4.165"	.040"	3132G *
283-350	4.6-5.7	8	1957-96	Embossed Multi-Layered Steel Gasket Does Not Fit Aftermarket Heads With Larger Than OE Water Jacket Ports	4.200"	.040"	3133G *
350 SB2-2	5.7	8	N/A	Embossed Multi-Layered Steel Gasket	4.125"	.040"	3137G *
350 SB2-2	5.7	8	N/A	Embossed Multi-Layered Steel Gasket	4.165"	.040"	3138G *
350 SB2-2	5.7	8	N/A	Embossed Multi-Layered Steel Gasket	4.200"	.040"	3139G *
350 LT1	5.7	8	1992-97	Embossed Multi-Layered Steel Gasket	4.040"	.040"	3140G *
350 LT1	5.7	8	1992-97	Embossed Multi-Layered Steel Gasket	4.100"	.040"	3141G *
350 LS1	5.7	8	1997-03	Embossed Multi-Layered Steel Gasket	4.125"	.054"	3143G *
350 LS1	5.7	8	1997-03	Embossed Multi-Layered Steel Gasket	4.160"	.054"	3144G *
350 LS1	5.7	8	1997-03	Embossed Multi-Layered Steel Gasket	4.190"	.054"	3145G *

Note: Most head gaskets are packaged 2 per set, astrisk (*) designates individually packaged.

PERFORMANCE OVERHAUL GASKET KITS

Chevrolet Small Block V-8

ENGINE CID	ENGINE LITERS	CYL	YEARS	OVERHAUL KITS	
				ULTRA SEAL	SOLICOR
283 302, 307, 327, 350	4.6-5.7	8	1957-74	5991	6600G
350	5.7	8	1975-79	5991	6600G
350	5.7	8	1980-85	5991 ⁽⁶⁾	6600G ⁽⁶⁾
350 W/FI	5.7	8	1986	5993 ⁽⁶⁾	
350 W/FI	5.7	8	1986-91	5992 ⁽⁶⁾	

⁽⁶⁾ does not include #145 upper runner set

GASKETS

INTAKE GASKET SPECIFICATIONS AND MODIFIED PORT APPLICATIONS

Chevrolet Small Block V-8 & V-6

STOCK AND PERFORMANCE CYLINDER HEADS									
CONVENTIONAL PORT AND BOLT HOLE LOCATIONS									
ENGINE CID	ENGINE LITERS	CYL.	YEARS	DESCRIPTION	APPLICATION	PORT DIMENSIONS	INTAKE SET		ULTRA SEAL II
							MR. GASKET	ULTRA SEAL	
265-283	4.3-4.6	8	1955-67	1/16" Thick	Stock Port	1.20w x 1.87h	100 ⁽¹³⁾		
262-400	4.3-4.6	8	1955-91	1/16" Thick	Stock Port	1.25w x 2.00h	101B ⁽¹³⁾	5820	810G
262-400	4.3-4.6	8	1955-91	1/16" Thick	Sm Race Port	1.25w x 2.13h		5821	
262-400	4.3-4.6	8	1955-91	1/16" Thick	Med Race Port	1.31w x 2.10h	101G ⁽¹³⁾		
262-400	4.3-4.6	8	1955-91	1/8" Thick	Med Race Port	1.31w x 2.10h	106		
262-400	4.3-4.6	8	1955-91	1/16" Thick	Med Race Port	1.31w x 2.19h	102	5822	
262-400	4.3-4.6	8	1955-91	1/8" Thick	Med Race Port	1.31w x 2.19h	116	5812	
262-400	4.3-4.6	8	1955-91	1/16" Thick	Lrg Race Port	1.31w x 2.31h	111	5823	
262-400	4.3-4.6	8	1955-91	1/8" Thick	Lrg Race Port	1.31w x 2.31h	113	5813	
262-400	4.3-4.6	8	1955-91	1/16" Thick	Ext Lrg Race Port	1.38w x 2.38h	123	5824	
262-400	4.3-4.6	8	1955-91	1/8" Thick	Ext Lrg Race Port	1.38w x 2.38h	124	5814	
350	5.7	8	1992-97	1/16" Thick	LT1	1.24w x 2.06h	135G		
350	5.7	8	1997-00	1/8" Thick	Vortec Design Port	1.31w x 2.37h	136G		
305-350	5.0-5.7	8	1985-92	1/16" Thick	TPI Upper Runner	1.50 Dia.	145		
305-350	5.0-5.7	8	1985-92	1/16" Thick	TPI Upper Runner	1.75 Dia.	146		
350	5.7	8	1982-84	1/16" Thick	Stock Port	1.25w x 2.00h		5850	
305-350	5.0-5.7	8	1985-91	1/16" Thick	Stock Port	1.25w x 2.00h		5851 ⁽¹⁴⁾	811G ⁽¹⁵⁾

(13) includes steel heat riser block off plates
 (14) includes upper runner set TPI and throttle body base gasket
 (15) includes TPI throttle body base gasket

PERFORMANCE CYLINDER HEADS							
NON-CONVENTIONAL PORT AND BOLT HOLE LOCATIONS							
ENGINE CID	ENGINE LITERS	CYL.	YEARS	DESCRIPTION	APPLICATION	PORT DIMENSIONS	INTAKE SET MR. GASKET
200-229	3.3-3.8	6	1978-84	1/16" Thick	Lrg Race Port	1.25w x 2.13h	130
200-229	3.3-3.8	6	1978-84	1/8" Thick	Lrg Race Port	1.25w x 2.13h	132
262-400	4.3-4.6	8	1955-91	1/16" Thick	Raised Runner & Pontiac "867"	1.32w x 2.13h	103
262-400	4.3-4.6	8	1955-91	1/16" Thick	Splayed Valve	1.60w x 2.02h	104
262-400	4.3-4.6	8	1955-91	1/16" Thick	SB2.2 Valley Cvr	N.A.	360G
262-400	4.3-4.6	8	1955-91	1/32" Thick	SB2.2	1.60w x 2.13h	361
262-400	4.3-4.6	8	1955-91	1/16" Thick	SB2.2	1.60w x 2.13h	362G
262-400	4.3-4.6	8	1955-91	3/32" Thick	SB2.2	1.60w x 2.13h	363G
262-400	4.3-4.6	8	1955-91	1/8" Thick	SB2.2	1.60w x 2.13h	364G
262-400	4.3-4.6	8	1955-91	1/16" Thick	Brodix Aluminum	1.38w x 2.25h	125
262-400	4.3-4.6	8	1955-91	1/8" Thick	Brodix Aluminum	1.38w x 2.25h	126
262-400	4.3-4.6	8	1955-91	1/16" Thick	Brodix Alum -12	1.38w x 2.38h	140
262-400	4.3-4.6	8	1955-91	1/8" Thick	Brodix Alum -12	1.38w x 2.38h	141
262-400	4.3-4.6	8	1955-91	1/16" Thick	18 Deg. Roll Over	1.35w x 2.26h	143
262-400	4.3-4.6	8	1955-91	1/8" Thick	18 Deg. Roll Over	1.35w x 2.26h	144
262-400	4.3-4.6	8	1955-91	1/16" Thick	SBC/Buick Corp	1.37w x 2.30h	610~

EXHAUST GASKET SPECIFICATIONS AND MODIFIED PORT APPLICATIONS

Chevrolet Small Block V-8 & V-6

ENGINE CID	ENGINE LITERS	CYL.	YEARS	DESCRIPTION	PORT DIMENSIONS	MR. GASKET	ULTRA SEAL	COPPER SEAL
262	4.3	6	1985-95	Stock Port	1.55w x 1.63h		5958	
262-400	4.3-6.6	8	1955-99	Large Race Square Ports	1.45w x 1.55h	150A	5901	7153
262-400	4.3-6.6	8	1955-99	Medium Race Square Ports	1.45w x 1.48h	150C	5900	7151
262-400	4.3-6.6	8	1955-99	Stock Square Ports	1.25w x 1.30h	6452	5916	
262-400	4.3-6.6	8	1955-99	Extra Large Square Ports	1.50w x 1.65h	150D		
262-400	4.3-6.6	8	1955-99	Round Port- For Headers	1.50 DIA.	150B	5907	7150
262-400	4.3-6.6	8	1955-99	Round Port - For Headers	1.63 DIA.	150	5902	7152G
262-400	4.3-6.6	8	1955-99	Brodix D-Shaped Port	1.55w x 1.71h		5903	
262-400	4.3-6.6	8	1955-99	Hooker, Stahl Combination Adapter Plate	1.93 DIA.		5904	
262-400	4.3-6.6	8	1955-99	Hooker Combination Reversion Plate/Stock Port	1.61w x 1.85h		5908	
262-400	4.3-6.6	8	1955-99	Hooker Reversion Plate For 2 1/8" Headers	1.53w x 1.65h		5905	
262-400	4.3-6.6	8	1955-99	Brodix Spread Port Aluminum Heads	1.65w x 1.60h		5906	
262-400	4.3-6.6	8	1955-99	Stage 6 Aluminum Heads	1.41w x 1.50h		5909	
262-400	4.3-6.6	8	1955-99	Cyclone Adapter Plate	1.77 DIA.		5915	
262-400	4.3-6.6	8	1955-99	Late BlackJack, Cyclone Oval Port	1.50w x 1.82h Oval		5917	
262-400	4.3-6.6	8	1955-99	Buick Dart Heads	1.52w x 1.35h		5957	
262-400	4.3-6.6	8	1955-99	18 Deg. Roll Over Head (Head Side)	1.74 DIA.		5918	
262-400	4.3-6.6	8	1955-99	18 Deg. Roll Over Head (Adapter Plate Side)	2.05 DIA.		5919	
262-400	4.3-6.6	8	1955-99	Splayed Valve (Adapter Plate Side)	1.74 DIA.		5923	
262-400	4.3-6.6	8	1955-99	Splayed Valve (Head Side)	1.75 DIA.		5924	
262-400	4.3-6.6	8	1955-99	Splayed Valve, (Head Side)	2.13 DIA.		5926	
281-365	4.6-6.0	8	1997-04	LD8,LR4,L30, LM7,LS1, LS6, LQ4 Round Port	1.75 DIA.		5964	
350	5.7	8	1992-96	LT1, LT4 D-Shaped Port	1.50w x 1.50h		5965	7154
350	5.7	8	1996-Up	SB2.2 Head	1.92 DIA.		7500	
262-400	4.3-6.6	8	1955-99	Brodix 12B Raised D-Shaped Port	1.78w x 1.70h		7501	
262-400	4.3-6.6	8	1955-99	Vortec L31 Head	1.50 DIA.		7505	



GASKETS

VALVE COVER GASKET APPLICATIONS AND SPECIFICATIONS

Chevrolet Small Block V-8

ENGINE CID	ENGINE LITERS	CYL.	YEARS	DESCRIPTION	MR. GASKET	ULTRA SEAL
305, 350	5.0-5.7	8	1987-97	Center Bolt Design, 3/16" Thick	168	5867
265-400	4.3-6.6	8	1955-86	3/16" Thick	175, 585G ⁽³⁹⁾ 5853G ⁽³⁹⁾	5860
265-400	4.3-6.6	8	1955-86	5/16" Thick	179	5861
265-400	4.3-6.6	8	1955-86	1/4" Thick, Steel Core	5855	
265-400	4.3-6.6	8	1955-86	5/16" Thick, Notched to clear relocated rocker arm studs and Jesel shaft assemblies	5864	
265-400	4.3-6.6	8	1955-86	1/16" Thick, For Dart Buick Heads. Notched to clear relocated rocker arm studs and Jesel shaft assemblies	677	
265-400	4.3-6.6	8	1955-86	1/4" Thick, Steel Core for Dart Buick Heads	5873	
265-400	4.3-6.6	8	1955-86	1/16" Thick, For Splayed Valve Heads	169	
265-400	4.3-6.6	8	N/A	1/16" Thick, For SB2/SB2.2 Heads	181	
265-400	4.3-6.6	8	N/A	1/16" Thick, For Dart Little Chief Heads	172G	

⁽³⁹⁾ Molded Rubber

WATER OUTLET GASKET FOR CHEVROLET

This gasket is composed of an aluminum carrier with a molded silicone bead to ensure a secure seal. Seals surface irregularities between manifold and water outlet housing, compatible with all intake manifold materials.

265-400 55-88.....738G



738G▲

GM HEAD IDENTIFICATION

305, 350 cu. in.

Mr. Gaskets ULTRA-SEAL #5800 & 5801 head gaskets will work GM's **standard and lightweight cylinder head**. Mr. Gasket #1130 Embossed Steel Shim head gasket **will work** with GM's standard head **but should not be used with lightweight head**, there is not enough material on bottom of cylinder head casting to seal steel shim head gasket properly. Refer to drawings for difference in head design.

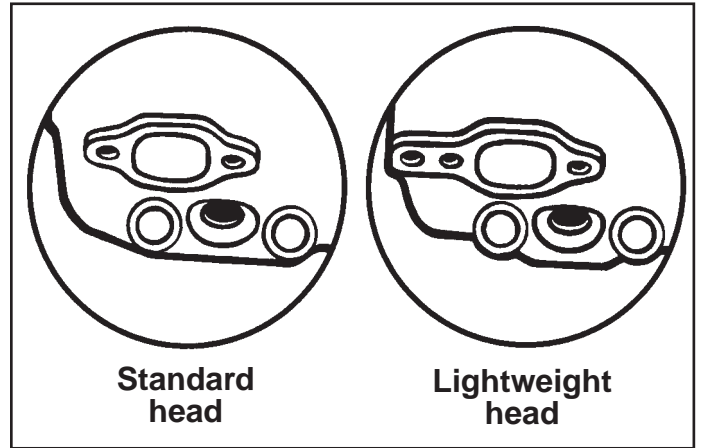

4327▲

FENDER COVER

Protect the paint on your fender from grease, scratches and nicks with Mr. Gasket's Fender Cover. This attractive vinyl cover features a non-slip back and seams, which forms a natural "pocket" that prevents tools from rolling off. Black with logos.

Fender Cover.....4327



4362▲

ENGINE PORT POLISHING KIT

Mr. Gasket's Port Polishing Kit is designed for use on cast iron and aluminum components. This kit allows you to do your own detailed porting, polishing, and removal of flashing on all engine parts with the use of an electric drill. The kit contains (1) tapered cutting stone, (1) 1" diameter mini grind-flex flat wheel, (29) grind-polishing rolls (assorted sizes), and (3) various length mandrels.

Engine Port Polishing Kit.....4362

GASKETS

Chevrolet Big Block V-8

ENGINE CID	ENGINE LITERS	CYL.	YEARS	INTAKE SET		EXHAUST SET		VALVE COVER SET		
				MR. GASKET	ULTRA SEAL	MR. GASKET	ULTRA SEAL	MR. GASKET	ULTRA SEAL	
396, 402 Gen IV	6.5-6.6	8	1965-72	107 Oval Port	5827 Oval Port	153	5910	177 5854G ⁽³⁹⁾	5862	1
396, 402 Hi-Perf Gen IV	6.5-6.6	8	1965-72	108 Rec. Port	5828 Rec. Port	153	5910	177 5854G ⁽³⁹⁾	5862	2
427, 454 Gen IV	6.5-7.5	8	1965-90	107 Oval Port	5827 Oval Port	153	5910	177 5854G ⁽³⁹⁾	5862	3
427, 454 Hi-Perf Gen IV	6.5-7.5	8	1965-90	108 Rec. Port	5828 Rec. Port	153	5910	177 5854G ⁽³⁹⁾	5862	4
454-502 Gen V, VI	7.5-8.2	8	1991-00	119G Oval Port		153	5910			5

(2) cork/rubber material

(3) composition material

(16) mountain motor 9 mounting bolt holes

(23) composite material

(37) bulk each ⁽³⁸⁾ individually packaged

(39) molded rubber

(41) aluminum carrier-molded rubber insert

(42) composite material



4327▲

FENDER COVER

Protect the paint on your fender from grease, scratches and nicks with Mr. Gasket's Fender Cover. This attractive vinyl cover features a non-slip back and seams, which forms a natural "pocket" that prevents tools from rolling off. Black with logos.

Fender Cover.....4327



7808▲

BLUE RTV SILICONE SEALER

The original blue. Makes reliable "formed-in-place" gaskets. Resists cracking, shrinking and migrating. Coats pre-cut gaskets to increase reliability. Temperature range -65°F to 500°F intermittent; resists auto and shop fluids.

Application includes valve covers, oil pans, intake manifold end seals, timing covers, water pumps, thermostat housings.

Blue RTV Silicone Sealer 3 oz. tube7808

Chevrolet Big Block V-8

	OIL PAN SET						
	MR. GASKET	ULTRA SEAL	CAM CHANGE KIT	REAR MAIN SEAL	TIMING COVER SEAL	TIMING COVER	WATER OUTLET
1	192 ⁽³⁾ 195 ⁽¹⁶⁾ , 197 ⁽²³⁾ , 6663G ⁽³⁹⁾	5883	4405	1969	17	90A ⁽²⁾ 94 ⁽⁴²⁾	740 ⁽³⁷⁾ 740C ⁽³⁸⁾ 738G ⁽⁴¹⁾
2	192 ⁽³⁾ 195 ⁽¹⁶⁾ , 197 ⁽²³⁾ , 6663G ⁽³⁹⁾	5883	4404	1969	17	90A ⁽²⁾ 94 ⁽⁴²⁾	740 ⁽³⁷⁾ 740C ⁽³⁸⁾ 738G ⁽⁴¹⁾
3	192 ⁽³⁾ 195 ⁽¹⁶⁾ , 197 ⁽²³⁾ , 6663G ⁽³⁹⁾	5883	4405	1969	17	90A ⁽²⁾ 94 ⁽⁴²⁾	740 ⁽³⁷⁾ 740C ⁽³⁸⁾ 738G ⁽⁴¹⁾
4	192 ⁽³⁾ 195 ⁽¹⁶⁾ , 197 ⁽²³⁾ , 6663G ⁽³⁹⁾	5883	4404	1969	17	90A ⁽²⁾ 94 ⁽⁴²⁾	740 ⁽³⁷⁾ 740C ⁽³⁸⁾ 738G ⁽⁴¹⁾
5	6664G ⁽³⁹⁾			34G	17		

See pages 146-147 for Modified Port applications
See pages 144-145 for Head Gasket applications



4362▲

ENGINE PORT POLISHING KIT

Mr. Gasket's Port Polishing Kit is designed for use on cast iron and aluminum components. This kit allows you to do your own detailed porting, polishing, and removal of flashing on all engine parts with the use of an electric drill. The kit contains (1) tapered cutting stone, (1) 1" diameter mini grind-flex flat wheel, (29) grind-polishing rolls (assorted sizes), and (3) various length mandrels.

Engine Port Polishing Kit4362



3795G▲

ENGINE OIL PRIMER

Priming the engine is an important precautionary measure that should be taken before you start the engine for the first time. Engineered to fit into the distributor aperture and operate with an electric hand drill, the engine oil primer pressurizes the oil system, assuring the lubrication of vital bearing surfaces.

All Chevrolet V-8 and 6 cyl., Pontiac V-83795G

GASKETS

CYLINDER HEAD GASKET APPLICATIONS AND SPECIFICATIONS

Chevrolet Big Block V-8

Mr. Gasket Head Gaskets							
ENGINE CID	ENGINE LITERS	CYL.	YEARS	DESCRIPTION	GASKET BORE	COMPRESSED THICKNESS	PART NO.
396-454 Gen IV	6.5-7.5	8	1965-90	Steel Shim - Embossed	4.370"	.020"	1131
396-454 Gen IV	6.5-7.5	8	1965-90	Copper (Dead Soft)	4.320"	.043"	1055 (45)
396-454 Gen IV	6.5-7.5	8	1965-90	Copper (Dead Soft)	4.500"	.043"	5362 (45)
396-454 Gen IV	6.5-7.5	8	1965-90	Copper (Dead Soft)	4.600"	.043"	5363 (45)

Note: Most head gaskets are packaged 2 per set, astrisk (*) designates individually packaged.

(45) o-rings are recommended to seal combustion pressure, hylomar is recommended to seal coolant ports in copper head gaskets.

Ultra-Seal Head Gaskets

ENGINE CID	ENGINE LITERS	CYL.	YEARS	DESCRIPTION	GASKET BORE	COMPRESSED THICKNESS	PART NO.
396-454 Gen IV	6.5-7.5	8	1965-90	Flexible Graphite Core, Elastomer Coated	4.520"	.038"	5802
454, 502 Gen V, VI	7.5-8.2	8	1991-99	Flexible Graphite Core, Elastomer Coated	4.520"	.038"	5804

Note: Most head gaskets are packaged 2 per set, astrisk (*) designates individually packaged.

Solicor Head Gaskets

ENGINE CID	ENGINE LITERS	CYL.	YEARS	DESCRIPTION	GASKET BORE	COMPRESSED THICKNESS	PART NO.
396-454 Gen IV	6.5-7.5	8	1965-90	Solid Steel Core, Steel Wire Ring Encased In Stainless Steel Combustion Flange	4.370"	.042"	5730
396-454 Gen IV	6.5-7.5	8	1965-90	Solid Steel Core, Steel Wire Ring Encased In Stainless Steel Combustion Flange	4.620"	.042"	5731
396-454 Gen IV	6.5-7.5	8	1965-90	Solid Steel Core, Steel Wire Ring Encased In Stainless Steel Combustion Flange	4.620"	.051"	5732
454, 502 Gen V, VI	7.5-8.2	8	1991-99	Solid Steel Core, Steel Wire Ring Encased In Stainless Steel Combustion Flange	4.370"	.042"	5733
454, 502 Gen V, VI	7.5-8.2	8	1991-99	Solid Steel Core, Steel Wire Ring Encased In Stainless Steel Combustion Flange	4.540"	.042"	5735

Note: Most head gaskets are packaged 2 per set, astrisk (*) designates individually packaged.

CYLINDER HEAD GASKET APPLICATIONS AND SPECIFICATIONS

Chevrolet Big Block V-8

MLS (Muti-Layered Steel) Head Gaskets							
ENGINE CID	ENGINE LITERS	CYL.	YEARS	DESCRIPTION	GASKET BORE	COMPRESSED THICKNESS	PART NO.
396-454 Gen IV	6.5-7.5	8	1965-90	Nitrile Coated Outer Layers - Embossed, W/Steel Inner Spacer	4.370"	.040"	3150G *
396-454 Gen IV	6.5-7.5	8	1965-90	Nitrile Coated Outer Layers - Embossed, W/Steel Inner Spacer	4.540"	.040"	3151G *
396-454 Gen IV	6.5-7.5	8	1965-90	Nitrile Coated Outer Layers - Embossed, W/Steel Inner Spacer	4.620"	.040"	3152G *
454, 502 Gen V, VI	7.5-8.2	8	1991-99	Nitrile Coated Outer Layers - Embossed, W/Steel Inner Spacer	4.370"	.040"	3156G *
454, 502 Gen V, VI	7.5-8.2	8	1991-99	Nitrile Coated Outer Layers - Embossed, W/Steel Inner Spacer	4.540"	.040"	3157G *
454, 502 Gen V, VI	7.5-8.2	8	1991-99	Nitrile Coated Outer Layers - Embossed, W/Steel Inner Spacer	4.620"	.040"	3158G *

Note: Most head gaskets are packaged 2 per set, astrisk (*) designates individually packaged.

PERFORMANCE OVERHAUL GASKET KITS					
Chevrolet Big Block V-8					
ENGINE CID	ENGINE LITERS	CYL	YEARS	OVERHAUL KITS	
				ULTRA SEAL	SOLICOR
396, 402 Gen IV	6.5-6.6	8	1965-72	5996 Oval Port	6601G Oval Port
396, 402 Hi-Perf Gen IV	6.5-6.6	8	1965-72	5995 Rect Port	6602G Rect Port
427, 454 Gen IV	7.0-7.5	8	1966-90	5996 Oval Port	6601G Oval Port
427, 454 Hi-Perf Gen IV	7.0-7.5	8	1966-90	5995 Rect Port	6602G Rect Port

GASKETS

INTAKE GASKET SPECIFICATIONS AND MODIFIED PORT APPLICATIONS

Chevrolet Big Block V-8

STOCK AND PERFORMANCE CYLINDER HEADS									
CONVENTIONAL PORT AND BOLT HOLE LOCATIONS									
ENGINE CID	ENGINE LITERS	CYL.	YEARS	DESCRIPTION	APPLICATION	PORT DIMENSIONS	INTAKE SET		ULTRA SEAL II
							MR. GASKET	ULTRA SEAL	
396-454 Gen IV	6.5-7.4	8	1965-90	1/16" Thick	Oval Stock Port	1.75W x 2.16H	107	5827	820G
396-454 Gen IV	6.5-7.4	8	1965-90	1/8" Thick	Oval Stock Port	1.75W x 2.16H	117		
396-454 Gen IV	6.5-7.4	8	1965-90	1/16" Thick	Rect Stock Port	1.75W x 2.50H	108	5828	821G
396-454 Gen IV	6.5-7.4	8	1965-90	1/8" Thick	Rect Stock Port	1.75W x 2.50H	110	5818	
454 Gen V	7.4	8	1991-95	1/16" Thick	Oval Stock Port	1.85W x 2.16H	119G		

PERFORMANCE CYLINDER HEADS									
NON-CONVENTIONAL PORT AND BOLT HOLE LOCATIONS									
ENGINE CID	ENGINE LITERS	CYL.	YEARS	DESCRIPTION	APPLICATION	PORT DIMENSIONS	INTAKE SET		
							MR. GASKET	ULTRA SEAL	
396-454 Gen IV	6.5-7.4	8	1965-90	1/16" Thick	Rect Raised Port	1.75 W x 2.50H	121	5817 *5829	
396-454 Gen IV	6.5-7.4	8	1965-90	1/8" Thick	Rect Raised Port	1.75 W x 2.50H	122	5819	
396-454 Gen IV	6.5-7.4	8	1965-90	1/16" Thick	Dart Big Chief	1.83W x 2.43H	420		
396-454 Gen IV	6.5-7.4	8	1965-90	1/16" Thick	Dart Big "M"	1.84W x 2.80H	425		
396-454 Gen IV	6.5-7.4	8	1965-90	1/16" Thick	Rect Raised Port	1.86W x 2.83H	127		
396-454 Gen IV	6.5-7.4	8	1965-90	1/8" Thick	Rect Raised Port	1.86W x 2.83H	128		
396-454 Gen IV	6.5-7.4	8	1965-90	1/16" Thick	Pontiac Super Duty, Brodix Big Duke	1.78W x 2.45H, Spread Port	510		
396-454 Gen IV	6.5-7.4	8	1965-90	1/8" Thick	Pontiac Super Duty, Brodix Big Duke	1.78W x 2.45H, Spread Port	511		

Note: Intake gaskets listed above fit aftermarket intake manifolds without upper mounting bolt holes.
*These Ultra-Seal gaskets are made of material with anti-stick graphite coating and does not have silicone bead around each port.

EXHAUST GASKET SPECIFICATIONS AND MODIFIED PORT APPLICATIONS

Chevrolet Big Block V-8

ENGINE CID	ENGINE LITERS	CYL.	YEARS	DESCRIPTION	PORT DIMENSIONS	MR. GASKET	ULTRA SEAL	COPPER SEAL
396-502	6.5-8.2	8	1965-99	Square Port, Stock Cast Iron Heads Gen IV, V, VI, Most Brodix, Dart, World Products Heads	1.85W x 1.90H	153	5910	7158
396-454	6.5-7.4	8	1965-90	Round Port, Cast Iron/Aluminum	1.92 Dia.	152	5911	7157
396-454	6.5-7.4	8	1965-90	Round Port, Large Race	2.15 Dia.	152A	5912	
396-454	6.5-7.4	8	1965-90	Square Port, Large Race	2.09W x 2.09H	154	5913	
396-454	6.5-7.4	8	N.A.	Round Port, Chevrolet, Pontiac, Oldsmobile, 4.840" Bore Center W/BB Chev. Bolt Pattern	2.40 Dia.		5914	
500	8.2	8	N.A.	Round Port, Chevrolet, Oldsmobile, 4.900" Bore Center	2.40 Dia.		5948	
500-700	8.2-11.5	8	N.A.	Round Port, GM 5.00" Bore Center W/BB Chev Bolt Pattern	2.40 Dia.		5947	

VALVE COVER GASKET APPLICATIONS AND SPECIFICATIONS

Chevrolet Big Block V-8

STOCK AND PERFORMANCE CYLINDER HEADS								
CONVENTIONAL PORT AND BOLT HOLE LOCATIONS								
ENGINE CID	ENGINE LITERS	CYL.	YEARS	DESCRIPTION	MR. GASKET	ULTRA SEAL		
396, 454 Gen IV	6.5-7.4	8	1965-90	3/16" Thick w/Locating Tabs	177 5854G ⁽³⁹⁾	5862		
396, 454 Gen IV	6.5-7.4	8	1965-90	5/16" Extra Thick w/o Locating Tabs	5371			
396, 454 Gen IV	6.5-7.4	8	1965-90	5/16" Extra Thick w/Locating Tabs	182	5863		
396, 454 Gen IV	6.5-7.4	8	1965-90	1/4" Thick with Steel Core, Laminated	5856			

⁽³⁹⁾ Molded Rubber

PERFORMANCE CYLINDER HEADS								
NON-CONVENTIONAL PORT AND BOLT HOLE LOCATIONS								
ENGINE CID	ENGINE LITERS	CYL.	YEARS	DESCRIPTION	MR. GASKET			
396, 454 Gen IV	6.5-7.4	8	1965-90	1/16" Thick with Steel Core, Fits Dart Big Chief, Pontiac Super Duty, Brodix Big Duke, 8 Bolt	577			
396, 454 Gen IV	6.5-7.4	8	1965-90	1/4" Thick with Steel Core, Fits Dart Big Chief, Pontiac Super Duty, Brodix Big Duke, 8 Bolt	5872			

GASKETS

Buick V-6 & V-8

ENGINE CID	ENGINE LITERS	CYL.	YEARS	INTAKE SET MR. GASKET	EXHAUST SET		VALVE COVER SET	WATER OUTLET
					MR. GASKET	ULTRA SEAL		
196	3.2	6	1978-79	604	652G		676	741 ⁽³⁷⁾
225	3.7	6	1964-67	604	652G		676	741 ⁽³⁷⁾
231	3.8	6	1975-78	604	652G		676	741 ⁽³⁷⁾
231	3.8	6	1979-86	606G	653G	5955	676	741 ⁽³⁷⁾
252	4.1	6	1980-85	606G	653G	5955	676	741 ⁽³⁷⁾
400, 430, 455	6.6 - 7.4	8	1967-71		651G	7530		
400, 430, 455	6.6 - 7.4	8	1972-76		651G	7530		

⁽³⁷⁾ bulk each

CYLINDER HEAD GASKET APPLICATIONS AND SPECIFICATIONS

Buick V-6

Ultra-Seal Head Gaskets							
ENGINE CID	ENGINE LITERS	CYL.	YEARS	DESCRIPTION	GASKET BORE	COMPRESSED THICKNESS	PART NO.
181, 196, 231, 252	3.0-4.1	6	1975-88	Flexible Graphite Core, Elastomer Coated	4.060"	.038"	5811
Note: Most head gaskets are packaged 2 per set, astrisk (*) designates individually packaged.							
Solicor Head Gaskets							
ENGINE CID	ENGINE LITERS	CYL.	YEARS	DESCRIPTION	GASKET BORE	COMPRESSED THICKNESS	PART NO.
181, 196, 231, 252	3.0-4.1	6	1975-88	Solid Steel Core, Steel Wire Ring Encased In Stainless Steel Combustion Flange	4.090"	.042"	5721
Note: Most head gaskets are packaged 2 per set, astrisk (*) designates individually packaged.							

PERFORMANCE OVERHAUL GASKET KITS				
Buick V-6				
ENGINE CID	ENGINE LITERS	CYL	YEARS	OVERHAUL KITS ULTRA SEAL
231	3.8	6	1978-85	5982

EXHAUST GASKET SPECIFICATIONS AND MODIFIED PORT APPLICATIONS

Buick V-6, V-8

ENGINE CID	ENGINE LITERS	CYL.	YEARS	DESCRIPTION	PORT DIMENSIONS	MR. GASKET	ULTRA SEAL
196, 225, 231	3.2-3.8	6	1964-78	Stock Port	1.06W x 1.66H	652G	
231, 252	3.8-4.1	6	1979-86	Stock Port	1.06W x 1.39H	653G	
231, 252	3.8-4.1	6	1979-86	Stage 2 Head	1.37W x 1.53H		5956
400, 430, 455	6.6-7.4	8	1967-76	Stock Port	1.24W x 1.86H	651G	7530
302-400	5.0-6.6	8	N.A.	Corporate Head	1.51W x 1.35H		5957



4362▲

ENGINE PORT POLISHING KIT

Mr. Gasket's Port Polishing Kit is designed for use on cast iron and aluminum components. This kit allows you to do your own detailed porting, polishing, and removal of flashing on all engine parts with the use of an electric drill. The kit contains (1) tapered cutting stone, (1) 1" diameter mini grind-flex flat wheel, (29) grind-polishing rolls (assorted sizes), and (3) various length mandrels.

Engine Port Polishing Kit4362



3795G▲

ENGINE OIL PRIMER

Priming the engine is an important precautionary measure that should be taken before you start the engine for the first time. Engineered to fit into the distributor aperture and operate with an electric hand drill, the engine oil primer pressurizes the oil system, assuring the lubrication of vital bearing surfaces.

All Chevrolet V-8 and 6 cyl., Pontiac V-83795G

GASKETS

Oldsmobile V-8

ENGINE CID	ENGINE LITERS	CYL	YEARS	INTAKE SET		EXHAUST SET		
				MR. GASKET	ULTRA SEAL	MR. GASKET	ULTRA SEAL	
330	5.4	8	1964-67	405G ⁽⁴⁰⁾	*5845 ⁽⁴⁰⁾	453	5945	1
350 ⁽²⁰⁾	5.7	8	1968-76	405G ⁽⁴⁰⁾	*5845 ⁽⁴⁰⁾	453	5945	2
400	6.6	8	1965-69	404 ⁽⁴⁰⁾	*5846 ⁽⁴⁰⁾	453	5945	3
425	7.0	8	1965-67	404 ⁽⁴⁰⁾	*5846 ⁽⁴⁰⁾	453	5945	4
455	7.4	8	1968-76	404 ⁽⁴⁰⁾	*5846 ⁽⁴⁰⁾	453	5945	5

⁽²⁰⁾ except Omega 1975-76 ⁽³⁷⁾ bulk each ⁽⁴⁰⁾ side gaskets only; metal valley pan not included * These Ultra-Seal gaskets are made of a new material that is less compressible, has an anti-stick graphite coating, and do not have the silicone bead around the ports.

CYLINDER HEAD GASKET APPLICATIONS

Oldsmobile V-8

Ultra-Seal Head Gaskets							
ENGINE CID	ENGINE LITERS	CYL.	YEARS	DESCRIPTION	GASKET BORE	COMPRESSED THICKNESS	PART NO.
330-455	5.4-7.4	8	1964-80	Flexible Graphite Core, Elastomer Coated	4.230"	.038"	5788
Note: Most head gaskets are packaged 2 per set, astrisk (*) designates individually packaged.							
MLS (MULTI-LAYERED STEEL) Head Gaskets							
ENGINE CID	ENGINE LITERS	CYL.	YEARS	DESCRIPTION	GASKET BORE	COMPRESSED THICKNESS	PART NO.
500	8.2	8	N/A	Nitrile Coated Outer Layers - Embossed, W/Steel Inner Spacer, DRCE 4.900" Bore Center	4.700"	.054"	3160G *
500	8.2	8	N/A	Nitrile Coated Outer Layers - Embossed, W/Steel Inner Spacer, DRCE 4.900" Bore Center	4.780"	.054"	3161G *
Note: Most head gaskets are packaged 2 per set, astrisk (*) designates individually packaged.							

INTAKE GASKET SPECIFICATIONS AND MODIFIED PORT APPLICATIONS

Oldsmobile V-8

STOCK AND PERFORMANCE CYLINDER HEADS								
CONVENTIONAL PORT AND BOLT HOLE LOCATIONS								
ENGINE CID	ENGINE LITERS	CYL.	YEARS	DESCRIPTION	APPLICATION	PORT DIMENSIONS	INTAKE SET	
							MR. GASKET	ULTRA SEAL
330-350, 403	5.4-6.6	8	1964-80	1/16" Thick	Stock Port	1.38W x 2.03H	405G ⁽⁴⁰⁾	*5845 ⁽⁴⁰⁾
400-455	6.6-7.4	8	1965-76	1/16" Thick	Stock Port	1.41W x 2.49H	404 ⁽⁴⁰⁾	*5846 ⁽⁴⁰⁾
⁽⁴⁰⁾ side gaskets only; metal valley pan not included								
PERFORMANCE CYLINDER HEADS								
NON-CONVENTIONAL PORT AND BOLT HOLE LOCATIONS								
ENGINE CID	ENGINE LITERS	CYL.	YEARS	DESCRIPTION	APPLICATION	PORT DIMENSIONS	INTAKE SET MR. GASKET	
500	8.2	8	N/A	1/16" Thick	DRCE 4.900" B.C.	1.83 W x 2.42H	406	
500	8.2	8	N/A	1/8" Thick	DRCE 4.900" B.C.	1.83 W x 2.42H	407	

Oldsmobile V-8

	VALVE COVER SET		OIL PAN SET	OVERHAUL	REAR MAIN SEAL	TIMING COVER SEAL	WATER OUTLET
	MR. GASKET	ULTRA SEAL					
1	476	5875	490			783G	743 (37)
2	476	5875	490			783G	743 (37)
3	476	5875	490	1417	1965	783G	743 (37)
4	476	5875	490	1417	1965	783G	743 (37)
5	476	5875	490	1417	1965	783G	743 (37)

EXHAUST GASKET APPLICATIONS

Oldsmobile V-8

ENGINE CID	ENGINE LITERS	CYL.	YEARS	DESCRIPTION	PORT DIMENSIONS	MR. GASKET	ULTRA SEAL	COPPER SEAL
330-455	5.4-7.4	8	1964-80	Rectangle Port	1.55w x 1.92h	453	5945	7170
500	8.2	8	N.A.	Pro Stock Oldsmobile DRCE 4.900" Bore Center, Round Port	2.40 Dia		5948	

VALVE COVER GASKET APPLICATIONS AND SPECIFICATIONS

Oldsmobile V-8

STOCK AND PERFORMANCE CYLINDER HEADS								
CONVENTIONAL PORT AND BOLT HOLE LOCATIONS								
ENGINE CID	ENGINE LITERS	CYL.	YEARS	DESCRIPTION	MR. GASKET	ULTRA SEAL		
330, 455	5.4-7.4	8	1964-80	3/16" Thick w/Locating Tabs	476	5875		

PERFORMANCE CYLINDER HEADS								
NON-CONVENTIONAL PORT AND BOLT HOLE LOCATIONS								
ENGINE CID	ENGINE LITERS	CYL.	YEARS	DESCRIPTION	MR. GASKET			
500	8.2	8	N/A	Pro Stock, 1/8" Thick, Fits DRCE Head	477			
500	8.2	8	N/A	Pro Stock, 1/4" Thick with Steel Core, Fits DRCE Head	5874			
500	8.2	8	N/A	Pro Stock, 1/8" Thick, Fits DRCE 96 Head	478			

OIL PAN GASKET APPLICATIONS AND SPECIFICATIONS								
ENGINE CID	ENGINE LITERS	CYL.	YEARS	DESCRIPTION	MR. GASKET			
330, 455	5.4-7.4	8	1964-80	Fits O.E. Block	490			
500	8.2	8	N/A	Pro Stock, Fits DRCED 4.900" Bore Center	492			

Pontiac V-8

ENGINE CID	ENGINE LITERS	CYL.	YEARS	INTAKE SET		EXHAUST SET		VALVE COVER SET		
				MR. GASKET	ULTRA SEAL	MR. GASKET	ULTRA SEAL	MR. GASKET	ULTRA SEAL	
326	5.3	8	1965-67	502G	5848	550G	5921	576	5869	1
350	5.7	8	1968-71	502G	5848	550G	5921	576	5869	2
350, 400	5.7-6.6	8	1972-79			550G	5921	576	5869	3
305, 350	5.0-5.7	8	1980-84	101B	5820	150A	5901	175	5860	4
305, 350 W/FI (5)	5.0-5.7	8	1985		5851 Full Set (7)	150A	5901	175	5860	5
305, 350 W/FI (5)	5.0-5.7	8	1986		5851 Full Set (7)	150A	5901	175	5860	6
305, 350 W/FI (5)	5.0-5.7	8	1987-91		5851 Full Set (7)	150A	5901	168 ⁽¹²⁾	5867 ⁽¹²⁾	7
350 LT1	5.7	8	1992-96	135G			5965	168 ⁽¹²⁾	5867 ⁽¹²⁾	8
389, 400 Ex. Ram Air	6.5-6.6	8	1965-71	502G	5848	550G	5921	576	5869	9
400 Ram Air III	6.6	8	1967-71	503G		550G	5921	576	5869	10
421, 428, 455 Ex. Ram Air	7.0-7.4	8	1965-71	502G	5848	550G	5921	576	5869	11

(2) cork/rubber material (4) oil pan gaskets fit 1965-71 only (5) tuned port injection (6) does not include #145 upper runner set

(7) includes upper runner set for T.P.I. (12) for center hold down valve covers (22) use #784G front cover seal (37) bulk each

(38) individually packaged (41) aluminum carrier-molded rubber insert

Pontiac V-8

	OIL PAN SET						
	MR. GASKET	ULTRA SEAL	CAM CHANGE KIT	REAR MAIN SEAL	TIMING COVER SEAL	TIMING COVER	WATER OUTLET
1	590 (4)	5889 (4)	4422 (4)		784G		742 (37)
2	590 (4)	5889 (4)	4422 (4)		784G		742 (37)
3					784G		742 (37)
4	185 (2)	5882 6560 (39)	4408 (6)	1960 (9) 1961 (10)	18	90 93	740 (37) 740C (38) 738G (41)
5	185 (2)	5882 6560 (39)	4408 (6)	1960 (9) 1961 (10)	18	90 93	740 (37) 740C (38) 738G (41)
6	185 (2)	5882 6560 (39)	4408 (6)	29	18	90 93	740 (37) 740C (38) 738G (41)
7	199 (2)	5885 6561 (39)	4407 (6)	29	18	90 93	740 (37) 740C (38) 738G (41)
8	199 (2)	5885 6561 (39)		29	18		
9	590 (4)	5889 (4)	4422 (4)		784G		742 (37)
10	590 (4)	5889 (4)	4422 (4)		784G		742 (37)
11	590 (4)	5889 (4)	4422 (4)		784G		742 (37)

See pages 154 for Modified Port applications
See pages 154 for Head Gasket applications

PERFORMANCE OVERHAUL GASKET KITS				
Pontiac V-8				
ENGINE CID	ENGINE LITERS	CYL	YEARS	OVERHAUL KIT ULTRA SEAL
326-455	5.4-7.4	8	1965-71	5997
Note: Overhul kit does not include valley pan cover gasket				

GASKETS

CYLINDER HEAD GASKET APPLICATIONS

Pontiac I-4, V-8

Ultra-Seal Head Gaskets							
ENGINE CID	ENGINE LITERS	CYL.	YEARS	DESCRIPTION	GASKET BORE	COMPRESSED THICKNESS	PART NO.
151	2.5	4	1979-83	Flexible Graphite Core, Elastomer Coated	4.140"	.038"	5781
326, 389, 400, 421, 428, 455	5.4-7.4	8	1965-76	Flexible Graphite Core, Elastomer Coated	4.250"	.038"	5810

Note: See Chevrolet listing for other 1976-91 305-350 gaskets

INTAKE GASKET SPECIFICATIONS AND MODIFIED PORT APPLICATIONS

Pontiac V-8

STOCK AND PERFORMANCE CYLINDER HEADS								
CONVENTIONAL PORT AND BOLT HOLE LOCATIONS								
ENGINE CID	ENGINE LITERS	CYL.	YEARS	DESCRIPTION	APPLICATION	PORT DIMENSIONS	INTAKE SET	
							MR. GASKET	ULTRA SEAL
326-455	5.4-7.4	8	65-71	1/16" Thick	Stock port	1.14" x 2.06"	502G	5848
400 Ram Air	6.6	8	67-71	1/16" Thick	Stock port	1.18" x 2.20"	503G	

Note: See Chevrolet listing for other 1976-91 305-350 gaskets

EXHAUST GASKET SPECIFICATIONS AND MODIFIED PORT APPLICATIONS

Pontiac V-8

ENGINE CID	ENGINE LITERS	CYL.	YEARS	DESCRIPTION	PORT DIMENSIONS	MR. GASKET	ULTRA SEAL	COPPER SEAL
326-455	5.4-7.4	8	1965-76	Open Center Port	1.46W x 1.93H	550A	5920	
326-455	5.4-7.4	8	1965-76	All D Port Including Ram Air III	1.50W x 1.94H	550G	5921	7171
400-455	5.4-7.4	8	1968-70	Ram Air IV	1.88 Dia Round Port	551	7523	
400-455	5.4-7.4	8	1971-72	455 High Output	1.88 Dia Round Port	551	7523	
400-455	5.4-7.4	8	1973-74	455 Super Duty	1.88 Dia Round Port	551	7523	
400	6.6	8	N.A.	Ram Air V	1.90W x 2.40H	552	5922	

VALVE COVER GASKET APPLICATIONS AND SPECIFICATIONS

Pontiac V-8

STOCK AND PERFORMANCE CYLINDER HEADS						
CONVENTIONAL PORT AND BOLT HOLE LOCATIONS						
ENGINE CID	ENGINE LITERS	CYL.	YEARS	DESCRIPTION	MR. GASKET	ULTRA SEAL
326, 455	5.3-7.4	8	1964-76	3/16" Thick w/Locating Tabs	576	5869
305, 350	5.0-5.7	8	1977-85	3/16" Thick w/Locating Tabs	175	5860
305, 350	5.0-5.7	8	1986-96	Center Bolt Design, 3/16" Thick	168	5867

PERFORMANCE CYLINDER HEADS						
NON-CONVENTIONAL MOUNTING BOLT HOLE LOCATIONS						
ENGINE CID	ENGINE LITERS	CYL.	YEARS	DESCRIPTION	MR. GASKET	
396, 454 Gen IV	6.5-7.4	8	1965-90	1/16" Thick with Steel Core, Fits Dart Big Chief, Pontiac Super Duty, Brodix Big Duke, 8 Bolt	577	
396, 454 Gen IV	6.5-7.4	8	1965-90	1/4" Thick with Steel Core, Fits Dart Big Chief, Pontiac Super Duty, Brodix Big Duke, 8 Bolt	5872	
500	8.2	8	N/A	Pro Stock, 1/8" Thick, Fits DRCE Head	477	
500	8.2	8	N/A	Pro Stock, 1/4" Thick with Steel Core, Fits DRCE Head	5874	
500	8.2	8	N/A	Pro Stock, 1/8" Thick, Fits DRCE 96 Head	478	



4327▲

FENDER COVER

Protect the paint on your fender from grease, scratches and nicks with Mr. Gasket's Fender Cover. This attractive vinyl cover features a non-slip back and seams, which forms a natural "pocket" that prevents tools from rolling off. Black with logos.

Fender Cover.....4327



4362▲

ENGINE PORT POLISHING KIT

Mr. Gasket's Port Polishing Kit is designed for use on cast iron and aluminum components. This kit allows you to do your own detailed porting, polishing, and removal of flashing on all engine parts with the use of an electric drill. The kit contains (1) tapered cutting stone, (1) 1" diameter mini grind-flex flat wheel, (29) grind-polishing rolls (assorted sizes), and (3) various length mandrels.

Engine Port Polishing Kit.....4362

GASKETS

Chrysler I-6 & V-8

ENGINE CID	ENGINE LITERS	CYL.	YEARS	INTAKE SET		EXHAUST SET		VALVE COVER SET		
				MR. GASKET	ULTRA SEAL	MR. GASKET	ULTRA SEAL	MR. GASKET	ULTRA SEAL	
225	3.7	6	1960-83	Intake & Exhaust 320G						1
318	5.2	8	1967-74	306G	5840	353	5938	379	5876	2
318	5.2	8	1975-91	306G	5840 ⁽²⁶⁾	353	5935	379	5876	3
340, 360	5.6-5.9	8	1968-89	307G	5840 ⁽²⁶⁾	353	5935	379	5876	4
392 Hemi	6.4	8	1957-58	310G		350G	7592	375G		5
383, 400, 413	6.3-6.8	8	1959-78	301	*5841 ⁽⁴⁰⁾	351	5936	378	5877 ⁽²³⁾	6
426 Wedge	7.0	8	1963-65	301	*5841 ⁽⁴⁰⁾	351	5936	378	5877 ⁽²³⁾	7
426 Hemi	7.0	8	1964-71	303G		352A	5937	374		8
440	7.2	8	1966-78	301	*5841 ⁽⁴⁰⁾	351	5936	378	5877 ⁽²³⁾	9

* These Ultra-Seal gaskets are made of a new material that is less compressible, has an anti-stick graphite coating, and do not have the silicone bead around the ports.
 (2) cork/rubber material (23) fits 6-bolt valve cover (24) 1958-74 (25) 1975-81 (26) 1975-81 4 bbl only
 (28) 360 only (40) side gaskets only; metal valley pan not included (41) composition material



3795G▲



7808▲

ENGINE OIL PRIMER

Priming the engine is an important precautionary measure that should be taken before you start the engine for the first time. Engineered to fit into the distributor aperture and operate with an electric hand drill, the engine oil primer pressurizes the oil system, assuring the lubrication of vital bearing surfaces.

All Chevrolet V-8 and 6 cyl., Pontiac V-8**3795G**

BLUE RTV SILICONE SEALER

The original blue. Makes reliable "formed-in-place" gaskets. Resists cracking, shrinking and migrating. Coats pre-cut gaskets to increase reliability. Temperature range -65°F to 500°F intermittent; resists auto and shop fluids.

Application includes valve covers, oil pans, intake manifold end seals, timing covers, water pumps, thermostat housings.

Blue RTV Silicone Sealer 3 oz. tube**7808**

	OIL PAN SET							
	MR. GASKET	ULTRA SEAL	CAM CHANGE KIT	REAR MAIN SEAL	TIMING COVER SEAL	TIMING COVER	WATER OUTLET	
1								
2	394 ⁽²⁾	5895		33	781G	790	744 ⁽²⁴⁾ 745 ⁽²⁵⁾	
3	394 ⁽²⁾	5895		33	781G	790	744 ⁽²⁴⁾ 745 ⁽²⁵⁾	
4	394 ⁽²⁾	5895	4424	32	781G	790	744 ⁽²⁴⁾ 745 ⁽²⁵⁾	
5						796G	744 ⁽²⁴⁾ 745 ⁽²⁵⁾	
6	397 ⁽⁴¹⁾ 391 ⁽²⁾			1968	781G	91	744 ⁽²⁴⁾ 745 ⁽²⁵⁾	
7	397 ⁽⁴¹⁾ 391 ⁽²⁾			1968	781G	91	744 ⁽²⁴⁾ 745 ⁽²⁵⁾	
8	397 ⁽⁴¹⁾ 391 ⁽²⁾			1968	781G	91	744 ⁽²⁴⁾ 745 ⁽²⁵⁾	
9	397 ⁽⁴¹⁾ 391 ⁽²⁾			1968	781G	91	744 ⁽²⁴⁾ 745 ⁽²⁵⁾	

See pages 160-161 for Modified Port applications
See pages 158-159 for Head Gasket applications



4327▲

FENDER COVER

Protect the paint on your fender from grease, scratches and nicks with Mr. Gasket's Fender Cover. This attractive vinyl cover features a non-slip back and seams, which forms a natural "pocket" that prevents tools from rolling off. Black with logos.

Fender Cover.....4327



4362▲

ENGINE PORT POLISHING KIT

Mr. Gasket's Port Polishing Kit is designed for use on cast iron and aluminum components. This kit allows you to do your own detailed porting, polishing, and removal of flashing on all engine parts with the use of an electric drill. The kit contains (1) tapered cutting stone, (1) 1" diameter mini grind-flex flat wheel, (29) grind-polishing rolls (assorted sizes), and (3) various length mandrels.

Engine Port Polishing Kit.....4362

GASKETS

CYLINDER HEAD GASKET APPLICATIONS

Chrysler V-8

Mr. Gasket Head Gaskets							
ENGINE CID	ENGINE LITERS	CYL.	YEARS	DESCRIPTION	GASKET BORE	COMPRESSED THICKNESS	PART NO.
273-360	4.5-5.9	8	67-89	Flexible Graphite Core, Elastomer Coated	4.140"	.028"	1121
361-440 Wedge	6.5-7.5	8	59-78	Steel Shim - Embossed	4.400"	.020"	1135
426 Hemi	6.5-7.5	8	66-71	Copper (Dead Soft)	4.335"	.043"	5364 ⁽⁴⁵⁾
426 Hemi	6.5-7.5	8	66-71	Copper (Dead Soft)	4.335"	.060"	5365 ⁽⁴⁵⁾
⁽⁴⁵⁾ o-rings are recommended to seal combustion pressure, high temp RTV silicone sealer is recommended to seal coolant ports in copper head gaskets.							
Ultra-Seal Head Gaskets							
ENGINE CID	ENGINE LITERS	CYL.	YEARS	DESCRIPTION	GASKET BORE	COMPRESSED THICKNESS	PART NO.
273-360	4.5-5.9	8	67-89	Flexible Graphite Core, Elastomer Coated	4.140"	.038"	5805
361-440 Wedge	5.9-7.2	8	59-78	Flexible Graphite Core, Elastomer Coated	4.450"	.038"	5784
Solicor Head Gaskets							
ENGINE CID	ENGINE LITERS	CYL.	YEARS	DESCRIPTION	GASKET BORE	COMPRESSED THICKNESS	PART NO.
273-360	4.5-5.9	8	67-89	Solid Steel Core, Steel Wire Ring Encased In Stainless Steel Combustion Flange	4.180"	.042"	5745
500	8.2	8	N/A	Pro Stock B1 "TS". Solid Steel Core, Steel Wire Ring Encased In Stainless Steel Combustion Flange	4.620"	.051"	5732
MLS (Muti-Layered Steel) Head Gaskets							
ENGINE CID	ENGINE LITERS	CYL.	YEARS	DESCRIPTION	GASKET BORE	COMPRESSED THICKNESS	PART NO.
340-360	5.6-5.9	8	68-89	Nitrile Coated Outer Layers - Embossed, W/Steel Inner Spacer	4.060"	.040"	3210G *
340-360	5.6-5.9	8	68-89	Nitrile Coated Outer Layers - Embossed, W/Steel Inner Spacer	4.125"	.040"	3211G *
340-360	5.6-5.9	8	68-89	Nitrile Coated Outer Layers - Embossed, W/Steel Inner Spacer	4.180"	.040"	3212G *
361-440 Wedge	5.6-5.9	8	59-78	Nitrile Coated Outer Layers - Embossed, W/Steel Inner Spacer	4.250"	.040"	3215G *
361-440 Wedge	5.6-5.9	8	59-78	Nitrile Coated Outer Layers - Embossed, W/Steel W/Steel Inner Spacer	4.350"	.040"	3216G *
361-440 Wedge	5.6-5.9	8	59-78	Nitrile Coated Outer Layers - Embossed, W/Steel Inner Spacer	4.375"	.040"	3217G *
361-440 Wedge	5.6-5.9	8	59-78	Nitrile Coated Outer Layers - Embossed, W/Steel Inner Spacer	4.410"	.040"	3218G *
440	7.2	8	N/A	Fits Mopar Performance Block P4876169. Nitrile Coated Outer Layers - Embossed, W/Steel Inner Spacer	4.500"	.040"	3233G *

Note: Most head gaskets are packaged 2 per set, astrisk (*) designates individually packaged.

CYLINDER HEAD GASKET APPLICATIONS (Continued)

Chrysler V-8

MLS (Multi-Layered Steel) Head Gaskets (Continued)							
ENGINE CID	ENGINE LITERS	CYL.	YEARS	DESCRIPTION	GASKET BORE	COMPRESSED THICKNESS	PART NO.
426 Hemi	7.0	8	66-71	Nitrile Coated Outer Layers - Embossed, W/Steel Inner Spacer	4.280"	.040"	3222G *
426 Hemi	7.0	8	66-71	Nitrile Coated Outer Layers - Embossed, W/Steel Inner Spacer	4.310"	.040"	3223G *
426 Hemi	7.0	8	N/A	Fits Mopar Performance Block P4529850/P5249804. Nitrile Coated Outer Layers - Embossed, W/Steel Inner Spacer	4.375"	.040"	3226G *
426 Hemi	7.0	8	N/A	Fits Mopar Performance Block P4529850/P5249804. Nitrile Coated Outer Layers - Embossed, W/Steel Inner Spacer	4.560"	.040"	3227G *
500 Hemi	8.2	8	N/A	Nitrile Coated Outer Layers - Embossed, W/Steel Inner Spacer (4.900: Bore Center)	4.700"	.054"	3235G *
500 Hemi	8.2	8	N/A	Nitrile Coated Outer Layers - Embossed, W/Steel Inner Spacer (4.900: Bore Center)	4.730"	.054"	3236G *

Note: Most head gaskets are packaged 2 per set, astrisk (*) designates individually packaged.

PERFORMANCE OVERHAUL GASKET KITS				
Chrysler V-8				
ENGINE CID	ENGINE LITERS	CYL	YEARS	OVERHAUL KIT ULTRA SEAL
318	5.2	8	1975-91	5998
360	5.9	8	1971-91	5999

INTAKE GASKET SPECIFICATIONS AND MODIFIED PORT APPLICATIONS

Chrysler V-8

STOCK AND PERFORMANCE CYLINDER HEADS							
CONVENTIONAL PORT AND BOLT HOLE LOCATIONS							
ENGINE CID	ENGINE LITERS	CYL.	YEARS	DESCRIPTION	APPLICATION	PORT DIMENSIONS	INTAKE SET
							MR. GASKET
273-318	4.5-5.2	8	1966-89	1/16" Thick	2 BBL Stock Port	1.05W x 2.07H	306G
318	5.2	8	1967-89	1/16" Thick	4 BBL Stock Port	1.17W x 2.27H	307G
340-360	5.6-5.9	8	1968-89	1/16" Thick	Stock Port	1.17W x 2.27H	307G
318-360	5.2-5.9	8	1992 - 97	1/16" Thick	Stock Port	1.12W x 2.14H	308G
340-360	5.6-5.9	8	1968-89	1/16" Thick	W-2 Stock Port	1.43W x 2.05H	316
392 Hemi	6.4	8	1957-58	1/16" Thick	Stock Port	1.43W x 1.92H	310G

GASKETS

INTAKE GASKET SPECIFICATIONS AND MODIFIED PORT APPLICATIONS

Chrysler V-8,(Cont.)

STOCK AND PERFORMANCE CYLINDER HEADS (Cont.)							
CONVENTIONAL PORT AND BOLT HOLE LOCATIONS							
ENGINE CID	ENGINE LITERS	CYL.	YEARS	DESCRIPTION	APPLICATION	PORT DIMENSIONS	INTAKE SET
							MR. GASKET
361-440	5.9-7.2	8	1958-78	1/16" Thick	Stock Port	1.21W x 2.26H	301 ⁽⁴⁰⁾
413-426	6.8-7.0	8	1962-64	1/16" Thick	H.P. Wedge	1.40W x 2.72H	302
426 Hemi	7.0	8	1964-71	1/16" Thick	Stock Port	1.85W x 2.01H	303G
426 Hemi	7.0	8	1964-71	1/8" Thick	Stock Port	1.85W x 2.01H	311G
426 Hemi	7.0	8	1964-65	1/16" Thick	Veney Head	2.37 W x 2.42H	312
426 Hemi	7.0	8	1966-71	1/16" Thick	BAE Head	2.21 W x 2.35H	326

* These Ultra-Seal gaskets are made of a new material that is less compressible, has an anti-stick graphite coating, and do not have the silicone bead around the ports. ⁽⁴⁰⁾ side gaskets only; metal valley pan not included

PERFORMANCE CYLINDER HEADS							
NON-CONVENTIONAL PORT AND BOLT HOLE LOCATIONS							
ENGINE CID	ENGINE LITERS	CYL.	YEARS	DESCRIPTION	APPLICATION	PORT DIMENSIONS	INTAKE SET MR. GASKET
500 B1, TS	8.2	8	N/A	1/16" Thick	Pro Stock	1.40 W x 2.71H	330
500 Hemi 2000	8.2	8	N/A	1/16" Thick	Pro Stock	2.20 Dia.	331G
500 Hemi 2000	8.2	8	N/A	1/8" Thick	Pro Stock	2.20 Dia.	332
500 Hemi 2000	8.2	8	N/A	1/16" Thick	Pro Stock	No Ports	333G

EXHAUST GASKET SPECIFICATIONS AND MODIFIED PORT APPLICATIONS

Chrysler I-4, V-8 V-10

ENGINE CID	ENGINE LITERS	CYL.	YEARS	DESCRIPTION	PORT DIMENSIONS	MR. GASKET	ULTRA SEAL	COPPER SEAL
122	2.0	4	95-04	Stock Port, SOHC	2.11W x 1.35H			7235
122-148	2.0-2.4	4	95-00	Stock Port, DOHC	1.00W x 1.93H		7580	
273-318	4.5-5.2	8	67-74	Stock Port	1.00W x 1.64H	353	5938	7166
318-360	5.2-5.9	8	92-03	Stock Port	1.25W x 1.68H		5949	
318, 340, 360	5.2-5.9	8	75-91	Stock Port	1.30W x 1.80H	358	5935	
340-360	5.6-5.9	8	68-89	W-2 Head Stock Port	1.56W x 1.50H		5939	
345 Hemi	5.7	8	02-05	Stock Port	1.45W x 1.47H		7594	
331-392 Hemi	5.4-6.5	8	54-58	Stock Port	1.55W x 2.13H	350G	7592	
361-440 Exc. Hemi	5.9-7.2	8	59-78	Stock Port	1.78W x 1.48H	351	5936	7167
440	7.2	8	N/A	Indy Cyl. Head	1.71W x 2.08H		5944	
426 Hemi	7.0	8	64-71	Stock Port	1.85W x 1.89H	352A	5937	
488 Hemi	8.0	8	94-03	Stock Port	1.36W x 1.47H		7593	

EXHAUST GASKET SPECIFICATIONS AND MODIFIED PORT APPLICATIONS

Chrysler I-4, V-8 V-10 (Cont.)

PERFORMANCE CYLINDER HEADS NON-CONVENTIONAL PORT AND BOLT HOLE LOCATIONS							
ENGINE CID	ENGINE LITERS	CYL.	YEARS	DESCRIPTION	PORT DIMENSIONS	ULTRA SEAL	COPPER SEAL
PRO STOCK							
500 Hemi	8.2	8	N/A	Pro stock B1, TS	2.25" Dia.	7590	
500 Hemi	8.2	8	N/A	Pro Stock hemi 2000	2.27W x 2.02H	7591	
TOP FUEL & FUNNY CAR							
500 Hemi	8.2	8	N/A	D-Port, Stage 2 Head	2.03W x 2.10H	5940	
500 Hemi	8.2	8	N/A	Round Port, BAE Head	2.56" Dia.	5941	
500 Hemi	8.2	8	N/A	Oval Port, Veney Head	2.64W x 2.31H	5942	
500 Hemi	8.2	8	N/A	D-Port, BAE Head	2.54W x 2.05H	5943	
500 Hemi	8.2	8	N/A	BAE Competition Head	2.54W x 1.82H		7180

OIL PAN GASKET APPLICATIONS AND SPECIFICATIONS							
ENGINE CID	ENGINE LITERS	CYL.	YEARS	DESCRIPTION	APPLICATION	MR. GASKET	ULTRA SEAL
318-360	5.2-5.9	8	1967-89	1/16" Thick	OE Block	394	5895
392	6.4	8	1957-58	1/16" Thick	OE Block	392	
500 Hemi	8.2	8	N/A	1/16" Thick	Rodak/TFX 92 (Wide Rail)	387	
500 Hemi	8.2	8	N/A	1/16" Thick	Rodak/TFX 96 (Narrow Rail)	388	
426-500 Hemi	7.0-8.2	8	1964-71	1/16" Thick	Chrysler / K.B.	397	

VALVE COVER GASKET APPLICATIONS

Chrysler V-8

STOCK AND PERFORMANCE CYLINDER HEADS CONVENTIONAL MOUNTING BOLT HOLE LOCATIONS							
ENGINE CID	ENGINE LITERS	CYL.	YEARS	DESCRIPTION	MR. GASKET	ULTRA SEAL	
273-360	4.5-5.9	8	1964-91	3/16" Thick w/Locating Tabs	379	5876	
318-360	5.2-5.9	8	1992-01	3/16" Thick w/Locating Tabs	5866G ⁽³⁹⁾		
331-392 Hemi	5.4-6.4	8	1951-58	1/16" Thick w/o Locating Tabs	375G		
361-440 Wedge	5.9-7.2	8	1958-78	3/16" Thick w/o Locating Tabs, 6 Bolt Head	378	5877	
426 Hemi	7.0	8	1964-71	3/16" Thick w/o Locating Tabs	374		
426 Hemi	7.0	8	1964-71	1/16" Thick w/o Locating Tabs	380		
426 Hemi	7.0	8	1964-71	.100" Thick with Steel Core	384		

⁽³⁹⁾ Molded Rubber

PERFORMANCE CYLINDER HEADS NON-CONVENTIONAL MOUNTING BOLT HOLE LOCATIONS							
ENGINE CID	ENGINE LITERS	CYL.	YEARS	DESCRIPTION	MR. GASKET		
440	7.2	8	N/A	Indy Cyl. Head, 1/16" Thick	382		
500	8.2	8	N/A	B1, TS Head, 1/16" Thick	383		
426-500 Heim	7.0-8.2	8	N/A	Brad Anderson-Stage V, Ken Veney-Fat Head 10 Bolt Gasket, 1/16" thick	385		

GASKETS

Ford V-8

ENGINE CID	ENGINE LITERS	CYL.	YEARS	INTAKE SET		EXHAUST SET		VALVE COVER SET		
				MR. GASKET	ULTRA SEAL	MR. GASKET	ULTRA SEAL	MR. GASKET	ULTRA SEAL	
281 SOHC	4.6	8	1991-03		5852G* 1991-94		5727		5857 ⁽³⁹⁾ 1991-95	1
281 DOHC	4.6	8	1993-03		5852G* 1993-95		7556		5858G 1993-96	2
302 Boss	5.0	8	1969-70	209G		258	5932	274	5871	3
221, 260, 289, 302 Exc Boss	3.6-5.0	8	1962-76	203	5831	253	5930	276	5870	4
302	5.0	8	1977-85	223	5834	253	5930	276	5870	5
302 EFI	5.0	8	1986-95	148 ⁽³²⁾	5835	253	5930	276	5870	6
351 Windsor	5.7	8	1969-74	210	5832	253	5930	276	5870	7
351 Windsor	5.7	8	1975-92	223	5834	253	5930	276	5870	8
351 Cleveland 2 BBL.	5.7	8	1970-74	211	5837	263	5951	274	5871	9
351 Cleveland 4 BBL.	5.7	8	1970-74	214	5836	258	5932	274	5871	10
351M, 400	5.7	8	1975-82			263	5951	274	5871	11
332, 352, 360, 390	5.4-6.4	8	1958-65	201G		251	5952	275		12
390, 428	6.4-7.0	8	1966-71	206G		254G		275		13
406, 427,	6.6-7.0	8	1962-68	201G		252	5953	275		14
429, 460	7.0-7.5	8	1968-88		5838*	259G	5954	278		15

* These Ultra-Seal gaskets are made of a new material that is less compressible, has an anti-stick graphite coating, and do not have the silicone bead around the ports (32) top plenum gasket only (37) bulk each (38) individually packaged (39) molded rubber

	OIL PAN SET						
	MR. GASKET	ULTRA SEAL	CAM CHANGE KIT	REAR MAIN SEAL	TIMING COVER SEAL	TIMING COVER	WATER OUTLET
1	6684 ⁽³⁹⁾						
2	6684 ⁽³⁹⁾						
3	5890 6683 ⁽³⁹⁾	291		1966	780G	793G	746 ⁽³⁷⁾ 746C ⁽³⁸⁾
4	5890 6683 ⁽³⁹⁾	291	4410	1963	780G	792G	746 ⁽³⁷⁾ 746C ⁽³⁸⁾
5	5890 6683 ⁽³⁹⁾	291		1963 (1977-82) 30 (1983-85)	780G	792G	746 ⁽³⁷⁾ 746C ⁽³⁸⁾
6	5890 6683 ⁽³⁹⁾	291		30	780G	792G	746 ⁽³⁷⁾ 746C ⁽³⁸⁾
7	5891	294		1963	780G	792G	746 ⁽³⁷⁾ 746C ⁽³⁸⁾
8	5891	294		1963 (1975-82) 31 (1983-97)	780G	792G	746 ⁽³⁷⁾ 746C ⁽³⁸⁾
9	5992	293		1966	780G	793G	747 ⁽³⁷⁾
10	5892	293		1966	780G	793G	747 ⁽³⁷⁾
11	5892	293		1966	780G	793G	747 ⁽³⁷⁾
12		290		1964	780G	794G	748 ⁽³⁷⁾
13		290		1964	780G	794G	748 ⁽³⁷⁾
14		290		1964	780G	794G	748 ⁽³⁷⁾
15		292		1965	780G	795G	747 ⁽³⁷⁾

See pages 166-167 for Modified Port applications

See pages 164-165 for Head Gasket applications

GASKETS

CYLINDER HEAD GASKET APPLICATIONS AND SPECIFICATIONS

Ford I-4, I-6, V-8

Mr. Gasket Head Gaskets							
ENGINE CID	ENGINE LITERS	CYL.	YEARS	DESCRIPTION	GASKET BORE	COMPRESSED THICKNESS	PART NO.
332-428	6.5-7.5	8	1958-71	Steel Shim - Embossed	4.420"	.030"	1132
Note: Most head gaskets are packaged 2 per set, astrisk (*) designates individually packaged.							
Ultra-Seal Head Gaskets							
ENGINE CID	ENGINE LITERS	CYL.	YEARS	DESCRIPTION	GASKET BORE	COMPRESSED THICKNESS	PART NO.
240,300	3.9-4.98	6	1965-90	Flexible Graphite Core, Elastomer Coated	4.160"	.038"	5786*
281	4.6	8	1991-03	Flexible Graphite Core, Elastomer Coated Left Side	3.610"	.042"	5775*
281	4.6	8	1991-03	Flexible Graphite Core, Elastomer Coated Right Side	3.610"	.042"	5776*
260, 289 302, 351W.	5.9-7.2	8	1962-95	Flexible Graphite Core, Elastomer Coated	4.100"	.038"	5807
351C, 351M, 400	5.7-6.5	8	1970-79	Flexible Graphite Core, Elastomer Coated	4.400"	.038"	5808
390-428	6.4-7.0	8	2961-71	Flexible Graphite Core, Elastomer Coated	4.400"	.038"	5790
429, 460	7.0-7.5	8	1968-98	Flexible Graphite Core, Elastomer Coated	4.490"	.038"	5809
Note: Most head gaskets are packaged 2 per set, astrisk (*) designates individually packaged.							
Solicor Head Gaskets							
ENGINE CID	ENGINE LITERS	CYL.	YEARS	DESCRIPTION	GASKET BORE	COMPRESSED THICKNESS	PART NO.
260, 289, 302, 351W	5.9-7.2	8	1962-95	Solid Steel Core, Steel Wire Ring Encased In Stainless Steel Combustion Flange	4.100"	.042"	5751
302 Boss	5.7	8	1969-71	Solid Steel Core, Steel Wire Ring Encased In Stainless Steel Combustion Flange	4.100"	.042"	5755
351C, 351M, 400	5.7-6.5	8	1970-79	Solid Steel Core, Steel Wire Ring Encased In Stainless Steel Combustion Flange	4.08"	.044"	5757
390-428	6.4-7.0	8	1961-71	Solid Steel Core, Steel Wire Ring Encased In Stainless Steel Combustion Flange	4.400"	.042"	5760
429, 460	7.0-7.5	8	1968-98	Solid Steel Core, Steel Wire Ring Encased In Stainless Steel Combustion Flange	4.670"	.042"	5764
302, 351W SVO	5.0-5.7	8	N/A	Solid Steel Core, Steel Wire Ring Encased In Stainless Steel Combustion Flange, Left Side	4.160"	.042"	5758*
302, 351W SVO	5.0-5.7	8	N/A	Solid Steel Core, Steel Wire Ring Encased In Stainless Steel Combustion Flange, Right Side	4.160"	.042"	5759*
500	8.2	8	N/A	Solid Steel Core, Steel Wire Ring Encased In Stainless Steel Combustion Flange, 10 Bolt Pattern Hemi Block/Head.	4.670"	.051"	5768
500	8.2	8	N/A	Solid Steel Core, Steel Wire Ring Encased In Stainless Steel Combustion Flange, 18 Bolt Pattern Wedge Block/Head.	4.670"	.051"	5769
Note: Most head gaskets are packaged 2 per set, astrisk (*) designates individually packaged.							

CYLINDER HEAD GASKET APPLICATIONS AND SPECIFICATIONS

Ford I-4, I-6, V-8

MLS (Multi-Layered Steel) Head Gaskets							
ENGINE CID	ENGINE LITERS	CYL.	YEARS	DESCRIPTION	GASKET BORE	COMPRESSED THICKNESS	PART NO.
140	2.3	4	74-93	Nitrile Coated Outer Layers - Embossed, W/Steel Inner Spacer	3.830"	.040"	3180G *
302, 351W SVO	5.0-5.7	8	N/A	Nitrile Coated Outer Layers - Embossed, W/Steel Inner Spacer, Left Side	4.100"	.040"	3165G *
302, 351W SVO	5.0-5.7	8	N/A	Nitrile Coated Outer Layers - Embossed, W/Steel Inner Spacer, Right Side	4.100"	.040"	3166G *
302, 351W SVO	5.0-5.7	8	N/A	Nitrile Coated Outer Layers - Embossed, W/Steel Inner Spacer, Left Side	4.125"	.040"	3167G *
302, 351W SVO	5.0-5.7	8	N/A	Nitrile Coated Outer Layers - Embossed, W/Steel Inner Spacer, Right Side	4.125"	.040"	3168G *
302, 351W SVO	5.0-5.7	8	N/A	Nitrile Coated Outer Layers - Embossed, W/Steel Inner Spacer, Left Side	4.150"	.040"	3169G *
302, 351W SVO	5.0-5.7	8	N/A	Nitrile Coated Outer Layers - Embossed, W/Steel Inner Spacer, Right Side	4.150"	.040"	3170G *
302, 351W SVO	5.0-5.7	8	N/A	Nitrile Coated Outer Layers - Embossed, W/Steel Inner Spacer, Left Side	4.180"	.040"	3171G *
302, 351W SVO	5.0-5.7	8	N/A	Nitrile Coated Outer Layers - Embossed, W/Steel Inner Spacer, Right Side	4.180"	.040"	3172G *
302, 351W SVO	5.0-5.7	8	N/A	Nitrile Coated Outer Layers - Embossed, W/Steel Inner Spacer, Left Side	4.200"	.040"	3173G *
302, 351W SVO	5.0-5.7	8	N/A	Nitrile Coated Outer Layers - Embossed, W/Steel Inner Spacer, Right Side	4.200"	.040"	3174G *
289, 302 351W	5.0-5.7	8	1965-95	Nitrile Coated Outer Layers - Embossed, W/Steel Inner Spacer, Fits O.E. Block	4.030"	.040"	3175G *
289, 302 351W	5.0-5.7	8	1965-95	Nitrile Coated Outer Layers - Embossed, W/Steel Inner Spacer, Fits O.E. Block	4.100"	.040"	3176G *
289, 302 351W	5.0-5.7	8	1965-95	Nitrile Coated Outer Layers - Embossed, W/Steel Inner Spacer, Fits O.E. Block	4.200"	.040"	3177G *

Note: Most head gaskets are packaged 2 per set, asterisk (*) designates individually packaged.

PERFORMANCE OVERHAUL GASKET KITS

Ford V-8

ENGINE CID	ENGINE LITERS	CYL	YEARS	OVERHAUL KITS	
				ULTRA SEAL	SOLICOR
221, 260, 289, 302 Exc. Boss	3.6-5.0	8	1962-76	5983	6604G
302	5.0	8	1977-82	5984	
302	5.0	8	1983-95	5985	
351W	5.7	8	1969-74	5986	
351W	5.7	8	1975-82	5987	
351W	5.7	8	1983-97	5988	
351C 4 BBL	5.7	8	1970-74	5989	
429, 460 Exc. CJ, SCJ, Boss	7.0-7.5	8	1968-88	5990	

GASKETS

INTAKE GASKET SPECIFICATIONS AND MODIFIED PORT APPLICATIONS

Ford V-8

STOCK AND PERFORMANCE CYLINDER HEADS									
CONVENTIONAL PORT AND BOLT HOLE LOCATIONS									
ENGINE CID	ENGINE LITERS	CYL.	YEARS	DESCRIPTION	APPLICATION	PORT DIMENSIONS	INTAKE SET		ULTRA SEAL II
							MR. GASKET	ULTRA SEAL	
281 SOHC, DOHC	4.6	8	91-95	1/8" Thick	Stock Port	1.69W x 1.73H		5852G	
260, 289, 302 Factory HP	4.3-5.0	8	62-76	1/16" Thick	Stock Port	1.21W x 2.11H		5832	
260, 289, 302 Exc Factory HP	4.3-5.0	8	62-76	1/16" Thick	Stock Port	1.20W x 2.13H	203G	5831	
260, 289, 302 Exc Factory HP	4.3-5.0	8	62-76	1/8" Thick	Stock Port	1.20W x 2.13H	213		
302	5.0	8	77-85	1/16" Thick	Stock Port	1.25W x 2.11H	223	5834	825G
302EFI	5.0	8	86-95	1/16" Thick	Stock Port	1.25W x 2.11H	148	5835	826G
302, 351C, 351W, SVO	5.0-5.7	8	N/A	1/16" Thick	Stock Port	1.56W x 2.06H	204G		
302 Boss	5.0	8	69-71	1/16" Thick	Stock Port	1.86W x 2.60H	209G		
351W	5.7	8	69-76	1/16" Thick	Stock Port	1.21W x 2.11H	210	5832	
351W	5.7	8	77-97	1/16" Thick	Stock Port	1.21W x 2.11H	223	5834	
351C 2 BBL	5.7	8	70-74	1/16" Thick	Stock Port	1.62W x 2.28H	211	5837	
351C 4 BBL	5.7	8	70-74	1/16" Thick	Stock Port	1.83W x 2.66H	214	5836	
351C 4 BBL	5.7	8	70-74	1/8" Thick	Stock Port	1.83W x 2.66H	215		
351M, 400	5.7-6.5	8	75-82	1/16" Thick	Stock Port	1.53W x 2.16H	222		
332, 352, 360, 390	5.4-6.4	8	58-65	1/16" Thick	Stock Port	1.48W x 2.56H	201G		
390, 428	6.4-7.0	8	66-71	1/16" Thick	Stock Port	1.45W x 2.40H	206G		
406, 427	6.6-7.0	8	62-68	1/16" Thick	Stock Port	1.48W x 2.56H	201G		
427	7.0	8	62-68	1/16" Thick	Med Riser	1.40W x 2.20H	202A		
427	7.0	8	62-68	1/16" Thick	High Riser	1.50W x 2.90H	202G		
427	7.0	8	62-68	1/16" Thick	Tunnel Port	2.31W x 2.20H	205G		
429 CJ, SCJ	7.5	8	70-71	1/16" Thick	Stock Port	2.23W x 2.60H	208A	5839	
429 Boss Hemi	7.5	8	69-70	1/16" Thick	Stock Port	2.48 Dia.	207G		
429, 460	7.0-7.5	8	68-88	1/16" Thick	Stock Port	2.00W x 2.26H	208G	*5838	
429, 460 SVO	7.0-7.5	8	N/A	1/16" Thick	Stock Port	1.82W x 1.95H	228		
429, 460 SVO	7.0-7.5	8	N/A	1/8" Thick	Stock Port	1.82W x 1.95H	229		

*These Ultra-Seal gaskets are made of a new material that is less compressible, has an anti-stick graphite coating, and do not have the silicone bead around the ports.

EXHAUST GASKET SPECIFICATIONS AND MODIFIED PORT APPLICATIONS

Ford I-4, I-6, V-8, V-10

ENGINE CID	ENGINE LITERS	CYL.	YEARS	DESCRIPTION	PORT DIMENSIONS	MR. GASKET	ULTRA SEAL	COPPER SEAL
122	2.0	4	1971-74	Stock Port	1.16w x 1.55h	262G		
122	2.0	4	2001-Up	ZX3 DOHC Head	1.41w x 1.82h		7551	
140	2.3	4	1974-93	Stock Port	1.58 Dia.	265G		
144, 200, 250	2.3-4.1	6	1960-83	Stock Port	1.49w x 1.14h	266G		
240, 300	3.9-4.9	6	1965-87	Intake/Exhaust Port	1.55w x 1.78h	260		
281	4.6	8	1991-03	SOHC Stock Port	1.63 Dia.		5927	
281	4.6	8	1993-03	DOHC Stock Port	1.21w x 2.16h		7556	
281	4.6	8	2004-05	DOHC Stock Port	1.78 Dia.		7558	
260-351W	4.3-5.0	8	1962-86	Round Port	1.42 Dia.	253A		
260-351W	4.3-5.0	8	1962-95	Stock Port	1.04w x 1.31h	6460		
260-351W	4.3-5.0	8	1962-95	Small Race Port	1.12w x 1.48h	253	5930	7160
302-351W	4.3-5.0	8	1987-95	Oval Port	1.25w x 1.75h	264G	5928	7161
351C, 315M, 400	5.0-5.7	8	1970-74	2 BBL Stock Port	1.58w x 1.96h	263G	5951	
302 Boss, 351C	5.0-5.7	8	1969-74	4 BBL Stock Port	1.90w x 2.20h	258G	5932	
302	5.0	8	N/A	W.P. Windsor Jr. Dart	1.30w x 1.40h		5929	
302	5.0	8	N/A	SVO, Yates Head	1.49w x 1.58h		7565	
351C Boss	5.7	8	1970-74	High Port-Round	2.21 Dia.		5933	
332-390	5.4-6.4	8	1958-65	FE Stock Port, 8 Bolt	1.56w x 2.32h	251	5952	7164
390, 428	6.4-7.0	8	1966-71	FE Stock Port, 14 Bolt	1.38w x 2.12h	254G		
406, 427	6.6-7.0	8	1962-68	FE Stock Port, 16 Bolt	1.38w x 2.05h	252	5953	
428 Cobra Jet	7.0	8	1969-70	FE Stock Port, 16 Bolt	1.40w x 1.78h	257G		
429, 460	7.0-7.5	8	1968-88	Stock Port	1.25w x 2.08h	259G	5954	7165
429 Cobra Jet	7.0	8	1970-71	Stock Port	1.50w x 2.40h	259A		
429 Boss Hemi	7.0-7.5	8	1970	Stock Port	1.90w x 2.20h		5931	
460	7.5	8	N/A	SVO, Round Port	2.28 Dia.		5934	
460	7.5	8	N/A	SVO, Square Port	1.85w x 1.91h		5959	
412	6.8	10	1997-01	Stock Port	1.61 Dia.		7575	

FORD FUEL INJECTION GASKETS

Throttle body gasket kits for 65mm & 77mm throttle body kits consist of 4 gaskets: EGR spacer to intake manifold, throttle body to spacer, EGR valve gasket, and air valve gasket.

DESCRIPTION	PART NO.
65mm Throttle Body Kit	235
77mm Throttle Body Kit	236
Upper Runner Plenum Base To Manifold Gasket	
Stock Manifold	148
GT-40 Manifold	149

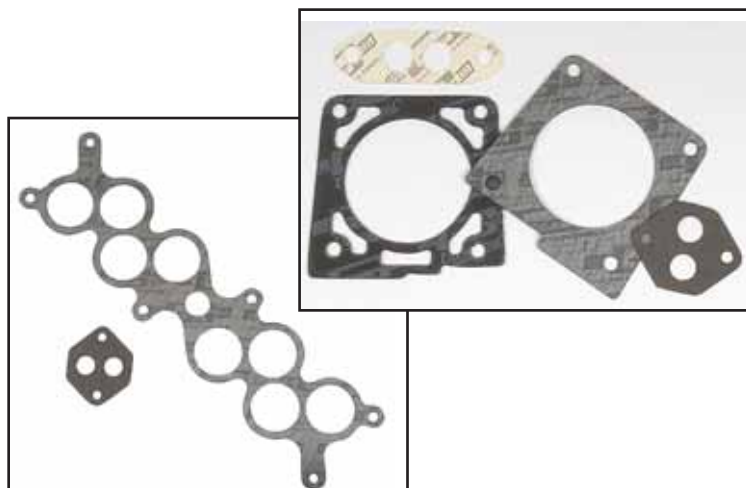

GASKETS

VALVE COVER GASKET APPLICATIONS AND SPECIFICATIONS

Ford V-8

STOCK AND PERFORMANCE CYLINDER HEADS						
CONVENTIONAL PORT AND BOLT HOLE LOCATIONS						
ENGINE CID	ENGINE LITERS	CYL.	YEARS	DESCRIPTION	MR. GASKET	ULTRA SEAL
221, 260, 289, 302, 351W Exc Boss	3.6-5.7	8	1962-97	3/16" Thick w/Locating Tabs	276, 5859G ⁽³⁹⁾	5870
281	4.6	8	1991-95	3/16" Thick w/o Locating Tabs	5857 ⁽³⁹⁾	
281	4.6	8	1993-96	3/16" Thick w/o Locating Tabs	5858G ⁽³⁹⁾	
302, 351W	5.0-5.7	8	1988-97	1/8" Thick, Steel Frame w/Neoprene Seal		5879
302 Boss, 351C/M, 400	5.0-6.5	8	1969-82	3/16" Thick w/Locating Tabs	274	5871
332, 352, 360, 390, 406, 427, 428	5.4-7.0	8	1958-76	3/16" Thick w/Locating Tabs	275	
429, 460	7.0-7.5	8	1968-88	3/16" Thick w/Locating Tabs	278	

⁽³⁹⁾ Molded Rubber

American Motors (AMC) V-8

ENGINE CID	ENGINE LITERS	CYL.	YEARS	INTAKE SET		EXHAUST SET		VALVE COVER SET	OIL PAN SET	WATER OUTLET
				MR. GASKET	ULTRA SEAL	MR. GASKET	ULTRA SEAL	MR. GASKET	MR. GASKET	
290	4.8	8	1966-69	800G	*5844	850		875	890	743 ⁽³⁷⁾
304	5.0	8	1970-79	800G	*5844	851	5950	875	890	743 ⁽³⁷⁾
343	5.6	8	1967-69	800G	*5844	850		875	890	743 ⁽³⁷⁾
360	5.9	8	1970-78	800G	*5844	851	5950	875	890	743 ⁽³⁷⁾
390	6.4	8	1968-69	800G	*5844	850		875	890	743 ⁽³⁷⁾
390	6.4	8	1970	800G	*5844	851	5950	875	890	743 ⁽³⁷⁾
401	6.6	8	1971-76	800G	*5844	851	5950	875	890	743 ⁽³⁷⁾

* These Ultra-Seal gaskets are made of a new material that is less compressible, has an anti-stick graphite coating, and do not have the silicone bead around the ports.
⁽³⁷⁾ bulk each

EXHAUST GASKET SPECIFICATIONS AND MODIFIED PORT APPLICATIONS

ENGINE CID	ENGINE LITERS	CYL.	YEARS	DESCRIPTION	PORT DIMENSIONS	MR. GASKET	ULTRA SEAL	COPPER SEAL
304, 360 390, 401	5.0-6.6	8	1970-79	Dog Leg Port	1.25" x 1.75"	851	5950	7174

Toyota I-4

EXHAUST GASKET SPECIFICATIONS AND MODIFIED PORT APPLICATION

ENGINE CID	ENGINE LITERS	CYL.	YEARS	DESCRIPTION	PORT DIMENSIONS	MR. GASKET
2189CC	2.2	4	1975-80	Stock Port	1.12" Dia	722G

SPORT COMPACT ENGINE GASKETS

CYLINDER HEAD GASKET APPLICATIONS AND SPECIFICATIONS

MLS (Muti-Layered Steel) Head Gaskets								
MAKE	ENGINE	ENGINE DESIGNATOR	CYL	YEAR	DESCRIPTION	GASKET BORE	COMPRESSED THICKNESS	PART NO.
Acura	1.8L	B18A1, B1 DOHC	4	1990-02	Nitrile Coated Outer Layers - Embossed, W/Steel Inner Spacer	82mm	.76mm	3189G
Acura	1.8L	B18A1, B1 DOHC	4	1990-02	Nitrile Coated Outer Layers - Embossed, W/Steel Inner Spacer	84mm	.76mm	3190G
Honda	1.5L	D15Z1 VTEC	4	1991-95	Nitrile Coated Outer Layers - Embossed, W/Steel Inner Spacer	75mm	.76mm	3185G
Honda	1.6L	B16Z6 VTEC, D16Y5,7,8 VTEC	4	1992-00	Nitrile Coated Outer Layers - Embossed, W/Steel Inner Spacer	75mm	.76mm	3185G
Honda	1.6L/1.8L	B16A,B, B17, B18C, DOHC	4	1994-01	Nitrile Coated Outer Layers - Embossed, W/Steel Inner Spacer	79mm	.76mm	3186G
Honda	1.6L/1.8L	B16A,B, B17, B18C, DOHC	4	1994-01	Nitrile Coated Outer Layers - Embossed, W/Steel Inner Spacer	82mm	.76mm	3187G
Honda	1.6L/1.8L	B16A,B, B17, B18C, DOHC	4	1994-01	Nitrile Coated Outer Layers - Embossed, W/Steel Inner Spacer	85mm	.76mm	3188G
Honda	2.2L	H22A1, A2 DOHC	4	1993-96	Nitrile Coated Outer Layers - Embossed, W/Steel Inner Spacer	88mm	.76mm	3191G
Honda	2.2L	H22A1, A2 DOHC	4	1993-96	Nitrile Coated Outer Layers - Embossed, W/Steel Inner Spacer	90mm	.76mm	3192G
Honda	1.8L	B18A1, B1 DOHC	4	N/A	Hybrid Non VTEC Block B18 A/B, B20, VTEC Head B16A/B, B17, B18C Heads	82mm	.76mm	3193G
Honda	1.8L	B18A1, B1 DOHC	4	N/A	Hybrid Non VTEC Block B18 A/B, B20, VTEC Head B16A/B, B17, B18C Heads	85mm	.76mm	3194G
Acura	1.8L	B18A1, B2	4	1990-02	Nitrile Coated Outer Layers - Embossed, W/Steel Inner Spacer	80mm	.81mm	6210G
Honda	1.5L	D15B, D15Z1	4	1988-95	Nitrile Coated Outer Layers - Embossed, W/Steel Inner Spacer	75mm	.81mm	6211G
Honda	1.6L	D16Z6 VTEC	4	1992-00	Nitrile Coated Outer Layers - Embossed, W/Steel Inner Spacer	75mm	.81mm	6211G
Honda	2.2L	F22A1, A6	4	1990-96	Nitrile Coated Outer Layers - Embossed, W/Steel Inner Spacer	85mm	.81mm"	6213G
Honda	2.2L	F22B1, 2	4	1994-97	Nitrile Coated Outer Layers - Embossed, W/Steel Inner Spacer	85mm	.81mm	6214G
Honda	2.3L	H23A1	4	1992-96	Nitrile Coated Outer Layers - Embossed, W/Steel Inner Spacer	87mm	.81mm	6215G
STACKABLE MLS CYLINDER HEAD GASKET								
MAKE	ENGINE	ENGINE DESIGNATOR	CYL	YEAR	DESCRIPTION	GASKET BORE	COMPRESSED THICKNESS	PART NO.
Honda	1.5L	D15Z1 VTEC	4	1991-95	Nitrile Coated Outer Layers - Embossed, W/Steel Inner Spacer	75mm	Adjustable .50mm - 1.75mm	6225
Honda	1.6L	D16Z6 VTEC D16Y5,7,8 VTEC	4	1992-00	Nitrile Coated Outer Layers - Embossed, W/Steel Inner Spacer	75mm	Adjustable .50mm - 1.75mm	6225

GASKETS

SPORT COMPACT ENGINE GASKETS

INTAKE GASKETS

MAKE	ENGINE	ENGINE DESIGNATOR	CYL	YEAR	PART NO.
Acura	1.8L 1834cc	B18A1, B1	4	1990-93	515G
Acura	1.8L 1834cc	B18B1 (GSR)	4	1994-01	518G
Honda	1.6L 1590cc	D16Z6	4	1992-95	516G
Honda	2.2L 2156cc	F22B2,6	4	1994-97	517G

EXHAUST GASKET SPECIFICATIONS AND MODIFIED PORT APPLICATIONS

COPPERSEAL (SOLID COOPER) EXHAUST GASKETS

MAKE	ENGINE	ENGINE DESIGNATOR	CYL	YEAR	PORT DIMENSIONS	COPPER SEAL
Acura						
Integra GS-R	1.7L 1678cc	B17A1	4	1992-93	1.98w x 1.47h	7230
Integra GS-R	1.8L 1797cc	B18C1,5	4	1994-01	1.98w x 1.47h	7230
Integra	1.8L 1834cc	B18A,B1	4	1992-01	1.98w x 1.47h	7230
Eagle						
Talon	2.0L 1997cc	4G63	4	1990-97	2.11w x 1.35h	7235
Talon Turbo	2.0L 1997cc	4G63T	4	1990-97	2.11w x 1.35h	7235
Honda						
Civic CX,DX,LX	1.5L 1493cc	D15B7	4	1992-98	1.86w x 1.40h	7225
Civic Del Sol S	1.5L 1493cc	D15B7	4	1992-97	1.86w x 1.40h	7225
Civic Del Sol SI	1.6L 1590cc	D16Y5, 7, 8	4	1996-00	1.86w x 1.40h	7225
Civic EX,HX,SI	1.6L 1590cc	D16Z6	4	1992-95	1.86w x 1.40h	7225
Civic Del Sol SI	1.6L 1595cc	B16A1,2,3	4	1994-00	1.98w x 1.47h	7230
Accord DX,LX	2.2L 2156cc	F22A1	4	1990-96	1.90w x 1.31h	7220
Accord	2.2L 2156cc	F22A6	4	1990-96	1.90w x 1.31h	7220
Accord	2.2L 2156cc	F22B2	4	1994-98	1.82w x 1.38h	7221
Prelude SI,SE	2.3L 2259cc	H23A1	4	1992-97	1.90w x 1.31h	7220
Mitsubishi						
Eclipse	2.0L 1997cc	4G63	4	1989-94	2.11w x 1.35h	7235
Eclipse	2.0L 1997cc	4G63K	4	1992-93	2.11w x 1.35h	7235
Eclipse Turbo	2.0L 1997cc	4G63T	4	1989-99	2.11w x 1.35h	7235
Nissan						
200SX	2.0L 2000cc	SR20DE	4	1995-99	1.76w x 1.30h	7215
NX2000	2.0L 2000cc	SR20DE	4	1991-93	1.76w x 1.30h	7215
Sentra SE-R	2.0L 2000cc	SR20DE	4	1991-94	1.76w x 1.30h	7215
240SX	2.4L 2389cc	KA24DE	4	1991-01	1.62w x 1.61h	7216
Plymouth						
Laser	2.0L 1997cc	4G63	4	1990-97	2.11w x 1.35h	7235
Laser Turbo	2.0L 1997cc	4G63	4	1990-97	2.11w x 1.35h	7235
Toyota						
Celica	2.2L 2165cc	5SFE	4	1990-01	1.64w x 1.40h	7240
Camry	2.2L 2165cc	5SFE	4	1992-01	1.64w x 1.40h	7240
MR2	2.2L 2165cc	5SFE	4	1991-95	1.64w x 1.40h	7240

SPORT COMPACT ENGINE GASKETS

VALVE COVER GASKETS

MAKE	ENGINE	ENGINE DESIGNATOR	CYL	YEAR	PART NO.
Honda	1.6L 1590cc	D16Z6	4	1992-95	5680G
Honda	2.2L 2156cc	F22A,4,6 / B2,6	4	1990-97	5681G

OIL PAN GASKETS

MAKE	ENGINE	ENGINE DESIGNATOR	CYL	YEAR	PART NO.
Honda	1.6L 1590cc	D16Z6	4	1992-95	6670G
Honda	2.2L 2156cc	F22A,4,6 / B2,6	4	1994-97	6671G

THROTTLE BODY GASKETS

MAKE	ENGINE	ENGINE DESIGNATOR	CYL	YEAR	PART NO.
Honda	1.5L 1493cc	D15B7	4	1988-91	237G
Honda	1.6L 1590cc	D16A6	4	1988-91	237G
Honda	1.6L 1590cc	D16Z6	4	1992-95	238G
Honda	2.2L 2156cc	F22A1, A6	4	1990-96	239G
Acura	1.8L 1834cc	B18A1, B2	4	1990-97	240G
Mitsubishi	2.0L 1997cc	4G63 (SOHC)	4	1989-92	241G
Toyota	2.2L 2165cc	5SFE	4	1990-96	242G
Nissan	2.0L 2000cc	SR20DE	4	1994-97	243G
Nissan	2.4L 2389cc	KA24DE	4	1991-97	243G



7225▲



238G

GASKETS



7100▲

ENGINE REBUILDER OVERHAUL GASKET KITS

Designed for stock, non-high performance engines, these overhaul gasket kits include all gaskets and seals needed to rebuild most popular V8 engines.

ENGINE OVERHAUL GASKET KITS

MAKE	ENGINE	YEAR	PART NO.
AMC	390-401	67-78	7118
Buick	350	68-81	7141
	400-455	67-76	7142
Chevrolet	265-350	57-79	7100
	283-350 w/Steel Shim Head Gasket	57-74	7104
	305	87-93	7146
	305	86	7147
	305	80-85	7148
	305	76-79	7149
	350	80-85	7101
	350	1986	7102
	350	87-91	7103
	400	70-80	7108
	396-454	65-79	7106
	Chrysler	273-318	67-81
360		71-81	7112
383-440		63-78	7115
Ford	221-302	62-82	7120
	302	83-91	7121
	351W	69-74	7123
	351W	75-82	7124
	351W	83-91	7125
	351C/M-400 (2 Bbl.)	71-79	7127
	390-428	61-71	7129
	429-460	68-85	7130
Honda	1.5L 1493cc D15B1, B2	1988-91	7040G
	1.6L 1590cc D16A6	1988-91	7040G
Mitsubishi	2.0L 1997cc 463B SOHC	1989-92	7041G
	2.0L 1997cc 4G63 DOHC	1989-92	7042G
Oldsmobile	350-455	65-76	7140
Pontiac	350-455	65-71	7145

FUEL BOWL AND METERING BLOCK GASKETS FOR HOLLEY CARBURETORS

Available in matched pairs or packaged five per set, these gaskets fit the Holley carburetors listed below. The #6180 series gaskets are made from a rubber coated material designed to minimize swelling and withstand high underhood temperatures. Some carburetors within the same model series differ, check your particular carburetor to make sure you're getting the correct gaskets.

HOLLEY CARB. MODEL NUMBER	DESCRIPTION	QUANTITY	PART NO.
2300, 4150, 4160	Fuel Bowl and Metering Block Gasket set	1 each per set	1509
4150, 4160, 4165	Primary Metering Block Gaskets	5 per set	6180
2300, 4150, 4160	Metering Block Gaskets	5 per set	6181
4160, 4175	Secondary Metering Block Gaskets	5 per set	6182
2300, 4150, 4160, 4500	Fuel Bowl Gaskets	5 per set	6183
4150	Fuel Bowl and Metering Block Gasket Set	2-each per set	6177
4160	Fuel Bowl and Metering Block Gasket Set	2-each per set	6178
4500	Fuel Bowl and Metering Block Gasket Set	2-each per set	6179

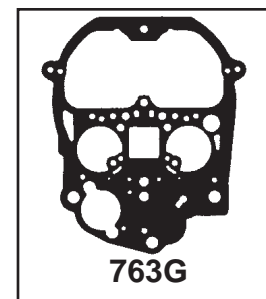
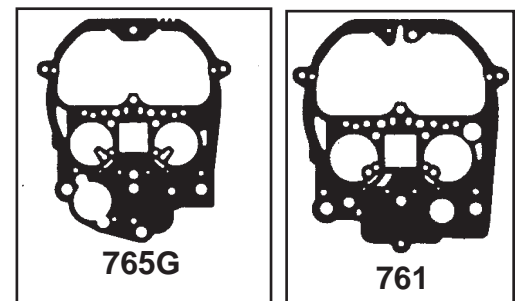
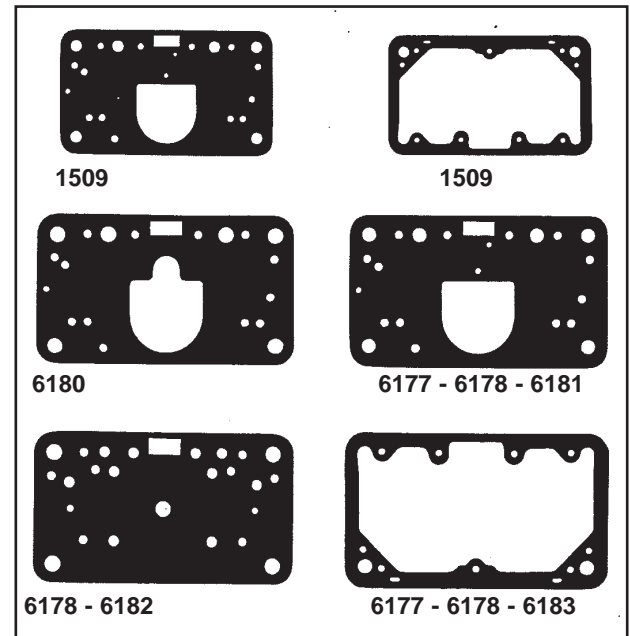

QUADRAJET AIRHORN (UPPER) AND THROTTLE BODY (LOWER) GASKETS

Two of the most common problems with Quadrajets carburetors are a stuck power valve and/or leaking secondary well plugs. These gaskets eliminate the necessity of a complete (and expensive) carburetor rebuilding kit. The new gaskets are universal in that they fit most Quadrajets carburetors as is; however, the O.E.M. gasket should be compared to the Mr. Gasket gasket, as a few small holes may have to be made in the gasket to fit the particular application. Three part numbers are all that is required to fit the millions of Quadrajets carburetors in existence.

- Universal Quadrajets Airhorn Gasket, '66-74761
- Universal Quadrajets Airhorn Gasket, '75-77 & some '78-81763G
- Universal Quadrajets Airhorn Gasket, most '78-81765G

CARBURETOR BASE VIBRATION ISOLATOR GASKETS

Mr. Gasket's carburetor base vibration isolator is designed to increase horsepower in high power and high vibration applications. Made from 1/4" thick closed cell foam rubber material it acts as a shock absorber to dampen fuel vibration, reduce fuel foaming, cuts down on erratic needle/seat motion and stabilizes fuel curve in the carburetor fuel bowls.

- Holley and Demon square flange 4-bbl. carburetors.
Fits open center intake manifold4277G
- Holley and Demon square flange 4-bbl. carburetors.
Fits 4-hole intake manifold.4278G
- Holley Dominator and King Demon carburetors.
Fits open center intake manifold4279G
- Holley Dominator and King Demon Carburetors.
Fits 4-hole intake manifold4280G

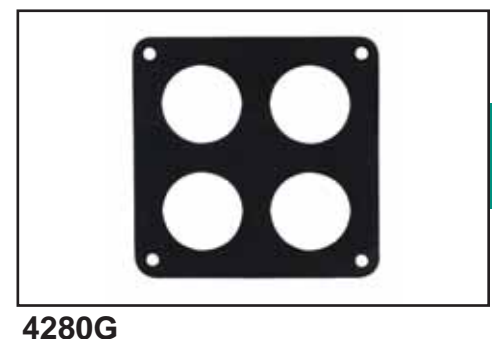

GASKETS

CARBURETOR BASE GASKETS

These carburetor base gaskets are made from a durable heat-resistant nitrile rubber compound material and precision die cut for an excellent fit. They come in either 1/16" or 1/4" thicknesses. Available skin packaged or bulk.

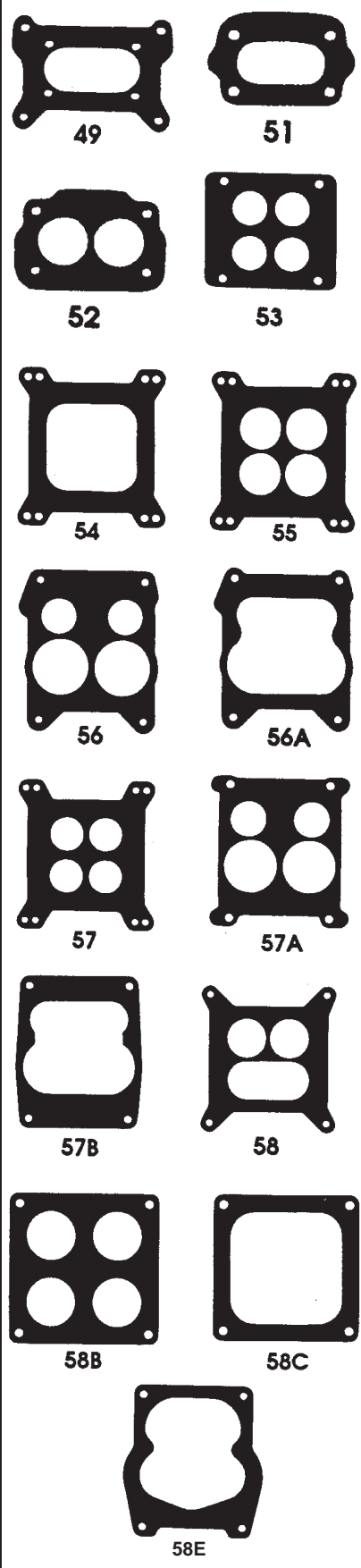

APPLICATIONS	MR. GASKET BULK PACKAGED 1/16" THICK	MR. GASKET SKIN PACKAGED 1/16" THICK	SUPER CARB GASKET SKIN PACKAGED 1/16" THICK	MR. GASKET SKIN PACKAGED 1/4" THICK
HOLLEY CARBURETORS				
4 bbl. - Open Center	54	54C	4254G	757
4 bbl. - Open Center	54	54C	4254G	757
fits 1 3/4" bore 850, 950, 1000 cfm carbs				
4 bbl. - 4 Hole - 1 3/4" Bore	55	55C	4255G	758
fits most square flange carbs				
4 bbl. - 4 Hole Or Open Center		48C		
perforated center can be removed				
4 bbl. - 4 Hole - 4500 Dominator	58B		4258G	
4 bbl. - Open Center - 4500 Dominator	58C		4257G	
2 bbl. - Split 4500 Dominator, Atpr Pit Top			4260G	
2 bbl. - Split 4500 Dominator, Atpr Pit Btm			4261G	
4 bbl. - Open Center - Spread Bore	58E			
3 bbl. - 3 Hole	58			
2 bbl. - Open Center - 350/500 CFM	49	49C	4249G	
CARTER CARBURETORS				
4 bbl. - 4 Hole - 1 1/2" Bore, 4GC/WCFB		50G		
4 bbl. - Open Center - AFB, AVS	54	54C	4254G	
4 bbl. - 4 Hole - 1 3/4" Bore	55	55C	4255G	
4 bbl. - 4 Hole Or Open Center		48C		
perforated center can be removed				
4 bbl. - 4 Hole - 1 7/16" Bore	57	57C		
4 bbl. - 4 Hole - Thermo Quad	57A			
4 bbl. - Open Center - Thermo Quad	57B			
DEMON CARBURETORS				
4 bbl. - Open Center - Race, Speed, Road	54	54C	4254G	757
4 bbl. - 4 Hole - Race, Speed, Road	55	55C	4255G	
4 bbl. - 4 Hole Or Open Center		48C		
perforated center can be removed				
4 bbl. - 4 Hole - King	58B		4258G	
4 bbl. - Open Center - King	58C		4257G	
2 bbl. - Split King, Adapter Plate Top			4260G	
2 bbl. - Split King, Adapter Plate Bottom			4261G	
EDELBROCK PERFORMER CARB				
4 bbl. - Open Center - Square Flange Carbs	54	54C	4254G	757
EDELBROCK Q-JET CARBS				
4 bbl. - 4 Hole	56	56C	4256G	759
4 bbl. - Open Center	56A			
ROCHESTER CARBURETORS				
4 bbl. - 4 Hole - Square Flange Carb	53			
4 bbl. - 4 Hole - Quadrajet	56	56C	4256G	759
4 bbl. - Open Center - Quadrajet	56A			
2 bbl. - Open Center	51			
Small Base 1 7/8" x 3 1/4"				
2 bbl. - 2 Hole	52			
Large Base 2" x 3 11/16"				

NOTE: Super Carburetor Base Gaskets are made from premium MRG 4200 material and provide superior torque retention, crush resistance and shear strength. These gaskets seal using low clamp force, release easily; will not stick to carburetor or intake manifold and can be reused.

AIR CLEANER BASE GASKET

Made from a high-quality, 1/16" thick gasket material, this Air Cleaner Base Gasket is precision die cut for an exact fit.

Fits 4 and 2 Bbl. Air Cleaners w/5 1/8", 4 7/32", 3" and 2 5/8" Dia. Base**6185**
 Holley Dominator Air Cleaner Gasket.....**6186**

TUNNEL RAM MANIFOLD GASKETS

These ram manifold gaskets are manufactured from a 1/16" thick, cellulose nitril compound noted for durability and sealing characteristics. Two per kit.

Fits Edelbrock TR-1X and TR-1Y **665**

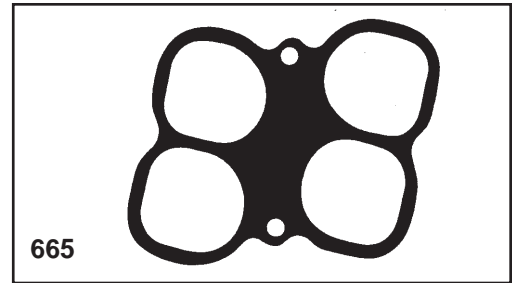

SUPERCHARGER GASKETS

Mr. Gasket blower gaskets are manufactured from the highest-quality materials and precision-cut for an excellent seal and fit.

APPLICATIONS	GASKETS
GMC	
471 base gasket 1/32" thick	471
671,871 base gasket 1/32" thick	671G
671,871 base gasket 1/16" thick	674G
671/871 injector base gasket 1/16" thick	672G
671/871 injector base gasket with screen 1/16" thick	673G

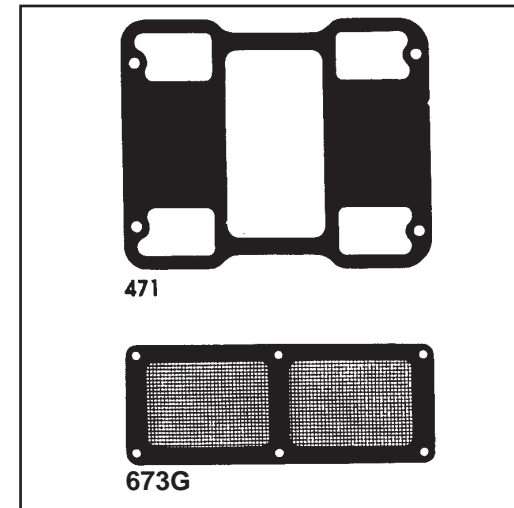

SUPERCHARGER FRONT COVER GASKET SET

These gaskets fit all GMC and most aftermarket 71 Series Superchargers, except "V" styles. Made from a high-quality .045 thick coated material, this set includes a front cover, drive housing and block-off plate gasket, precision die cut for an exact fit.

Supercharger Front Cover Gasket Set **770G**

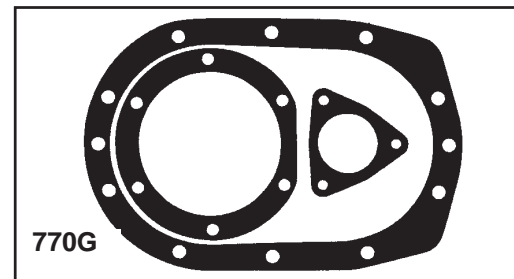

FUEL CELL GASKET

Fits all oval-shaped inlet flange cells. One per kit.

Overall 8" x 12" **675**

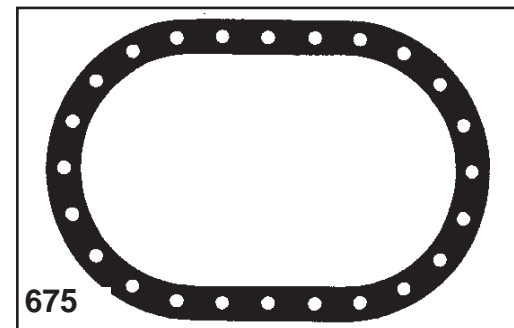

HEADER GASKET & FASTENER INSTALLATION KITS

Includes gaskets and fasteners necessary for header installation. Premium Ultra-Seal exhaust and collectors gaskets provide excellent heat resistance, conform to and seal minor surface irregularities. Mr. Gasket header and collector bolts deliver the necessary force (clamp-load) needed to seal flange mating surfaces.

PART NO.	APPLICATION	YEAR	CID	LITERS	HEADER FLANGE TYPE
7650G	Chevrolet V-8	1955-91	265-400	4.3-6.6	Square Port
7651G	Chevrolet V-8	1955-91	265-400	4.3-6.6	Round Port
7652G	Chevrolet V-8	1955-91	265-400	4.3-6.6	Oval Port
7653G	Chevrolet V-8	1965-99	396-454	6.5-7.4	Square Port
7654G	Chevrolet V-8	1965-99	396-454	6.5-7.4	Round Port
7656G	Chrysler V-8	1975-91	318	5.2	Rectangle Port
7656G	Chrysler V-8	1968-91	340,360	5.6-5.9	Rectangle Port
7657G	Chrysler V-8	1959-78	383,440	6.3-7.2	Rectangle Port
7659G	Ford V-8	1965-95	289,302, 351W	4.7-5.7	Rectangle Port
7660G	Ford V-8	1986-95	302	5.0	Oval Port
7664G	Oldsmobile V-8	1964-76	330-455	5.4-7.5	Rectangle Port
7665G	Pontiac V-8	1964-79	326-455	5.3-7.5	D-Port Port Center



7650G

GASKETS

COLLECTOR AND HEADER MUFFLER GASKETS

Collector/header muffler gaskets are designed to prevent exhaust leakage between the header and collector flanges. Bulk gaskets are sold individually, packaged gaskets are sold 2 per set. (Except where noted)

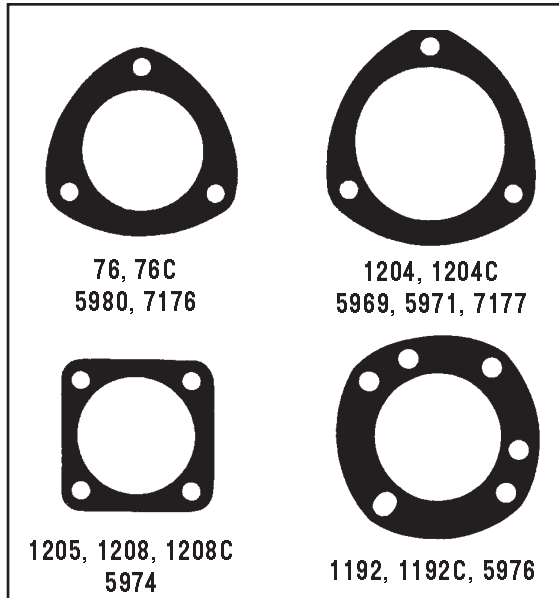

TRIANGLE – 3 BOLT HOLES

DIA.	BOLT CIRCLE	BOLT HOLE	APPLICATIONS	BULK PERF.	PKG. PERF.	ULTRA SEAL	COPPER SEAL
2-1/2"	3 1/2"	3/8"	Dynomax Flowtech, Hedman, Hooker	76	76C	5980	7176C 7176 ⁽³⁷⁾
2-3/4"	3 1/2"	3/8"	Hush Thrush Muffler #510 Various			5970	
3"	3 7/8"	3/8"	Dynomax Flowtech, Hedman, Hooker, Thorley	1204	1204C	5969 ⁽³⁷⁾ 5971	7177C 7177 ⁽³⁷⁾
3-1/2"	4 7/16"	3/8"	Dynomax Flowtech, Hedman, Hooker, Thorley	1203	1203C	5972	7178C 7178 ⁽³⁷⁾

⁽³⁷⁾ Bulk each



ROUND – 3 AND 4 BOLT HOLES

DIA.	BOLT CIRCLE	BOLT HOLE	APPLICATIONS	BULK PERF.	PKG. PERF.	ULTRA SEAL
2-7/8"	3-3/4" 3 Bolts 4" 4 Bolts	7/16"	Hush Thrush Muffler 513	1192	1192C	5976
3 3/8"	4-3/8" 3 Bolt 4 1/2" 4 Bolt	3/8"	Hush Thrush Muffler 514	1193	1193C	5979

SQUARE – 4 BOLT HOLES

DIA.	BOLT CIRCLE	BOLT HOLE	APPLICATIONS	BULK PERF.	PKG. PERF.	ULTRA SEAL
2 1/2"	3 5/16"	3/8"	Blackjack 382 and others	1190	1190C	5973
3"	4 1/16"	7/16"	Blackjack 382 and others	1205	1205C	5974
3 1/2"	4 9/16"	3/8"	Blackjack 382 and others	1209		
3 1/2"	5"	3/8"	Blackjack 382 and others	1206		

FLANGE GASKETS FOR THRUH CVX POWER SYSTEM

These gaskets seal the flanges of the CVX power systems below. They are made from high-quality exhaust material and assure a leakproof seal. 2 per package

CVX SYSTEM#	QUANTITY OF GASKETS REQUIRED FOR SYSTEM	ULTRA SEAL #
C18535	1	5971
C18536	1	5971
C18674	2	5971

AUTOMATIC TRANSMISSION OIL PAN GASKETS

If your automatic transmission is leaking because of a bad pan gasket, replace it with a new one from Mr. Gasket. Mr. Gasket's Performance gaskets are pre-cision made from a cork/neoprene material which features excellent compressibility and greater thickness recovery for a positive seal. Individually packaged, these gaskets are available for the following transmissions:

GM TH 700 R4.....	8695
GM TH 350.....	8690
GM TH 400.....	8691
GM powerglide.....	8693
Ford C-6.....	8694
Chrysler – 727.....	8697

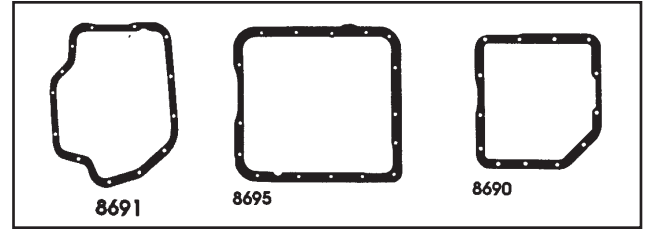

FIBER GASKET MATERIAL

Pliable and chemically treated durable fiber, this gasket material is resistant to oil, gasoline and water. Ideal for use on transmission side covers, etc. Poly bagged.

1/64" x 9" x 36" sheet.....	9610
1/32" x 9" x 36" sheet.....	9611

CORK GASKET MATERIAL

Used in any application where a part must be sealed to prevent oil leakage. used to make intake manifold end seals, timing cover gaskets, etc. Poly bagged.

1/16" x 12" x 36" sheet.....	9612
1/8" x 12" x 36" sheet.....	9613

COMPRESSED GASKET MATERIAL

Used where extreme heat and pressure sealing are required, like exhaust gaskets. Poly bagged.

1/32" x 12" x 18" sheet.....	9614
1/16" x 12" x 18" sheet.....	9615

EXHAUST GASKET MATERIAL

BULK PACKAGED

Mr. Gasket's own 1/16" thick exhaust gasket material – used for special applications.

10" x 10" Performance material.....	77
6" x 24" Performance material.....	77A
10" x 10" Ultra-Seal material.....	5960
6" x 24" Ultra-Seal material.....	5961

INTAKE GASKET MATERIAL

BULK PACKAGED

Mr. Gasket's own 1/16" thick intake gasket material – used for special applications.

12" x 12".....	77B
6" x 24".....	77C

GASKET MATERIAL

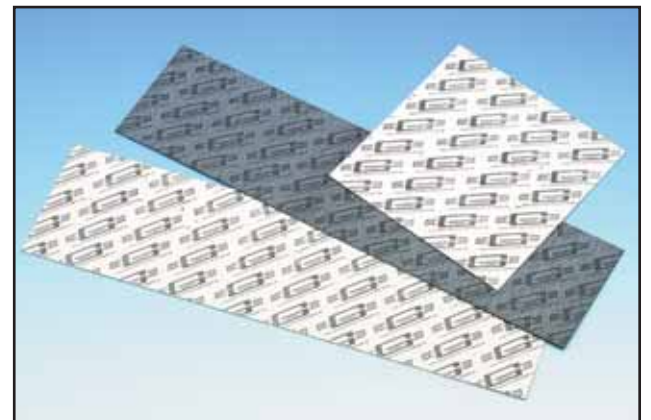

GASKETS / SEALANTS

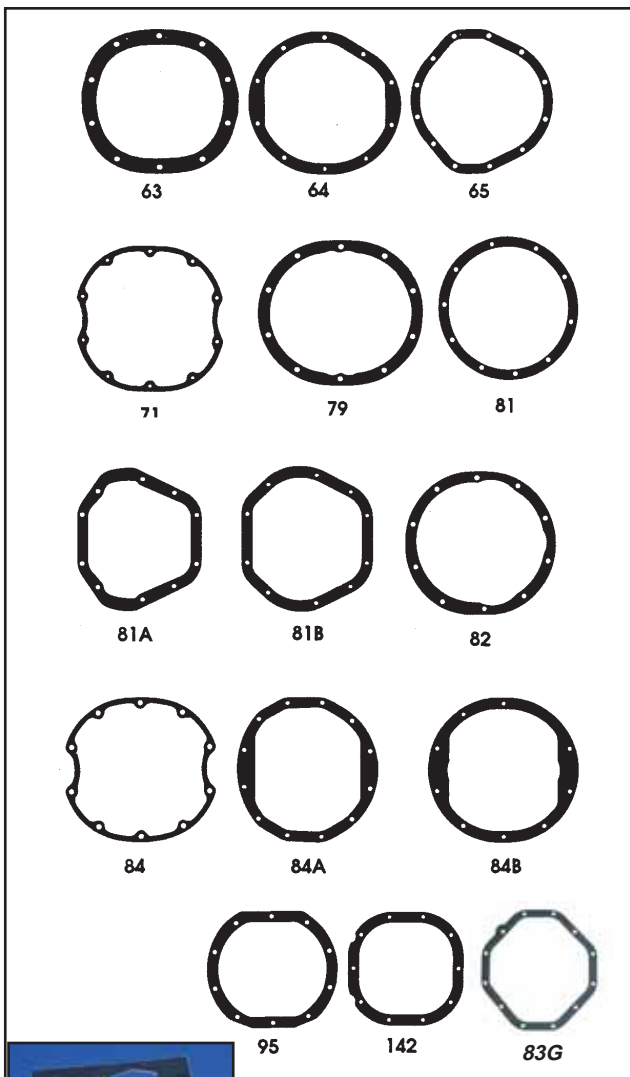

BLUE RTV SILICONE SEALER

The original blue. Makes reliable "formed-in-place" gaskets. Resists cracking, shrinking and migrating. Coats pre-cut gaskets to increase reliability. Temperature range -65°F to 500°F intermittent; resists auto and shop fluids.

Application includes valve covers, oil pans, intake manifold end seals, timing covers, water pumps, thermostat housings.

Blue RTV Silicone Sealer 3 oz. tube.....**7808**

DIFFERENTIAL REAR END GASKETS

Precision die cut for excellent seal and fit, rear end gaskets are made from the same high-quality materials as all Mr. Gasket gasketse.

APPLICATIONS	PART NO.
Chevrolet 10 Bolt 8.20" Ring Gear 1955-64	79
GM 10 Bolt w/7.50" Ring Gear 77-86, exc. Monza & Vega	63
Chevrolet & GM Truck 10 Bolt 77-90 Front differential	64
GM 10 Bolt 8.20" Ring Gear 64-71	71
Buick, Olds, Pontiac, Chevrolet 10 Bolt 8.20" Ring Gear 65-81	84
Chevrolet 10 Bolt w/ 8.50" Ring Gear 70-81	84B
Chevrolet & GMC Truck 12 Bolt 64-82 8.875 Ring Gear, Rear Differential	65
Chevrolet/GM 12 Bolt 8.875" Ring Gear 65-72 Passenger Car	84A
Ford 10 Bolt 9" Ring Gear 57-81	82
Ford 10 Bolt, 7.50" Ring Gear 79-96	95
Ford 10 Bolt 8.80" Ring Gear 81-06	142
Chrysler 12 Bolt 8.750 Ring Gear 61-74	81
Chrysler Dana 60 & 70 12 Bolt 9.750" Ring, Gear 66-84; Dodge/Plymouth Car & Truck Ford/Chrysler Truck	81A
Chrysler Dana 44 10 Bolt 8.50" Ring Gear 67-85 Ford/Chrysler/Chevrolet Truck, Jeep Front Differential	81B
Dodge Truck 9.25" Ring Gear 1986-98	83G

OVERHAUL GASKET KITS FOR 4-SPEED TRANSMISSIONS

These reusable gaskets let you check the transmission gears for wear without the extra expense of replacement gaskets. Extra thin gasket material is standard.

APPLICATIONS	PART NO.
Borg-Warner T-10 and Super T-10 1957-79 without tailshaft seal	2491
Muncie 1963 thru mid 74 with tailshaft seal	2492

ULTRA-SEAL PORT GAUGE

This convenient gauge allows you to make sure your customer is getting the correct gasket for the application.

Since there are so many different cylinder heads on the market today and because Mr. Gasket has gaskets to fit just about any combination, it gets very confusing to buy the right gasket for each application. With the PORT GAUGE all you do is match the correct template to the head and then read the part # on the template.

There are 19 Small Block Chevy intake templates and 9 Big Blocks. Constructed of plastic and held together with a steel ring, it can be hung in a convenient spot for quick reference.

Ultra-Seal Port Gauge.....**73074G**

GASKET INSTALLATION TIPS

Great care should be taken when installing any gasket since the performance and longevity of your engine directly depends on having the optimum seal. Below are some installation tips that will help you obtain a better seal on various parts of your engine.

BASIC GUIDELINES

Keep in mind one of the most important requirements of building an engine is to keep everything as clean as possible; this applies to gaskets and gasket mating surfaces also. Every surface a gasket comes in contact with must be free of dirt, water, oil, grease, etc. The surface must also be flat, warpage should not exceed .0025" in any direction. Take special care to clean surface of old gasket material that may have stuck to either the part (oil pan, intake manifold, etc.) or the cylinder heads and block. One point often overlooked is keeping the gaskets themselves clean. This is one reason Mr. Gasket skin packages gaskets. The gaskets should not be taken out of the package until you are ready to install them.

HEAD GASKETS

After all gasket mating surfaces have been carefully cleaned, place a straight edge across cylinder head and engine block gasket surface. Flatness should not vary more than .0025", if a variance of more than .0025" is measured, we recommend correcting this situation before installing gasket.

Re-tap and thoroughly clean all head bolt/stud threaded holes. If existing bolts or studs are being reused, clean threads and lightly lubricate to insure accurate torque readings.

NOTE: Torque specs will vary with type of lubrication used.

- Use fresh 10W30 weight motor oil and follow bolt/stud manufacturer's recommendation.
- Use a thread sealer with teflon on bolt holes that enter into cooling passages.

- Do not use any type of adhesive or sealer on Mr. Gasket/Ultra-Seal head gaskets. The special coatings used on the gaskets are more than adequate to properly seal all fluid passages and minor surface imperfections.

Applying proper clamp load is one of the most important steps to a successful seal. After installing head gasket and cylinder head, tighten bolts/studs following engine manufacturer's recommended torque sequence. Tighten in at least three equal steps moving the torque wrench in a smooth, even pull, which will yield the most accurate torque readings. The use of Mr. Gasket hardened washers will further reduce friction and increase torque accuracy.

INTAKE GASKETS

Many performance engines have machined surfaces that cause non-parallel alignment. Before assembly, insure head and manifold mounting surfaces are parallel and head ports properly match intake ports. We offer a wide variety of port sizes to match many different port configurations, however, our performance intake gaskets can be easily cut to match most modified cylinder head and intake ports if necessary.

Inspect original gasket (if available) to determine if: Mounting surfaces are parallel, ports are properly matched to head, or if manifold is warped.

- Clean all mounting surfaces before installing new gasket.
- Be careful not to damage mounting surface when using a scraper or wire brush.
- Use gasket remover to ease clean-up
- Cover open internal areas (lifter galley and ports) so debris will not get into and damage critical engine components.

GASKETS

IMPORTANT: If engine is equipped with valley pan type gasket, do not discard. On most engines, this pan may need to be used to insure proper oil drain back to crank case. Clean valley pan and apply a thin bead of Mr. Gasket #7808 silicone around ports on cylinder head side of valley pan. Place in position on engine, then continue to install the Mr. Gasket intake set.

Use adhesive around water and intake ports on cylinder head side of gasket to insure a tight seal and keep the gasket from moving during manifold installation.

NOTE: On large port applications, the gasket wall between ports is very narrow. Be sure adhesive has cured adequately before installing intake manifold to avoid gasket shift.

WARNING: For long term sealing, do not use any type of copper gasket sealer on intake gaskets. Do NOT use any sealants on o-ringed ports!

END SEAL INSTALLATION (IF APPLICABLE)

Manifold front and rear end seals are supplied with most kits, but in many performance applications the manifold end gap has been reduced due to machine work done to block and heads.

- If light machining has been done, discard the rubber seals (if supplied) and use the cork seals (apply an 1/8" bead of Mr. Gasket #7808 silicone sealer at side rail/seal inter-section).
- If gap is smaller than 3/32", discard cork seals and use Mr. Gasket #7808 sealer and apply a 1/4" bead across block surface, then install intake manifold.

Install bolts fingertight, then using a torque wrench, tighten to factory torque specifications. Follow proper tightening sequence. (On most V8 engines, start with center bolts, then work outward in an "X" pattern).

EXHAUST GASKETS

A unique feature on many of our exhaust gasket applications is the slotted end holes allowing you to easily slide the gasket between the cylinder head and header flange after the end bolts have been started. An alternate method on gaskets without the slotted end holes is to use starter studs or Ultra-Seal header studs to temporarily hold the gasket in place.

Slide the header flange onto the studs and, if using starter studs, replace with the proper type of header bolts.

CAUTION: Use care not to over-tighten headers, as this can warp the flanges causing an exhaust leak. It does not matter which side of the exhaust gasket is placed against the cylinder head or header flange.

NOTE: No gasket sealer is needed with the installation of Mr. Gasket, Ultra-Seal and CopperSeal exhaust gaskets.

VALVE COVER AND OIL PAN GASKETS

If existing valve covers or oil pan are being reused, clean and degrease before installing. Use gasket remover to aid in the removal of old gasket material. Check for warped or bent flanges and straighten as necessary (This is very important to insure a good, tight, leak-proof seal).

- Clean any oil residue off of valve cover or oil pan flange surfaces, and apply a thin coat of Mr. Gasket #7808 silicone to hold gaskets in place during installation.
- Install mounting bolts and tighten evenly in a criss-cross pattern. Use care not to over tighten, as this will cause the flanges to bend.