

**X-7425**

# **1973 GMC Motorhome Maintenance Manual**

## **Table of Contents**

Section	Description
0	Information, Periodic Maintenance and Lubrication
1	Body, Heating and Air Conditioning
2	Frame
3A	Front Suspension
3B	Drive Axles
3C	Final Drive
4	Rear Suspension
5	Brakes
6A	Engine
6K	Engine Cooling
6M	Engine Fuel System
6T	Emission Control Systems
6Y	Engine Electrical
7	Transmission
8	Fuel Tank and Exhaust
9	Steering System
10	Wheels and Tires
12	Chassis Electrical
13	Radiator and Coolant Recovery System
14	Bumpers
24	Miscellaneous Living Area Facilities
24A	Periodic Maintenance and Lubrication
24B	Living Area Electrical System
24C	Motor Generator
24D	Refrigerator
24E	Roof Mounted Air Conditioner (Information not available at time of publication)
24F	LP Gas System
24G	Furnace
24H	Range/Oven
24J	Living Area Water System
24K	Toilet
24L	Holding Tank and Drainage System
24M	Thermasan System
24N	Cabinets and Furniture
24P	Exhaust Vents
24Q	Other Equipment (Vacuum Cleaner) Wiring Diagrams



# SECTION 0 GENERAL INFORMATION, PERIODIC MAINTENANCE, AND LUBRICATION

Contents Of This Section Are Listed Below:

SUBJECT	PAGE NO.
Vehicle Identification .....	0-1
Component Identification .....	0-2
Hoisting Instructions.....	0-2
Jack Usage Instructions .....	0-3
Towing Motor Home .....	0-4
Engine, Chassis, and Body Maintenance Schedule .....	0-6
Explanation of Maintenance Schedule .....	0-7
Recommended Fluids and Lubricants .....	0-10
Lubrication Details.....	0-11
Winterization and Vehicle Storage .....	0-15

## VEHICLE IDENTIFICATION

The Vehicle Identification and Weight Rating Plate (figure 1) located behind the right front access door shows the "Vehicle Identification Number", and the "As Manufactured" Gross Vehicle Weight Rating for the Motor Home to which it is attached.

In order that the vehicle may be specifically identified as to manufacturer, engine type, year of manufacture, etc., refer to Figure 2.

**GENERAL MOTORS CORPORATION**

WARRANTY MAY BE VOIDED IF WEIGHT EXCEEDS ANY OF THE RATINGS SHOWN.

GROSS VEHICLE WEIGHT INCLUDES WEIGHT OF BASE VEHICLE, ALL ADDED EQUIPMENT, DRIVER AND PASSENGERS, AND ALL PROPERTY LOADED INTO OR ONTO VEHICLE.

	RATINGS IN POUNDS AS MANU- FACTURED
GROSS VEHICLE WEIGHT FOR THIS VEHICLE	<input style="width: 50px;" type="text"/>
MAXIMUM FRONT END WEIGHT AT GROUND	<input style="width: 50px;" type="text"/>
MAXIMUM REAR END WEIGHT AT GROUND	<input style="width: 50px;" type="text"/>

VEHICLE IDENT. NO.

A-2329

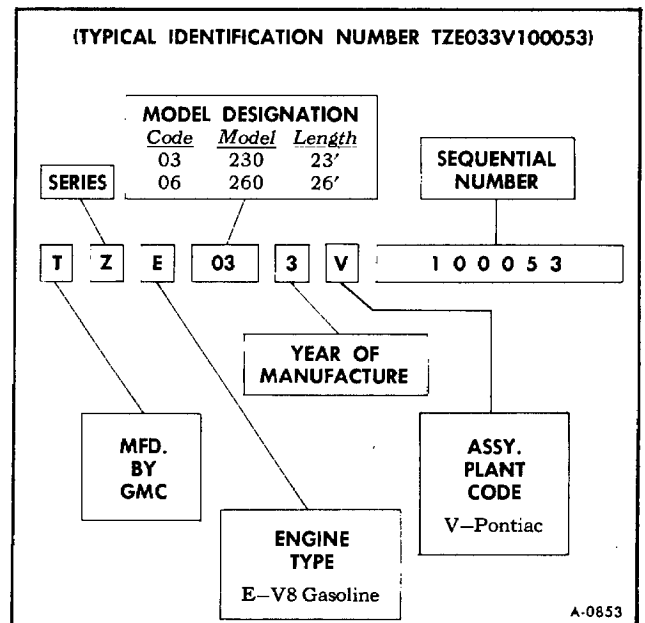

Figure 1-Vehicle Identification Plate

Figure 2-Vehicle Identification Number



## COMPONENT IDENTIFICATION

### ENGINE

Motor Home engines are identified by a code tape installed directly above the engine serial number which is stamped on the engine oil fill tube (figure 3).

### TRANSMISSION

The transmission model and code numbers are stamped on the converter housing as shown in Figure 4.

### FINAL DRIVE

The ratio and date codes are stamped on the flange near the right hand spreader hole as shown in Figure 5.

**Date Code:** The code letter is for the month and the number(s) are for actual date.

**Ratio Code:** "T" = 3.07:1    **EXAMPLE:** T A12 = 3.07:1, built January 12 (J = 9th month, I is not used).

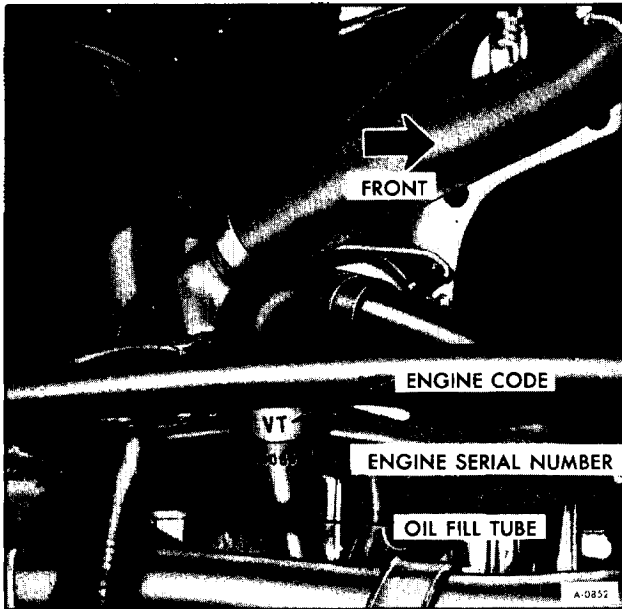

Figure 3-Engine Identification

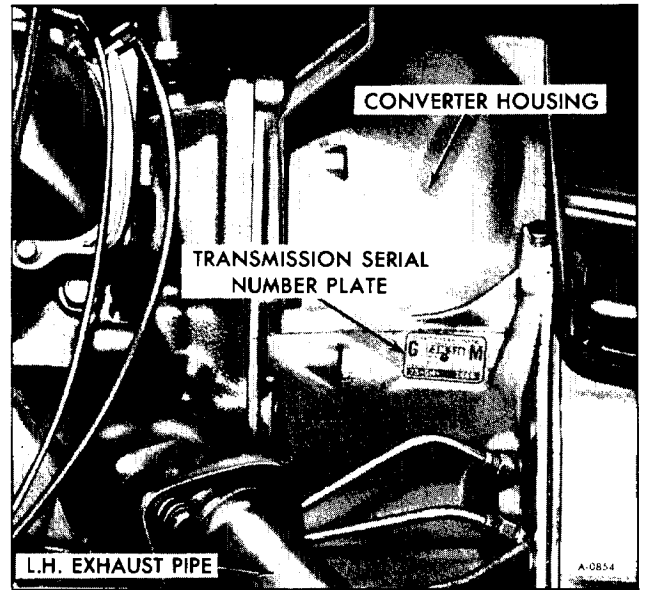

Figure 4-Transmission Serial Number Plate

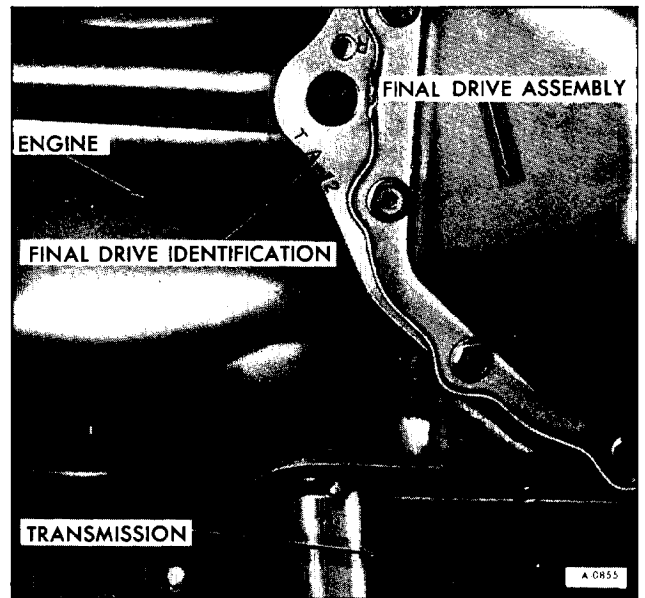

Figure 5-Final Drive Identification

## HOISTING INSTRUCTIONS

A twin post hoist of sufficient capacity and with proper adapters and/or fittings must be used.

Front hoisting position is the front engine cross-member.

Rear hoisting must be done at the rear suspension brackets. If an "I" beam type adapter is used it should be approximately 82 inches in length to gain adequate support at suspension brackets. (figure 6)

If vehicle is to be placed on jack stands for maintenance or repairs, the hoisting points should be used.

**CAUTION:** To help avoid serious damage to your Motor Home, the vehicle should be raised only on twin post hoists of 15,000 pounds or more total rated capacity, at the suspension points noted (see diagram). Before raising, check overhead clearance to see that it is sufficient for the Motor Home. Do NOT use the vehicle jack for hoisting or maintenance. It is designed for use only when changing tires.

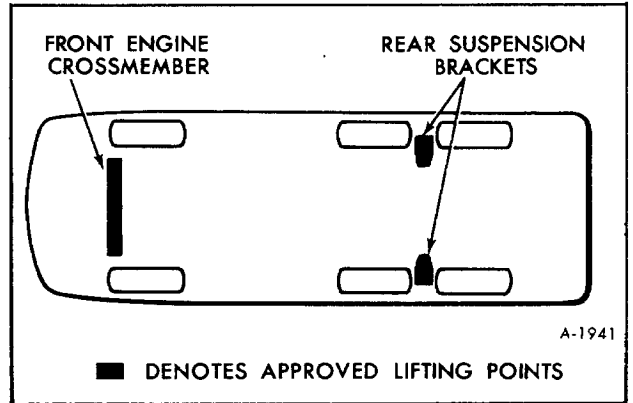

Figure 6—Motor Home Hoisting Points

## JACK USAGE INSTRUCTIONS

### CAUTIONS

1. Follow jacking instructions in order to reduce the possibility of serious personal injury.
2. The jack is designed for use only when changing wheels.
3. Never get beneath the vehicle when using jack.
4. Do not start or run engine while vehicle is on jack.

### INSTRUCTIONS

- Park on level surface and set parking brake firmly.
- Set transmission in "PARK".
- Activate Hazard Warning Flasher.
- Jack, jack chain, handle, "jacking pad" (wooden block), and lug wrench are located under dinette seat.
- Block both front and rear of the wheel diagonally opposite the jack position.
- Loosen but do not remove wheel nuts.
- **JACKING AT FRONT**—Place hydraulic jack on wood block near energy absorbing front bumper bracket. Place hook at flange of front cross-member. Pass chain under bumper and adjust chain length to snug fit on fork on top of jack (See figure 7).

- **JACKING AT REAR**—Place hydraulic jack on wood block close to rear suspension bracket (See figure 8). The hook is placed in the drainage slot under bracket. Adjust chain length so link will fit in fork at top of jack.
- Close valve at base of jack and insert jack handle.

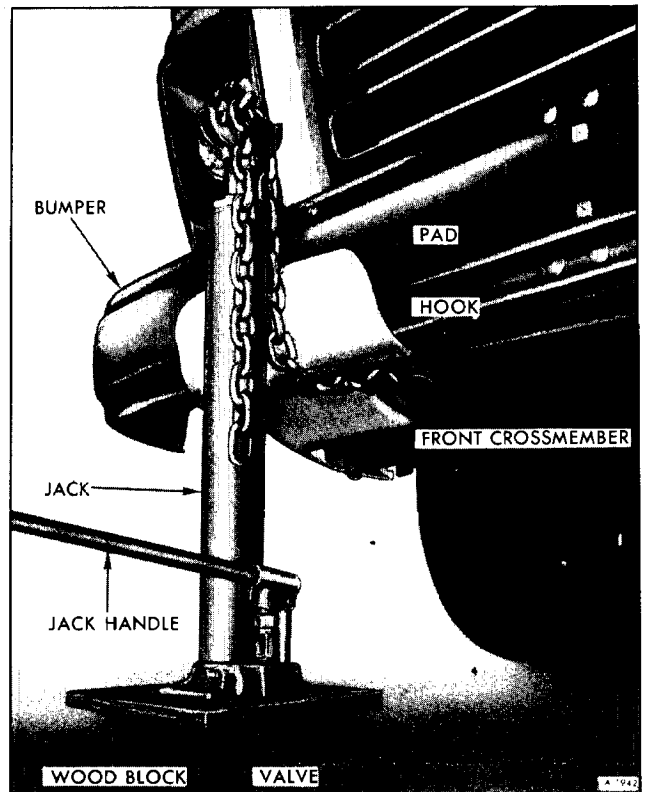

Figure 7—Jacking at Front of Motor Home

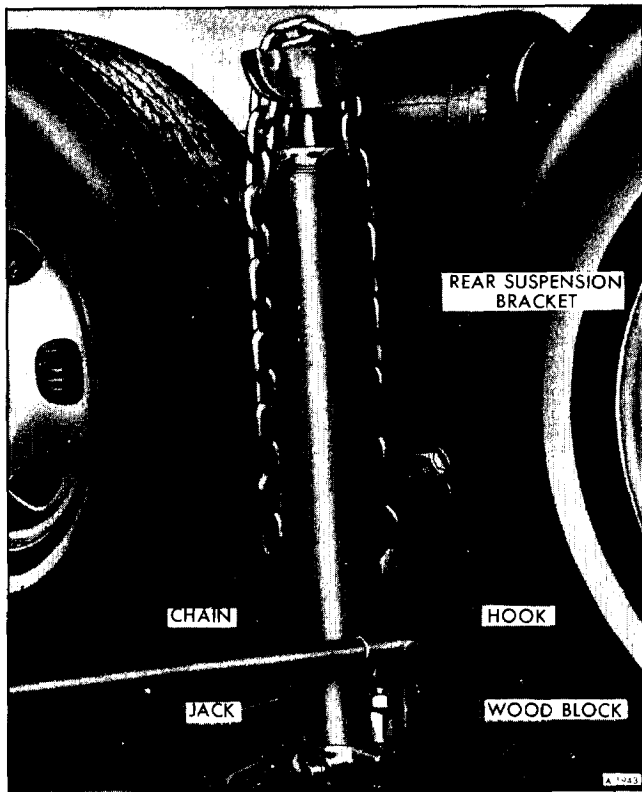

Figure 8—Jacking at Rear of Motor Home

- Always operate jack with slow, smooth motion.
- Raise vehicle so tire just clears surface, replace wheel and slightly tighten wheel nuts.
- Open valve at base of jack to lower, then fully tighten wheel nuts. Proper torque is 250 foot pounds.

**CAUTION:** Use lug wrench provided to tighten wheel nuts securely if torque wrench is not available. (Follow the nut tightening sequence shown in *WHEELS AND TIRES*, Section 10 of this manual. At the earliest opportunity have wheel nut torque checked. This is necessary to help prevent loosening or stripping of the wheel nuts.

## TOWING MOTOR HOME

Proper lifting or towing equipment is necessary to prevent damage to the GMC Motor Home during any towing operation. State (Provincial in Canada) and local laws applicable to vehicles in tow must also be followed. The Motor Home may be towed on all six wheels at speeds of less than 35 MPH, for distances up to 50 miles, provided final drive, axle, and transmission are otherwise normally operable. For such towing, parking brake must be released, transmission must be in neutral, and the ignition key turned to OFF position.

## TOWING AT FRONT (FIGURE 9)

**NOTE:** Attachments must be to frame front crossmember of the Motor Home, not to bumpers or bracketing. Separate safety chains or cables should be used. Care must be taken in installation of chains to ensure that they do not cause damage. Remember that power brake and steering assists will not be available when engine is inoperative.

Certain other precautions are required when it is necessary to tow with the front drive wheels lifted off the road. On Motor Homes equipped with the Power Level System, turn the valve dials, below the instrument panel, to "HOLD" position, thereby making the automatic height valves inoperative on the rear suspension. On Motor Homes not equipped with the optional Power Level System it will be necessary to disconnect the height control valve link arm at the rear suspension control arm (adjacent to the shock absorber stud) on each side of the vehicle (figure 10). Raising front of vehicle so front wheels are four inches off the ground will provide about five-inch ground clearance at the rear when towing.

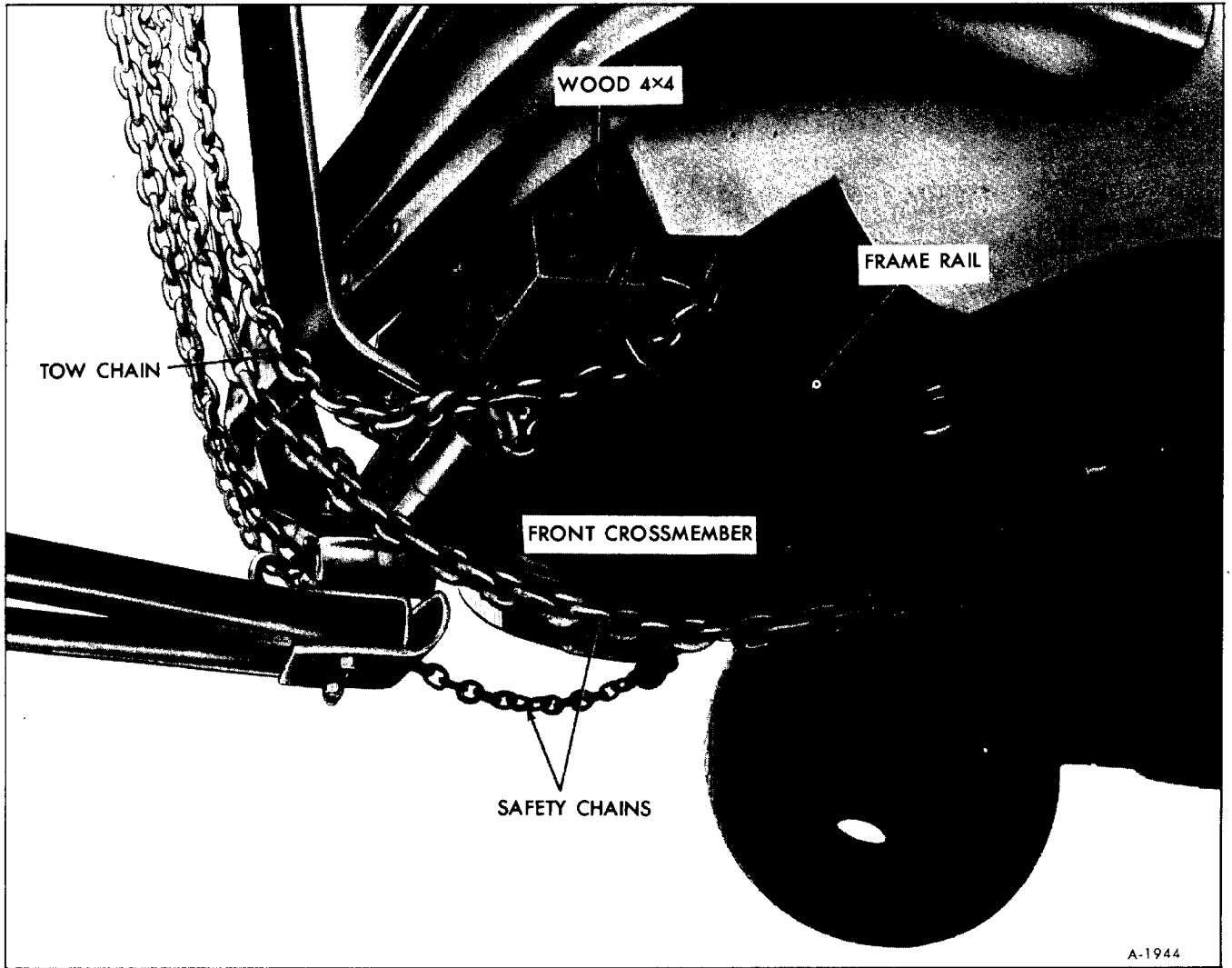

A-1944

Figure 9—Typical Towing Hook-up

## TOWING AT REAR

It is not recommended that vehicle be towed with the rear raised as this could result in suspension or crossmember damage.

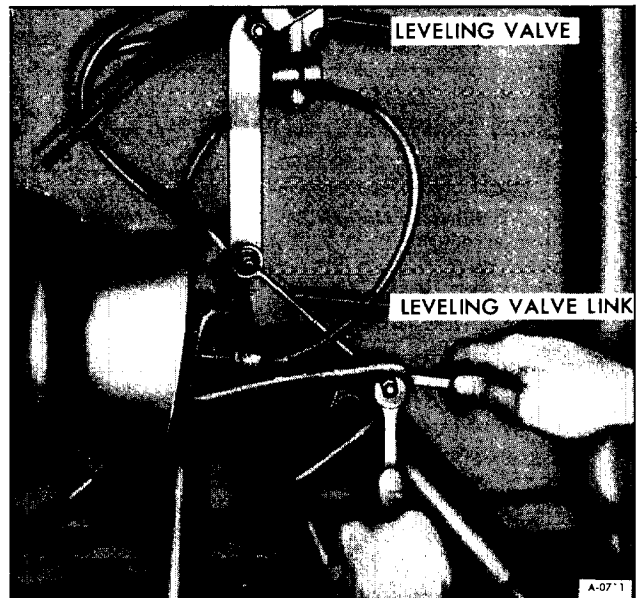

A-071

Figure 10—Disconnecting Leveling Valve Link Arm

# ENGINE, CHASSIS, AND BODY MAINTENANCE SCHEDULE

## LUBE AND GENERAL MAINTENANCE

WHEN TO PERFORM SERVICES (Months or Miles, Whichever Occurs First)	Item No.	SERVICES (For Details, See Numbered Paragraphs)
Every 3 months or 3,000 miles	1	Chassis Lubrication
	2	Engine Oil
Every 6 months or 6,000 miles	3	Fluid Levels
	4	Air Conditioning System
	5	Air Compressor Air Filter
Every 6,000 miles (Check wheel nut torque after 1st 500 miles)	6	Wheel and Tires
At 1st oil change and then every 2nd	7	Engine Oil Filter
Every 12 months or 12,000 miles	8	Automatic Transmission and Final Drive
	9	Cooling System
Every 24,000 miles	10	Rear Wheel Bearings
	11	Final Drive Boots & Output Shaft Seals

## SAFETY MAINTENANCE

Every 6 months or 6,000 miles	12	Brakes and Power Steering
	13	Exhaust System
	14	Drive Belts
	15	Suspension and Steering
	16	Owner Safety Checks
Every 6,000 miles	17	Disc Brakes
Every 12 months or 12,000 miles <sup>1</sup>	18	Drum Brakes and Parking Brake
	19	Throttle Linkage
	20	Headlights
	21	Underbody
	22	Bumpers

## EMISSION CONTROL MAINTENANCE

At 1st 6 months or 6,000 miles – then at 12 months/12,000 mile intervals	23	Thermostatically Controlled Air Cleaner
	24	Carburetor Choke
	25	Timing, Dwell, Carb. Idle, Distributor & Coil
At 1st 6 months or 6,000 miles	26	Carburetor & Intake Manifold Mounting
Every 6,000 miles	27	Spark Plugs (When using leaded fuels)
Every 12 months or 12,000 miles	28	Thermal Vacuum Switch and Hoses
	29	Carburetor Fuel Filter
	30	PCV System
	31	Air Cleaner Element
	32	Spark Plugs and Ignition Coil Wires
Every 24 months or 24,000 miles	33	Engine Compression
	34	ECS System
	35	Fuel Cap. Tanks and Lines

# EXPLANATION OF MAINTENANCE SCHEDULE

Presented below is a brief explanation of each of the services listed in the preceding Maintenance Schedule.

Vehicle operation under conditions such as heavy dust, continuous short trips, use of other than unleaded or low lead fuels or pulling trailers, is not considered normal use and therefore more frequent maintenance will be required. Such additional maintenance requirements are included where applicable.

## LUBE AND GENERAL MAINTENANCE

### ITEM

### NO. SERVICES

**1 CHASSIS**—Lubricate all grease fittings in front and rear suspension and steering linkage. Also lubricate transmission shift linkage, brake pedal spring, parking brake cable guides and linkage.

**2 ENGINE OIL**—Change each 3 months or 3,000 miles, whichever occurs first.

**3 FLUID LEVELS**—Check level of fluid in brake master cylinder, power steering pump, all batteries, engine, final drive, transmission, and windshield washer. The engine coolant should be checked for proper level and freeze protection to at least -35°F., or to the lowest temperature expected during the period of vehicle operation. Proper engine coolant also provides corrosion protection.

Any significant fluid loss in any of these systems or units could mean that a malfunction is developing and corrective action should be taken immediately. A low fluid level in the brake master cylinder front reservoir could also be an indicator that the disc brake pads need replacing.

**4 AIR CONDITIONING**—Check condition of air conditioning system hoses and refrigerant charge at sight glass. Replace hoses and/or refrigerant if need is indicated.

**5 AIR COMPRESSOR**—Filter should be washed with soap and water solution or replaced.

**6 WHEELS AND TIRES**—Have wheel-nut torque checked after 1st 500 miles and 500 miles after every wheel replacement thereafter. Check tires for excessive wear, nails, glass, cuts or other damage. Make certain wheels are not bent or cracked. Uneven or abnormal tire wear may indicate the need for alignment service. Tire inflation should be checked

monthly or more often if visual inspection indicates a need and after each tire rotation. Adjust pressure if required, as shown on tire placard on glove box door.

**7 ENGINE OIL FILTER**—Replace at the first oil change and every 2nd oil change thereafter.

**8 AUTOMATIC TRANSMISSION FLUID AND FINAL DRIVE LUBRICANT**—Change the transmission fluid and filter; change final drive lubricant.

**9 COOLING SYSTEM**—At 12-month or 12,000-mile intervals, wash radiator cap and filler neck with clean water, pressure test system and radiator cap for proper pressure holding capacity. (Tighten hose clamps and inspect condition of all cooling and heater hoses.) Replace hoses every 24 months or 24,000 miles or earlier if checked, swollen or otherwise deteriorated.

Also each 12 months or 12,000 miles, clean exterior of radiator core and air conditioning condenser. Every 24 months or 24,000 miles, drain, flush, and refill the cooling system with a new coolant solution.

**10 WHEEL BEARINGS**—Clean and repack rear wheel bearings with a lubricant as specified in the "Recommended Fluids and Lubricants" chart.

**11 FINAL DRIVE AXLE BOOTS AND OUTPUT SHAFT SEALS**—Check for damaged, torn or leaking boots on drive axles and for leaking output shaft seal. Replace defective parts as necessary.

## SAFETY MAINTENANCE

**12 BRAKES AND POWER STEERING**—Check lines and hoses for proper attachment, leaks, cracks, chafing, deterioration, etc. Any questionable parts noted should be replaced or repaired immediately. When abrasion or wear is evident on lines or hoses, the cause must be corrected.

**13 EXHAUST SYSTEM**—Check complete exhaust system and nearby body areas of vehicle engine and motor-generator system for broken, damaged, missing or mispositioned parts, open seams, holes, loose connections or other deterioration which could permit exhaust fumes to seep into the passenger compartment. Dust or water in the passenger compartment may be an indication of a problem in one of these areas. Any defects should be corrected immediately. To help ensure continued integrity, exhaust system pipes rearward of the muffler must be replaced whenever a new muffler is installed.

**14 ENGINE DRIVE BELTS**—Check belts driving fan, Delcotron, power steering pump and air conditioning compressor for cracks, fraying, wear and tension. Adjust or replace as necessary.

It is recommended that belts be replaced every 24 months or 24,000 miles, whichever occurs first.

**15 SUSPENSION AND STEERING**—Check for damaged, loose or missing parts, or parts showing visible signs of excessive wear or lack of lubrication in front and rear suspension and steering system.

**16 SAFETY CHECKS TO BE PERFORMED BY OWNER**—The maintenance schedule in the Operating Manual lists several items the owner should check and have repaired if not functioning properly.

**17 DISC BRAKES**—Check brake pads and condition of rotors while wheels are removed during tire rotation.

**18 DRUM BRAKES AND PARKING BRAKE**—Check drum brake linings and other internal brake components at rear wheels (drums, wheel cylinders, etc.). Parking brake adjustment also should be checked for drag and lubricated at every chassis lube period.

**NOTE:** More frequent checks should be made if driving conditions and habits result in frequent brake application.

**19 THROTTLE LINKAGE**—Check for damaged or missing parts, interference or binding.

**20 HEADLIGHTS**—Check for proper aim. Correct as necessary.

**21 UNDERBODY**—In geographic areas using a heavy concentration of road salt or other corrosive materials for snow removal or road dust control, flush and inspect the complete underside of the vehicle at least once each year, preferably after a winter's exposure. Particular attention should be given to cleaning out underbody members where dirt and other foreign materials may have collected.

**22 BUMPERS**—Check the front and rear bumper systems at 12-month/12,000-mile intervals to be sure the impact protection and clearance originally designed into the system remains in a state of full readiness. It also should be checked whenever there is obvious bumper misalignment, or whenever the vehicle has been involved in a significant collision in which the bumper was struck, even when no damage to the bumper system can be seen.

## EMISSION CONTROL MAINTENANCE

**23 THERMOSTATICALLY CONTROLLED AIR CLEANER**—Inspect installation to make certain that all hoses and ducts are connected and correctly installed. Also check valve for proper operation.

**24 CARBURETOR CHOKE**—Check choke mechanism for free operation. Any binding condition which may have developed due to petroleum gum formation on the choke shaft or from damage should be corrected.

**25 TIMING, DWELL, CARBURETOR IDLE, DISTRIBUTOR AND COIL**—Adjust ignition timing, dwell and carburetor idle speed accurately (following the specifications shown on the label attached to engine rocker cover) at the first 6 months or 6,000 miles of operation then at 12 month or 12,000 miles. Then at 12 month or 12,000 mile intervals. Adjustment must be made with test equipment known to be accurate.

Replace distributor points every 12 months or 12,000 miles and replace cam lubricator every 24 months or 24,000 miles. In addition, carefully inspect the interior and exterior of the distributor cap, distributor rotor and coil for cracks, carbon tracking, and terminal corrosion. Clean or replace as necessary at 24-month/24,000 mile intervals to prevent misfiring and/or deterioration.

Proper functioning of the carburetor is particularly essential to control of emissions. Correct mixtures for emission compliance and idle quality have been preset by GMC Truck. Plastic idle mixture limiters have been installed on the idle mixture screws to discourage unauthorized adjustment. These idle limiters are not to be removed unless some major carburetor repair or replacement which affects the idle screw adjustment has been necessary.

At 12 months or 12,000 mile intervals or in case of major carburetor overhaul, or when poor idle quality exists, the idle mixture should be adjusted by use of a CO meter when an accurate meter is available, or the alternate mechanical method should be used to adjust idle mixture (See SECTION 6M).

**26 CARBURETOR AND INTAKE MANIFOLD MOUNTING**—Torque carburetor and intake manifold attaching bolts and/or nuts at first 6 months or 6,000 miles of vehicle operation.

**27 SPARK PLUGS**—Replace at 6,000 mile intervals when operating with leaded fuels, or at 12,000-mile intervals when using unleaded fuels. Use of leaded fuels results in lead deposits on spark plugs and can cause misfiring at mileages less than 12,000 miles. Where misfiring occurs prior to 6,000 miles, spark plugs in good condition can often be cleaned, tested, and reinstalled in an engine with acceptable results.

**28 THERMAL VACUUM SWITCH AND HOSES**—Check for proper operation. A malfunctioning switch must be replaced. Check hoses for proper connection, cracking, abrasion or deterioration and replace as necessary.

**29 CARBURETOR FUEL FILTER**—Replace filter at 12-month/12,000-mile intervals or more frequently if clogged.

**30 POSITIVE CRANKCASE VENTILATION SYSTEM (PCV)**—Check system for satisfactory operation at 12-month or 12,000-mile intervals using a tester, and clean filter. Replace the PCV valve at 24-month or 24,000-mile intervals and blow out PCV valve hose with compressed air. The PCV valve should be replaced at 12-month or 12,000-mile intervals when the vehicle is used in operations involving heavy dust, extensive idling, trailer pulling, and short trip use at freezing temperatures where engine does not become thoroughly warmed-up.

**31 AIR CLEANER ELEMENT**—Replace the engine air cleaner element under normal operating conditions every 12,000 miles. Operation of vehicle in dusty areas will necessitate more frequent element replacement.

**CAUTION:** *Do not operate the engine without the air cleaner unless temporary removal is necessary during repair or maintenance of the vehicle. When the air cleaner is removed backfiring can cause fire in the engine compartment.*

**32 SPARK PLUG IGNITION COIL WIRES**—Inspect spark plug and ignition coil wires for evidence of chipping or cracking of exterior insulation and tight fit in the distributor cap and at the spark plugs. Exterior of wires should be cleaned, any evidence of corrosion on ends removed and wire replaced if deteriorated.

**33 ENGINE COMPRESSION**—Test engine cranking compression. If a problem exists, have correction made. Minimum compression recorded in any one cylinder should not be less than 70% of the highest cylinder. For example, if the highest pressure in any one cylinder is 150 lbs., the lowest allowable pressure for any other cylinder would be 105 lbs. ( $150 \times 70\% = 105$ ).

**34 EVAPORATION CONTROL SYSTEM (ECS)**—Check all fuel and vapor lines and hoses for proper connections and correct routing as well as condition. Remove canister(s) and check for cracks or damage. Replace damaged or deteriorated parts as necessary. Replace filter in lower section of canister.

If vehicle is equipped with two canisters, filter is located in the lower canister only.

**35 FUEL CAP, FUEL LINES AND FUEL TANKS**—Inspect the fuel tank cap and lines for damage which could cause leakage. Inspect fuel cap for correct sealing ability and indications of physical damage. Replace any damaged or malfunctioning parts.



## RECOMMENDED FLUIDS AND LUBRICANTS

USAGE	FLUID/LUBRICANT	CAPACITIES
Engine oil	High quality SE oil	5 qts. (6 w/filter)
Power steering systema and pump reservoir. Includes windshield wiper motor	GM power steering fluid Part No. 1050017 – if not available use DEXRON DEXRON II automatic transmission fluid	1 1/2 Qts.
Final drive	SAE-80 or SAE-90 GL-5 gear lubricant (SAE-80 in Canada)	4 Pts.
Brake system and master cylinder	Delco Supreme 11 or, DOT-3 fluid or equivalent	
Transmission shift linkage	Engine oil	
Chassis lubrication	Chassis grease meeting requirements of GM 6031-M	
Transmission	DEXRON or DEXRON II automatic transmission fluid	
Parking brake cables	Chassis grease	
Rear wheel bearings	Chassis grease meeting requirements of GM 6031-M	
Body door hinge pins, hinges and latches at the front access doors, external utilities, generator/storage and LP gas doors. Gas fill door hinge	Engine oil	
Windshield washer solvent	GM Optikleen washer solvent Part No. 1050001 or equivalent	
Energizers (Batteries)	Colorless, odorless, drinking water	
Engine coolant	Mixture of water and a high wuality Ethylene Glycol base type anti-freeze conforming to GM Spec. 1899-M	21 Qts.

**NOTE:** Fluids and lubricants identified with GM part numbers or GM specification numbers may be obtained from your GMC Motor Home Service Outlet.

\* 12 qts. after complete overhaul.

# LUBRICATION DETAILS

## ENGINE

### ENGINE OIL AND FILTER RECOMMENDATIONS

- Use only SE engine oil.
- Refer to "Engine, Chassis and Body Maintenance Schedule" for oil change and filter replacement intervals.

The recommendations in the "Engine, Chassis and Body Maintenance Schedule" apply to the first change as well as subsequent oil changes. The oil change interval for the Motor Home engine is based on the use of SE oils and quality oil filters. Oil change intervals longer than those listed above will seriously reduce engine life and may affect GMC Truck Coach's obligation under the provisions of the New Vehicle Warranty.

A high quality SE oil was installed in the engine at the factory. It is not necessary to change this factory-installed oil prior to the recommended normal change period. However, check the oil level more frequently during the break-in period since higher oil consumption is normal until the piston rings become seated.

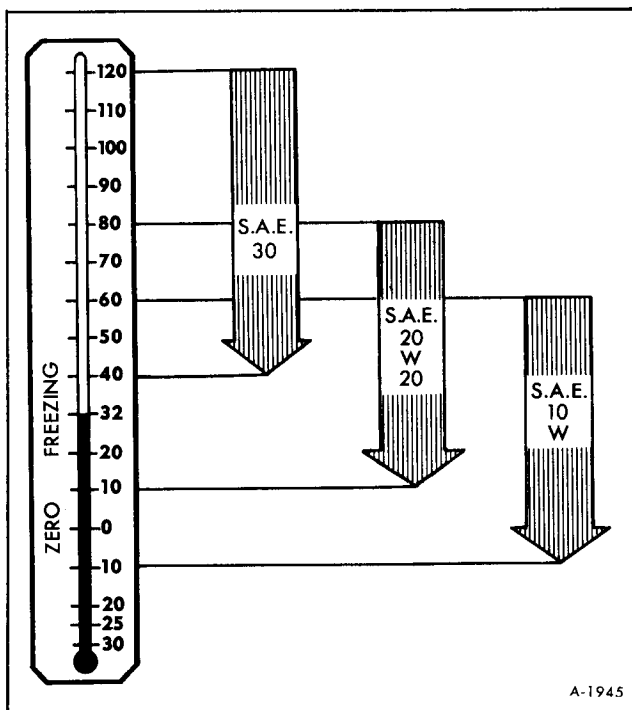

Figure 11-Engine Oil Viscosity Chart

**NOTE:** Non-detergent and other low quality oils are specifically not recommended. Only the use of SE engine oils and proper oil and filter change intervals assure of continued proper lubrication of the Motor Home's engine.

### RECOMMENDED SAE VISCOSITY (FIGURE 11)

- Single grade oils are preferred, however, multi-grades such as SAE 10W-30 or 10W-40 are also acceptable.
- SAE 5W-20 oils are not recommended for sustained high speed driving.
- SAE 5W-30 oils (if available) may be used if extreme low temperatures are anticipated.

### SUPPLEMENTAL ENGINE OIL ADDITIVES

The regular use of supplemental additives is specifically not recommended and will increase operating costs. However, supplemental additives are available that can effectively and economically solve certain specific problems without causing other difficulties. For example, if higher detergency is required to reduce varnish and sludge deposits resulting from some unusual operational difficulty, a thoroughly tested and approved additive—"Super Engine Oil Supplement"—is available at your GMC Motor Home service outlet.

### CHECKING OIL LEVEL

The engine oil should be maintained at the proper level. The best time to check it is before operating the engine or as the last step in a fuel stop. This will allow the normal oil accumulation in the engine to drain back into the crankcase. To check the level, remove the oil level dipstick located inside the left front access door (See figure 12) wipe it clean and reinsert it fully for accurate reading. The oil level dipstick is marked "FULL" and "ADD." (figure 13) The oil level should be maintained within the margin, neither going above the "FULL" line nor below the "ADD" line. Reseat the dipstick firmly after taking the reading. One (1) quart will raise the oil level from "ADD" to "FULL."

**NOTE:** The oil dipstick is also marked "USE SE ENGINE OIL," as a reminder to use only SE oils.

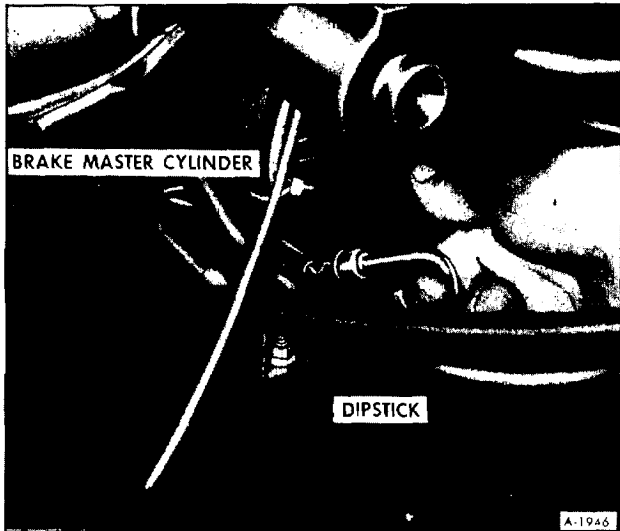

Figure 12—Removing Engine Oil Dipstick

## TRANSMISSION

The transmission dipstick and fill tube is located under the engine access cover on the left side of the engine. (figure 14)

Use only automatic transmission fluids identified with the mark **DEXRON®** or **DEXRON®II**. These fluids have been specially formulated and tested for use in the automatic transmission, and are available from the GMC Motor Home service outlet or local service station.

Check the fluid level at each engine oil change period. To make an accurate fluid level check:

1. Drive Motor Home several miles, making frequent starts and stops, to bring transmission up to normal operating temperature (approx. 180-190° F.).

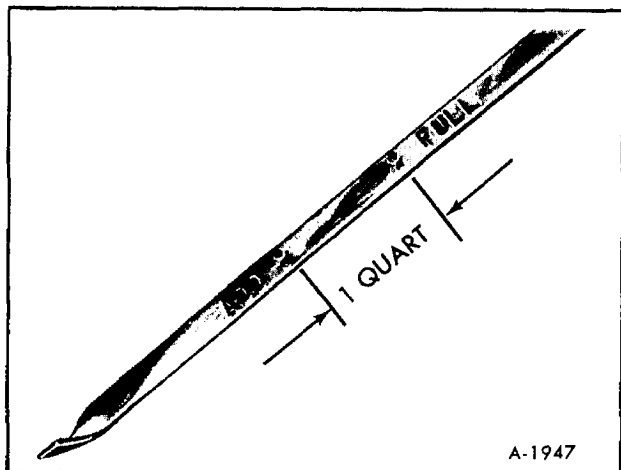

Figure 13—Engine Oil Dipstick

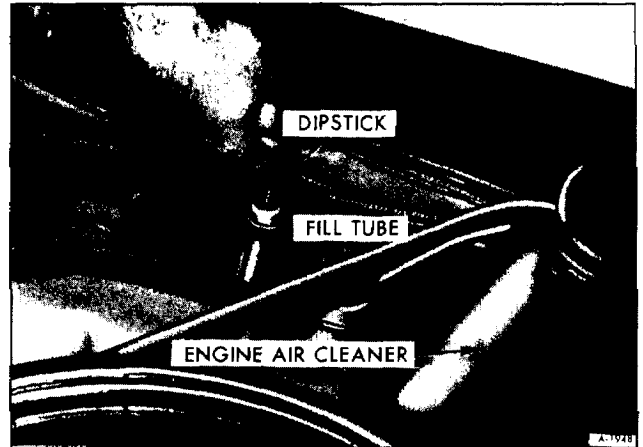

Figure 14—Removing Transmission Dipstick

2. Park Motor Home on a level surface.
3. Apply parking brake.
4. Place selector lever in "PARK" and leave engine running.
5. Open all but the two rear windows, then remove engine cover.
6. Remove dipstick and wipe clean.
7. Reinsert dipstick until cap seats.
8. Remove dipstick and note reading. (figure 15)

If fluid level is at or below the "ADD" mark, add sufficient fluid to raise the level to the "FULL" mark. One pint raises the level from "ADD" to "FULL." Do not overfill. Refer to the Maintenance Chart for servicing schedule.

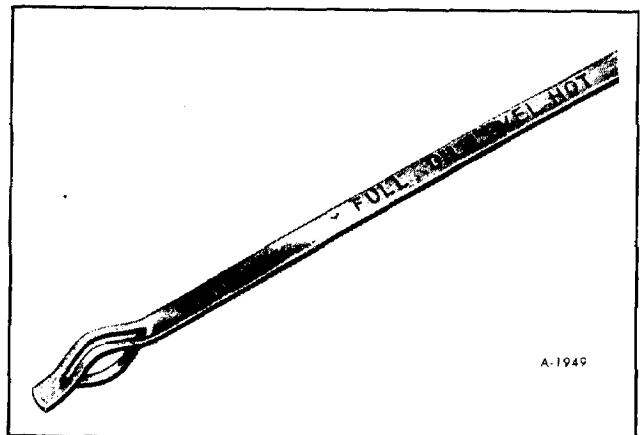

Figure 15—Transmission Dipstick

## TRANSMISSION OIL FILTER REPLACEMENT (FIGURE 16)

**NOTE:** Have a drain pan ready as lubricant will begin to drain as bolts are loosened.

1. Remove (13) bottom pan attaching screws.
2. Remove bottom pan and discard gasket.
3. Remove and discard oil filter assembly.
4. Install new O-ring seal on new filter and intake pipe and filter assembly and install.
5. Using a new pan gasket, install pan. Torque attaching screws to 12 foot-pounds.
6. Add four (4) quarts of DEXRON® or DEXRON® II automatic transmission fluid and check fluid as noted above.

## FINAL DRIVE (FIGURE 17)

### FINAL DRIVE LUBRICANT REPLACEMENT

1. Remove (10) cover attaching bolts. Have a drain pan ready as lubricant will begin to drain as bolts are loosened.
2. Remove cover and allow lubricant to drain. Discard old gasket.
3. Using a new cover gasket, install cover. Torque attaching bolts to 24 foot-pounds. Shield to be bent over breather hole.
4. Add four pints of recommended lubricant

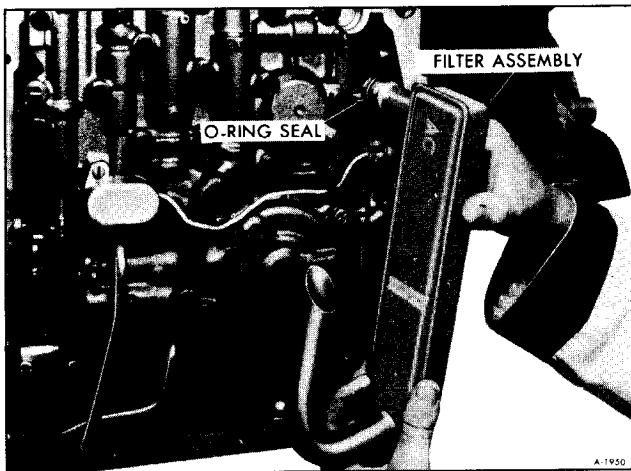

Figure 16—Replacing Transmission Oil Filter

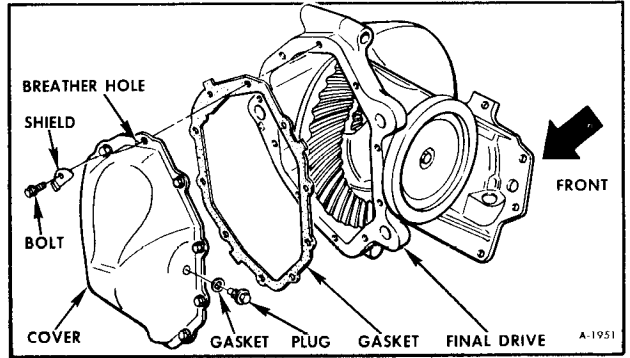

Figure 17—Final Drive Cover Removed

through fill plug hole or fill until lubricant level is at the plug hole.

## STEERING SYSTEM

### POWER STEERING SYSTEM (FIGURE 18)

Check the fluid level in the power steering pump reservoir at each oil change period. This requires the removal of the engine access cover. The reservoir is located near the Delcotron. Add GM Power Steering Fluid (if GM Power Steering Fluid is not available, DEXRON® or DEXRON®II Automatic Transmission Fluid may be used) as necessary to bring level into proper range on the filler cap indicator depending on fluid temperature.

If at operating temperature (approx. 150° F. -hot to the touch) fluid should be between "HOT" and "COLD" marks. If at room temperature (approx. 70° F.) fluid should be between "ADD" and "COLD" marks. The fluid does not require periodic changing.

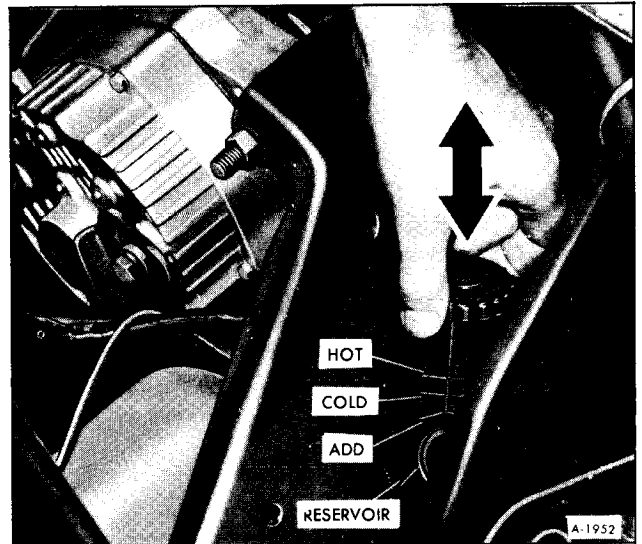

Figure 18—Checking Power Steering Fluid Level

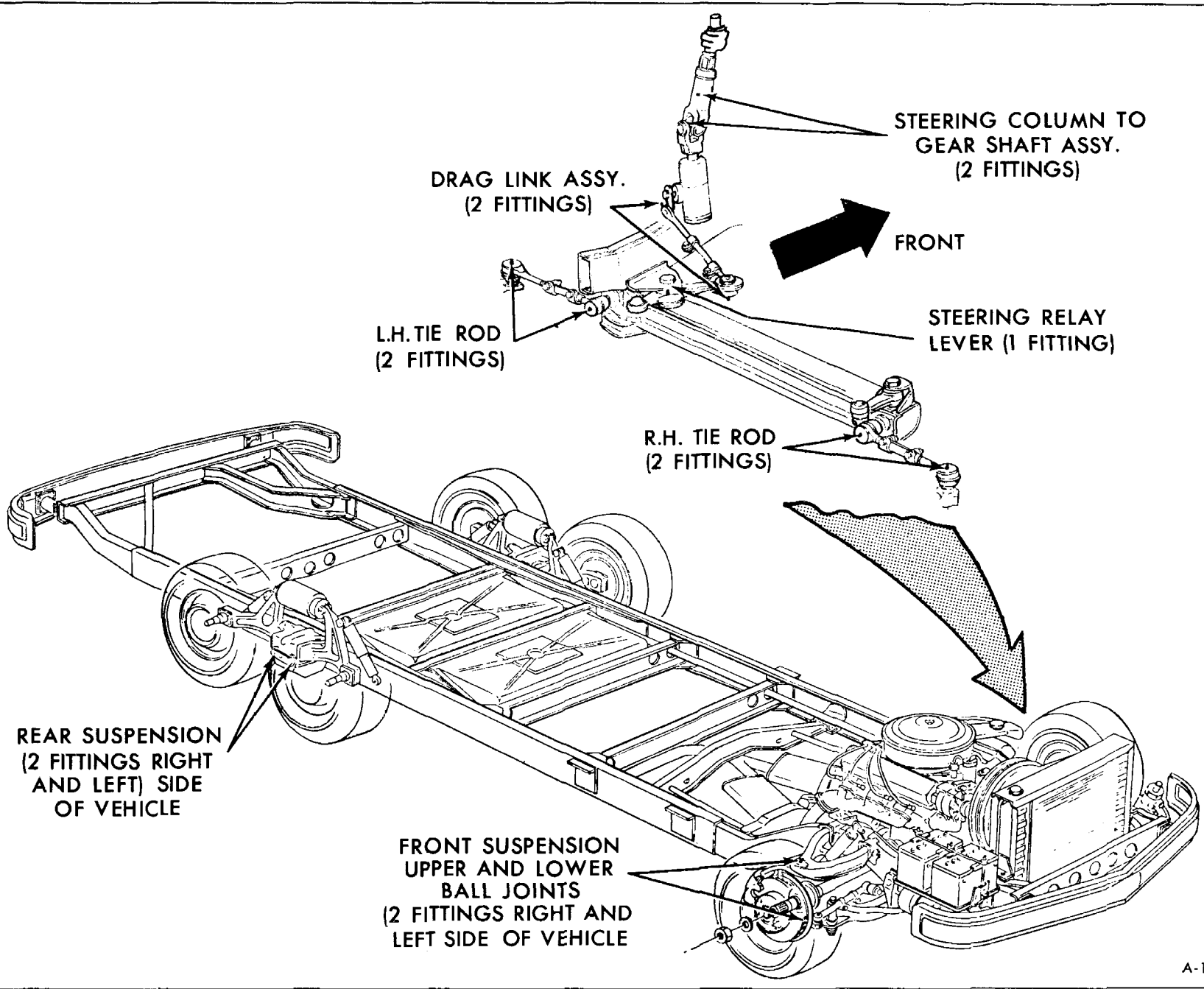

Figure 19-Location of Chassis Lubrication Fittings

## STEERING LINKAGE (FIGURE 19)

The steering linkage (tie rods) and suspension should be lubricated, using a water resistant E.P. Chassis Lubricant that meets GM Specification 6031-M, at every oil change. Seals should be checked for damage.

## BRAKE SYSTEM

### BRAKE MASTER CYLINDER (FIGURE 20)

The master cylinder is located behind the left-side access door on the front of the vehicle. The fluid level in the master cylinder should be checked at each oil change. Wipe off the brake cylinder filler cap and unsnap the retainer. A low fluid level in the front brake master cylinder reservoir could be an indicator that the disc brake pads need replacing. The fluid level must be maintained at 1/4-inch below the top of each reservoir with Delco Supreme No. 11 or DOT-3 Brake Fluid or equivalent. When replacing the cap be sure to fasten the retainer securely, taking care not to let dirt enter the reservoirs.



Figure 20—Checking Brake Master Cylinder

### BLEEDING BRAKES

The need for bleeding brakes is generally indicated by springy, spongy pedal action. Pressure bleeding equipment must be used and a definite bleeding sequence and procedure must be followed. For proper bleeding sequence see BRAKES (SECTION 5) of this manual.

## WINTERIZATION AND VEHICLE STORAGE

Winterization and vehicle storage are essential service functions which must be performed on GMC Motor Homes. Details on these items are covered in SECTION 24A "Periodic Maintenance and Lubrication"



# SECTION 1

## BODY, HEATING AND AIR CONDITIONING

This section includes the following:

SUBJECT	PAGE NO.
Body .....	1-1
Air Conditioning System (Includes Heating).....	1-23
Heating System (Without Air Conditioning).....	1-86

### BODY

Contents of this section are listed below:

SUBJECT	PAGE NO.
General Information .....	1-1
Key Information .....	1-1
Exterior Maintenance .....	1-2
Interior Maintenance .....	1-2
Dust and Water Leaks .....	1-3
Painting .....	1-4
Glass.....	1-5
Windshield Wiper System .....	1-9
Entrance Door .....	1-12
Access Doors .....	1-15
Lap Belt Maintenance .....	1-16
Floor.....	1-16
Fiberglass Repair .....	1-18
Sheet Metal Repair .....	1-19
Seats .....	1-19
Mirrors and Sun Visor .....	1-20
Radiator Grille.....	1-21
End Cap .....	1-21
Special Tools .....	1-22

### GENERAL INFORMATION

The body of the vehicle is constructed of aluminum and fiberglass with a wood floor. Extruded aluminum ribs and struts are welded together to form a cage-like framework. The exterior skin is then bonded directly to the framework.

Both front and rear end caps are fiberglass; and the lower side panels, below the belt line, are fiber-

glass. The side panels, above the belt line, are sheet aluminum. The main roof panel is also sheet aluminum.

The roof and side panels are bonded directly to the aluminum framing. Pop rivets are then used to secure the panels where the roof and side panels are joined and rivets are also used at the belt line.

### KEY INFORMATION

All models have ignition and glove compartment lock cylinders incorporating coded keyways and

keys. The code letter is located on the key shank and the code number is stamped on the knock-out por-

tion of the key head. These numbers identify the locks in which the keys are used and are required when ordering or making new keys.

The other keys used on the vehicle have a metal disc secured to the keys. This number should be recorded and the disc destroyed as this number will be needed when ordering or making new keys.

Notch dept information will be provided, on current production keys, upon request through the manufacturer of your key cutting equipment or his locksmith association. Also he will be able to furnish a conversion package for your cutter, if required, for grinding new keys.

## EXTERIOR MAINTENANCE

Entire vehicle should be regularly inspected for condition of paint and for corrosion damage, with particular attention given to chrome. Inspection should be made more frequently in freezing weather due to the corrosive effect of road deicing materials (salt, calcium chloride, etc.) on metal. If inspection discloses any evidences of corrosion, paint failure, or bare metal, corrective measures as outlined under "Painting" (later in this section) should be immediately employed.

Body painted surfaces and chrome plating should be protected by a coating of wax, applied at regular intervals. Periods between applications should be sufficiently short to assure continuous protection of the finish; 30 days after delivery, and at least once a

year thereafter. Any good body wax can be used for both painted and chrome surfaces. Wax should be applied immediately after vehicle has been cleaned.

**NOTE:** Calcium chloride and other salts, road tar, excretion from insects, ("treesap"), chemicals from factory chimneys and other foreign matter may permanently damage paint and chrome. Frequent, regular washing and a thorough cleaning after exposure is recommended to prevent damage by these substances. Use either cold or lukewarm water. Never wash vehicle in direct rays of the sun and always wait until painted surfaces have cooled.

## INTERIOR MAINTENANCE

Dust and loose dirt that accumulate on interior fabric trim should be removed frequently with a vacuum cleaner, whisk broom or soft brush. Vinyl or leather trim should be wiped clean with a damp cloth. Normal cleanable trim soilage, spots or stains can be cleaned with the proper use of trim cleaners available through General Motors Dealers or other reputable supply outlets.

**IMPORTANT:** Do not use commercial paint, chrome or glass cleaners on interior bright trim or painted surfaces. If cleaning is required, lukewarm water and a neutral soap may be used.

Before attempting to remove spots or stains from upholstery, determine as accurately as possible the nature and age of the spot or stain. Some spots or stains can be removed satisfactorily with water or mild soap solution (refer to "Removal of Specific Stains" later in this section). For best results, spots or stains should be removed as soon as possible.

Some types of stains or soilage such as lipsticks, some inks, certain types of grease, mustard, etc., are extremely difficult and, in some cases, impossible to completely remove. When cleaning this type of stain

or soilage, care must be taken not to enlarge the soiled area. It is sometimes more desirable to have a small stain than an enlarged stain as a result of attempted cleaning.

**CAUTION:** *When cleaning interior do not use volatile cleaning solvents such as: acetone, lacquer thinners, enamel reducers, nail polish removers; or such cleaning materials as laundry soaps, bleaches or reducing agents (except as noted in the instructions on "Cleaning Fabrics" and "Removal of Specific Stains.") Never use carbon tetrachloride, gasoline, or naphtha for any cleaning purpose. The above materials may be toxic or flammable, or may cause damage to interior.*

## INTERIOR GLASS

The interior glass surface should be cleaned on a periodic basis for continued good visibility. A commercial household glass cleaning agent containing ammonia will remove normal tobacco smoke and



dust films sometimes caused by ingredients used in vinyls, plastics, or other interior trim materials.

## CLEANING FABRICS

**IMPORTANT:** Be sure vehicle is well ventilated while using the following cleaning agents. Follow manufacturer's recommendations in using such products.

### CLEANING FABRICS WITH CLEANING FLUID

This type of cleaner should be used for cleaning stains containing grease, oil, or fats. Excess stain should be gently scraped off trim with a clean dull knife or scraper. Use very little cleaner, light pressure, and clean cloths (preferably cheesecloth). Cleaning action with cloth should be from outside of stain towards center and constantly changing to a clean section of cloth. When stain is cleaned from fabric, immediately wipe area briskly with a clean absorbent towel or cheesecloth to help dry area and prevent a cleaning ring. If ring forms, immediately clean entire area or panel section of the trim assembly.

**NOTE:** Sometimes a difficult spot may require a second application of cleaning fluid followed immediately by a soft brush to completely remove the spot.

### CLEANING FABRICS WITH DETERGENT FOAM CLEANERS

This type of cleaner is excellent for cleaning general soilage from fabrics and for cleaning a panel section where a minor cleaning ring may be left from spot cleaning. Vacuum area to remove excess loose dirt. Always clean at least a full trim panel or section of trim. Mask adjacent trim along stitch or weld lines. Mix detergent type foam cleaners in strict accordance with directions on label of container. Use foam only on a clean sponge or soft bristle brush—Do not wet fabric excessively or rub harshly with brush. Wipe clean with a slightly damp absorbent towel or cloth. Immediately after cleaning fabric, dry fabric

with a dry towel or hair dryer. Rewipe fabric with dry absorbent towel or cloth to restore the luster of the trim and to eliminate any dried residue.

## REMOVAL OF SPECIFIC STAINS

**CANDY—Chocolate,** use cloth soaked in lukewarm water; other than chocolate, use very hot water. Dry if necessary, clean lightly with fabric cleaning fluid.

**CHEWING GUM—Harden** gum with ice cube and scrape off with dull knife. Moisten with fabric cleaning fluid and scrape again.

**FRUIT STAINS, COFFEE, LIQUOR, WINE, SOFT DRINKS, ICE CREAM AND MILK—Wipe** with cloth soaked in cold water. If necessary, clean lightly with fabric cleaning fluid. Soap and water is not recommended as it might set the stain.

**CATSUP—Wipe** with cloth soaked in cool water. If further cleaning is necessary, use a detergent foam cleaner.

**GREASE, OIL, BUTTER, MARGARINE AND CRAYON—Scrap** off excess with dull knife. Use fabric cleaning fluid.

**PASTE OR WAX TYPE SHOE POLISH—Light** application of fabric cleaning fluid.

**TAR—Remove** excess with dull knife, moisten with fabric cleaning fluid, scrape again, rub lightly with additional cleaner.

**BLOOD—Wipe** with clean cloth moistened with cold water. Use no soap.

**URINE—Sponge** stain with lukewarm soap suds from mild neutral soap on clean cloth, rinse with cloth soaked in cold water; saturate cloth with one part household ammonia and five parts water, apply for one minute, rinse with clean, wet cloth.

**VOMITUS—Sponge** with clean cloth dipped in clean, cold water. Wash lightly with lukewarm water and mild neutral soap. If odor persists, treat area with a water-baking soda solution (one teaspoon baking soda to one cup of tepid water). Rub again with cloth and cold water. Finally, if necessary, clean lightly with fabric cleaning fluid.

## DUST AND WATER LEAKS

Test windshield, windows and vehicle under flooring for leaks by spraying water under pressure

against vehicle while assistant inside marks points of leakage, if any exist.

If location of leak has been determined to be around windshield or rear glass, dry surface and apply rubber cement. Apply cement to outside, both between glass and weatherstrip and between weatherstrip and body.

If the leak is around any side window it will be necessary to remove the window and install a new seal.

A quick method for locating many air and water leaks at windshield, backglass, bolt holes, weatherstripping and joints is as follows:

Close all windows and vents, turn air conditioning or heater blower motor to high position and outside air and close doors. Run water over suspected leak area in a small controllable stream and observe area for pressure bubbles.

Water which shows up at a certain place inside vehicle may actually be entering at a point other than where water is found. Back-track path of water to point of entry. Apply body sealing compound over all leak points. If leakage occurs at door opening, check weatherstrip. Seal with rubber cement or replace if necessary. If door does not firmly contact weatherstrip, align door. Refer to "Door Adjustment" later in this section.

## PAINING

Aluminum corrodes just as iron and steel rusts. Under certain conditions aluminum will corrode more rapidly than steel. Inspect body surfaces regularly for corrosion and paint condition.

Only sound parts can be refinished. If corrosion is excessive, replace with new parts. Remove old parts. Refinish all exposed adjacent parts which remain on vehicle. When installing new parts use only zinc or cadmium coated bolts, washers, and nuts.

The instructions which follow cover both aluminum and fiberglass, and both new and old parts.

1. Through cleaning is essential; all corrosion, grease, and other foreign matter must be removed. Solvent cleaning, pressure steam cleaning, wire brushing, and hand sanding methods are recommended.

2. Completely remove old paint by use of organic solvents. Do not use alkaline paint remover on aluminum. If old primer is very difficult to remove and there is no evidence of metal corrosion, old primer may be left on, but all loose paint must be removed.

3. Wipe the entire area to be refinished with cloths saturated with DuPont No. T-3812 reducer (or equivalent). Wipe dry.

4. Treat any scratched or abraded areas with DuPont No. VM-5717 metal conditioner (or equivalent) reduced one (1) part by volume with four (4) parts of water.

a. Apply the above mixture with a sponge or brush and allow to stand approximately three (3) minutes.

b. Wipe area with a damp cloth. Dry thoroughly.

5. Apply a coat of pre-primer (sometimes called wash-primer), preferably by spraying to a uniform and complete coverage coat on all surfaces. This type primer uses a special accelerating agent containing phosphoric acid which produces an excellent bond to metal. AP-10 or A-158 made by M & T Chemical Co., XE-5220 made by Bakelite Corporation, and 818-012 (2 parts), plus T8539 (1 part) made by DuPont, or any equivalent material made by a reputable paint manufacturer should be acceptable. These materials must be used within a few hours after addition of accelerator, therefore, directions of manufacturer should be observed carefully. Apply by spraying. Allow parts to dry.

6. Use a zinc chromate primer such as DuPont No. 63-150 or Pontiac Varnish Company's GMT-434, or any equivalent material made by a reputable manufacturer. Apply primer, preferably by spraying, to a minimum thickness of 0.5 mils. Allow parts to dry.

7. Apply finish coats:

a. For understructure and other parts not requiring color, apply a second coat of DuPont No. 63-150 or Pontiac Varnish Company's GMT-434, or equivalent.

b. To exposed body parts, apply desired color coats in accordance with standard practice.

# GLASS

## WINDSHIELD REPLACEMENT

Windshield glass is retained in the opening by a molded rubber weatherstrip with an insert-type rubber seal as shown in Figure 1. Two glass sections are used in this vehicle.

When replacing a cracked windshield glass, it is very important that the cause of the glass breakage be determined and the condition corrected before a new glass is installed. Otherwise, it is highly possible that a small obstruction or high spot somewhere around the windshield opening will continue to crack or break the newly installed windshield; especially when the strain on the glass caused by the obstruction is increased by such conditions as wind pressures, extremes of temperature, motion of the vehicle, etc.

## REMOVAL

If cracks in glass extend to outer edge of glass, mark body with chalk at these points so that weatherstrip flange opening can be examined later for possible distortion.

Protect the interior finish by placing a protective covering over steering wheel and dash panel. Mask around the windshield opening and lay a suitable cover to protect body.

**WARNING: ALWAYS WEAR HEAVY GLOVES TO PREVENT POSSIBLE INJURY WHEN HANDLING GLASS.**

1. Pry end of insert out of rubber seal with a pointed tool; pull insert completely out of seal.
2. With aid of an assistant to hold glass outside vehicle, push glass forward from inside vehicle.

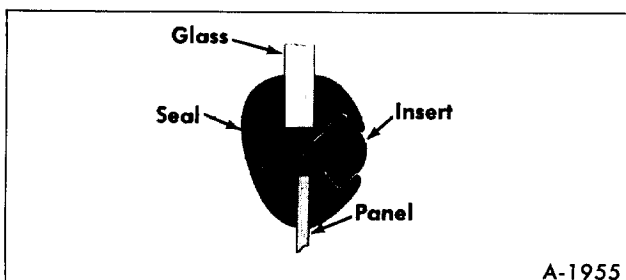

A-1955

Figure 1-Windshield Weatherstrip

## INSPECTION

Due to the expanse and contour of the windshield, it is imperative in the event of a strain break that the windshield opening be thoroughly checked before installing a replacement windshield.

1. Check for the following conditions at the previous marked point of fracture:
  - a. Chipped edges on glass.
  - b. Irregularities in body opening.
  - c. Irregularities in rubber channel weatherstrip.
2. Remove all sealer from flange and body around windshield opening.
3. Check flange area for high spots. Remove all high spots.

## GLASS-TO-OPENING CLEARANCE CHECK

Before installing new glass, check glass opening for proper clearance, using five special spacer blocks (J-9316) as shown in Figure 2. With the aid of an assistant, place blocks around perimeter of new glass, two at bottom and top and one at outer side opening. A 5/16 to 3/8 inch clearance should exist between glass and opening flange. Insert the blocks into gap, then rotate blocks perpendicular to flange surfaces. If all blocks cannot be installed, rework metal flange or grind off edge of glass at the side where block or blocks could not be installed.

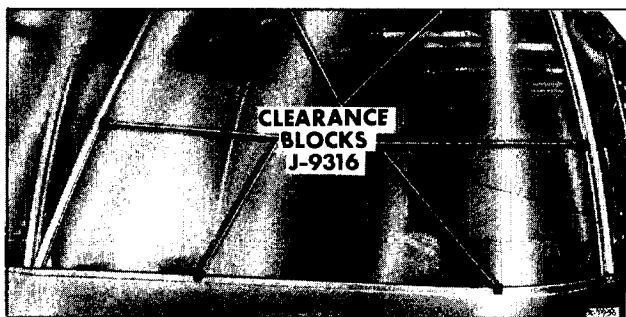

Figure 2-Checking Glass Clearance

**CAUTION:** *DO NOT strike glass against body metal. Chipped edges on the glass can lead to future breaks.*

If glass clearance is too small and glass is to be ground off, place a strip of tape on a line where glass is to be removed. Grind up to edge of tape.

**NOTE:** Add build-up to flange where necessary. Usually the building up to only one side and one-half way around one corner will provide proper glass and seal fit. Taper off ends of build-up to conform to edge of glass, otherwise glass breakage may occur, originating at a point adjacent to the end of flange build-up.

## INSTALLATION (fig. 3)

**NOTE:** If desired, sealing cement can be applied between lip of seal and glass and seal lip at opening flange.

1. Reposition rubber seal on opening flange. Raise new glass to outside of seal; then with hook end of installer tool (J-2189) in glass groove of seal as shown in figure 3, move tool around glass to force outer lip of seal over edge of glass.

2. Thread end of rubber insert through handle and loop of installer tool (fig. 3). Push tool loop and end of insert into groove of seal. Feed in rubber insert, while proceeding around window. Use a hitching movement of tool to avoid elongating insert. If new insert is being used, cut off insert allowing sufficient overlap for a tight joint; then butt into groove.

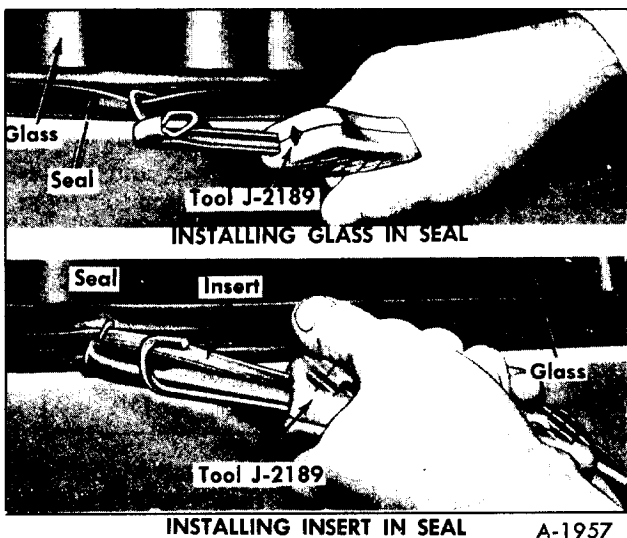

Figure 3—Positioning Seal and Insert

3. Install insert in center vertical seal (2-piece windshield) in same manner previously described in Step 2.

## SIDE WINDOWS

There are two types of windows or sash installed in the vehicle. Either a fixed or sliding window is mounted in an extruded aluminum channel. All side sash uses solid tempered glass. Both the glass and the channel is replaceable.

## SASH ASSEMBLY

### Removal

1. Remove trim mouldings as shown in Figure 4. "A" sash assemblies (sash assemblies in the drivers/-passenger area) will require interior trim panel removal.

2. All sash assemblies are mounted as typically shown in Figure 5. Remove retainers.

3. Tap on the inside channel using a wooden block and rubber mallet.

**NOTE:** The sash assemblies are heavy. Have someone assist by supporting the assembly from the outside.

4. Remove sash assembly.

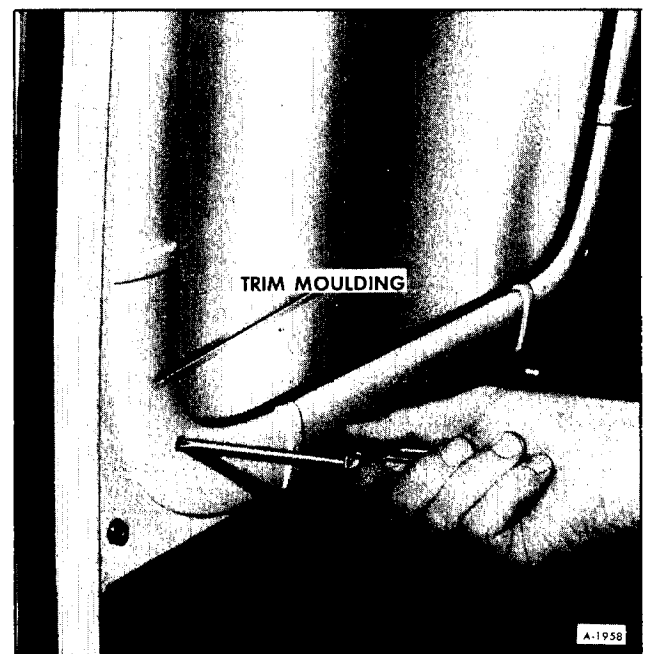

Figure 4—Removing Window Trim Moulding Screws

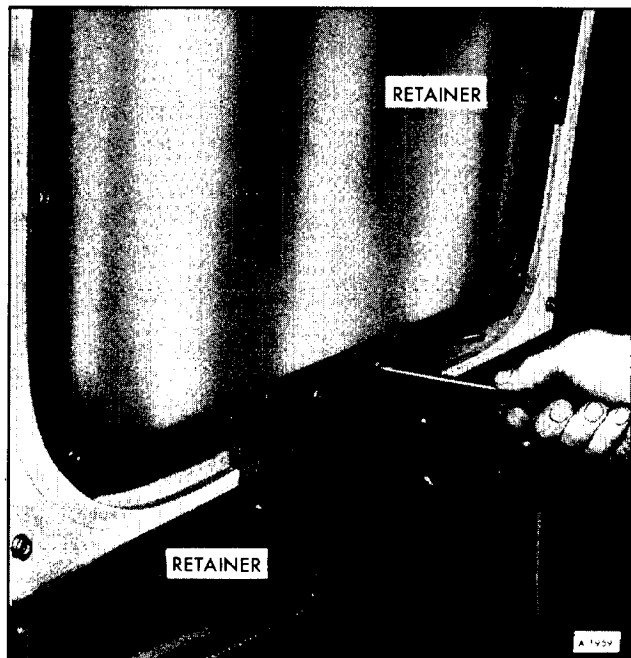

Figure 5—Removing Sash Retainers

5. Remove filler seal from sash assembly.

**Installation**

1. Apply a new filler seal to the sash assembly.

2. Install sash assembly. Position spacers as shown in Figure 6.

**NOTE:** Late model vehicles are not equipped with spacers (figure 6). A 3/16 inch gap should be maintained between sill and sash.

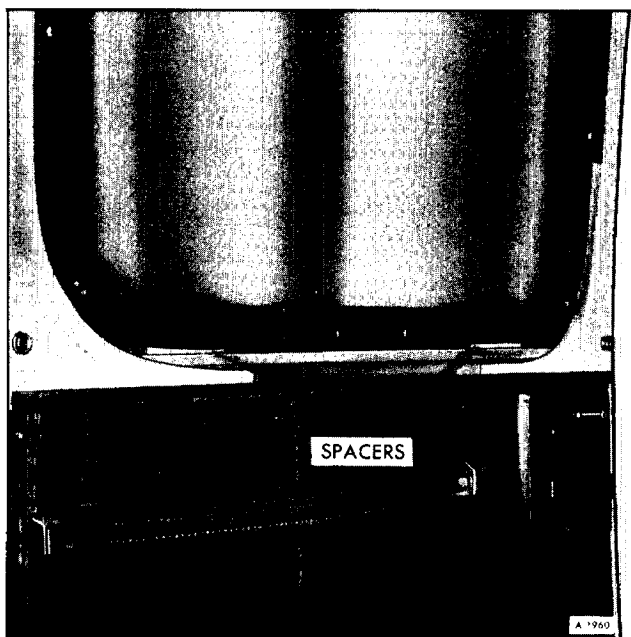

Figure 6—Sash Spacers

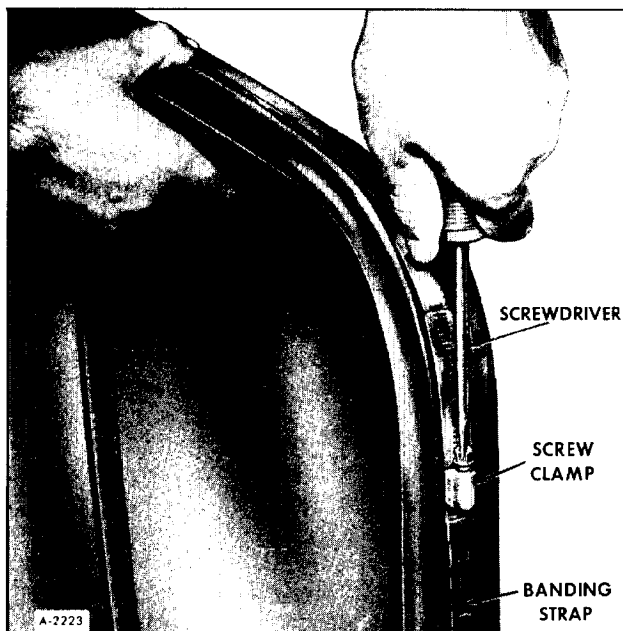

Figure 7—Removing Sash Banding Strap

3. Install retainers.

4. Install panels if removed and install trim mouldings.

**GLASS**

**Removal**

1. Remove sash assembly. Refer to "Sash Assembly - Removal" earlier in this section.

2. Remove the banding strap, if equipped, as shown in figure 7, then disassemble sash assembly as shown in Figure 8.

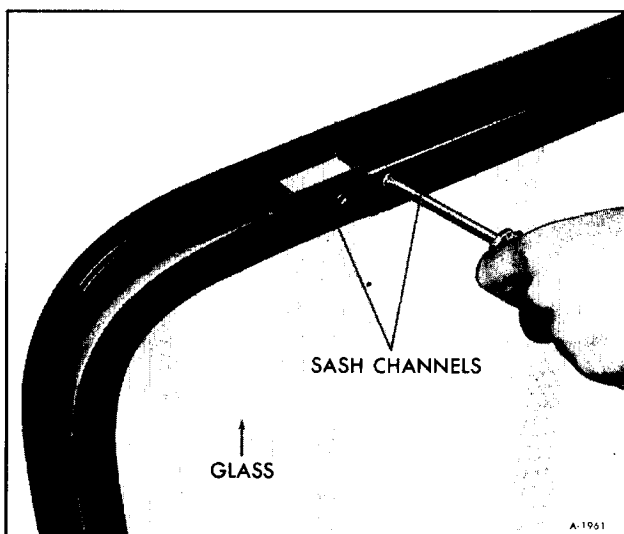

Figure 8—Disassembling Sash

3. Remove glass.
4. Clean glass sash channels thoroughly.

### Installation

1. Install glass into sash.
2. Referring to Figure 7 and 8, assemble sash.
3. Install sash assembly. Refer to "Sash Assembly-Installation" earlier in this section.

## SIDE WINDOW LATCH

### Removal

1. Remove two (2) screws attaching latch to glass.
2. Remove two (2) threaded plastic buttons.
3. Remove latch.

### Installation

1. Install a new seal to latch.
2. Install latch to glass.
3. Replace threaded plastic buttons.

## REAR WINDOW REPLACEMENT

The rear window is retained in the opening by a molded rubber weatherstrip with an insert-type rubber seal.

When replacing a cracked window, it is very important that the cause of the glass breakage be determined and the condition corrected before a new glass is installed. Otherwise it is highly possible that a small obstruction or high spot somewhere around the opening will continue to crack or break the newly installed window; especially when the strain on the glass caused by the obstruction is increased by such conditions as wind pressures, extremes of temperature, motion of vehicle, etc.

## REMOVAL

If crack extends to outer edge of glass, mark body with chalk at this point so that weatherstrip flange

opening can be examined later for possible distortion.

Protect interior finish by using a protective covering mask around window opening and lay a suitable cover to protect body.

**WARNING: ALWAYS WEAR HEAVY GLOVES TO PREVENT POSSIBLE INJURY WHEN HANDLING GLASS.**

1. From inside of vehicle pull insert out of rubber seal by pulling on ring located at top center of window; pull insert out completely.

2. With aid of an assistant to hold glass outside vehicle, push glass out from inside vehicle.

## INSPECTION

Due to the expanse of rear window, it is imperative in the event of a strain break that the window opening be thoroughly checked before installing a replacement window.

1. Check for the following conditions at the previously marked point of fracture.

A. Chipped edges on glass.

B. Irregularities in body opening.

C. Irregularities in rubber channel weatherstrip.

2. Remove all sealer from flange and body around window opening.

3. Check flange area for high spots. All high spots should be removed.

## GLASS-TO-BODY OPENING CLEARANCE

Before installing new glass, check glass opening for proper clearance, using five special spacer blocks (J-9316). With the aid of an assistant, place blocks around perimeter of new glass, two at bottom and top and one at side of opening. A 5/16 to 3/8 inch clearance should exist between glass and opening. Insert the blocks into gap, then rotate blocks perpendicular to flange surfaces. If all blocks cannot be installed, rework flange or grind off edge of glass at the side where block or blocks could not be installed.

**CAUTION:** *Do not strike glass against body. Chipped edges on the glass can lead to future breaks.*

If glass clearance is too small and glass is to be ground off, place a strip of tape on a line where glass is to be removed. Grind up to edge of tape.

**NOTE:** Add build-up to flange where necessary. Usually the building up to only one side and one-half way around one corner will provide proper glass and seal fit. Taper off ends of build-up to conform to edge of glass, otherwise glass breakage may occur, originating at a point adjacent to end of flange build-up.

## INSTALLATION

**NOTE:** If desired, sealing cement can be applied between lip of seal and glass and seal and opening flange.

1. Reposition rubber seal on opening flange. Raise new glass to outside of seal: then with hook end of installer tool (J-2189) in glass groove of seal as shown in Figure 3, move tool around glass to force outer lip of seal over edge of glass.

2. Thread end of rubber insert through handle and loop of installer tool (figure 3). Move installer to middle of insert. Starting at top-center of rubber seal push tool loop and insert into seal groove. Feed in rubber insert, while proceeding around one side of window. Use a hitching movement of tool to avoid elongating insert, position emergency exit pull ring on rubber insert at top center of window. Thread other end of rubber insert through handle and loop of installer tool. Push tool loop and insert into seal groove and position pull ring in place. Feed in rubber insert, while proceeding around other side of window. If new insert is being used, cut off insert allowing sufficient overlap for a tight joint; then butt into groove at bottom of window.

# WINDSHIELD WIPER SYSTEM

## GENERAL INFORMATION

The vehicle is equipped with variable speed hydraulic wipers with washers as standard equipment. A single motor powers both blades.

The wiper motor is mounted to a bracket on the left side of the vehicle in front of the driver's toe board. A lever control on the left side of the instrument panel varies the speed of the wiper blades. The hydraulic motor is powered by power steering fluid from the discharge side of the power steering pump.

## WINDSHIELD WASHER ASSEMBLY REPLACEMENT

The windshield washer reservoir and pump are one unit. The 12 volt pump in the windshield washer reservoir must be replaced with the entire washer assembly.

## REMOVAL

1. Disconnect battery ground cables and then disconnect wire leads (2) to washer motor.

2. Disconnect hose at the rear of the washer reservoir.

3. Lift reservoir out of its bracket and remove it from the vehicle.

## INSTALLATION

1. Position reservoir in its bracket.

2. Install two wires to terminals on motor.

3. Connect hose to back of reservoir.

4. Connect battery ground cables and check for proper operation.

## WASHER NOZZLE ADJUSTMENT

The windshield washer nozzle is located on the end of the wiper arm. The nozzle is retained by the same nut and bolt which attaches the blade to the wiper arm. The nozzle should be parallel with the windshield as shown in Figure 9.

Nozzles are adjustable by loosening the attaching bolt, position nozzle as described above and tighten bolt.

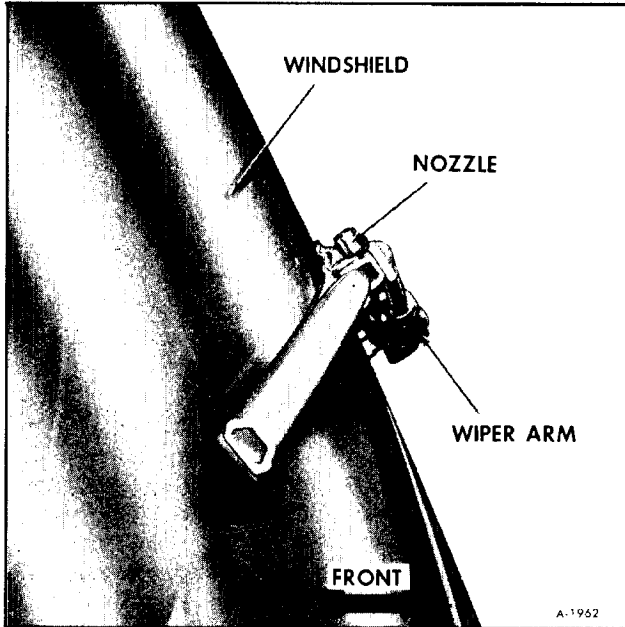

Figure 9-Windshield Washer Nozzle Alignment

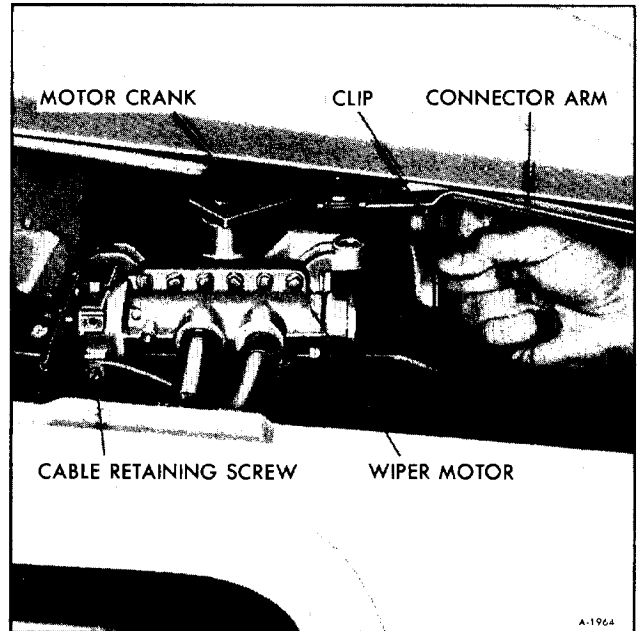

Figure 11-Removing Linkage

## TRANSMISSION PIVOT SHAFT AND LINK REPLACEMENT

### REMOVAL

1. Remove wiper arms from pivot shafts, by removing plastic caps from wiper arm retaining nuts. Remove retaining nuts. Remove wiper arms (See figure 10).

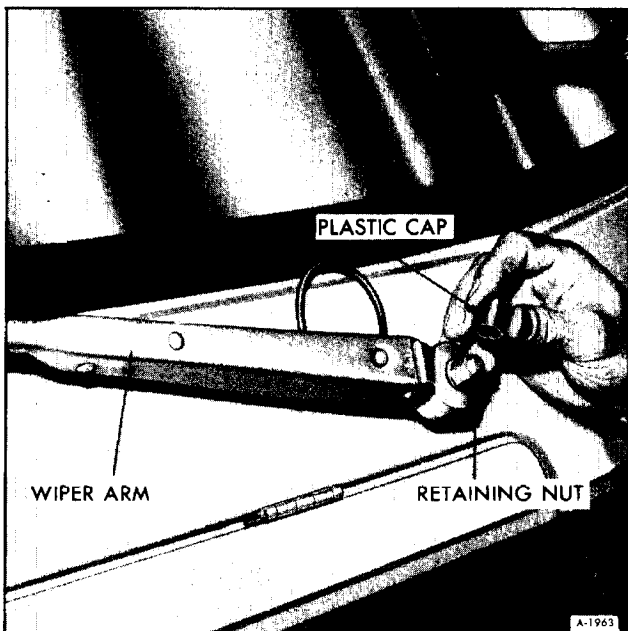

Figure 10-Wiper Arm Removal

2. Remove linkage from wiper motor crank arm by sliding back clip(s) away from motor (figure 11).

3. Remove three bolts from transmission pivot shaft mounting bracket as shown in Figure 12. Remove assembly.

### INSTALLATION

1. Position transmission pivot shaft and secure with three bolts at its mounting bracket.

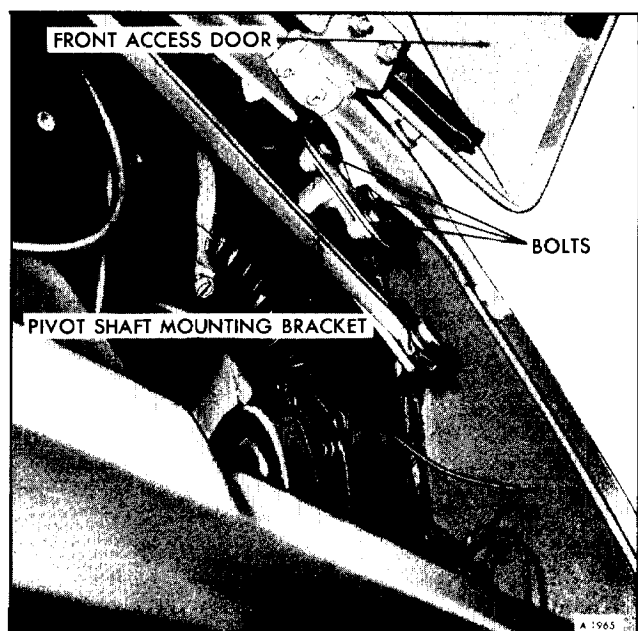

Figure 12-Pivot Shaft Mounting Bracket



2. Install linkage to crank arm on wiper motor.
3. Install wiper arms on pivot shafts.

## WIPER BLADE REPLACEMENT

The wiper blade is retained by the use of a spring type retainer clip in the end of the blade element. When the retainer clip is squeezed together, the blade can be removed by sliding out of the blade assembly.

The blade assembly is retained to the wiper arm by a nut and bolt at the end of the arm. The removal of this nut and bolt will allow removal of the blade assembly and the windshield washer nozzle.

## WIPER ARM ADJUSTMENT

To adjust sweep of blades to provide maximum visibility, turn on wipers, then note sweep of arms.

**CAUTION:** *Do not attempt to manually force wiper arms into position as damage to linkage or motor may occur.*

If necessary, remove arms as follows;

1. Remove plastic protective cap from nut on end of wiper arm.
2. Remove nut from end of wiper arm and remove arm.
3. Arm can be reinstalled in any one of several positions due to serrations on pivot shaft driver head and in wiper arm head.

**NOTE:** Checking blade sweep should be done with the windshield wet.

## WINDSHIELD WIPER MOTOR REPLACEMENT

**NOTE:** The windshield wiper motor is serviced as an assembly. Do not attempt to repair the motor.

## REMOVAL

1. Disconnect hoses (2) at motor and tape end to prevent loss of fluid and entrance of dirt or water into system.
2. Loosen cable retaining screw at bottom of motor and remove pin from arm on motor assembly. See Figure 10.
3. Remove connector arms by sliding back clips and disconnecting arms from the motor assembly.
4. Remove three bolts retaining motor assembly to its bracket.

## INSTALLATION

1. Position wiper motor on bracket and install three retaining bolts.
2. Position connector arms on motor crank arm and secure with slide clips.
3. Insert pin at end of cable assembly and secure with retaining screw on motor assembly.
4. Connect hoses to motor assembly as shown in Figure 13.
5. Check power steering fluid level. Operate wipers on a wet windshield for several minutes. Then recheck power steering fluid level. Also check for fluid leaks. Correct as necessary.

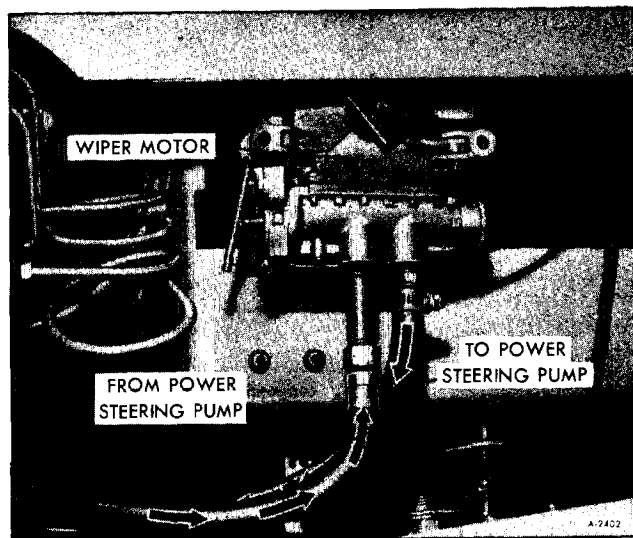

Figure 13—Windshield Wiper Motor

## ENTRANCE DOOR

### ADJUSTMENT

The door may be adjusted vertically by loosening the bolts at both hinges as shown in Figure. 14.

Horizontal adjustment may be made by shimming or removing metal at the shaded area of the hinges as shown in Figure 15.

### DOOR SEAL

The entrance door seal is replaceable. Clean old seal from door frame, apply adhesive to frame then install new seal.

### DOOR REMOVAL

1. Remove four (4) hinge to door frame attaching bolts.
2. Remove door.

### DOOR INSTALLATION

1. Install door.

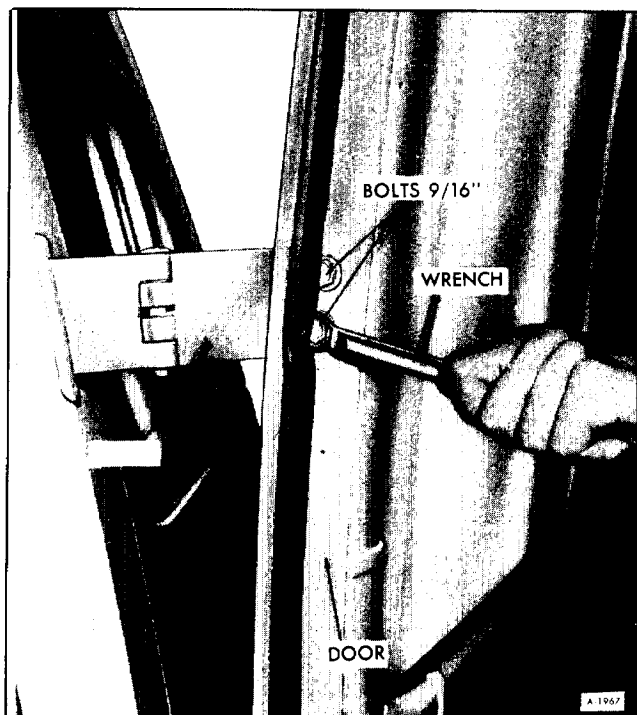

Figure 14—Entrance Door Adjustment-Vertical

2. Install four (4) bolts, torque to 25-30 ft. lbs.
3. Check for leaks and correct as necessary.

### ENTRANCE DOOR LOCK

#### REMOVAL - TYPE I LOCK

1. Remove screws as shown in Figure 16. Remove inner plate and handle assembly.
2. Push lock assembly out from the inside and remove (See figure 17).

#### INSTALLATION - TYPE I LOCK

1. Apply new sealer if required and install lock assembly as shown in Figure 17.
2. Install inner plate and handle assembly.
3. Install screws and tighten securely.

#### REMOVAL - TYPE II LOCK

1. Remove door lock trim panel screws as shown in Figure 18.

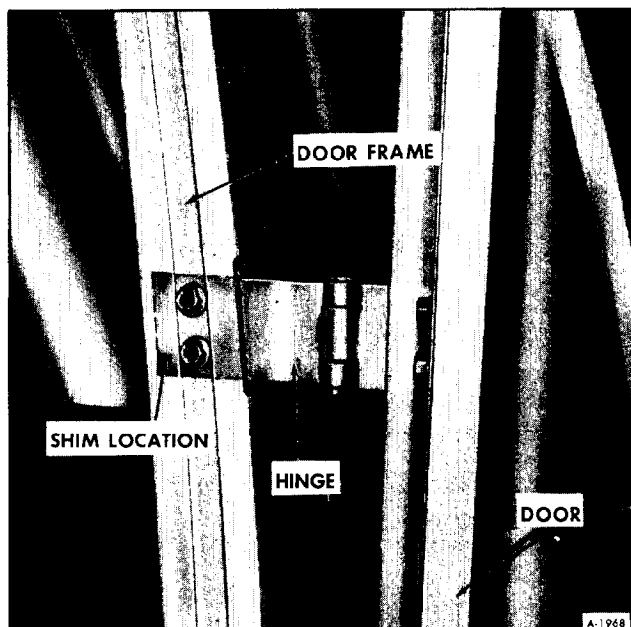

Figure 15—Entrance Door Adjustment-Horizontal

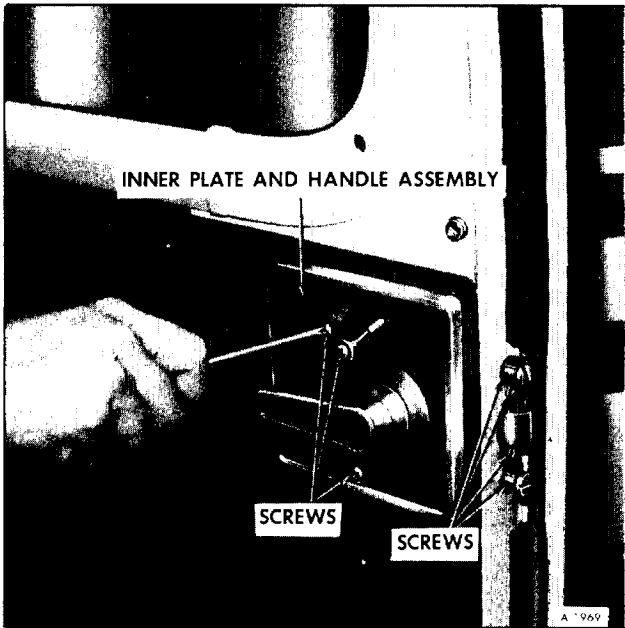

Figure 16-Removing Screws on Type I Lock

2. Remove lock retaining screws.

3. Remove inner plate and handle assembly. Remove door trim panel.

4. Remove screw as shown in Figure 19. Push lock out from the inside.

**INSTALLATION - TYPE II LOCK**

1. Install lock assembly.

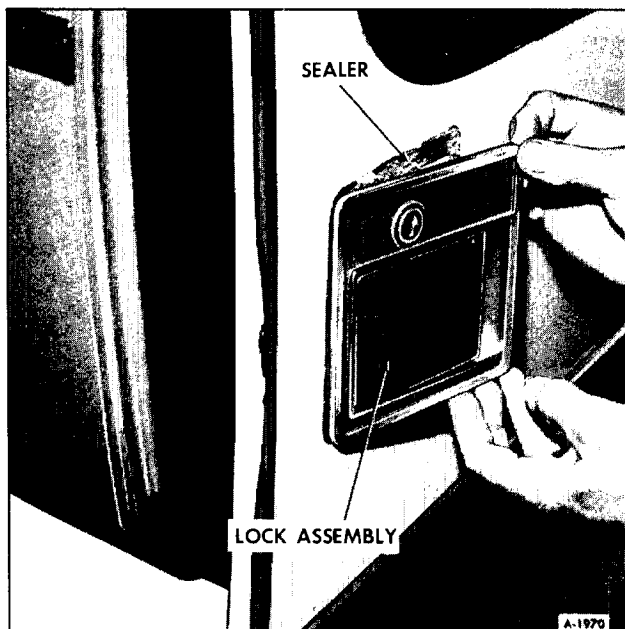

Figure 17-Removing Lock Assembly

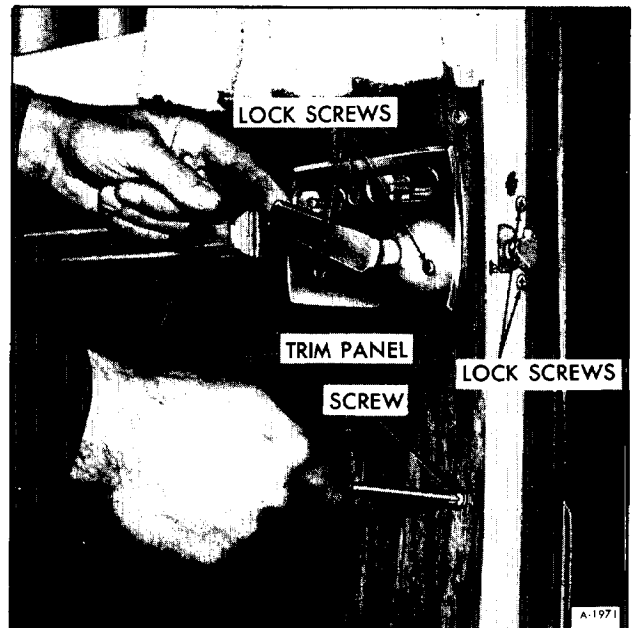

Figure 18-Removing Trim Panel

2. Install door trim panel.

3. Install inner plate and handle assembly.

**REMOVAL - TYPE III LOCK (FIGURE 20)**

1. Remove lower door trim panel.

2. Remove lock button.

3. Remove lower window moulding (figure 4).

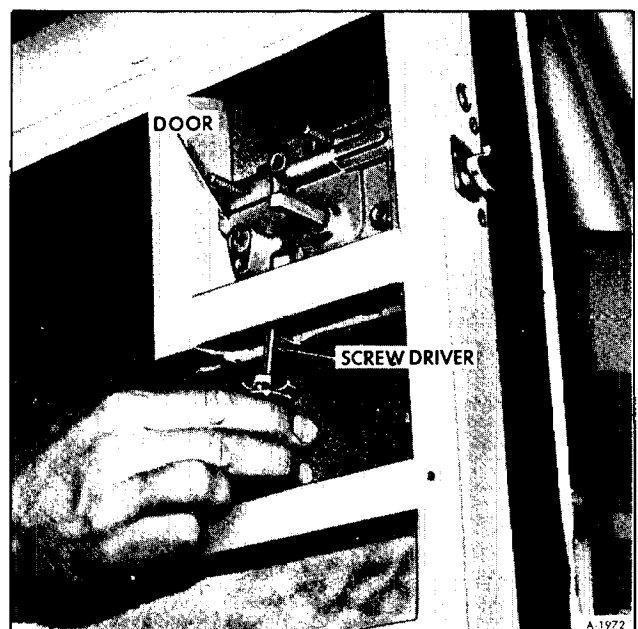

Figure 19-Removing Screw on Type II Lock

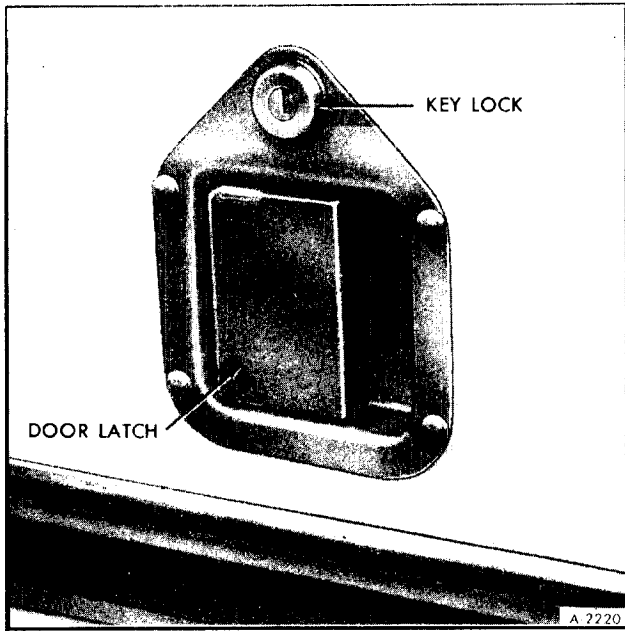

Figure 20--Type III Door Lock

4. Remove upper trim panel and inner handle assembly by loosening screws shown in Figure 21 and removing all other screws. Use care when removing panel to avoid damaging door handle mechanism.

5. Remove cotter pin from handle control rod. Slide rod out of lever at lock mechanism.

6. Remove actuator lever pin and lock button rod clip. See Figure 22.

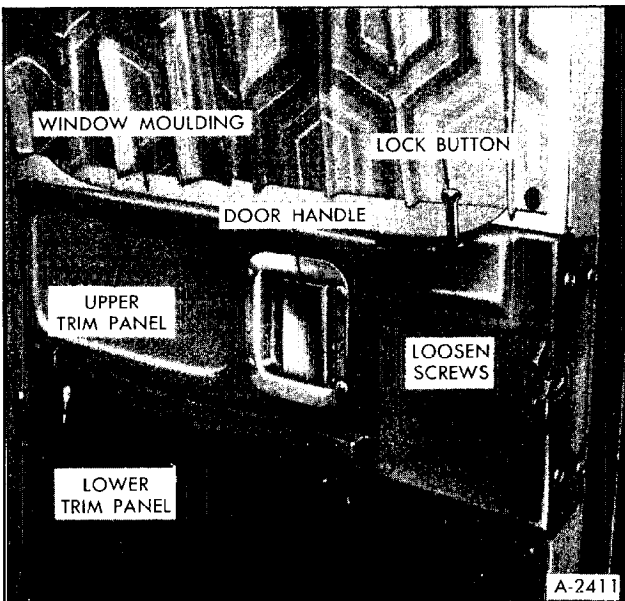

Figure 21--Removing Trim Panels

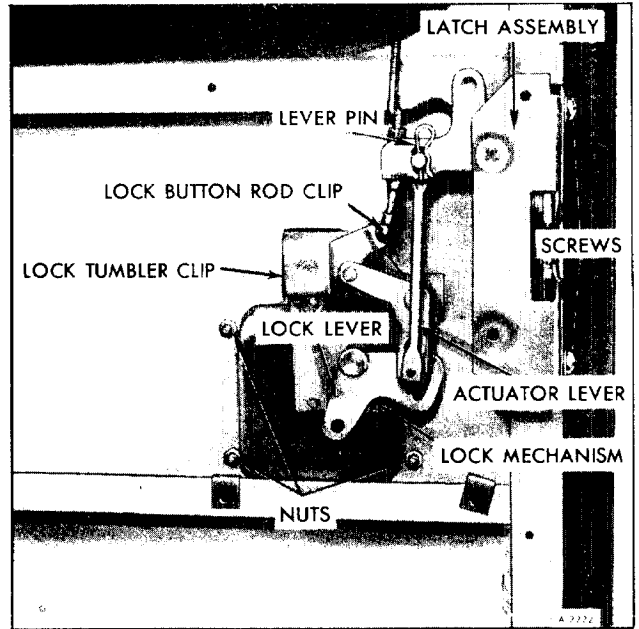

Figure 22--Lock Assembly

7. Remove (2) screws from latch assembly at door frame. Remove this portion from the door.

8. Remove four (4) nuts and lock tumbler clip. Remove lock mechanism. See Figure 22.

### INSTALLATION - TYPE III

1. Check sealer around lock opening in door, replace or fill in as required to insure proper seal between lock assembly and door.

2. Apply a liberal amount of lubriplate to all contacting surfaces. Secure assembly with four (4) nuts.

3. Install lock tumbler and secure with clip.

4. Install latch assembly on door frame and loosely secure with two (2) screws on door frame.

5. Install lock button rod clip and actuator lever pin as shown in Figure 22.

6. Install inner panel and handle assembly. At the same time guide handle rod into lever at lock mechanism.

7. Install cotter pin to secure rod to lever.

8. Secure upper trim panel with screws.

9. Install lower door trim panel and window moulding.

## DOOR HINGES

### REMOVAL

1. Remove entrance door. Refer to "Door-Removal" earlier in this section.

2. Remove two (2) bolts per hinge.

3. Remove hinge.

### INSTALLATION

1. Install hinge on door frame and two (2) bolts. Torque to 25-30 ft. lbs.

2. Install entrance door. Refer to "Door-Installation" earlier in this section.

## ACCESS DOORS

### FRONT ACCESS DOOR LATCH REPLACEMENT

#### REMOVAL

1. Drill out rivets (2) on each side of handle. See Figure 23.

2. Remove "T" pin. See Figure 23.

3. Slide latch mechanism out of door.

#### INSTALLATION

1. Position latch mechanism in access door.

2. Install pop rivets.

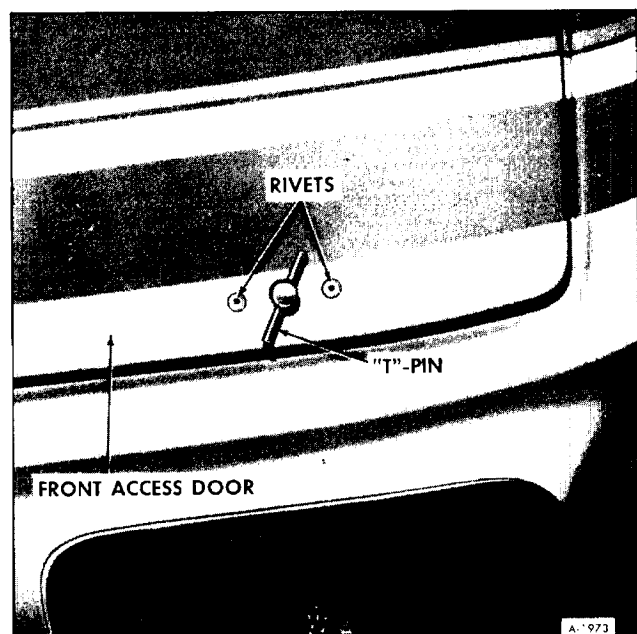

Figure 23-Front Access Door Latch

3. Install "T" pin.

### FRONT ACCESS DOOR REPLACEMENT

#### REMOVAL

1. On outboard side of door remove two nuts and bolts retaining support to door.

2. Remove nuts and bolts retaining hinge to body.

3. Remove access door.

#### INSTALLATION

1. Position access door in body opening and install hinge retaining nuts and bolts to body.

2. Position access door support to access door and secure with nut and bolt.

### EXTERNAL UTILITIES COMPARTMENT DOOR REPLACEMENT

#### REMOVAL

1. Drill out four pop-rivets holding piano hinge to body (See figure 24).

2. Remove door. Door may be removed from hinge by drilling out four pop-rivets retaining door to hinge.

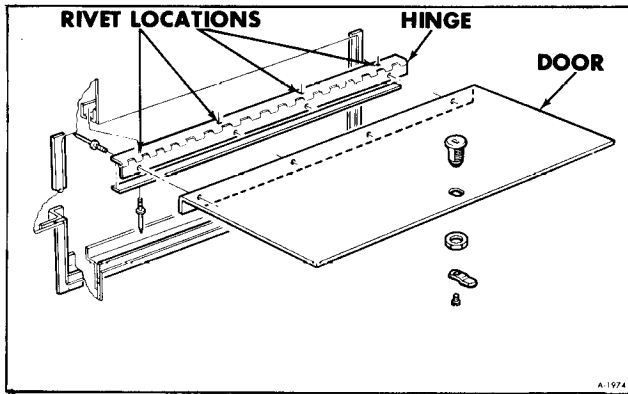

Figure 24-External Utilities Compartment Door

## INSTALLATION

Position door and hinge assembly in its opening and pop-rivet door in place.

## LP GAS, OR STORAGE DOOR REPLACEMENT

Both LP gas door and the storage (or motor generator) door are removed and installed in the same manner.

### REMOVAL

1. With the access door closed drill out pop rivets that retain the hinge to the body.
2. Unfasten latches and remove door.

### INSTALLATION

1. Position door in its opening.
2. Pop rivet hinge to body.

## LAP BELT MAINTENANCE

Keep belts clean and dry. Clean periodically with a mild soap solution and lukewarm water. Keep sharp edges and damaging objects away from belts. Periodically inspect belts, buckles, retractors, and anchors for damage that could materially lessen the effectiveness of the belt installation and repair or

replace the questionable parts. Do not bleach or dye belts as this may cause severe loss of strength.

If necessary, to replace belts or related attaching parts be sure to tighten lap belt anchor bolts to 35-45 foot-pounds torque.

## FLOOR

### GENERAL INFORMATION

The floor of the vehicle is made of 1 inch plywood sections. The plywood is treated with a wood preservative. The plywood sections are pop-riveted to the extruded aluminum supports as shown in Figure 25. The floor sections can be replaced but repair is more practical and is covered later in this section.

The engine cover, the only section designed to be removed, is located between the driver and passenger seat and is secured by a lip in the front and two screw attachments at each rear corner.

The wheel houses are made of plastic polyethylene. The front housings are repairable or replaceable if damaged. The rear housing are repairable if damaged. The entire underfloor area has been sprayed with a rust preventative and sealer coating.

### FRONT WHEEL HOUSINGS

#### REMOVAL

1. Remove six (6) screws securing housing to fiberglass wheel opening.
2. Remove one (1) bolt securing housing to floor support.
3. Remove wheel housing.

#### INSTALLATION

1. Install and position wheel housing.
2. Install one (1) bolt securing housing to floor support.

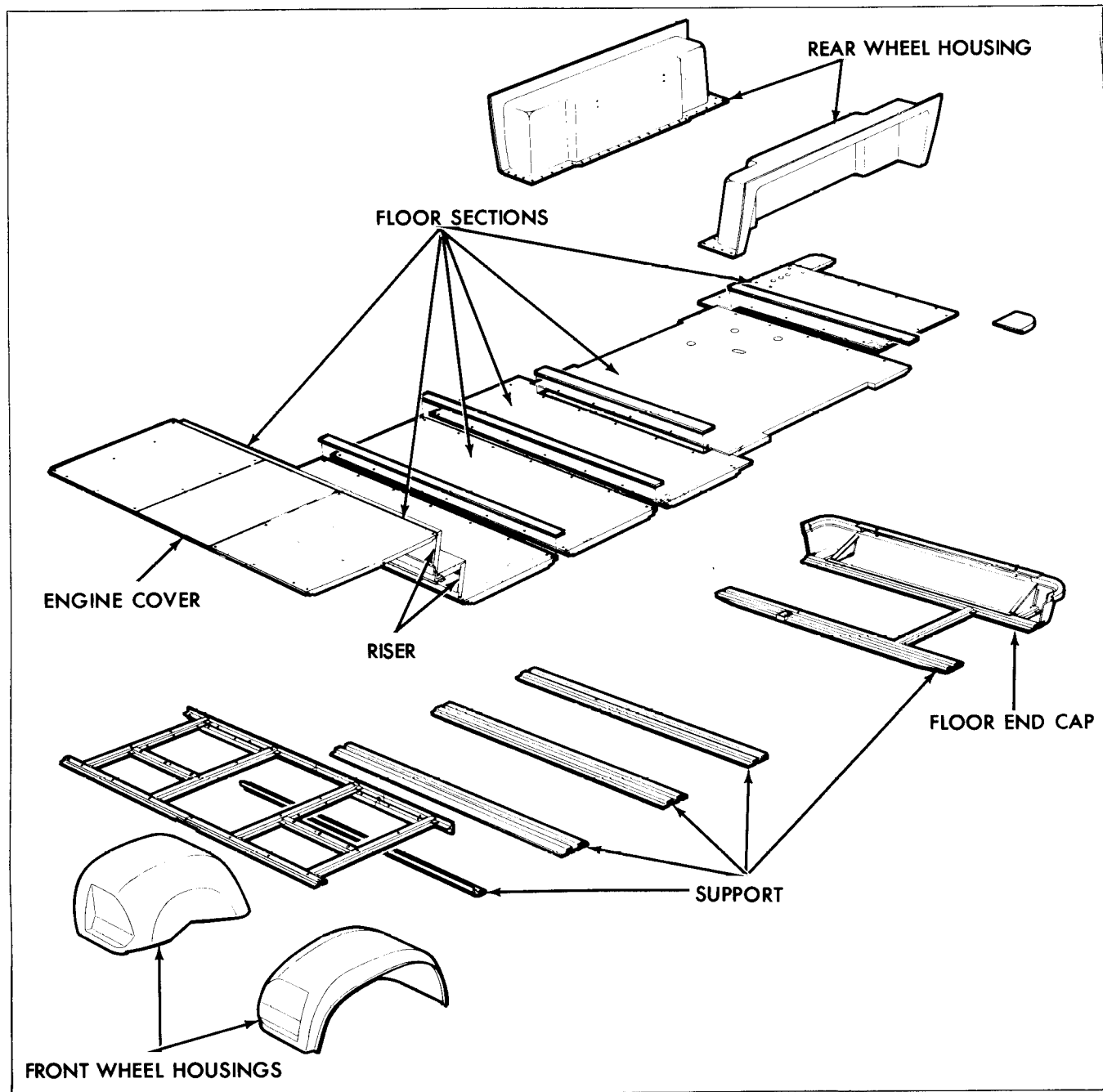

Figure 25—Wheel Housings and Floor (Model 260 Shown)

3. Install six (6) screws to secure housing to fiberglass wheel opening.

## PLYWOOD FLOOR

**CAUTION:** Before drilling, sawing, chiseling etc. the plywood be sure damage will not occur to components directly under the floor.

A thorough inspection of the damaged floor area should be made before attempting any repair. The damaged area should be replaced with one inch exterior grade plywood. One inch plywood will not only provide proper strength but it also, has an insulation rating equal to the insulation applied to the sides and roof of the vehicle. It is not necessary to replace an entire section but this will depend on the location and the extent of the damage.

All sections are secured to the supports with pop-rivets. Any pop-rivet may be removed by drilling

into the center of the rivet with a 3/16" drill bit. Drill approximately 1/8" deep and with a punch tap into this hole to drive the rivet shaft out.

**CAUTION:** *Care must be taken to properly seal any seams or joints resulting from floor section replacement or repair. Exhaust gases, dust, water etc. will leak past any seam or joint not caulked.*

The underside surfaces of new plywood must be coated with a wood preservative.

## ENGINE COVER

This removable floor section is made of one inch plywood. A seal is secured to the underside of the cover with an adhesive and staples. A damaged gasket should be replaced using a suitable adhesive and staples.

The rear corners of the cover are secured by screwing the bolt into a clip nut mounted to the cover frame. Proper operation of this fastener is important to allow the cover seal to make good contact with the frame.

Fasteners are replaceable and are held in place with two wood screws. Peel back the carpeting from the corner as required to gain access to wood screws. The clip nut is a standard hardware item and is replaceable.

If the fastener is replaced apply some adhesive to the cover to hold the carpet in place at the corners.

## REAR WHEEL HOUSINGS

All wheel houses as previously mentioned are constructed of plastic (polyethylene). Also, mentioned in "Front Wheel Housing-Removal" was the fact only the front wheel houses are replaceable besides being repairable. The rear wheel houses are repairable.

Any repair to the wheel houses will have to be with cover patches secured by fasteners. The chemical composition of polyethylene resists standard plastic adhesives. The suggested repair is to cut out a patch to cover the damaged area. Black polyethylene will make the best patch but sheet metal or sheet aluminum may be used. Hold the patch in place and mark the patch in places (1 1/2" to 2" apart) to be drilled. Remove the patch and select the proper drill bit. Drill holes in the patch. Place patch back on wheel house and mark wheel house in places to be drilled. Drill holes in wheel house being very careful not to drill any deeper than required to penetrate the 1/5" thick wheel house.

Apply a liberal amount of caulking on the patch. Position patch on wheel house and use pop-rivets to secure the patch to wheel house.

If sheet metal or sheet aluminum were used the patch area may be painted black.

## REPAIR OF FIBERGLASS COMPONENTS

Before starting repair operations, look for hidden damage by applying force around the damaged area, looking for hairline cracks and other breakage. Early repair of minor damage may prevent major repair later.

### PRECAUTIONS

Crems are available to protect the skin from a condition known as occupational, or contact dermatitis. Improved resin formulas have almost eliminated skin irritation. Cream is available for persons who may have a tendency toward skin irritation from the resins or dust.

The application of these creams is recommended whenever the resin materials are used. Generally the cream is not required when the plastic (epoxy) solder kit is being used.

1. Remove resin mixture from hands as soon as possible and always before mixture starts to gel. This can be observed by the action of the material being used. Resin may be removed with lacquer thinner by washing in soap and water.

2. Respirators are recommended when grinding. Also, some minor skin irritation from glass and powdered cured resin may be evident. Washing in cold water will help to minimize.

3. Use a sander with a vacuum attachment for dust control whenever possible.

4. Resin mixtures may produce toxic fumes and should be used in well ventilated areas.

5. Be careful not to get any resin material on clothing.



6. Use the proper materials for the job.

7. Keep materials, utensils and work area clean and dry. These repairs involve chemical reactions, and dirt or moisture may upset the chemical balances and produce unsatisfactory results.

## REPAIR PROCEDURES

For repair procedures refer to General Motors Service Information Bulletin (B-4). Copies of the

fiberglass repair bulletin (B-4) may be ordered from the following address:

General Motors Service Information

P.O. Box 7124

Detroit, Michigan, 48202

Materials, for repairing damaged fiberglass panels, are available in kit form through GM Dealerships, or equivalent kits can be purchased locally.

## SHEET METAL REPAIR

The aluminum panels on the body may be repaired if damaged. Filler putty can be used for minor dents, scratches, scraps etc. However, major damage to a panel will require removal of at least part of the panel. Because the panels are secured to the ribs with a polyurethane adhesive, separating and removing panels is difficult. Any rivets used on the panels are easily removed by drilling off the rivet head and, using a punch, drive out the rivet shaft.

All windows, access doors, vents, belt and roof line trim mouldings in the damaged area should be removed before removing the panel.

An air chisel will be helpful to remove the panel. Operate the air chisel along the rib to break the adhesive bond between the panel and the rib.

**CAUTION:** *Be careful during chiseling, sawing, drilling etc. on the aluminum panels not to damage wiring, piping, insulation, components etc. which are located immediately behind the panels.*

Any damaged rib will have to be straightened, replaced or have shim material fastened to the rib so

proper support will be provided for the aluminum panel.

A replacement panel should be fitted after the ribs have been thoroughly cleaned of adhesive. A suggested method would be to grind off the adhesive with an extra coarse disc on an air driven grinding wheel.

With the ribs cleaned a new panel may be fitted into the opening. Next, with the panel in place drill holes, or use existing holes, (at each corner and along the belt line and roof line) through the panel and rib for using pop-rivets.

Remove panel and apply adhesive such as manufactured by Minnesota Mining and Manufacturing XB3529 or equivalent to the rib. Follow the manufacturers mixing and curing instructions. Position panel in place and pop-rivet using pre-drilled holes.

The adhesive will cure at room temperature in 24 hours. The rivet holes may be ground off and the holes filled with a body putty.

## SEATS

### DRIVER AND SINGLE PASSENGER SEAT

The seat assembly can be removed by itself or as a unit with pedestal assembly.

#### SEAT REMOVAL

1. Swivel chair to a 45° position.

2. This will allow access to the four retaining bolts. Remove four bolts (See figure 26).

3. Remove seat.

#### SEAT INSTALLATION

1. Swivel top of pedestal to allow access to seat mounting holes.

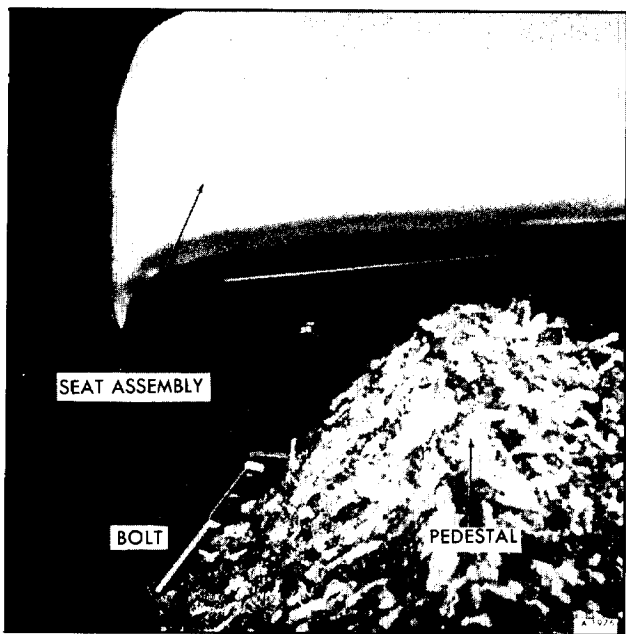

Figure 26—Seat Attaching Bolts

2. Position spacers and install retaining bolts to weld nuts in base of seat. Tighten securely.

## PEDESTAL REPLACEMENT

### REMOVAL

1. Remove seat as described above.

2. Remove nine nuts and bolts from base of pedestal. (Access to nuts can be made through the engine access cover)

3. Remove pedestal.

### INSTALLATION

1. Position pedestal over mounting holes.

2. Install nuts and bolts to retain pedestal.

3. Install seat as described previously in this section.

## DUAL PASSENGER SEAT REPLACEMENT

The dual passenger seat is removed in the same manner as the driver and single passenger seat, refer to the preceding procedures for removal and installation.

The pedestal for the dual passenger seat is also removed by the same method as the driver and single passenger seat pedestal.

## MIRRORS AND SUN VISOR

### INSIDE REAR VIEW MIRROR

#### REMOVAL

1. Loosen set screw at base of mirror.

2. Slide mirror to the rear and remove.

#### INSTALLATION

1. Position mirror on sun visor and mirror mounting bracket.

2. Tighten set screw.

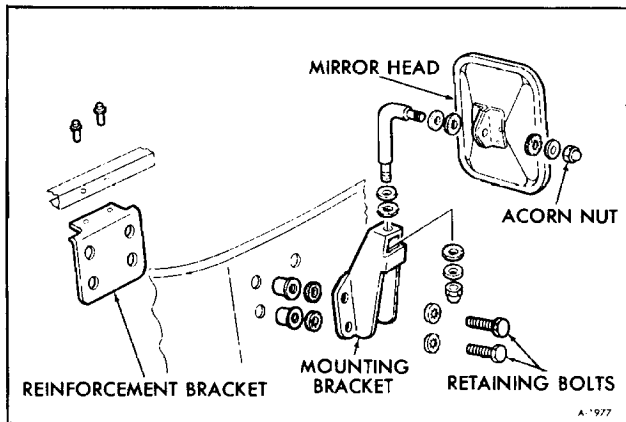

Figure 27—Exterior Mirror

### OUTSIDE REARVIEW MIRROR (FIGURE 27)

The entire mirror assembly can be removed by removing four retaining bolts from the mirror bracket. Install by replacing these four bolts.

Either the mirror head or support arm can be removed by removing the acorn nut as shown in Figure 27.

A reinforcement bracket is used to back the riv-nuts which retains the mirror assembly to the body. This bracket is held in place by two rivets to the sill.

## SUN VISOR

### REMOVAL

Remove visor from center support bracket, and

swing visor to side. Visor can now be removed by loosening hex head bolt at end of visor shaft.

### INSTALLATION

Position visor and install threaded end of visor arm into its mounting bracket. Tighten hex head bolt and position visor in support clip.

## RADIATOR GRILLE (FIGURE 28)

### REMOVAL

1. Open front access doors.
2. Remove six nuts from inside of grille.
3. Remove grille.

### INSTALLATION

1. Position grille with studs through body.
2. Install six nuts and washers to retain grille in proper position.

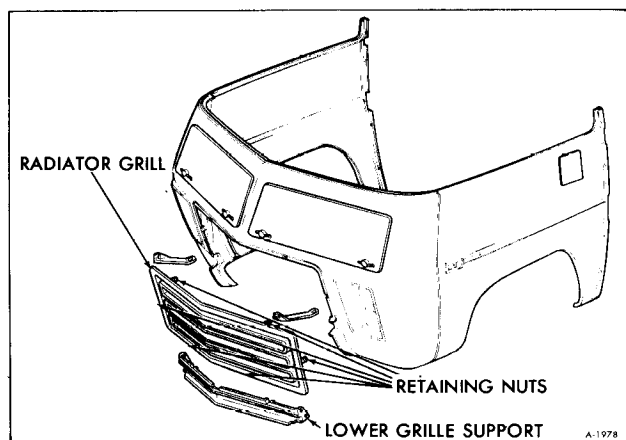

Figure 28-Radiator Grille

## END CAP

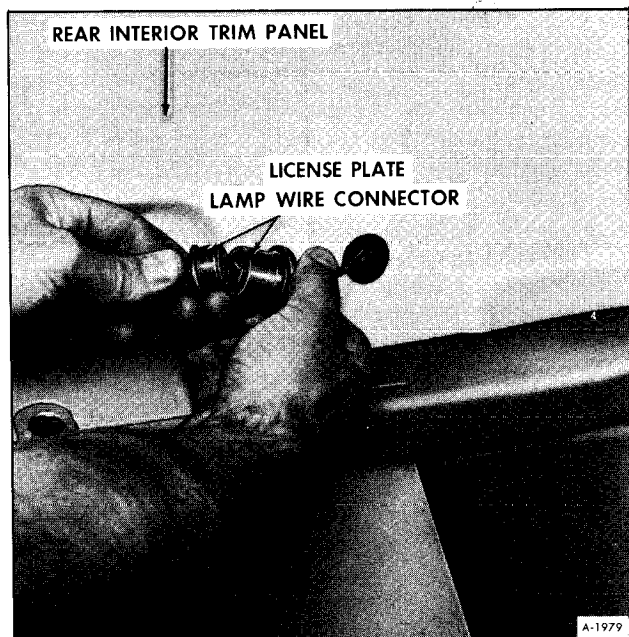

Figure 29-Disconnecting Wire to License Plate Lamp

### REMOVAL

1. Disconnect wires for license plate light at lower left-hand inside corner as shown in Figure 29.

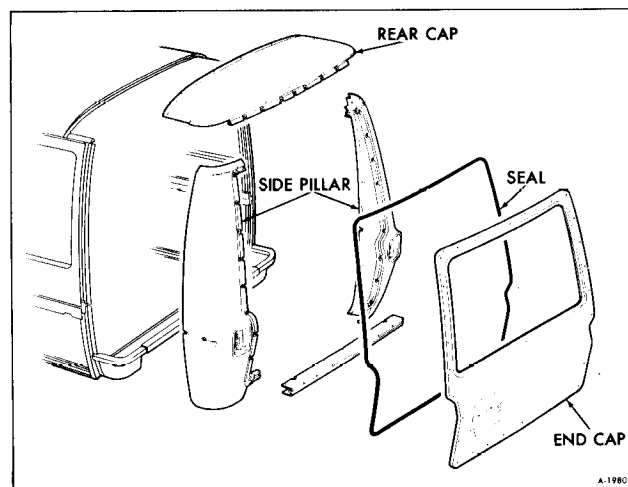

Figure 30-End Cap Components

**NOTE:** It may be necessary to remove interior trim at rear of Motor Home to gain access to license plate wiring connector.

2. Remove screws from interior trim to end cap.
3. Remove end cap to body retaining screws (32) from end cap (See figure 30).
4. Remove end cap from body.

## INSTALLATION

1. Check seal to make sure it is still intact. Replace seal, if necessary.
2. Position end cap in place and install 32 retaining screws.
3. Install screws retaining interior trim to end cap.
4. Reconnect license plate wiring.

## SPECIAL TOOLS

J-2189  
J-9316

Glass Seal and Insert Installer  
Windshield Alignment Blocks

# AIR CONDITIONING SYSTEM (INCLUDES HEATING)

Contents of this section are listed below:

SUBJECT	PAGE NO.
General Description.....	1-23
System Components and Their Function.....	1-31
General Information .....	1-44
Inspection and Periodic Service .....	1-49
Evacuating and Charging Procedures .....	1-49
Refrigerant Quick Check Procedure.....	1-54
Maintenance and Adjustments .....	1-54
General Repair Procedures and Component Replacement.....	1-56
Compressor Minor Overhaul Procedures.....	1-64
Compressor Major Overhaul Procedures .....	1-68
Leak Testing the Compressor .....	1-78
Air Conditioning Diagnosis .....	1-78
Vacuum Control Charts .....	1-85
Special Tools .....	1-85

## GENERAL DESCRIPTION

Both the heating and cooling functions are performed by this system. Air entering the vehicle must pass through the cooling unit (evaporator) and through (or around) the heating unit, in that order, and the system is thus referred to as a "reheat" system.

The evaporator provides maximum cooling of the air passing through the core when the air conditioning system is calling for cooling. A thermostatic switch, located in the blower-evaporator case, acts to control compressor operation by sensing the fin temperature of the evaporator core.

System operation is as follows: Air, either outside air or recirculated air, enters the system and is forced through the system by the blower. As the air passes through the evaporator core, it receives maximum cooling if the air conditioning controls are calling for cooling. After leaving the evaporator, the air enters the Heater and Air Conditioner Selector Duct Assembly where, by means of diverter doors, it is caused to pass through or to bypass the heater core in the proportions necessary to provide the desired outlet temperature. Conditioned air then enters the vehicle through the dash outlets. When, during cooling operations, the air is cooled by the evaporator to below comfort level, it is then warmed by the heater to the desired temperature. During "heating only" operations, the compressor will not be in operation and ambient air will be warmed to the desired level in the same manner.

The dash outlets are rectangular in design and have two-way action. The whole outlet can be swiveled and the inside louvers can be turned to direct air as desired. Also there are two floor outlets.

## THEORY OF OPERATION

### HEAT

We all know what air conditioning does for use but very few understand how or why it works. An air conditioner is functionally very similar to a refrigerator. A refrigerator is a simple mechanism which, surprisingly enough, works quite a bit like a teakettle boiling on a stove. That may sound far-fetched, but there is more similarity between the two than most of us would suspect. A modern refrigerator can make ice cubes and keep food cool and fresh only because a liquid called the refrigerant boils inside the freezer.

Everyone knows a boiling teakettle is "hot" and a refrigerator is "cold". We usually think of "cold" as a definite, positive condition. The only way we can define it is in a rather negative sort of way by saying "cold" is simply the lack of heat, just as darkness is the lack of light. We can't make things cold directly. All we can do is remove some of the heat they contain and they will become cold as a result. And that is the main job of any refrigerator. Both are simply devices for removing heat.

### Transfer of Heat

The only thing that will attract heat is a colder object. Like water, which always flows downhill, heat always flows down a temperature scale - from a warm level down to a colder one. When we hold our hands out toward the fireplace, heat flows from the hot fire out to our cold hands (figure 1). When

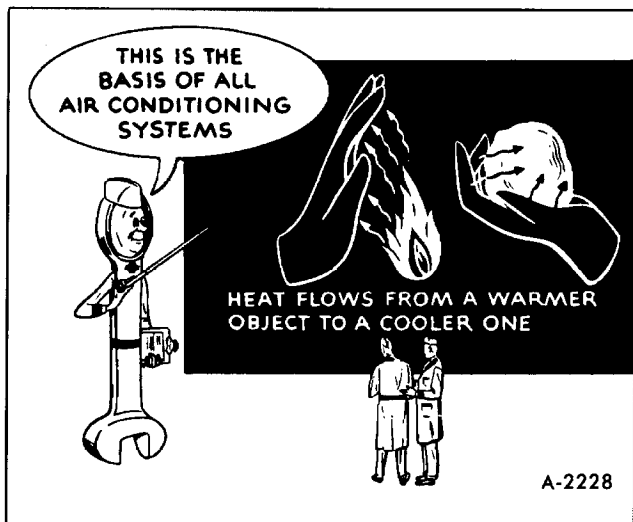

Figure 1-Heat Transfer

we make a snowball, heat always flows from our warm hands to the colder snow.

**Measurement of Heat**

Everyone thinks he knows how heat is measured. Thermometers are used in every home. (Whenever we speak of temperature from now on, we will mean Fahrenheit). They can tell how hot a substance is, but they can't tell us everything about heat.

When we put a teakettle on a stove, we expect it to get hotter and hotter until it finally boils. All during the process, we can tell exactly how hot the water is by means of a thermometer (figure 2). Our thermometer will show us that the flame is just as hot when we first put the teakettle on the stove as it is when the water finally boils. Why doesn't the water boil immediately? Why does it take longer to boil a

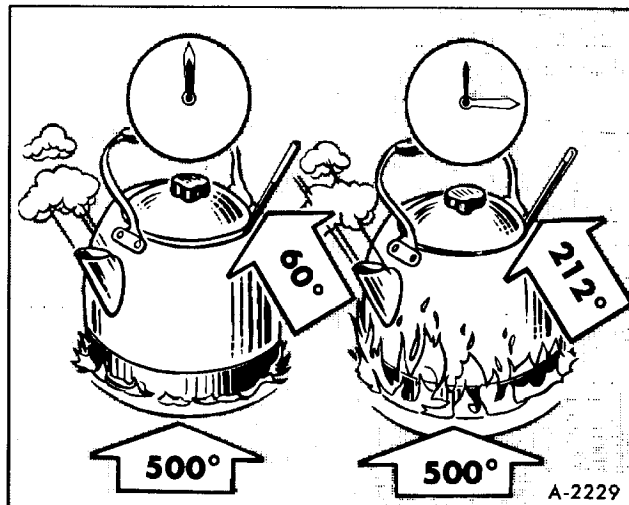

Figure 2-Measurement of Heat

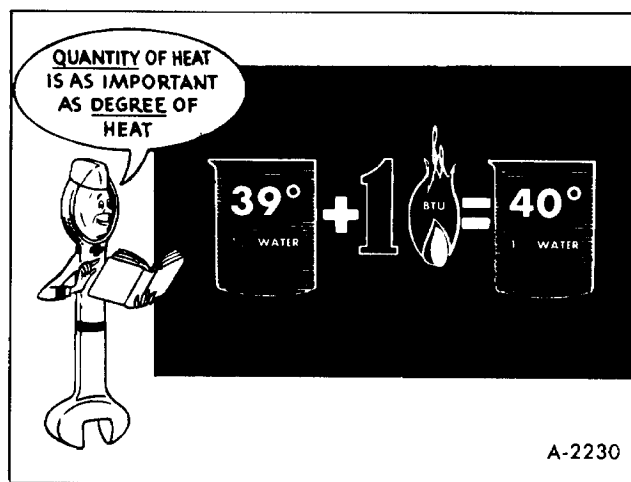

Figure 3-Quantity of Heat

quart of water than a cupful? Obviously temperature isn't the only measurement of heat.

Even though heat is intangible, it can be measured by quantity as well as intensity. Thermometers indicate only the intensity of heat. The unit for measuring quantity of heat is specified as that amount necessary to make 1 pound of water 1 degree warmer (figure 3). We call this quantity of heat a British Thermal Unit. Oftentimes, it is abbreviated to B.T.U.

Perhaps we can get a better idea of these two characteristics of heat if we think of heat if we think of heat as a sort of coloring dye. If we add one drop of red dye to a glass of water, it will turn slightly pink. Another drop will make the water more reddish in color. The more drops of dye we add, the redder the water will get. Each drop of dye corresponds to 1 B.T.U. and the succeeding deeper shades of red are like increases in temperature.

It may seem a little puzzling to talk about heat in a manual on air conditioning...but, when you stop to think about it, we are handling heat exclusively. Although we ordinarily think of an air conditioner as a device for making air cold, it does that indirectly. What it does is to take heat away from the air and transfer that heat outside the vehicle.

We know now that cold is nothing more than the absence of heat, and that heat always flows from a warm object to a colder one. We also have a clearer idea of how heat is measured.

From everything we've learned about heat so far, it seems to behave in a perfectly normal manner. Yet sometimes heat will disappear without leaving a single clue.

## Ice vs Water For Cooling

Every once in a while in the old days, the iceman would forget to stop by to refill the icebox. Occasionally, as the last sliver of ice melted away, somebody would come up with a bright idea. He would remember that the water in the drainpan always felt iccold when he emptied it other times. So, he would get the thermometer out and check its temperature. Sure enough, it usually was about as cold as the ice. Why not put the drainpan back in the ice compartment to keep things cold until the iceman returned the next day?

For some strange reason, the icebox never stayed cold. The drain water soon got quite warm and in a couple of hours, the butter in the icebox would begin to melt, the milk would start to sour, and the vegetables would wilt.

The drain water was only a few degrees warmer than the ice yet it didn't draw nearly as much heat out of the stored foods. The difference between the behavior of cold drain water and ice is the real secret as to how any refrigerator works, and we can easily see this by using an ordinary thermometer.

When we put a drainpan full of cold water into the ice compartment, we expect the heat to flow from the warm foods to the colder water. Remember, that heat always flows from a warm object to a colder object and when we add heat to water, it gets warmer. Each B.T.U. of heat added to a pound of water makes it one degree warmer.

If we were to put a thermometer in the cold drain water, we would see the temperature gradually creep upwards. That is to be expected because heat is flowing into the cold water making it warmer. Before long the water would be as warm as the stored foods. Then the water could no longer attract heat because heat will not flow from one warm object to another equally warm object. Since we no longer can draw heat out of the foods we no longer are cooling them.

Now, let's see what happens when we put ice instead of cold water into the icebox. This time, we'll set the thermometer on top of the ice (figure 4). When we first look at the thermometer, it reads 32°. A couple of hours later, the ice chunk is smaller because some of the ice has already melted away – but the thermometer still reads 32°.

All this time, the ice has been soaking up heat, yet it never gets any warmer no matter how much heat it draws from the stored food. On the other hand, the cold drain water got progressively warmer as it soaked up heat. The addition of heat will make water warmer yet won't raise the temperature of ice above the 32° mark.

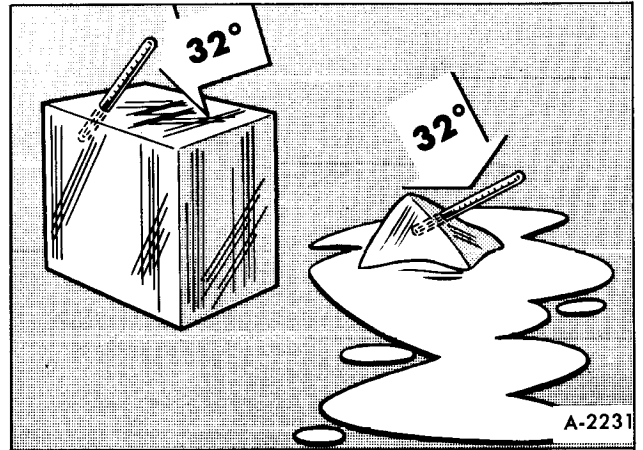

Figure 4—Melting Ice Remains at 32°

If we fill one drinking glass with ice and another with cold water, and put both glasses in the same room where they could absorb equal amounts of heat from the room air, we will find it takes much, much longer for the ice to melt and reach room temperature than it did for the water in the other glass to reach the same temperature. Obviously, most of the heat was being used to melt the ice. But it was the heat that apparently disappeared or was transformed because it couldn't be located with a thermometer. To describe this disappearing heat scientists chose the word "latent" which means hidden.

## Latent Heat

So latent heat is nothing more or less than hidden heat which can't be found with a thermometer.

At first it was thought that latent heat was in the water that melted from the ice. But that wasn't exactly the right answer because, upon checking water temperature as it melts from ice, it will be found that it is only a shade warmer than the ice itself. It is not nearly warm enough to account for all the heat the ice had absorbed. The only possible answer is that the latent heat had been used up to change the ice from a solid into a liquid.

Many substances can be either a solid, or a liquid, or a gas. It just depends on the temperature whether water for example was a liquid, or a solid (ice), or gas (steam) (figure 5).

All solids soak up huge amounts of heat without getting any warmer when they change into liquids, and the same thing will happen when a substance changes from a liquid into a gas.

Put some water in a teakettle, set it over a fire and watch the thermometer as the water gets hotter and hotter, the mercury will keep rising until the water

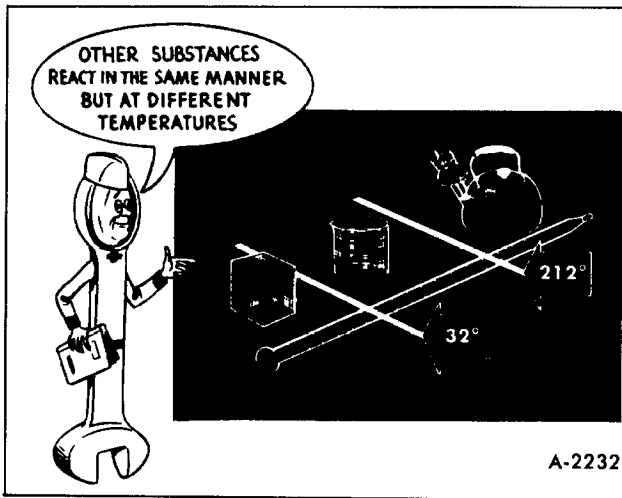

Figure 5—Temperature Determines the State of Water

starts to boil. Then the mercury seems to stick at the 212° mark. Put more wood on the fire, despite all the increased heat, the mercury will not budge above the 212° mark (figure 6).

No matter how large or hot you make the flame, you can't make water any hotter than 212° at sea level. As a liquid changes into a gas, it absorbs abnormally great amounts of heat without getting any hotter.

Now we have two different kinds of latent heat, which are quite a bit alike. To keep their identities separate, the first one is called **latent heat of fusion**, which means the same as melting. The other kind is called **latent heat of vaporization** because that means the same as evaporation.

### Refrigeration

It may seem as though we have discussed heat instead of refrigeration. But in doing so, we have

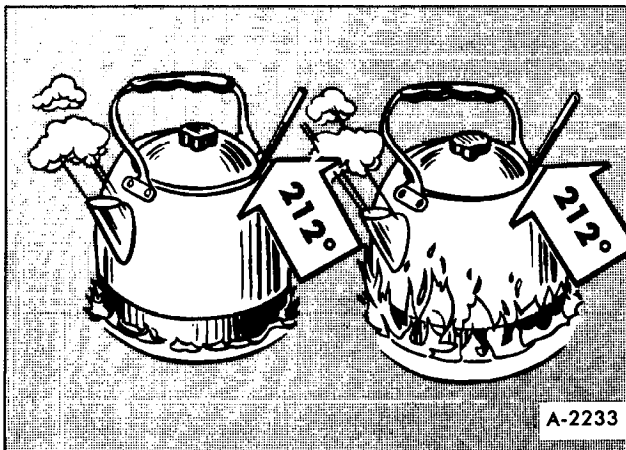

Figure 6—Boiling Water Never Exceeds 212° at Sea Level

learned how a simple icebox works. It's because the latent heat of fusion gives ice the ability to soak up quantities of heat without getting any warmer. Since it stays cold, it can continue to draw heat away from stored foods and make them cooler.

The latent heat of vaporization can be even better because it will soak up even more heat.

Whenever we think of anything boiling, we think of it being pretty hot, but that's not true in every case. Just because water boils at 212° doesn't mean that all other substances will boil at the same temperature. Some would have to be put into a blast furnace to make them bubble and give off vapor. On the other hand, others will boil violently while sitting on a cake of ice.

And so each substance has its own particular boiling point temperature. But regardless of whether it is high or low, they all absorb unusually large quantities of heat without getting any warmer when change from a liquid into a vapor.

Consequently, any liquid that will boil at a temperature below the freezing point of water, will make ice cubes and keep vegetables cool in a mechanical refrigerator.

## REFRIGERANTS

The substance that carries heat out of a refrigerator cabinet is the refrigerant.

There are many refrigerants known to man. In fact, any liquid that can boil at temperatures somewhere near the freezing point of water can be used.

But a boiling point below the temperature at which ice forms is not the only thing that makes a good refrigerant. A refrigerant should also be non-poisonous and non-explosive to be safe. Besides that, we want a refrigerant that is non-corrosive and one that will mix with oil.

Chemists tried to improve existing natural refrigerants. But after exploring along that line, they still hadn't succeeded. They started from scratch and juggled molecules around to make an entirely new refrigerant. Eventually they succeeded by remodeling the molecules in carbon tetrachloride. This is the same fluid that was used in fire extinguishers and dry-cleaners' solvents.

From this fluid, the chemists removed two chlorine atoms and replaced them with two fluorine atoms. This newly formed fluid carried the technical chemical name of dichlorodifluoromethane. Today,



it is sold commercially by manufacturers as Refrigerant-12 or R-12. Non-tox, non-inflammable, non-explosive, and non-poisonous, however, breathing large quantities of R-12 should be avoided.

**Refrigerant-12**

Refrigerant-12, which we use in Air Conditioning Systems, boils at 21.7° below zero. Picture a flask of R-12 sitting on the North Pole boiling away just like a teakettle on a stove. No one would dare pick up the flask with his bare hands because, even though boiling, it would be so cold and it would be drawing heat away from nearby objects so fast that human flesh would freeze in a very short time.

If we were to put a flask of R-12 inside a refrigerator cabinet, it would boil and draw heat away from everything surrounding it (figure 7). So long as any refrigerant remained in the flask, it would keep on soaking up heat until the temperature got clear down to 21.7° below zero.

Now we can begin to see the similarity between a boiling teakettle and a refrigerator. Ordinarily we think of the flame pushing heat into the teakettle. Yet, it is just as logical to turn our thinking around and picture the teakettle pulling heat out of the flame. Both the teakettle and the flask of refrigerant do the same thing – they both draw in heat to boil although they do so at different temperature levels.

There also is another similarity between the icebox and the mechanical refrigerator. In the icebox, water from melting ice literally carried heat out of the cabinet. In our simple refrigerator, rising vapors do the same job.

**Reusing R-12**

R-12, or any other refrigerant, is too expensive

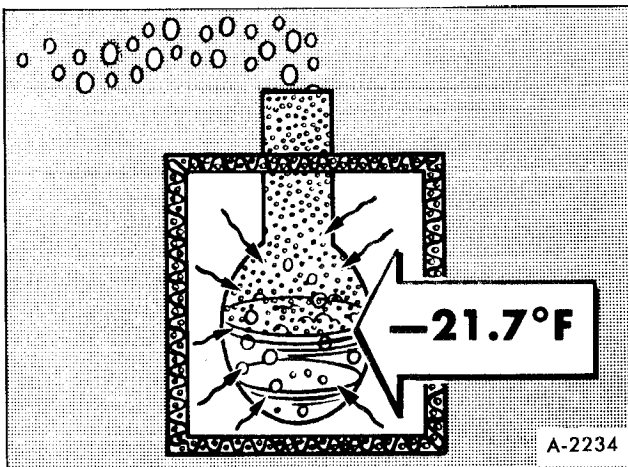

Figure 7-A Simple R-12 Refrigerator

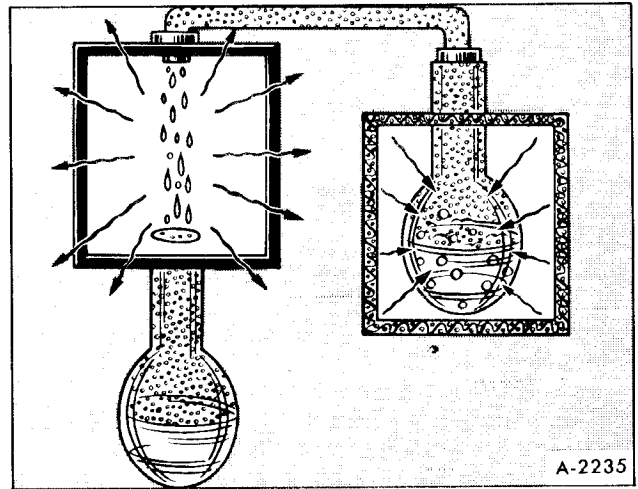

Figure 8- Reusing Refrigerant

just to let float away into the Atmosphere. If there was some way to remove the heat from the vapor and change it back into a liquid, it could be returned to the flask and used over again (figure 8).

That is where we find the biggest difference between the old icebox and the modern refrigerator. We used to put in new ice to replace that lost by melting. Now we use the same refrigerant over and over again.

We can change a vapor back into a liquid by chilling it, or do the same thing with pressure. When we condense a vapor we will find that the heat removed just exactly equals the amount of heat that was necessary to make the substance vaporize in the first place.

This is called the latent heat of vaporization - the heat that apparently disappeared when a liquid boiled into a vapor – again reappears - when that same vapor reverts back into a liquid. It is just like putting air into a balloon to expand it and then letting the same amount of air out again to return the balloon to its original condition.

We know that any substance will condense at the same temperature at which it boiled. This temperature point is a clear-cut division like a fence. On one side, a substance is a liquid. Immediately on the other side it is a vapor. Whichever way a substance would go, from hot to cold or cold to hot, it will change its character the moment it crosses over the fence.

Water will boil at 212° under normal conditions. Naturally, we expect steam to condense at the same temperature. But whenever we put pressure on steam, it doesn't. It will condense at some temperature higher than 212°. The greater the pressure, the higher the boiling point and the temperature at

which a vapor will condense. This is the reason why pressure cookers cook food faster, since the pressure on the water permits it to boil out at a higher temperature.

We know that R-12 boils at 21.7° below zero. A thermometer will show us that the rising vapors, even though they have soaked up lots of heat, are only slightly warmer. But the vapors must be made warmer than the room air if we expect heat to flow out of them. The condensing point temperature must be above that of room air or else the vapors won't condense.

This is where pressure helps, with pressure, we can compress the vapor, thereby concentrating the heat it contains. When we concentrate heat in a vapor that way, we increase the intensity of the heat or, we increase the temperature, because temperature is merely a measurement of heat intensity (figure 9).

**Pressure in Refrigeration**

Because we must use pressures and gauges in air conditioning service, the following points are mentioned so that we will all be talking about the same thing when we speak of pressures.

All pressure, regardless of how it is produced, is measured in pounds per square inch (psi).

Atmospheric Pressure is pressure exerted in every direction by the weight of the atmosphere. At sea level atmospheric pressure is 14.7 psi. At higher altitudes air has less weight (lower psi).

Any pressure less than atmospheric (14.7) is known as a partial vacuum or commonly called a vacuum. A perfect vacuum or region of no pressure has never been mechanically produced.

Gauge pressure is used in refrigeration work. Gauges are calibrated in pounds (psi) of pressure and inches of Mercury for vacuum. At sea level, "0" lbs. gauge pressure is equivalent to 14.7 lbs. atmospheric pressure. Pressure greater than atmospheric is measured in pounds (psi) and pressure below atmospheric is measured in inches of vacuum. The "0" on the gauge will always correspond to the surrounding atmospheric pressure, regardless of the elevation where the gauge is being used.

**Pressure-Temperature Relationships of R-12**

A definite pressure and temperature relationship exists in the case of liquid refrigerants and their saturated vapors. Increasing the temperature of a substance causes it to expand. When the substance is confined in a closed container, the increase in temperature will be accompanied by an increase in pressure, even though no mechanical device was used. For every temperature, there will be a corresponding pressure within the container of refrigerant. A table of the temperature-pressure relationship of R-12 is presented below. Pressures are indicated in gauge pressure, either positive pressure (above atmospheric) in pounds or negative pressure (below atmospheric) in inches of vacuum.

Thus if a gauge is attached to a container of R-12 and the room temperature is 70°, the gauge will register approximately 70 psi pressure; in a 100° room, the pressure would be 117 psi.

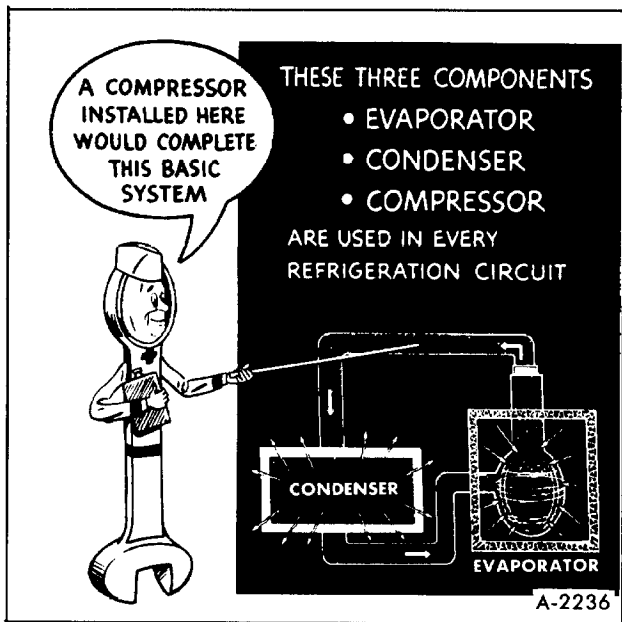

Figure 9—Basic Refrigerant Circuit

°F	Pressure (psi)	°F	Pressure (psi)
-40	11.0*	+50	46.7
-35	8.3*	+55	52.0
-30	5.5*	+60	57.7
-25	2.3*	+65	63.7
-20	0.6	+70	70.1
-15	2.4	+75	76.9
-10	4.5	+80	84.1
-5	6.8	+85	91.7
0	9.2	+90	99.6
+5	11.8	+95	108.1
+10	14.7	+100	116.9
+15	17.7	+105	126.2
+20	21.1	+110	136.0
+25	24.6	+115	146.5
+30	28.5	+120	157.1
+32	30.1	+125	167.5
+35	32.6	+130	179.0
+40	37.0	+140	204.5
+45	41.7	+150	232.0

\* Inches of Vacuum

## Pressure and Flow

When we use a tire pump to inflate an automobile tire, we are creating pressure only because we are “pushing” against the air already entrapped inside the tire. If a tire has a puncture in it, you could pump all day, and still not be able to build up any pressure. As fast as you would pump the air in, it would leak out through the puncture. Unless you have something to push against – to block the flow of air – you can’t create more than a mere semblance of pressure.

The same situation holds true in an air conditioning system. The compressor can pump refrigerant vapor through the system, but unless it has something to push against, it cannot build up pressure. All the compressor would be doing would be to circulate the vapor without increasing its pressure.

We can’t just block the flow through the system entirely. All we want to do is put pressure on the refrigerant vapor so it will condense at normal temperatures. This must be done sometime after the vapor leaves the evaporator and before it returns again as a liquid. High pressure in the evaporator would slow down the boiling of the refrigerant and penalize the refrigerating effect.

## Controlling Pressure and Flow

Pressure and flow can be controlled with a float valve, or with a pressure-regulating valve.

The float valve type will give us a better idea of pressure and flow control, let’s look at it first.

It consists simply of a float that rides on the surface of the liquid refrigerant. As the refrigerant liquid boils and passes off as a vapor, naturally the liquid level drops lower and lower. Correspondingly, the float, because it rides on the surface of the refrigerant, also drops lower and lower as the liquid goes down.

By means of a simple system of mechanical linkage, the downward movement of the float opens a valve to let refrigerant in. The incoming liquid raises the fluid level and, of course, the float rides up along with it. When the surface level of the refrigerant liquid reaches a desired height, the float will have risen far enough to close the valve and stop the flow of refrigerant liquid.

We have described the float and valve action as being in a sort of definite wide open or tight shut condition. Actually, the liquid level falls rather slowly as the refrigerant boils away. The float goes down gradually and gradually opens the valve just a crack. At such a slow rate of flow, it raises the liquid level in the evaporator very slowly.

It is easy to see how it would be possible for a stabilized condition to exist. By that, we mean a condition wherein the valve would be opened enough to allow just exactly the right amount of refrigerant liquid to enter the system to take the place of that leaving as a vapor.

## Refrigerator Operation

We’ve now covered all the scientific ground-rules that apply to refrigeration. Try to remember these main points. All liquids soak up lots of heat without getting any warmer when they boil into a vapor, and, we can use pressure to make the vapor condense back into a liquid so it can be used over again. With just that amount of scientific knowledge, here is how we can build a refrigerator.

We can place a flask of refrigerant in an icebox. We know it will boil at a very cold temperature and will draw heat away from everything inside the cabinet (figure 9).

We can pipe the rising vapors outside the cabinet and thus provide a way for carrying the heat out. Once we get the heat-laden vapor outside, we can compress it with a pump. With enough pressure, we can squeeze the heat out of “cold” vapor even in a warm room. An ordinary radiator will help us get rid of heat.

By removing the heat, and making the refrigerant into a liquid, it becomes the same as it was before. So, we can run another pipe back into the cabinet and return the refrigerant to the flask to be used over again.

That is the way most mechanical refrigerators work today. Now, let’s look at air conditioning to see the benefits of air conditioning and how an air conditioner works.

## AIR CONDITIONING

Because air-conditioning has always been very closely allied with mechanical refrigeration, most of us are apt to think of it only as a process for cooling room air.

Air Conditioning goes beyond the mere cooling of the air. It controls the humidity, cleanliness and circulation of the air.

Whenever it gets warm and muggy in the summertime, someone is almost sure to say, “It’s not the heat...it’s the humidity.” But that is only partly right. Actually it is a combination of the two that makes us

feel so warm...temperature alone is not the only thing that makes us uncomfortable.

Humidity is the moisture content of the air. To a certain extent, it is tied in with the temperature of the air. Warm air will hold more moisture than will cold air. When air contains all the moisture it can hold, it is saturated, and the relative humidity is 100%. If the air contains only half as much water as it could hold at any given temperature, we say that the relative humidity is 50%. If it contains only a fifth of its maximum capacity, we say that the relative humidity is 20%. This amount of water vapor, or relative humidity, affects the way we perspire on hot days.

Nature has equipped our bodies with a network of sweat glands that carry perspiration to the skin surfaces. Normally, this perspiration evaporates and absorbs heat just like a refrigerant absorbs heat when it is vaporized in a freezer. Most of the heat is drawn from our bodies, giving us a sensation of coolness. A drop of alcohol on the back of your hand will demonstrate this principle convincingly. Alcohol is highly volatile, and will evaporate very rapidly and absorb quite a bit of heat in doing so, making the spot on your hand feel cool.

The ease and rapidity with which evaporation takes place, whether it be alcohol or perspiration, governs our sensation of coolness and to a certain extent, independently of the temperature. The ease and rapidity of the evaporation are directly affected by the relative humidity or comparative dampness of the air. When the air is dry, perspiration will evaporate quite readily. But when the air contains a lot of moisture, perspiration will evaporate more slowly; consequently less heat is carried away from our body.

From the standpoint of comfort, air-conditioning should control the relative humidity of the air as well as its temperature.

By reducing the humidity, we oftentimes can be just as "cool" in a higher room temperature than otherwise would be comfortable. Laboratory tests have shown that the average person will feel just as cool in a temperature of 79° when the relative humidity is down around 30% as he will in a cooler temperature of 72° with a high relative humidity of 90%.

There are practical limits though within which we must stay when it comes to juggling humidity. For comfort, we can't go much below a relative humidity of 30% because anything lower than that would cause an unpleasant and unhealthy dryness in the throat and nasal passages.

Summertime temperatures of 85° sometimes bring with them relative humidities around 75% to

80%. To gain maximum human comfort, an air conditioning system should cool the air down and reduce the humidity to comfortable limits.

Along with the cooling job it does, the evaporator unit also removes much of the moisture from the air. Everyone is familiar with the sight of thick frost on the freezer of a refrigerator. That frost is simply frozen moisture that has come out of the air.

The evaporator unit as an air conditioning system does the same thing with this one exception. Because its temperature is above the freezing point, the moisture remains fluid and drips off the chilling unit. A further advantage of air conditioning is that dust and pollen particles are trapped by the wet surfaces of the evaporator core and then drained off along with the condensed moisture. This provides very clean, pure air for breathing.

### BASIC AIR CONDITIONER

When we look at an air conditioning unit, we will always find a set of coils or a finned radiator core through which the air to be cooled passes. This is known as the "evaporator". It does the same job as the flask of refrigerant we spoke about previously. The refrigerant boils in the evaporator. In boiling, of course, the refrigerant absorbs heat and changes into a vapor. By piping this vapor outside the vehicle we can bodily carry out the heat that caused its creation.

Once we get vapor out of the evaporator, all we have to do is remove the heat it contains. Since heat is the only thing that expanded the refrigerant from a liquid to a vapor in the first place, removal of that same heat will let the vapor condense into a liquid again. Then we can return the liquid refrigerant to the evaporator to be used over again.

Actually, the vapor coming out of the evaporator is very cold. We know the liquid refrigerant boils at temperatures considerably below freezing and that the vapors arising from it are only a shade warmer even though they do contain quantities of heat. Consequently, we can't expect to remove heat from sub-freezing vapors by "cooling" them in air temperatures that usually range between 60° and 100°...heat refuses to flow from a cold object toward a warmer object.

But with a pump, we can squeeze the heat-laden vapor into a smaller space. And, when we compress the vapor, we also concentrate the heat it contains. In this way, we can make the vapor hotter without adding any heat. Then we can cool it in comparatively warm air.

That is the only responsibility of a compressor in an air conditioning system. It is not intended to be a pump just for circulating the refrigerant. Rather, its job is to exert pressure for two reasons. Pressure makes the vapor hot enough to cool off in warm air. At the same time, the compressor raises the refrigerant's pressure above the condensing point at the temperature of the surrounding air so it will condense.

As the refrigerant leaves the compressor, it is still a vapor although it is now quite hot and ready to give up the heat that it absorbed in the evaporator. One of the easiest ways to help refrigerant vapor discharge its heat is to send it through a radiator-like component known as a condenser.

The condenser really is a very simple device having no moving parts. It does exactly the same job as the familiar radiator in a typical home steam-heating

system. There, the steam is nothing more than water vapor. In passing through the radiator, the steam gives up its heat and condenses back into water.

The purpose of the condenser, as the name implies, is to condense the high pressure, high temperature refrigerant vapor discharged by the compressor into a high pressure liquid refrigerant. This occurs when the high pressure, high temperature refrigerant is subjected to the considerably cooler metal surfaces of the condenser. This is due to the fundamental laws, covered earlier, which state that "heat travels from the warmer to the cooler surface," and that "when heat is removed from vapor, liquid is produced."

When the refrigerant condenses into a liquid, it again is ready for boiling in the evaporator. So, we run a pipe from the condenser back to the evaporator.

## SYSTEM COMPONENTS AND THEIR FUNCTIONS

The air conditioning system used on the GMC Motor Home utilizes components in the following categories:

1. The Refrigeration Components
2. The Electrical Components
3. The Vacuum Components

It is important that the operation of these components be fully understood in order to properly diagnose and repair air conditioning problems.

### REFRIGERATION COMPONENTS

The refrigeration components are those which come in contact with and effect or are effected by the Refrigerant-12. They move it, cool it, warm it and regulate it.

### COMPRESSOR

The prime purpose of the compressor (figure 10) is to take the low pressure refrigerant vapor produced by the evaporator and compress it into a high pressure, high temperature vapor which will be sent on to the condenser.

It utilizes the principle that "when a vapor is compressed, both its pressure and temperature are raised" which we have already discussed. The com-

pressor is mounted above the engine in a special mounted bracket and is belt driven from the engine through an electro-magnetic clutch pulley on the compressor.

The compressor has three double-acting pistons, making it a six cylinder compressor. The compressor has a 1.5 inch bore and 1.1875 inch stroke, giving it a total displacement of 12.6 cu. in. Identification of the compressor is by model and serial number stamped on a plate on top of the compressor.

#### Clutch-Pulley

The movable part of the clutch drive plate is in front of the pulley and bearing assembly. The armature plate, the movable member, is attached to the drive hub through driver springs and is riveted to both members. The hub of the drive plate is pressed over a square drive key located in the compressor shaft. A spacer and retainer ring are assembled to the shaft and the assembly is held in place with a self-locking nut. The pulley rim, power element ring and pulley hub are formed into a final assembly by molding a frictional material between the rim and the hub with the power element ring imbedded in the forward face of the assembly.

A two-row ball bearing is pressed into the pulley hub and held in place by a retainer ring. The entire pulley and bearing assembly is then pressed over the front head of the compressor and secured by a retainer ring.

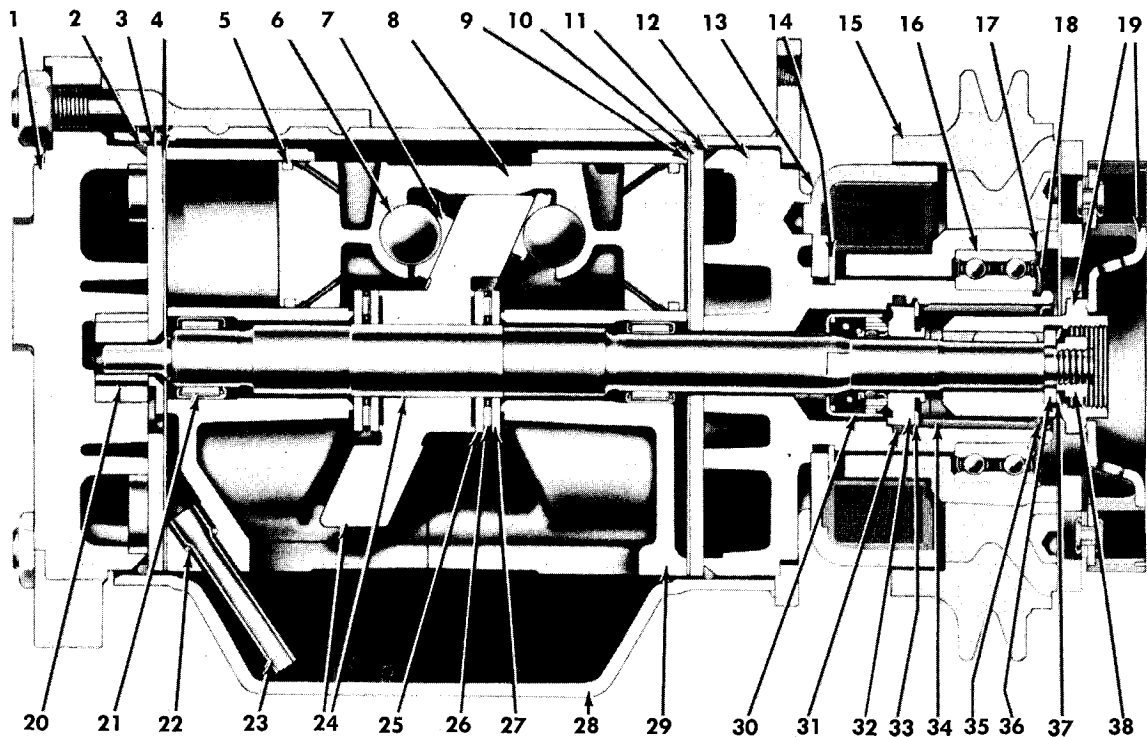

- |  |  |
|--|--|
| 1 Rear Head                            | 20 Oil Pump Gears                      |
| 2 Rear Head to Shell O-ring            | 21 Mainshaft Bearing (Rear)            |
| 3 Rear Discharge Valve Plate           | 22 Oil Inlet Tube O-ring               |
| 4 Rear Suction Reed Plate              | 23 Oil Inlet Tube                      |
| 5 Piston Ring                          | 24 Wobble Plate and Mainshaft Assembly |
| 6 Piston Drive Ball                    | 25 Thrust Race                         |
| 7 Ball Seat                            | 26 Thrust Bearing                      |
| 8 Piston                               | 27 Thrust Race                         |
| 9 Front Suction Reed Plate             | 28 Compressor Shell                    |
| 10 Front Discharge Valve Plate         | 29 Cylinder Assembly                   |
| 11 Front Head to Shell O-ring          | 30 Shaft Seal                          |
| 12 Front Head                          | 31 Shaft Seal Seat O-ring              |
| 13 Coil and Housing Assembly           | 32 Shaft Seal Seat                     |
| 14 Coil Housing Retainer Ring          | 33 Shaft Seal Seat Retainer Ring       |
| 15 Pulley and Bearing Assembly         | 34 Felt Sleeve                         |
| 16 Pulley Bearing                      | 35 Felt Sleeve Retainer                |
| 17 Pulley Bearing Retainer Ring        | 36 Spacer                              |
| 18 Pulley and Bearing Retainer Ring    | 37 Clutch Hub Retainer Ring            |
| 19 Clutch Hub and Drive Plate Assembly | 38 Shaft Nut                           |

T-4175

Figure 10-Compressor Cross Sectional View

### Clutch Coil

The coil is molded into the coil housing with a filled epoxy resin and must be replaced as a complete assembly. Three protrusions on the rear of the housing fit into alignment holes in the compressor front head. A retainer ring secures the coil and housing in place. The coil has 3.85 ohms resistance at 80°F. ambient temperature and will require no more than

3.2 amperes at 12 volts D.C. Since the clutch coil is not grounded internally, a ground lead is required as well as a "hot" lead. This will be discussed in greater detail in the Electrical Component discussion in this section.

### Shaft Seal

The main shaft seal, located in the neck of the

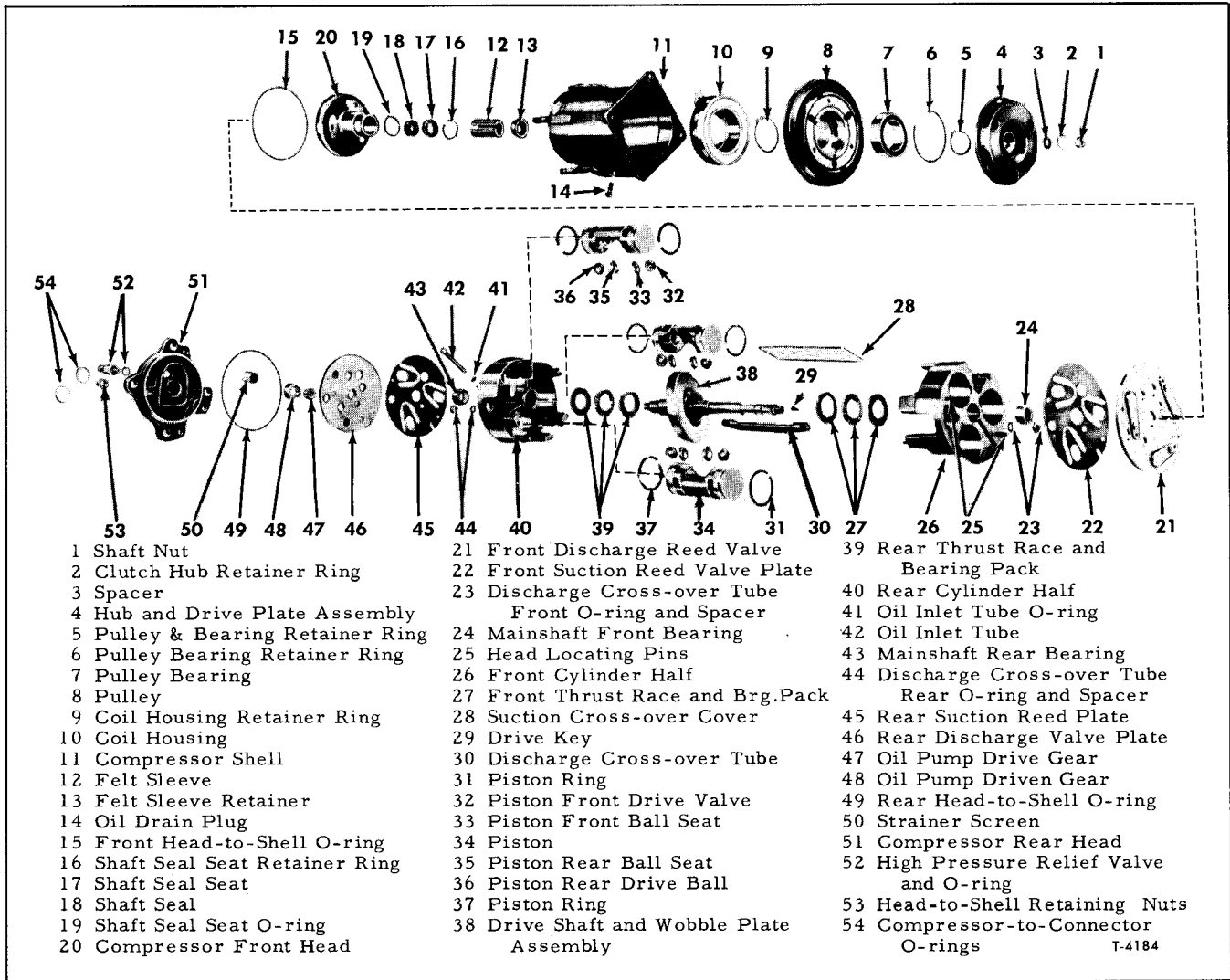

Figure 11-Compressor Exploded View

compressor front head, consists of the seal assembly with its ceramic seal face in a spring loaded cage. An "O" ring seal, located within the ceramic seal, provides a seal to the shaft surface. The contact surface of the shaft seal seat is finished to a high polish and must be protected against nicks, scratches and even fingerprints. Any surface damage will cause a poor seal. An "O" ring, located in an internal groove in the neck of the front head provides a seal with the outer diameter of the seal seat. A retainer ring, tapered side away from the seat, secures the seat in place. The hub and armature plate must be removed to gain access to the seal. A shaft seal kit contains all necessary replacement parts for field service.

After removing the clutch drive, pulley-bearing and coil housing assemblies, the rear head and internal mechanism (figure 10) may be removed from the compressor shell. Four threaded studs, welded to the compressor shell, locate the rear head and four lock nuts secure it in place.

### Rear Head

The rear head (figure 11) has a machined cavity in the center for the oil pump gears. This cavity, in all compressors, is machined so that the eccentricity of the bore is approximately .042 inch to the LEFT of the centerline of the cavity. The counterclockwise rotation compressor used in some other systems has the eccentricity machined approximately .042 inch to the RIGHT of the cavity centerline. A small diameter hole is drilled in the head between the two. The unit number is stamped on a plate attached to the counterclockwise rotation head and a decal arrow indicates the direction of rotation.

### Mainshaft

The central mainshaft, driven by the clutch-pulley when the coil is energized, extends through the front head to the rear head and oil pump cavity of

the compressor. The shaft revolves in needle roller bearings located in the front and rear halves of the cylinder assembly. 3/16" internally drilled passage extends through the shaft from the rear oil pump cavity to the shaft seal cavity in the front compressor head. Four .078 inch holes, drilled at 90° to the main passage, direct oil under pump pressure to the shaft seal surfaces, thrust bearings and shaft-cylinder bearings.

### Wobble Plate

The wobble plate is an angular shaped member pressed onto the mainshaft forming the mainshaft and wobble plate assembly (figure 11). A woodruff key prevents movement of the plate around the shaft. Location of the plate on the shaft is factory set and must not be changed. The very smooth angular faces of the plate are ground to be parallel within .0003 inches of each other. The plate changes the rotating action of the shaft into the reciprocating driving force for three pistons. The driving force is applied, through the drive balls and ball seats (shoe discs) to the midpoint of each of the double end pistons.

### Cylinder Block

The cylinder block consists of a front and a rear half. Three piston bores are line bored in each half during production to assure proper alignment and parallelism. The two halves must be serviced as an assembly to assure correct relationship of parts.

### Pistons

The cast aluminum double end pistons (figure 11), have grooves to receive piston rings. Each ring has an oil scraper groove which should face away from the piston face. Two oil return passages are drilled from each ring groove. A notch in the casting web of each piston identifies the end of the piston which should be positioned toward the front end of the compressor. A spherical cavity is located on both inner faces of each piston to receive the piston drive balls.

### Drive Balls

The hardened steel drive balls have a micro-finish. They are manufactured to a .0001 inch spherical tolerance and a .6248 - .6250 inch diameter tolerance.

### Ball Seats

The bronze ball seats have one flat side, which contacts the wobble plate, and one concave surface into which the drive ball fits. Ten seats are provided

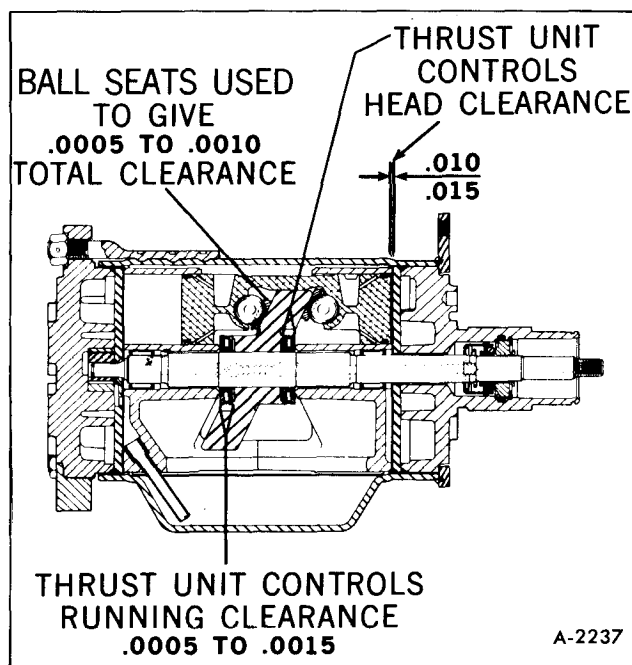

Figure 12—General Running Clearances

in .0005 inch thickness variations including a basic ZERO seat for simple field gauging operations. Seats are marked with their size which corresponds to the last three digits of the piece part number.

Selection from this group must be made to provide .0005 inch to .0010 inch total clearance between the ball seats and the wobble plate at the tightest place throughout its 360° rotation (figure 12).

### Thrust Bearings

The thrust bearings, sandwiched between two thrust races (see below) are located between the shoulders of the wobble plate and the shoulders of both the front and rear cylinder hubs.

### Thrust Races

The steel thrust races are ground to fixed thicknesses. A total of 14 races in increments of .0005 inch thickness are available for field service. As in the case of the ball seats the thrust races will be identified on the part by their thickness, the number on the race corresponding to the last three digits of the piece part number. The FRONT combination of a race, bearing and race is selected to provide the proper head clearance between the top of the cylinder and the underside of the suction and discharge valve plates. The REAR end combination of bearing and races is selected to obtain .0005 inch low limit to .0015 inch high limit running clearance between the hub surfaces of the wobble plate and the front and rear hubs



of the cylinder (figure 12). This allows .001 inch tolerance between the high and low limits.

### Oil Pump Gears

The oil pump gears are made of sintered iron. The inner, or driver gear has a "D" shaped hole in the center which fits over a similar area on the rear of the mainshaft.

### Shell

The compressor shell has a mounting flange on the front end and four threaded studs welded to the outside of the rear end. The oil sump is formed into the shell and a baffle plate is welded over the sump on the inside of the shell.

### Heads

Both front and rear heads have an irregular shaped casting web. These webs provide the necessary seals to the surfaces of the discharge plates and prevent high pressure vapor from flowing into the low pressure cavity.

### Suction Screen

A fine mesh inlet (or suction) screen is located in the low pressure cavity of the rear head. Its purpose is to stop any material which could damage the compressor mechanism.

### Suction Cross-Over Cover

The suction cross-over cover, with its neoprene seal is pressed into the dove-tail cavity in the front and rear cylinder castings to form a passage for the low pressure vapor to flow the rear head of the compressor to the front head.

### Discharge Cross-Over Tube

Since the double acting pistons supply high pressure vapor at both ends of the compressor the discharge tube is needed to supply a path for the high pressure vapor to pass from the front to the rear head. Should the cylinder halves be separated during service operations a service type discharge tube must be substituted.

### Suction Reed Valves

A separate three-reed suction valve disc is assembled to both front and rear heads. These reeds open when the piston is on the intake portion of the stroke to allow the low pressure vapor to flow into the

cylinder. When the piston reverses and begins the compression portion of its stroke the reed valves close against their seats, thus preventing the high pressure vapor from being forced back into the low side of the system.

### Discharge Valves

The two discharge valve plate assemblies act to direct high pressure vapor into the head castings. When the piston reverses into its suction stroke the high pressure on the opposite side of the plate causes the reeds to close thus maintaining the differential of pressure between high and low pressure areas. The discharge plates include the valves and the retainers which prevent the high pressure from distorting the valves during the pressure stroke of the piston.

### Head to Shell Seals

Two large diameter "O" rings internally seal the front and rear heads to the shell. A chamfered edge on the head castings creates a squeezing action between the discharge valve plates, the compressor, and the inside surface of the shell.

### Compressor Connector

Compressor connectors, are attached to the compressor rear head by means of a single bolt and lock washer. All have inlet and outlet connections connected by a strap to form an integral unit.

### Pressure Relief Valve

The pressure relief valve, located on the compressor rear head, is simply a safety valve designed to open automatically if the system pressure should reach a predetermined level high enough to cause system damage. After the pressure drops to a safe level the valve will close. After such an occurrence, the system should be thoroughly checked to discover and correct the cause of the abnormal pressure increase, and then should be purged, evacuated and charged.

## REFRIGERANT LINES

Special refrigerant hose lines are required to carry the refrigerant liquid and vapor between the various system components. The hose line with the smallest diameter is called the high pressure liquid line. It is routed from the condenser or receiver-dehydrator to the evaporator or thermostatic expansion valve. The large diameter hose line connecting

the compressor and evaporator is the low pressure vapor line. The large diameter hose between the compressor and condenser is the high pressure vapor discharge line.

These hoses are constructed with a synthetic material core covered with a woven metal mesh which is, in turn, covered by a woven fabric and coated for extra protection. This hose is so constructed to withstand the extreme pressures and temperatures found in the modern refrigeration system. **None but special refrigerant type hoses should be used.**

All systems make use of swaged type connections (hose to metal fittings) with metal to metal fittings being made using "O" rings. Care must be taken when making these connections that they not be turned down too tightly or damage to the "O" rings may result.

Flexible refrigerant hoses should not be permitted to contact the hot engine manifold nor should they be bent into a radius of less than 10 times their diameter.

## FAN SLIP CLUTCH

A special engine fan is used. It is a seven bladed fan, limited by means of a viscous clutch to a maximum speed of 3200 rpm, regardless of the speed of the engine. The silicone fluid in the clutch transmits only enough torque to drive the fan at this limited speed, thus avoiding excessive noise and power consumption by the fan at higher engine speeds. A temperature modulating device further limits fan speed to 1000 rpm until ambient temperature at the modulating device reaches 140°F. at which time fan speed will be allowed to increase to 3200 rpm. Some adjustment of the modulating device is possible.

## CONDENSER

The condenser receives the high pressure, high temperature gas which is pumped from the compressor and condenses it into a high pressure high temperature liquid. The heated gas which enters near the top of the condenser is cooled by giving off heat to the metal surfaces of the condenser. The heat is then extracted from these metal surfaces by the ram air passing over the condenser.

The condenser is located in front of the engine cooling system radiator so that it receives a high volume of air from the movement of the vehicle and from the engine fan.

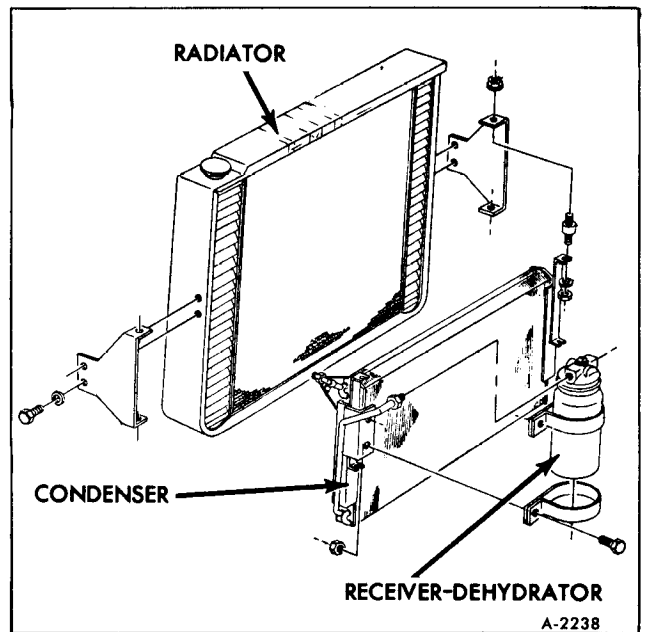

Figure 13—Condenser and Receiver-Dehydrator

The condenser is similar in design to the ordinary radiator but is designed to withstand much higher pressures (figure 13).

## RECEIVER-DEHYDRATOR

The receiver-dehydrator (figure 13), sometimes called the receiver-drier or just drier, is so called because of its function of receiving liquid refrigerant from the condenser and, by means of a dehydrating agent, removes any water present from it. This chemical compound is called a desiccant. The desiccant is held in place in a felt bag in the drier. Average receiver-drier desiccants collect and hold about 50 drops of water. This may not seem like much until you realize that one drop of water can block the whole air conditioning system.

The drier also filter-traps any foreign matter which may have entered the system during assembly or during any service work. This is accomplished by means of a fine wire screen.

Still another function of the receiver dehydrator is to act as a reservoir to furnish a constant column of liquid refrigerant to the expansion valve at all times. Since the entering liquid refrigerant may have some gas in it, the tank acts as a separator. The gas will tend to rise and the liquid will drop to the bottom. This is why the pick-up tube extends to the bottom of the tank insuring gas free liquid R-12 to the expansion valve. The storage of the refrigerant is temporary, and is dependent on the demand placed on it by the expansion valve.

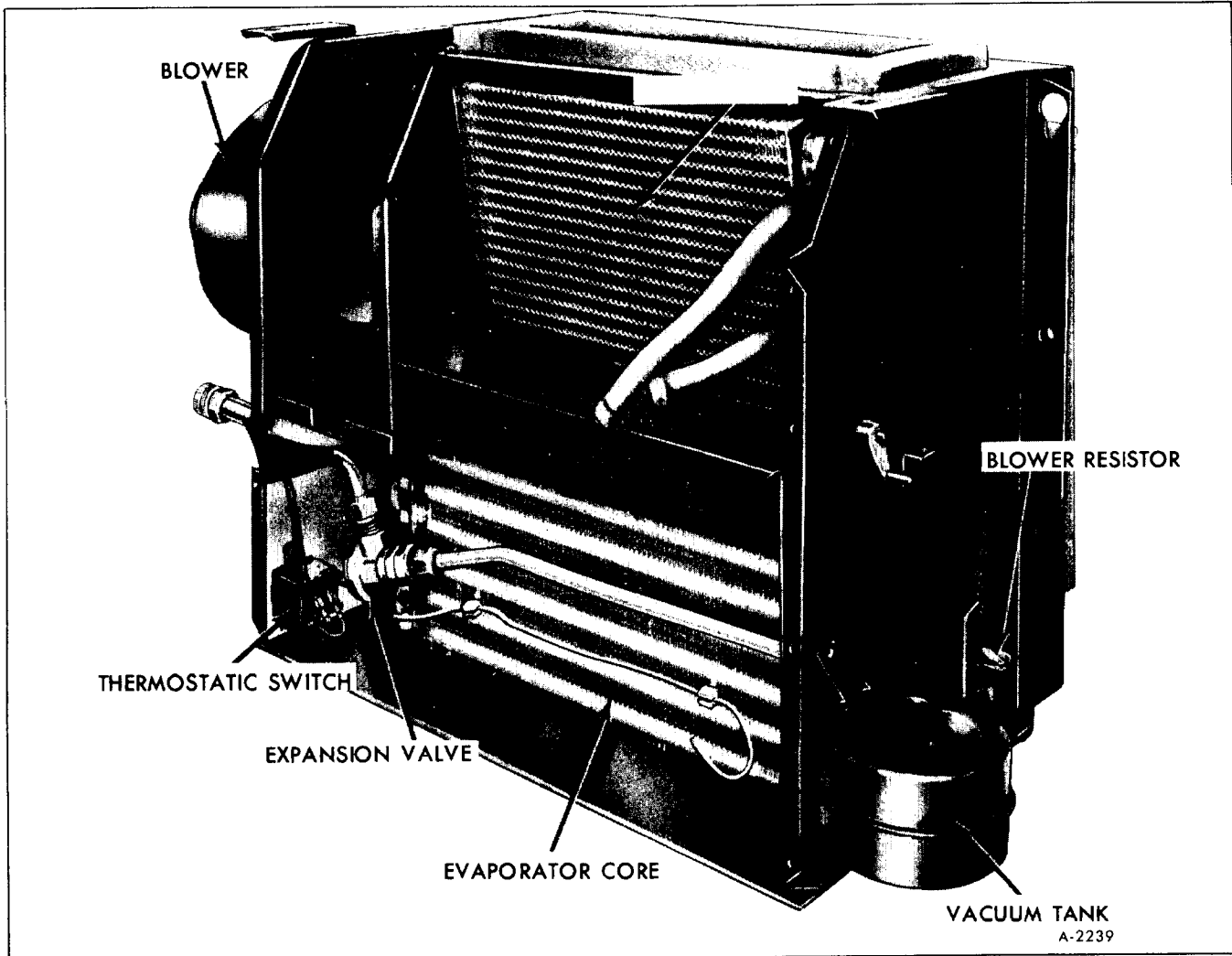

Figure 14—Evaporator Housing Components

While having no real function to perform in the system, the sight glass is a valuable aid in determining whether or not the refrigerant charge is sufficient and for eliminating some guess work in diagnosing difficulties. The sight glass, is built into the receiver-dehydrator outlet connection and is designed and located so that a shortage of refrigerant at this point will be indicated by the appearance of bubbles beneath the glass. The dust cap provided should be kept in place when the sight glass is not in use.

## THERMOSTATIC EXPANSION VALVE

The valve consists primarily of the power element, body, actuating pins, seat and orifice. At the high pressure liquid inlet, is a fine mesh screen which prevents dirt, filings or other foreign matter from entering the valve orifice.

The valve is located inside the evaporator housing (See figure 14).

When the valve is connected in the system, high pressure liquid refrigerant enters the valve through the screen from the receiver-dehydrator or condenser and passes on to the seat and orifice. Upon passing through the orifice the high pressure liquid becomes low pressure liquid. The low pressure liquid leaves the valve and flows into the evaporator core where it absorbs heat from the evaporator core and changes to a low pressure vapor, and leaves the evaporator core as such. The power element bulb is clamped to the low pressure vapor line just beyond the outlet of the evaporator (figure 15).

The operation of the valve is quite simple. It is a matter of controlling opposing forces produced by a spring and the refrigerant pressures. For example: The pressure in the power element is trying to push the seat away from the orifice, while the adjusting

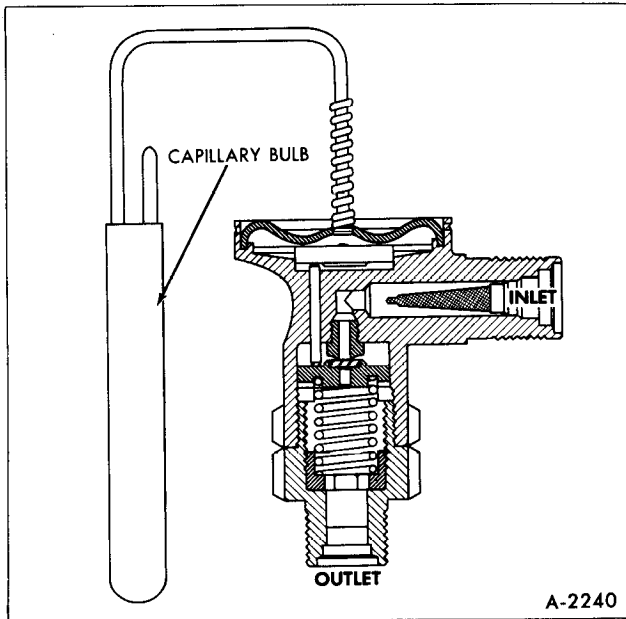

Figure 15—Expansion Valve Cross-Section

spring is trying to force the seat toward the orifice. These opposing pressures are established in the design of the valve so that during idle periods the adjusting spring tension and the refrigerant pressure in the cooling coil are always greater than the opposing pressure in the power element. Therefore, the valve remains closed. When the compressor is started, it will reduce the pressure and temperature of the refrigerant in the cooling coil to a point where the vapor pressure in the power element becomes the stronger. The seat then moves off the orifice and liquid starts to flow through the valve orifice into the cooling coil.

The purpose of the power element is to help determine the quantity of liquid that is being metered into the cooling coil. As the temperature of the low pressure line changes at the bulb, the pressure of the vapor in the power element changes, resulting in a change of the position of the seat. For example, if the cooling coil gets more liquid than is required, the temperature of the low pressure line is reduced and the resultant lowering of the bulb temperature reduces the pressure of the vapor in the power element, allowing the seat to move closer to the orifice. This immediately reduces the amount of liquid leaving the valve. Under normal operation, the power element provides accurate control of the quantity of refrigerant to the cooling coil.

To employ our tire pump analogy once more for clarity, it is the same situation that would exist if you were inflating a tire with a very slow leak. Providing you pumped the air into the tire as fast as it leaked out, you would be able to maintain pressure even

though the air would merely be circulating through the tire and leaking out through the puncture.

## EVAPORATOR

The function of the evaporator (figure 14) is to cool and dehumidify the air flow before it enters the passenger compartment. The evaporator assembly consists of an aluminum core enclosed in a sheet metal housing located in the front of the Motor Home chassis. Two water drain holes are located in the bottom of the housing. Two refrigerant lines are connected to the sides of the evaporator core: the small inlet line on the right, and the larger outlet line on the left.

The temperature sensing bulb of the expansion valve is clamped to the outlet pipe of the evaporator core. The high pressure liquid refrigerant, after it is metered through the expansion valve, passes into the evaporator core where it is allowed to expand under reduced pressure. As a result of the reduced pressure the refrigerant begins to expand and return to the original gaseous state. To accomplish this transformation it begins to boil.

The boiling action of the refrigerant demands heat. To satisfy the demand for heat, the air passing over the core gives up heat to the evaporator and is subsequently cooled.

## LOW REFRIGERANT CHARGE PROTECTION SYSTEM

The compressor discharge pressure switch (figure 16) performs the function of shutting off the compressor when it senses low refrigerant pressure. The switch is located in the evaporator inlet line (high pressure). The switch electrically is wired in series between the compressor clutch and the master switch on the control. When the switch senses low pressure it breaks contact and opens the circuit to the compressor clutch, thus shutting off the A/C system and preventing compressor failure or seizure.

The compressor discharge pressure switch also performs the function of the ambient switch as the pressure at the switch varies directly with ambient temperatures. The compressor should not run below 25°F. ambient or 37 psi at the switch. The compressor should run in A/C modes above 45°F. ambient or 42 psi at the switch.

The switch interacts with other switches so that in an A/C system where the compressor will not op-

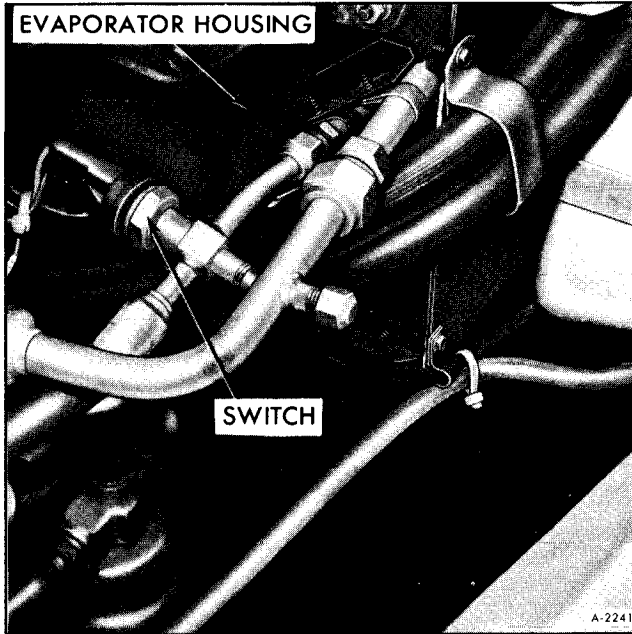

Figure 16-Compressor Discharge Pressure Switch

erate above 45° ambient the following components should be checked for continuity:

1. Compressor discharge pressure switch.
2. Master switch (on control head).

If both switches show proper continuity, check the harness for shorts or improper ground conditions. The switch also contains the high pressure line service ports.

## ELECTRICAL COMPONENTS

### COMPRESSOR CLUTCH ASSEMBLY

The clutch assembly (figure 10) consists of the coil, pulley and armature. The coil is basically an electro-magnetic device charged by the battery. When energized, it sends a magnetic force through the soft iron in the pulley, which is constantly turning as a result of being belt driven by the engine, to the armature. The armature is keyed to the compressor shaft. When magnetically energized the armature is pulled into the pulley causing the compressor to be activated.

### BLOWER

The blower (figure 17) is simply a device for moving air. The blower used in the GMC Motor Home

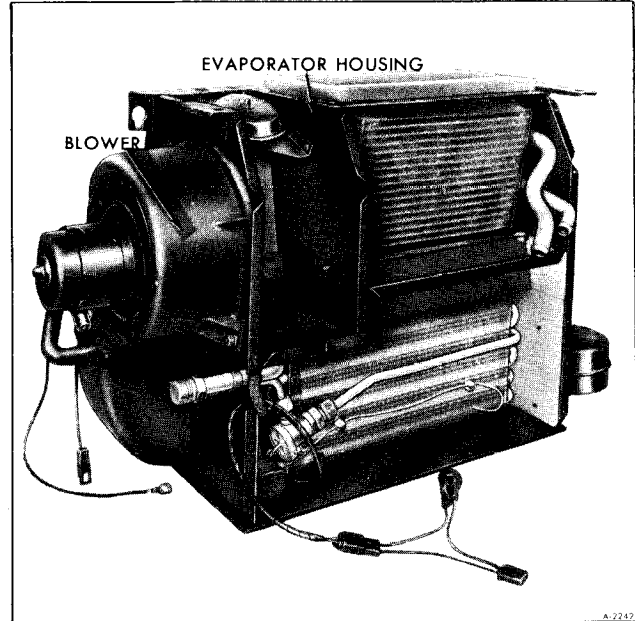

Figure 17-Blower Location

is a centrifugal type fan which forces air across the evaporator and/or heat cores to the vehicle interior.

### THERMOSTATIC SWITCH

The thermostatic switch (figure 14) is basically a bimetal switch which is controlled by a sensing tube across the outlet of the evaporator core. As the evaporator cools the sensing tube the bimetal switch turns off the clutch and disengages the compressor until the tube becomes warm enough to turn the compressor back on.

### BLOWER SWITCH, RELAY & RESISTOR

The blower switch, blower relay and the blower

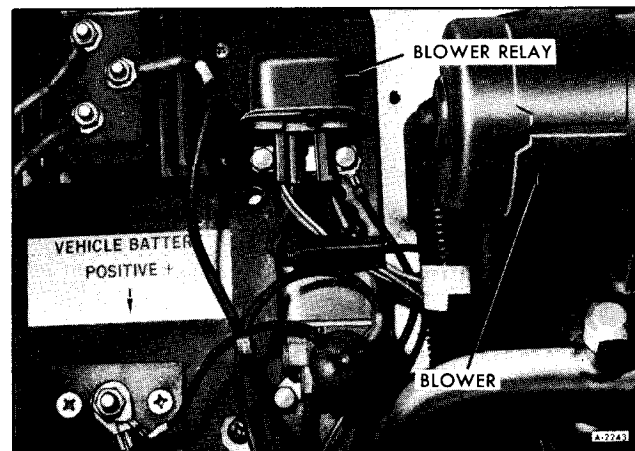
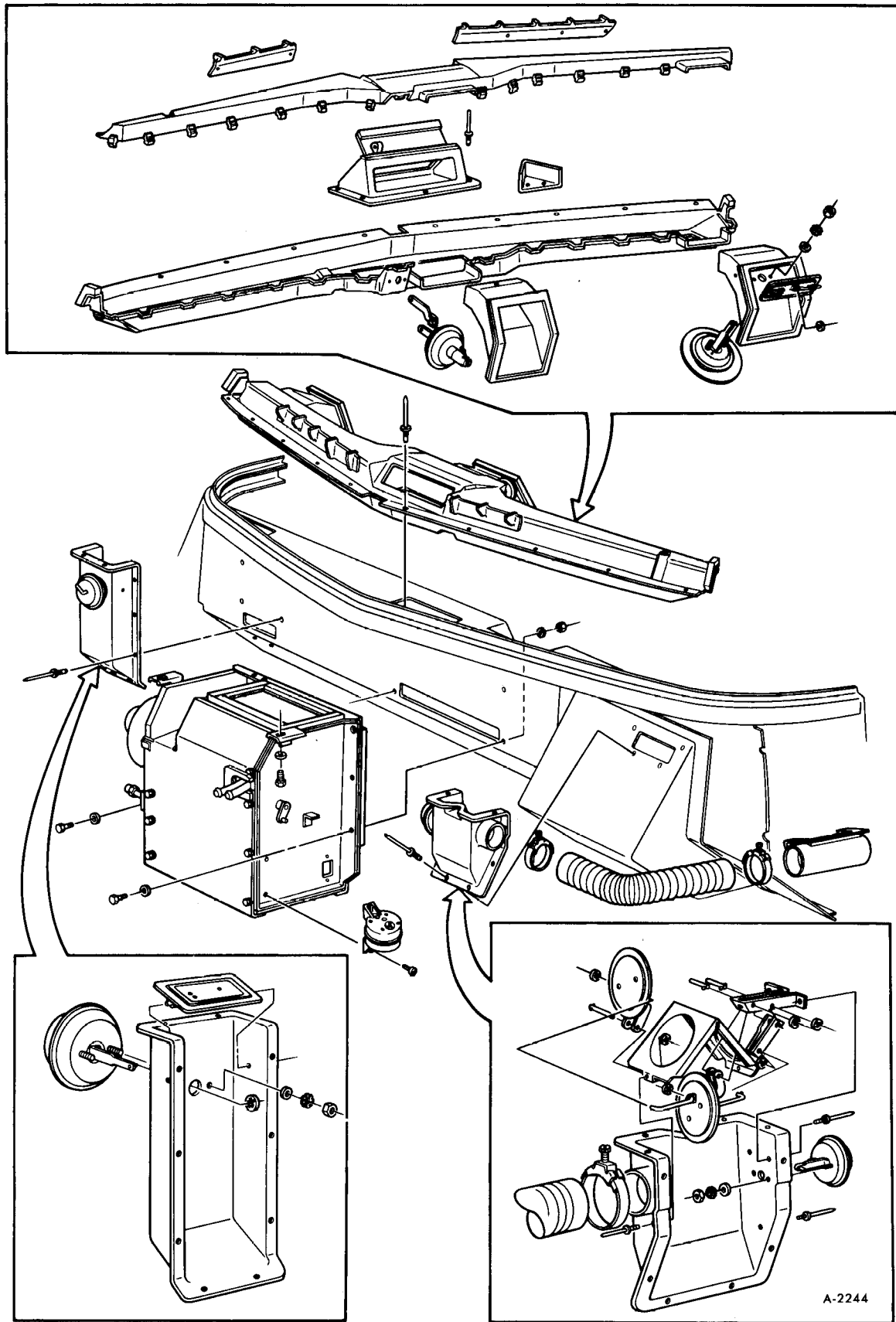

Figure 18-Blower Relay



A-2244

Figure 19-Vacuum Ducts and Controls

resistor must be discussed together because of their interrelations with each other. The blower switch located on the instrument panel regulates low, medium and high blower speeds through a blower resistor system. This resistor (figure 14) regulates the amount of current fed to the blower thereby regulating the blower speed. The blower relay (figure 18) provides the proper connections for the low and medium speeds through the resistor assembly and direct battery current to the blower for high speed.

## VACUUM COMPONENTS

The vacuum system (figure 19) consists of three basic components:

1. Vacuum tank.
2. Modes or vacuum switches.
3. Control Panel.

The vacuum tank is simply a reservoir of vacuum to be utilized when engine vacuum drops too low to effectively actuate the vacuum components.

The modes are diaphragm switches which open and close the various doors in the air movement system allowing "Heat" "Air Conditioning", "Defrost" and "Vent" as shown on the control panel (figure 21).

The control panel consists of a temperature valve and a select valve (See figure 20). This is the control center for directing vacuum through vacuum lines to

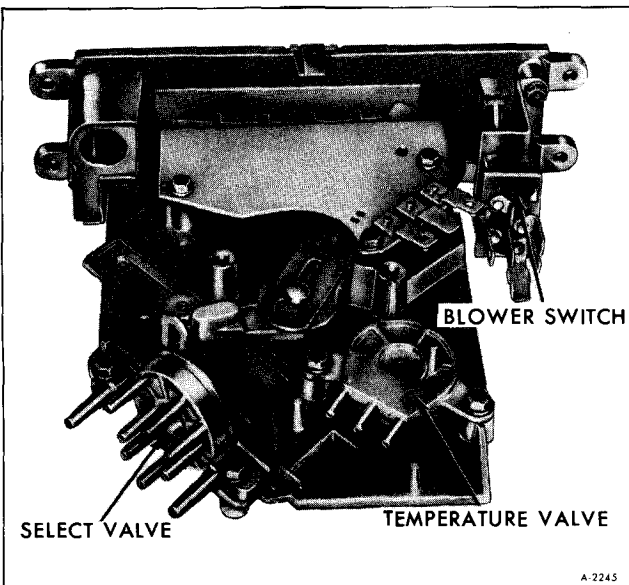

Figure 20—Control Panel Components

the different modes to achieve the temperatures desired for passenger and driver comfort. More information concerning the vacuum system and the routing of the lines and operation of the modes will be covered later in this section.

## PRIMARY CAUSES OF SYSTEM FAILURE

### Leaks

A shortage of refrigerant causes oil to be trapped in the evaporator. Oil may be lost with the refrigerant at point of leakage. Both of these can cause compressor seizure.

Oil circulates in the globules with the vapor. It leaves the compressor by the action of the pistons and mixes with the refrigerant liquid in the condenser. The oil then enters the evaporator with the liquid and, with the evaporator properly flooded, is returned to the compressor through the low pressure line. Some of the oil returns as globules in the vapor but more importantly, it is swept as a liquid along the walls of the tubing by the velocity of the vapor. If the evaporator is starved, the oil cannot return in sufficient quantities to keep the compressor properly lubricated.

### High Temperature and Pressure

An increase in temperature causes an increase in pressure. This accelerates chemical instability in clean systems. Other results are brittle hoses, "O" ring gaskets, and by-pass valve diaphragms with possible decomposition, broken compressor discharge reeds, and seized compressor bearings.

A fundamental law of nature accounts for the fact that when a substance, such as a refrigerant, is increased in temperature, its pressure is also increased.

Any chemical reactions caused by contaminants already in the system are greatly accelerated as the temperature increases. A 15° rise in temperature doubles the chemical action.

While temperature alone can cause the synthetic rubber parts to become brittle and possibly to decompose, the increased pressure can cause them to rupture or blow.

As the temperature and pressure increases, the stress and strain on the discharge reeds also increases. This can result in broken reeds. Due to the effect of the contaminants caused by high tempera-

ture and pressure, compressor bearings can be caused to seize.

High temperature and pressure is also caused by air in the system.

### **Air in the System**

Air results from a discharged system or careless servicing procedures. This reduces system capacity and efficiency and causes oxidation of oil into gum and varnish.

When a leak causes the system to become discharged, the resulting vacuum within the system will cause air to be drawn in. Air in a system is a non-condensable gas and will build up in the condenser as it would in an air compressor tank. The resultant heat produced will contribute to the conditions discussed previously.

Many systems are contaminated and also reduced in capacity and efficiency by careless servicing procedures.

Too frequently, systems which have been open to the atmosphere during service operations have not been properly purged or evacuated. Air is also introduced into the system by unpurged gauge and charging lines. Remember that any air in the system is too much air.

### **Poor Connections**

Hose clamp type fittings must be properly made. Hose should be installed over the sealing flanges and with the end of the hose at the stop flange. The hose should never extend beyond the stop flange. Locate the clamp properly and torque as recommended. Be especially careful that the sealing flanges are not nicked or scored or a future leak will result.

When compression fittings are used, over-tightening can cause physical damage to the "O" ring gasket and will result in leaks. The use of torque and backing wrenches is highly recommended. When making a connection with compression fittings, the gaskets should always be first placed over the tube before inserting it in the connection.

Another precaution - inspect the fitting for burrs which can cut the "O" ring.

### **Restrictions**

Restrictions may be due to powdered desiccant or dirt and foreign matter. This may result in starved evaporator and loss of cooling, high temperature at the bypass hose, or a seized compressor.

When the amount of moisture in a system sufficiently exceeds the capacity of the desiccant, it can break down the desiccant and cause it to powder. The powder passes through the dehydrator screen with the refrigerant liquid and is carried to the expansion valve screen. While some of it may pass through the valve screen into the evaporator, it may quickly build up to cause a restriction.

Due to the fact that sufficient oil then cannot be returned to the compressor, it may seize.

### **Dirt**

Dirt, which is any foreign material, may come from cleaner residues, cutting, machining, or preserving oils, metal dust or chips, lint or dust, loose rust, soldering or brazing fluxes, paint or loose oxide scale. These can also cause seized bearings by abrasion or wedging, discharge and expansion valve failure, decomposition of refrigerant and oil, or corrosion of metal parts.

### **Corrosion**

Corrosion and its by-products can restrict valve and drier screens, roughen bearing surfaces or hasten fatiguing of discharge reeds. This can result in high temperature and pressure, decomposition or leaks. In any event, this means a damaged compressor.

From this, we can see the vicious circle that can be produced in a refrigerating system to cause its failure. Corrosion can be the indirect cause of leaks and leaks can be the direct cause of corrosion. We can also see the important role servicemen play in maintaining chemical stability.

The major cause of corrosion is moisture.

### **Moisture**

Moisture is the greatest enemy of refrigerating systems. Combined with metal, it produces oxide, Iron Hydroxide, and Aluminum Hydroxide. Combined with R-12, it produces Carbonic acid, Hydrochloric acid, and Hydro-fluoric acid. Moisture can also cause freeze-up of an expansion valve and powdered desiccant.

Although high temperature and dirt are responsible for many difficulties in refrigerating systems, in most instances it is the presence of moisture in the system that accelerates these conditions. It can be said, therefore, that moisture is the greatest problem of all. The acids that it produces, in combination with both the metals and the refrigerant, causes damaging corrosion. While the corrosion may not form



as rapidly with R-12 as with some other refrigerants, the eventual formation is as damaging.

If the operating pressure and temperature in the evaporator is reduced to the freezing point, moisture in the refrigerant can collect at the orifice of the expansion valve and freeze. This temporarily restricts the flow of liquid causing erratic cooling.

As previously mentioned, moisture in excess of the desiccant's capacity can cause it to powder.

### Points to Remember

That the inside of the refrigerant system is completely sealed from the outside world. If that seal remains broken at any point – the system will soon be damaged.

That complete and positive sealing of the entire system is vitally important and that this sealed condition is absolutely necessary to retain the chemicals and keep them in a pure and proper condition.

That all parts of the refrigerant system are under pressure at all times, whether operating or idle, and that any leakage points are continuously losing refrigerant and oil.

That the leakage of refrigerant can be so silent that the complete charge may be lost without warning.

That refrigerant gas is heavier than air and will rapidly drop to the floor as it flows from a point of leakage.

That the pressure in the system may momentarily become as high as 480 lbs. per square inch.

That the total refrigerant charge circulates through the entire system at least once each minute.

That the compressor is continually giving up some lubricating oil to the circulating refrigerant and depends upon oil in the returning refrigerant for continuous replenishment. Any stoppage or major loss of refrigerant will therefore damage the compressor.

That the extreme internal dryness of a properly processed system is a truly desert condition, with the drying material in the receiver or accumulator holding tightly onto the tiny droplets of residual moisture.

That the attraction of the drying material for moisture is so powerful that if the receiver or accumulator is left open, moisture will be drawn in from the outside air.

That water added to the refrigerant will start chemical changes that can result in corrosion and eventual breakdown of the chemicals in the system. Hydrochloric acid is one result of an R-12 mixture with water.

That air in the refrigerant system may start reactions that can cause malfunctions.

That the drying agent in the receiver-dehydrator is Activated Silica Alumina.

That the inert gas in the expansion valve-capillary line is carbon dioxide.

## CONTROLS (FIGURE 21)

Combined air conditioning and heating system controls are located on the instrument panel in the upper right-hand corner. There are three separate controls; "FAN" lever, to control speed of blower; "OFF," "A/C," "VENT," "HEATER," "DEF" lever to control direction of air flow and which system is to be operated; "RECIRC," "COLD," "HOT" lever to control the temperature of the air. The three levers may be placed in many combined positions to deliver the climate conditions most desirable at any given time.

## OPERATION

"FAN" – the fan switch has four positions; "OFF" and three blower speeds ranging from "LO" to "HI." The fan will not operate unless the top lever has been moved from the "OFF" position, and in order to operate the fan in the "HI" position the engine must be running.

"OFF," "A/C," "VENT," "HEATER," "DEF" – With the lever in the "OFF" position the system is off. With the lever in the "A/C" position (and the "RECIRC," "COLD," "HOT" lever at "RECIRC," position) the air conditioning system is activated. This position uses 80% recirculated air.

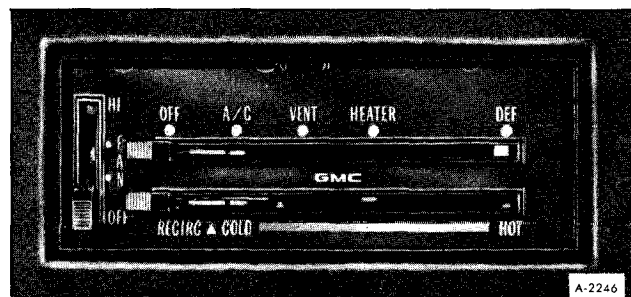

Figure 21—Air Conditioning Controls

This setting will provide maximum cooling. In combination with "A/C" setting moving the temperature lever to the "COLD" position provides 100% outside air. Further movement of the temperature lever to the right (toward "HOT" position) will heat the dehumidified air to the desired temperature. The "FAN" switch can be set to meet air flow requirements.

With the lever in the "VENT" position, 100% outside air enters the driver's compartment. This setting is for use during periods of less severe heat and humidity, air flow is identical to air flow in "A/C" position, however, the air conditioning compressor is not operating. Temperature of incoming air may be controlled by moving the temperature lever to the desired position. Any one of the three blower speeds may be selected.

With the lever in the "HEATER" position, air will flow through the heater floor distributor outlet (with a slight flow of air to the defroster outlet). For maximum heat, move the temperature lever to "HOT" position and "FAN" switch lever to "HI" position. Heating system output can be varied by moving temperature lever and "FAN" lever to different positions.

With the lever in "DEF" position, system operates the same as in the "HEATER" position except most of the air flow will be through the defroster outlets at the windshield.

"RECIRC," "COLD," "HOT" - This lever, used in conjunction with the system selector lever ("OFF," "A/C," "VENT," "HEATER," "DEF") and the "FAN" switch lever, will control the temperature of the output air being distributed.

**CAUTION:** Operate in "DEF" position for 30 seconds before switching to "A/C." This will remove humid air from the system and minimize rapid fogging of the glass which can occur if humid air is blown onto a cool windshield.

Clear windshield, rear window, outside mirrors, and all side windows of ice and snow before driving vehicle.

Operate blower on "HI" for a few seconds before moving the vehicle, to clear the air intakes of snow.

## GENERAL INFORMATION

In any vocation or trade, there are established procedures and practices that have been developed after many years of experience. In addition, occupational hazards may be present that require the observation of certain precautions or use of special tools and equipment. Observing the procedures, practices and precautions of servicing refrigeration equipment will greatly reduce the possibilities of damage to the customers' equipment as well as virtually eliminate the element of hazard to the serviceman.

### PRECAUTIONS IN HANDLING REFRIGERANT-12

Refrigerant-12 is transparent and colorless in both the gaseous and liquid state. It has a boiling point of 21.7°F below zero and, therefore, at all normal temperatures and pressures it will be a vapor. The vapor is heavier than air, and is noninflammable, nonexplosive, nonpoisonous (except when in contact with an open flame) and noncorrosive (except when in contact with water).

**WARNING: THE FOLLOWING PRECAUTIONS IN HANDLING R-12 SHOULD BE OBSERVED AT ALL TIMES.**

1. Refrigerant should not be exposed to the radiant heat from the sun since the resulting increase in pressure may cause the safety valve to release or the cylinder or can to burst.

2. Cylinders or disposable cans should never be subjected to high temperature when adding refrigerant to the system. In most instances, heating the cylinder or can is required to raise the pressure in the container higher than the pressure in the system during the operation. It would be unwise to place the cylinder on a gas stove, radiator or use a blow torch while preparing for the charging operation, for a serious accident can result. Remember, high pressure means that great forces are being exerted against the walls of the container. A bucket of warm water, not over 125°F, or warm wet rags round the container is all the heat that is required.

3. Do not weld or steam clean on or near the system. Welding or steam cleaning can result in a dangerous pressure buildup in the system.

4. Discharging large quantities of R-12 into a room can usually be done safely as the vapor would produce no ill effects; however, in the event of an accidental rapid discharge of the system, it is recommended that inhalation of large quantities of R-12 be

avoided. This caution is especially important if the area contains a flame producing device such as a gas heater. While R-12 normally is nonpoisonous, heavy concentrations of it in contact with a live flame will produce a toxic gas. The same gas will also attack all bright metal surfaces.

5. Protection of the eyes is of vital importance! When working around a refrigerating system, an accident may cause liquid refrigerant to hit the face. If the eyes are protected with goggles or glasses, no serious damage can result. Just remember, any R-12 liquid that touches you is at least 21.7°F below zero. If R-12 liquid should strike the eyes, here is what to do:

A. Keep calm.

B. Do not rub the eyes. Splash the affected area with quantities of cold water to gradually get the temperature above the freezing point. The use of mineral, cod liver or an antiseptic oil is important in providing a protective film to reduce the possibility of infection.

C. As soon as possible, call or consult an eye specialist for immediate and future treatment.

## PRECAUTIONS IN HANDLING REFRIGERANT LINES

**CAUTION:** *The following precautions should be observed when handling refrigerant lines:*

1. All metal tubing lines should be free of kinks, because of the restriction that kinks will offer to the flow of refrigerant. The refrigeration capacity of the entire system can be greatly reduced by a single kink.
2. The flexible hose lines should never be bent to a radius of less than 10 times the diameter of the hose.
3. The flexible hose lines should never be allowed to come within a distance of 2-1/2" of the exhaust manifold.
4. Flexible hose lines should be inspected at least once a year for leaks or brittleness. If found brittle or leaking they should be replaced with new lines.
5. Use only new lines that have been sealed during storage.
6. When disconnecting any fitting in the refrigeration system, the system must first be discharged of all refrigerant. However, proceed very cautiously re-

gardless of gauge readings. Open very slowly, keeping face and hands away so that no injury can occur if there happens to be liquid refrigerant in the line. If pressure is noticed when fitting is loosened, allow it to bleed off as described under "Purging the System" in this section.

**WARNING: ALWAYS WEAR SAFETY GOGGLES WHEN OPENING REFRIGERANT LINES.**

7. In the event any line is opened to atmosphere, it should be immediately capped to prevent entrance of moisture and dirt.

8. The use of the proper wrenches when making connections on "O" ring fittings is important. The use of improper wrenches may damage the connection. The opposing fitting should always be backed up with a wrench to prevent distortion of connecting lines or components. When connecting the flexible hose connections it is important that the swaged fitting and the flare nut, as well as the coupling to which it is attached, be held at the same time using three different wrenches to prevent turning the fitting and damaging the ground seat.

9. "O" rings and seats must be in perfect condition. A burr or piece of dirt may cause a leak.

10. Sealing beads on hose clamp connections must be free of nicks and scratches to assure a perfect seal.

## MAINTAINING CHEMICAL STABILITY IN THE REFRIGERATION SYSTEM

The metal internal parts of the refrigeration system and the refrigerant and oil contained in the system are designed to remain in a state of chemical stability as long as pure R-12 and uncontaminated refrigeration oil is used in the system.

However, when abnormal amounts of foreign materials, such as dirt, air or moisture are allowed to enter the system, the chemical stability may be upset. When accelerated by heat, these contaminants may form acids and sludge and eventually cause the breakdown of components within the system. In addition, contaminants may affect the temperature-pressure relationship of R-12, resulting in improper operating temperature and pressures and decreased efficiency of the system.

*The following general practices should be observed to ensure chemical stability in the system:*

1. Whenever it becomes necessary to disconnect a refrigerant or gauge line, it should be immediately capped. Capping the tubing will also prevent dirt and foreign matter from entering.

2. Tools should be kept clean and dry. This also includes the gauge set and replacement parts.

3. When adding oil, the container should be exceptionally clean and dry due to the fact that the refrigeration oil in the container is as moisture-free as it is possible to make it; therefore, it will quickly absorb any moisture with which it comes in contact. For this same reason the oil container should not be opened until ready for use and then it should be capped immediately after use.

4. When it is necessary to open a system, have everything you will need ready and handy so that as little time as possible will be required to perform the operation. Don't leave the system open any longer than is necessary.

5. Finally, after the operation has been completed and the system sealed again, air and moisture should be evacuated from the system before recharging.

## CHARGING STATION J-24410

This portable air conditioner service station (figure 22) features the new J-24364 High Capacity Vacuum Pump. Utilization of J-24364 enables the J-24410 service station to out-perform all competitive stations in the automotive field today.

The capacity of the J-24364 is three cubic feet per minute; four times that of the J-5428-03 which pumps at a rate of .8 cubic feet per minute. A vented exhaust aids in the removal of moisture at a much faster rate.

With the added increases in capacity the new J-24410 will enable a serviceman to perform the evacuation procedure in an automotive air conditioning system in one third less time. This of course is a money saving feature.

The J-24410 incorporates two compound gauges. The second compound gauge is used to permit checking of other Motor Home manufacturer's systems at the evaporator pressure release valve. The CMN fast flow manifold incorporates a new O ring stem which permits the manifold to be opened or closed in two and a half turns.

This station is equipped with a controlled heated cylinder which assures a complete charge into the high pressure side of the compressor. This feature reduces the charging time considerably and enables

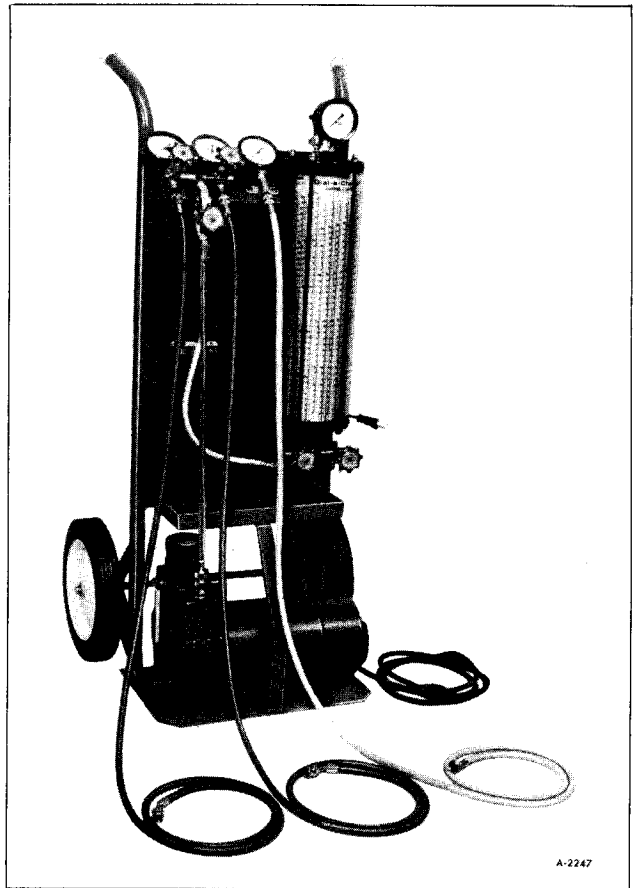

Figure 22—Charging Station J-24410

a complete and accurately measured charge without running the engine!

The line from the manifold to the pump is 3/8" I.D. copper tube which is a larger I.D. for less restriction on pull down. The cylinder is graduated for Refrigerant-12 and Refrigerant-22. Refrigerant-22 is used in some of the refrigerant systems on recreational vehicles. Also the cylinder has a heating element to provide a positive pressure advantage to overcome system pressure equalization.

## GAUGE SET

The gauge set is an integral part of the Charging Station. It is used when purging, evacuating, charging or diagnosing trouble in the system. The gauge at the left is known as the low pressure gauge. The face is graduated into pounds of pressure and, in the opposite direction, in inches of vacuum. This is the gauge that should always be used in checking pressures on the low pressure side of the system. When all parts of the system are functioning properly the refrigerant pressure on the low pressure side never

falls below 0 pounds pressure. However, several abnormal conditions can occur that will cause the low pressure to fall into a partial vacuum. Therefore, a low pressure gauge is required.

The high pressure gauge is used for checking pressures on the high pressure side of the system.

The hand shutoff valves on the gauge manifold do not control the opening or closing off of pressure to the gauges. They merely close each opening to the center connector and to each other. During most diagnosing and service operation, the valves must be closed. Both valves will be open at the same time during purging, evacuating and charging operations.

The charging station provides two flexible lines for connecting the gauge set to the system components.

## VACUUM PUMP

A vacuum pump should be used for evacuating air and moisture from the air conditioning system.

The vacuum pump (figure 22), is a component part of Charging Station described previously.

**CAUTION:** *The following precautions should be observed relative to the operation and maintenance of this pump:*

1. Make sure dust cap on discharge outlet of vacuum pump is removed before operating.
2. Keep all openings capped when not in use to avoid moisture being drawn into the system.
3. Oil should be changed after every 250 hours of normal operation.

To change oil, simply unscrew hex nut located on back side of pump, tilt backward and drain out oil. Recharge with 8 ounces of vacuum pump oil Frigidaire 150 or equivalent. If you desire to flush out the pump, use this same type clean oil. Do not use solvent. Improper Lubrication will shorten pump life.

4. If this pump is subjected to extreme or prolonged cold, allow it to remain indoors until oil has reached approximate room temperature. Failure to warm oil will result in a blown fuse.

5. A five ampere time delay cartridge fuse has been installed in the common line to protect the windings of the compressor. The fuse will blow if an excessive load is placed on the pump. In the event the

fuse is blown, replace with a five ampere time delay fuse. **Do not use a substitute fuse** as it will result in damage to the starting windings.

6. If the pump is being utilized to evacuate a burnt-out system, a filter must be connected to the intake fitting to prevent any sludge from contaminating the working parts, which will result in malfunction of the pump.

7. Do not use the vacuum pump as an air compressor.

## LEAK TESTING THE SYSTEM

Whenever a refrigerant leak is suspected in the system or a service operation performed which results in disturbing lines or connections, it is advisable to test for leaks. Common sense should be the governing factor in performing any leak test, since the necessity and extent of any such test will, in general, depend upon the nature of the complaint and the type of service performed on the system.

## LEAK DETECTOR

Tool J-6084 (figure 23) is a propane gas-burning torch which is used to locate a leak in any part of the system. Refrigerant gas drawn into the sampling tube attached to the torch will cause the torch flame

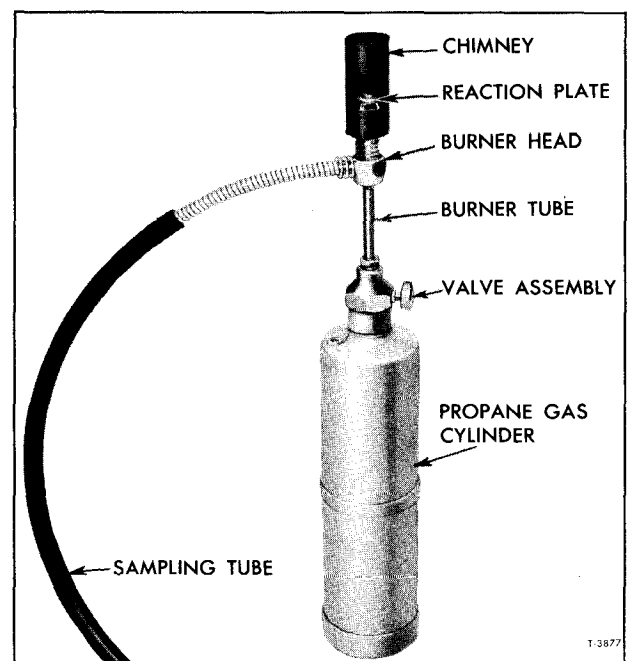

Figure 23—Leak Detector J-6084

to change color in proportion to the size of the leak. Propane gas fuel cylinders used with the torch are readily available commercially throughout the country.

**WARNING: DO NOT USE LIGHTED DETECTOR IN ANY PLACE WHERE COMBUSTIBLE OR EXPLOSIVE GASES, DUSTS OR VAPORS MAY BE PRESENT.**

## OPERATING DETECTOR

1. Determine if there is sufficient refrigerant in the system for leak testing.
2. Open control valve only until a low hiss of gas is heard, then light gas at opening in chimney.
3. Adjust flame until desired volume is obtained. This is most satisfactory when blue flame is approximately 3/8" above reactor plate. The reaction plate will quickly heat to a cherry red.
4. Explore for leaks by moving the end of the sampling hose around possible leak points in the system. Do not pinch or kink hose.

**NOTE:** Since R-12 is heavier than air, it is good practice to place open end of sampling tube immediately below point being tested, particularly in cases of small leaks.

**WARNING: DO NOT BREATHE THE FUMES THAT ARE PRODUCED BY THE BURNING OF R-12 GAS IN THE DETECTOR FLAME, SINCE SUCH FUMES CAN BE TOXIC IN LARGE CONCENTRATIONS.**

5. Watch for color changes. The color of the flame which passes through the reaction plate will change to green or yellow-green when sampling hose draws in very small leaks of R-12. Large leaks will be indicated by a change in color to a brilliant blue or purple; when the sampling hose passes the leaks, the flame will clear to an almost colorless pale-blue again. Observations are best made in a semidarkened area. If the flame remains yellow when unit is removed from leak, insufficient air is being drawn in or the reaction plate is dirty.

**NOTE:** A refrigerant leak in the high pressure side of the system may be more easily detected if the system is operated for a few minutes, then shut off and checked immediately (before system pressures equalize). A leak on the low pressure side may be more easily detected after the engine has been shut off for several minutes (system

pressures equalized); this applies particularly to the front seal.

## AVAILABILITY OF REFRIGERANT-12

Refrigerant-12 is available in 30 lb. and in 15 oz. disposable containers.

Normally, air conditioning systems are charged making use of the Charging Station which uses the 30 lb. container. Evacuating and charging procedures are noted later in this section.

The 15 oz. disposable cans are generally used for miscellaneous operations such as flushing.

**WARNING: THE FOLLOWING PRECAUTIONS SHOULD BE OBSERVED WHEN ADDING REFRIGERANT TO A SYSTEM USING 15 OZ. DISPOSABLE CANS:**

1. Do not charge while compressor system is hot.
2. Empty container completely before disposing.
3. Use opening valves designed for use with container - follow valve manufacturer's directions carefully.
4. Always use pressure gauges before and during charging.
5. NEVER connect on high pressure side of system or to any system having a pressure higher than indicated on refrigerant containers.
6. If inexperienced, seek professional assistance.

## COMPRESSOR OIL

Special refrigeration lubricant should be used in the system. This oil is as free from moisture and contaminants as it is possible to attain by human processes. This condition should be preserved by immediately capping the bottle when not in use.

See "Air Conditioning System Capacities" for the total system oil capacity.

Due to the porosity of the refrigerant hoses and connections, the system refrigerant level will show a definite drop after a period of time. Since the compressor oil is carried throughout the entire system mixed with the refrigerant, a low refrigerant level will cause a dangerous lack of lubrication. Therefore

the refrigerant charge in the system has a definite tie-in with the amount of oil found in the compressor and an insufficient charge may eventually lead to an oil build-up in the evaporator.

serial number plate on top of the compressor. The serial number consists of a series of numbers and letters. This serial number should be referenced on all forms and correspondence related to the servicing of this assembly.

## COMPRESSOR SERIAL NUMBER

The compressor serial number is located on the

## INSPECTION AND PERIODIC SERVICE

### PRE-DELIVERY INSPECTION

1. Check that engine exhaust is suitably ventilated.
2. Check the belt for proper tension.
3. With controls positioned for operation of the system, operate the unit for five minutes at approximately 2000 rpm. Observe the clutch pulley bolt to see that the compressor is operating at the same speed as the clutch pulley. Any speed variation indicates clutch slippage.
4. Before turning off the engine, check refrigerant charge (see "Refrigerant Quick Check Procedure").
5. Check refrigerant hose connections:

**"O" Ring Connections** - Check torque of fittings as charted later in this section under "Refrigerant Line Connections;" retorque if required. Leak test the complete system.

6. If there is evidence of an oil leak, check the compressor to see that the oil charge is satisfactory.

**NOTE:** A slight amount of oil leakage at the compressor front seal is considered normal.

7. Check the system controls for proper operation.

### 6000 MILE INSPECTION

1. Check unit for any indication of a refrigerant leak.

## EVACUATING AND CHARGING PROCEDURES

### AIR CONDITIONING SYSTEM CAPACITY

The Motor Home automotive air conditioning system has a refrigerant capacity of 3.5 lbs.

2. If there is an indication of an oil leak, check the compressor for proper oil charge.

**NOTE:** A slight amount of oil leakage at the compressor front seal is considered normal.

3. Check refrigerant charge (see "Refrigerant Quick Check Procedure").
4. Tighten the compressor brace and support bolts and check the belt tension.
5. Check refrigerant hose connections as in Step 5 of "Pre-Delivery Inspection."

### PERIODIC SERVICE

1. Inspect condenser regularly to be sure that the fins are not plugged with leaves or other foreign material.

Also check to be sure fins are not folded over blocking air flow. Fins may be straightened.

2. Check evaporator drain tubes regularly for dirt or restrictions.

3. At least once a year, check the system for proper refrigerant charge and the flexible hoses for brittleness, wear or leaks.

4. Every 6000 miles check for low refrigerant level.

5. Check belt tension regularly.

### INSTALLING CHARGING STATION

1. High and low pressure gauge line fittings are provided in the air conditioning system for attaching the Charging Station. The compressor inlet line and

the high pressure fitting is on the compressor outlet line.

2. With the engine stopped, remove the caps from the cored valve gauge fittings.

3. Install Gauge Adapters J-5420 and J-9459 onto the high and low pressure lines of the Charging Station.

4. Be certain all the valves on the Charging Station are closed.

5. Connect the high pressure gauge line to the high pressure fitting on the system.

6. Referring to Figure 24, turn the high pressure control one turn counterclockwise (open). Crack open the low pressure control and allow refrigerant gas to hiss from the low pressure gauge line for three seconds, and then connect the low pressure line to the low pressure fitting on the system.

**WARNING: WHEN REMOVING THE GAUGE LINES FROM THE FITTINGS, BE SURE TO REMOVE THE ADAPTERS FROM THE SYSTEM FITTINGS RATHER THAN THE GAUGE LINES FROM THE ADAPTER.**

7. The system is now ready for purging or performance testing.

## PURGING THE SYSTEM

In replacing any of the air conditioning components, the system must be completely purged or

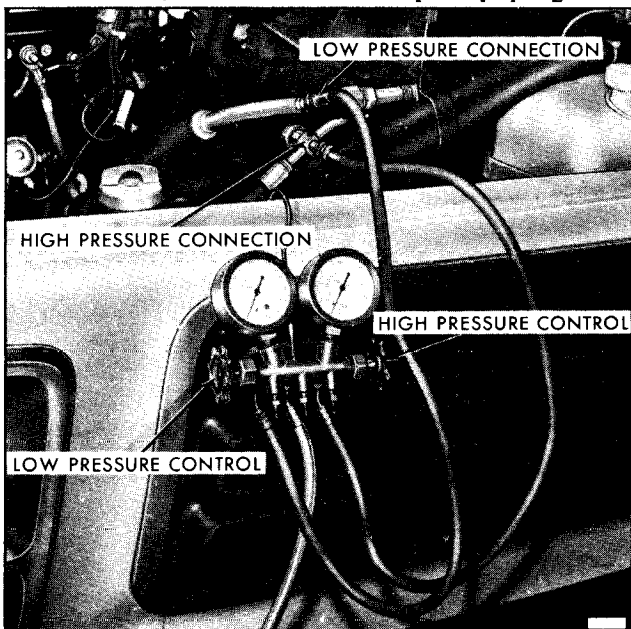

Figure 24—Charging Station Installed

drained of refrigerant. The purpose is to lower the pressure inside the system so that a component part can be safely removed.

1. With the engine stopped, install high and low pressure lines of Charging Station gauge set to the proper high and low pressure gauge fittings (See “Installing The Charging Station”).

**CAUTION:** *Before installing lines, be sure that all four controls on the gauge set are closed.*

2. Disconnect vacuum line at Charging Station vacuum pump and put the line in a covered can.

**NOTE:** An empty 3 lb. coffee can with a plastic cover which has been cross-slit (X’ed), to allow home entry, works well for this purpose.

3. Fully open high (2) and low (1) pressure control valves, and allow refrigerant to purge from system at a rapid rate into the covered can.

4. Oil loss will be minimal. It may be added to the system during evacuation as described later.

5. Toward the end of the purge stage, Tool J-24095 should be flushed with refrigerant to eliminate possible contamination.

a. Disconnect refrigerant line at supply tank.

b. Flush Tool J-24095 by cracking open valve on refrigerant tank. After flushing for approximately three seconds, close valve.

c. Temporarily refasten the tool.

d. Reconnect refrigerant line to supply tank.

## EVACUATING AND CHARGING THE SYSTEM

**NOTE:** In all evacuating procedures shown below, the specification of 28-29 inches of Mercury vacuum is used. These figures are only attainable at or near Sea Level Elevation. For each 1000 feet above sea level where this operation is being performed, the specifications should be lowered by 1 inch. Example: at + 5000 ft. elevation, only 23 to 24 inches of vacuum can normally be obtained.

Whenever the air conditioning system is open for any reason, it should not be put into operation again



until it has been evacuated to remove air and moisture which may have entered the system.

The following procedures are based on the use of the J-24410 Charging Station:

## ADDING OIL

If necessary, refrigeration oil may be added to the system by the following method:

1. Install charging station and purge system as previously described.
2. After system has been purged, connect the vacuum line to the vacuum pump.
3. Measure oil loss collected as a result of purging the system.
  - a. Disconnect the Charging Station low pressure line. Install Tool J-24095 (with valve closed) onto the system low pressure fitting. Insert pickup tube into graduated container of clean refrigerant oil (figure 25).

**NOTE:** Tool J-24095 will hold 1/2 of an ounce of oil in the tool itself. So if 1 oz. has to be added, the level of the oil in the bottle should decrease 1-1/2 ounces to add 1 oz. to the system.

**CAUTION:** *When removing the gauge lines from the fittings, be sure to remove the adapters from the system fittings rather than the gauge lines from the adapter.*

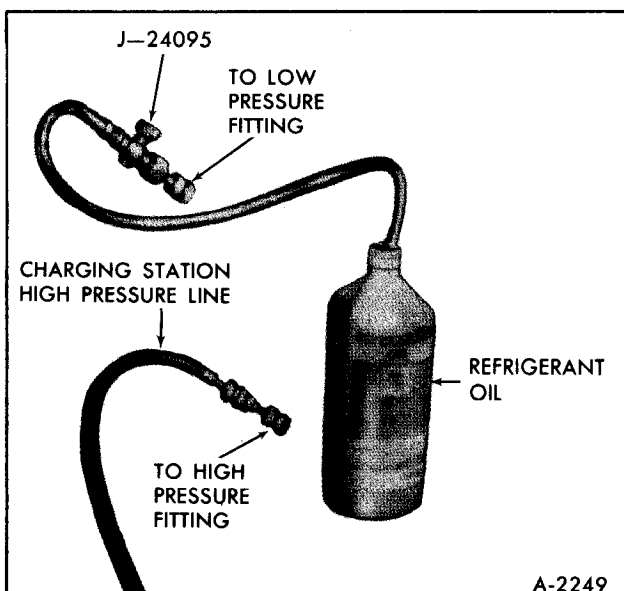

Figure 25—Adding Refrigeration Oil

b. Turn on vacuum pump, and open vacuum control valve (slowly open high pressure side of manifold gauge set to avoid forcing oil out of refrigerant system and pump).

**NOTE:** When valve on Tool J-24095 is opened, the vacuum applied to the discharge side of the system will suck oil into system from container. Therefore, close observation of oil level in the container is necessary.

c. Note level of oil in container. Open valve on oil adding tool until oil level in container is reduced by an amount equal to that lost during discharge of system plus 1/2 ounce, then close valve. **Take care not to add more oil than was lost.**

d. Disconnect and cap Tool J-24095 and reinstall charging station low pressure line to the system. Open low pressure valve.

## EVACUATION

After oil has been added to the system (as outlined above), run pump until 28-29 inches vacuum is obtained (See Note under "Evacuating and Charging the System"). Continue to run pump for 10 minutes after the system reaches 28-29 inches vacuum.

**NOTE:** If 28-29 inches cannot be obtained, close Vacuum Control Valve and shut off vacuum pump. Open Refrigerant Control Valve and allow 1/2 pound of R-12 to enter system. Locate and repair all leaks. Purge this 1/2 pound and re-evacuate for 10 minutes.

1. During the ten minute evacuation period, prepare for charging the system by filling the charging cylinder as follows:

a. Open valve on bottom of charging cylinder allowing refrigerant to enter cylinder.

**NOTE:** It will be necessary to close bleed valve periodically to allow boiling to subside to check level in the sight glass of Charging Station cylinder.

b. Bleed cylinder valve on top (behind control panel) as required to allow refrigerant to enter. When refrigerant reaches desired level (see "System Capacity"), close valve at bottom of cylinder and be certain bleed valve is closed securely.

2. Continue to evacuate for remainder of 10 minute period.

3. Turn hand shut-off valves at low and high pressure gauges of gauge set to full clockwise position with vacuum pump operating, then stop pump. Carefully check low pressure gauge for approximately two minutes to see that vacuum remains constant. If vacuum reduces, it indicates a leak in the system or gauge connections; locate and repair all leaks.

## CHARGING THE SYSTEM

1. Only after evacuating as above, is system ready for charging. Note reading on sight glass of charging cylinder. If it does not contain a sufficient amount of refrigerant for a full charge, fill to the proper level.

2. With High and Low Pressure Valves open, close Vacuum Control Valve, turn off vacuum pump, open refrigerant control valve and allow refrigerant to enter system.

**NOTE:** If the charge will not transfer completely from the station to the system, close the high pressure valve at the gauge set, set the air conditioning controls for cooling, check that the engine compartment is clear of obstructions, and start the engine. Compressor operation will decrease the low side pressure in the system.

System is now charged and should be checked as outlined below:

## CHECKING SYSTEM OPERATION

1. Operate system for a maximum of five minutes at maximum cooling, high blower speed and with engine operating at 2000 RPM (exhaust should be vented if inside).

2. When system is stabilized, the pressure gauges on the charging station should read pressures corresponding to values listed under **PERFORMANCE DATA**.

3. When correct system pressures are observed, check system charge as described under "Refrigerant Quick Check Procedure".

4. Feel outlet air distribution to ensure that cold air is being distributed.

5. Disconnect gauge lines and cap fittings.

**CAUTION:** *When removing gauge lines from fittings, be sure to remove the adapters from*

*the fittings rather than the gauge lines from the adapters.*

## PERFORMANCE TEST

Under normal circumstances, it will not be necessary to Performance Test a system as outlined below; however, in certain instances, the following procedure may be advantageous in diagnosing system malfunction.

The following fixed conditions must be adhered to in order to make it possible to compare the performance of the system being tested with the standards below:

1. Doors and windows closed. (Vehicle inside or in shade.) Close driver's compartment curtains.

2. Vehicle in NEUTRAL with engine running at 2000 rpm.

3. Air Conditioning controls set for -

- Maximum cooling.
- High blower speed.

5. TEMP control set at "RECIRC" and all air conditioning outlets open.

6. Gauge set installed.

7. System settled out (run-in approximately 10 minutes).

8. A thermometer placed in front of vehicle grille and another in the center diffuser outlet.

9. An 18" fan placed in front of the vehicle and blowing into the condenser.

**NOTE:** Higher temperatures and pressures will occur at higher ambient temperatures. In areas of high humidity it is possible to have thermometer and gauge readings approach but not reach the figures listed in the performance table and still have a satisfactory operating unit. However, it is important to remember that low pressure has a direct relationship to nozzle outlet temperature. If pressure is too low, ice will gradually form on the evaporator fins, restricting air flow into the passenger area and resulting in insufficient or no cooling.

## PERFORMANCE DATA

The following Performance Data define normal operation of the system under the above conditions.

Relative humidity does not appear in the tables because after running the prescribed length of time on recirculated air and maximum cooling, the relative humidity of the air passing over the evaporator core will remain at approximately 35% to 40% regardless of the ambient temperature or humidity.

(Refrigerant Charge – 3.5 lbs.)						
Temperature of Air Entering Condenser	70°	80°	90°	100°	110°	120°
Engine rpm	2000 RPM					
Compressor Head Pressure*	130 - 145	150 - 165	160 - 175	180 - 195	205 - 220	240 - 255
Suction Pressure*	8 - 10	8 - 10	8 - 10	8 - 10	11 - 14	12 - 15
Discharge Air Temp. at Right Upper Outlet*	41 - 44	41 - 44	42 - 45	45 - 48	50 - 53	55 - 58

\*Just prior to compressor clutch disengagement

### CHECKING OIL

In the six cylinder compressor it is not recommended that the oil be checked as a matter of course. Generally, compressor oil level should be checked only where there is evidence of a major loss of system oil such as might be caused by:

- A broken refrigerant hose
- A severe hose fitting leak
- A very badly leaking compressor seal
- Collision damage to the system components

As a quick check on compressor oil charge, operate the engine at *idle* on maximum cold for approximately 10 minutes, turn off the engine and momentarily crack open the oil drain plug on bottom of the compressor letting a slight amount of oil drain out. Retighten plug. Again slightly crack open the plug. If oil comes out, the compressor has the required amount of oil.

Evaporator Core .....	3 fluid oz.
Condenser.....	1 fluid oz.
Receiver-Dehydrator .....	1 fluid oz.

**CAUTION:** When adding oil to the compressor, it will be necessary to tilt the rear end of the compressor up so that the oil will not

**NOTE:** The oil may appear foamy. This is considered normal.

To further check the compressor oil charge, should the above test show insufficient oil, it is necessary to remove the compressor from the vehicle, drain and measure the oil as outlined under "Checking Compressor Oil Charge."

### CHECKING COMPRESSOR OIL CHARGE

1. Run the system for 10 minutes at 600 engine rpm with controls set for maximum cooling and high blower speed.

2. Turn off engine, discharge the system, remove compressor from vehicle, place it in a horizontal position with the drain plug downward. Remove the drain plug and, tipping the compressor back and forth and rotating the compressor shaft, drain the oil into a clean container, measure and discard the oil.

3. Add new refrigeration oil to the compressor as follows.

a. If the quantity drained was 4 fluid oz. or more, add the same amount of new refrigeration oil to the replacement compressor.

b. If the quantity drained was less than 4 fluid oz., add 6 fluid oz. of new refrigeration oil to the replacement compressor.

c. If a new service compressor is being installed, drain all oil from it and replace only the amount specified in Steps 3a and 3b above.

d. If a field repaired compressor is being installed, add an additional 1 fluid oz. to the compressor.

e. If the oil contains chips or other foreign material, flush or replace all component parts as necessary. Add the full 10 fluid oz. of new refrigeration oil to the replacement compressor.

4. Add additional oil in the following amounts for any system components being replaced.

*run out of the suction and discharge ports. Do not set the compressor on the shaft end.*

## REFRIGERANT QUICK-CHECK PROCEDURE

The following procedure can be used to quickly determine whether or not an air conditioning system has a proper charge of refrigerant. This check can be made in a manner of minutes thus facilitating system diagnosis by pinpointing the problem to the amount of charge in the system or by eliminating this possibility from the overall checkout.

Start engine and place on fast idle. Set controls for maximum cold with blower on high.

<p>Bubbles present in sight glass. System low on charge. Check with leak detector. Correct leak, if any, and fill system to proper charge.</p>	<p>No bubbles. Sight glass clear. System is either fully charged or empty. Feel high and low pressure pipes at compressor. High pressure pipe should be warm; low pressure pipe should be cold.</p>
<p>No appreciable temperature differential noted at compressor. System empty or nearly empty. Turn off engine and connect Charging Station. Induce 1/2# of refrigerant in system (if system will not accept charge, start engine and draw 1/2# in through low pressure side). Check system with leak detector.</p>	<p>Temperature differential noted at compressor. Even though a differential is noted, there exists a possibility of overcharge. An overfilled system will result in poor cooling during low speed operation (as a result of excessive head pressure), An overfill is easily checked by disconnecting the compressor clutch connector while observing the sight glass.</p>
<p>If refrigerant in sight glass remains clear for more than 45 seconds (before foaming and then setting away from sight glass) an overcharge is indicated. Verify with a performance check.</p>	<p>If refrigerant foams and then settles away from sight glass in less than 45 seconds, it can be assumed that there is a proper charge of refrigerant in system. Continue checking out system using performance checks outlined previously.</p>

## MAINTENANCE AND ADJUSTMENTS

### THERMOSTATIC SWITCH

The system makes use of a thermostatic switch with an air sensing capillary. This capillary controls the switch by sensing the temperature of the air leaving the fins.

### CHECKING FOR PROPER OPERATION

1. Install the gauge set and set up the vehicle as described under "Performance Test".

2. Set the control at A/C, HI blower, max COLD and run the engine at 2000 rpm.

a. The thermostatic switch should cycle the compressor off when the low limit of the outlet air temperature is reached (see Performance Data). If it does not, the switch points are fused which will lead to evaporator freeze up. Replace the switch.

b. If the compressor does not operate, a loss of power element charge is indicated (provided that it has been established that power is supplied to the switch). This, of course, results in no cooling. Replace the switch.

c. Check the switch adjusting screw for stripped or otherwise damaged threads.

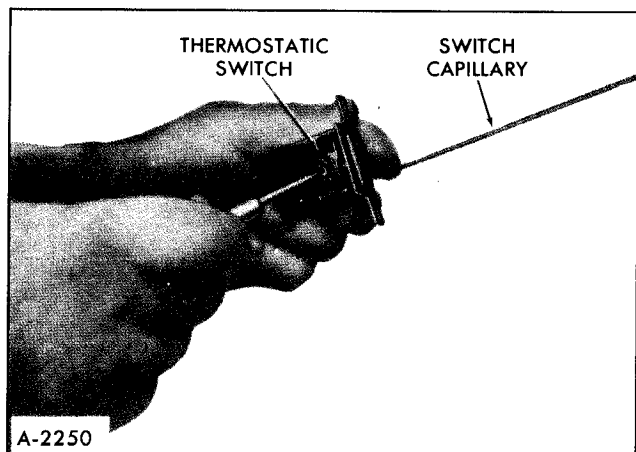

Figure 26—Adjusting Thermostatic Switch

## ADJUSTING SWITCH

If, after the above checks, the switch seems to be operating properly, adjust for proper setting if necessary, as follows:

1. Vehicle must be set up as described in "Performance Test."

2. The suction side of the system, read on the low pressure gauge, should pull down to the pressure shown in the chart in "Performance Data" under the ambient temperature at the time the switch is being set.

3. Remove the switch as outlined in the "General Repair Procedures" section.

4. Remove the switch non-metal end plate to gain access to the switch adjusting screw.

5. If the outlet temperature was less than the prescribed temperature at the end of each cooling cycle, turn the adjusting screw a partial turn counter-clockwise (figure 26). If the outlet temperature was more than prescribed temperature, turn the adjusting screw clockwise.

**NOTE:** One turn of the adjusting screw will change the outlet temperature approximately 4 degrees.

6. Reinstall switch end plate and reinstall switch. Be sure that the air sensing capillary has been replaced properly.

7. Check system performance. If further adjustment is needed, repeat Steps 3 through 6 until the prescribed pressure is reached.

**NOTE:** Do not attempt to run a Performance Check with the system disassembled since inac-

curate readings would be the result. ALWAYS reinstall switch and capillary and any duct work before running a performance check.

## EXPANSION VALVE (FIGURE 14)

A malfunction of the expansion valve will be caused by one of the following conditions; valve stuck open, valve stuck closed, broken power element, a restricted screen or an improperly located or installed power element bulb.

Attachment of the expansion valve bulb to the evaporator outlet pipe is very critical. The bulb must be attached tightly to the pipe and must make good contact with the pipe along the entire length of the bulb. A loose bulb will result in high "high side" pressures and poor cooling. On bulbs located outside the evaporator case, insulation must be properly installed.

Indications of expansion valve trouble provided by the Performance Test are as follows:

### VALVE STUCK OPEN

Noisy Compressor.

No Cooling - Freeze Up.

### VALVE STUCK CLOSED, PLUGGED SCREEN OR BROKEN POWER ELEMENT

Very Low Suction Pressure.

No Cooling.

### POORLY LOCATED POWER ELEMENT BULB

Normal Pressure.

Poor Cooling.

## CHECK FOR DEFECTIVE VALVE

The following procedure must be followed to determine if a malfunction is due to a defective expansion valve.

1. Check to determine if the system will meet the performance test as outlined previously. If the expansion valve is defective, the low pressure readings will be above specification.

2. The loss of system performance is not as evident when the high side pressure is below 200 PSI. Therefore, it may be necessary to increase the system high side pressure by partially blocking the condenser. Disconnect the blower lead wire and repeat the "Performance Check" to determine if the low side pressure can be obtained.

# GENERAL REPAIR PROCEDURES AND COMPONENT REPLACEMENT

## PREPARING SYSTEM FOR REPLACEMENT OF COMPONENT PARTS

Air conditioning, like many other things, is fairly simple to service once it is understood. However, there are certain procedures, practices and precautions that should be followed. For this reason it is strongly recommended that the preceding information in this section be studied thoroughly before attempting to service the system.

Great emphasis must be placed upon keeping the system clean. Use plugs or caps to close system components and hoses when they are opened to the atmosphere. Keep your work area clean.

In removing and replacing any part which requires unsealing the refrigerant circuit the following operations, which are described in this section, must be performed in the sequence shown.

1. Purge the system by releasing the refrigerant to the atmosphere.
2. Remove and replace the defective part.
3. Evacuate, charge and check the system.

**WARNING: ALWAYS WEAR PROTECTIVE GOGGLES WHEN WORKING ON REFRIGERATION SYSTEMS. GOGGLES J-5453 ARE INCLUDED IN THE SET OF AIR CONDITIONING SPECIAL TOOLS. ALSO, BEWARE OF THE DANGER OF CARBON MONOXIDE FUMES BY AVOIDING RUNNING THE ENGINE IN CLOSED OR IMPROPERLY VENTILATED GARAGES.**

## FOREIGN MATERIAL IN THE SYSTEM

Whenever foreign material is found in the system, it must be removed before restoring the system to operation.

In the case of compressor mechanical failure, perform the following operations:

1. Remove the compressor.

2. Remove the receiver-dehydrator or expansion tube and discard the unit.

3. Flush the condenser to remove foreign material which has been pumped into it.

4. Disconnect the line at the evaporator core inlet or inlet line to the expansion valve.

Inspect the expansion tube or inlet screen of the expansion valve for the presence of metal chips or other foreign material. If the tube or screen is plugged, replace it. Reconnect the line to the evaporator core or expansion valve.

5. Install the replacement compressor.

6. Add the necessary quantity of oil to the system. Remember to add the one ounce for the new receiver-dehydrator.

7. Evacuate, charge and check system.

## REFRIGERANT LINE CONNECTIONS

### "O" RINGS

Always replace the "O" ring when a connection has been broken. When replacing the "O" ring, first dip it in clean refrigeration oil. Always use a backing wrench on "O" ring fittings to prevent the pipe from twisting and damaging the "O" ring. Do not over-tighten. Correct torque specifications are as follows:

**CAUTION:** *Where steel to aluminum connections are being made, use torque for aluminum tubing.*

Metal Tube O.D.	Thread and Fitting Size	Steel Tubing Torque*	Alum. Tubing Torque*
1/4	7/16	13	6
3/8	5/8	33	12

Metal Tube O.D.	Thread and Fitting Size	Steel Tubing Torque*	Alum. Tubing Torque*
1/2	3/4	33	12
5/8	7/8	33	20
3/4	1-1/16	33	25

\* Foot Pounds

### HOSE CLAMPS

When hose clamp connections are encountered, special procedures are necessary for both removal and installation.

#### Removal

1. Carefully, with a sharp knife, make an angle cut in the hose as shown in Figure 27. This should loosen the hose so that it may be worked off the fitting.

2. Cut off slit end of hose.

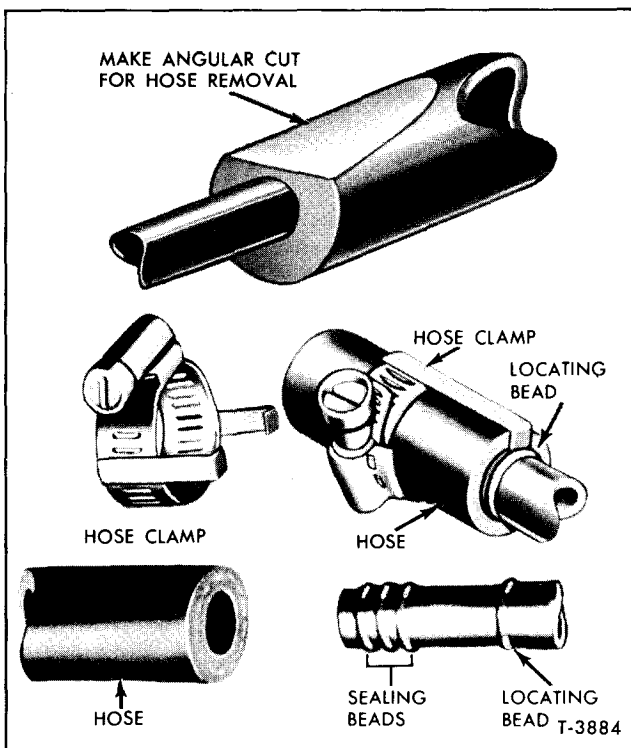

Figure 27-Hose Clamp Connections

**CAUTION:** Use only approved refrigeration hose. Never use heater hose. Use extreme care not to nick or score the sealing beads when cutting off the hose. Cutting the hose lengthwise may result in this problem.

#### Installation

1. Coat tube and hose with clean refrigeration oil.

2. Carefully insert hose over the three beads on the fitting and down as far as the fourth, or locating bead. Hose must butt against this fourth bead.

**CAUTION:** Use no sealer of any kind.

3. Install clamps on hose, hooking the locating arms over the cut end of the hose.

4. Tighten the hose clamp screw to 35-42 in. lbs. torque. **DO NOT RETORQUE.** The clamp screw torque will normally decrease as the hose conforms to the force of the clamp. The screw should be retorqued only if its torque falls below 10 in. lbs. In this case, retorque to 20-25 in. lbs. Further tightening may damage the hose.

### REPAIR OF REFRIGERANT LEAKS

Any refrigerant leaks found in the system should be repaired in the manner given below:

#### LEAKS AT "O" RING CONNECTION

1. Check the torque on the fitting and, if too loose, tighten to the proper torque. Always use a backing wrench to prevent twisting and damage to the "O" ring. Do not overtighten. Again leak test the joint.

2. If the leak is still present, discharge the refrigerant from the system as described under "Evacuating and Charging Procedures."

3. Inspect the "O" ring and the fitting and replace if damaged in any way. Coat the new "O" ring with clean refrigeration oil and install carefully.

4. Retorque the fitting, using a backing wrench.

5. Evacuate, charge and check the system.

#### LEAKS AT HOSE CLAMP CONNECTION

1. Check the tightness of the clamp itself and tighten if necessary. Recheck for leak.

2. If leak has not been corrected, discharge the system and loosen clamp and remove hose from connection. Inspect condition of hose and connector. Replace scored or damaged parts.

3. Dip end of new hose in clean refrigeration oil and carefully reinstall over connector. Never push end of hose beyond the locating bead. Properly torque the clamp.

4. Evacuate, charge and check the system.

## COMPRESSOR LEAKS

If leaks are located around the compressor shaft seal or shell, replacement of necessary seals should be made.

**NOTE:** A slight amount of oil leakage past the compressor front seal is considered normal.

## REFRIGERANT HOSE FAILURE

After a leak or rupture has occurred in a refrigerant hose, or if a fitting has loosened and caused a considerable loss of refrigerant and oil, the entire system should be flushed and recharged after repairs have been made.

Because of the length of the hoses on these systems, hose leaks may be repaired using the following procedure:

1. Locate the leak.
2. Discharge the system.

3. Cut out the leaking portion of the hose, making sure that all of the failed portion is removed. If only a very small portion of the hose was removed, it may be possible to splice the two ends together, using a special hose connector and two hose clamps. If several inches of hose must be removed, a new piece of hose should be spliced in using two connectors and four hose clamps. Dip the ends of the hoses in clean refrigeration oil before installing the hoses onto the connector. Never push the end of the hose beyond the locating bead of the connector. Torque the clamp to 35-42 in. lbs.

**NOTE:** Be sure to replace the hose in the body in the same manner as when removed. If the hose protective grommets are badly mutilated, they should be replaced.

4. Evacuate, charge and check the system.

## COMPRESSOR

### REMOVAL

1. Purge the refrigerant from the system.
2. Remove engine cover to gain access to engine components
3. Remove connector attaching bolt and hose connector (figure 28). Seal connector outlets.
4. Disconnect electrical lead to clutch actuating coil (figure 28).
5. Disconnect the hose holding clamp at the clutch pulley shield.
6. Loosen brace and pivot bolts and detach belt.
7. Remove the nuts and bolts attaching the compressor brackets to the mounting bracket.
8. Remove compressor and attaching brackets and shield by sliding rearward and dropping out bottom. Be sure compressor is removed with attaching brackets as shown in Figure 29.
9. Before beginning any compressor disassembly, drain and measure oil in the compressor. Check for evidence of contamination to determine if remainder of system requires servicing.

### INSTALLATION

1. If oil previously drained from the compressor upon removal shows no evidence of contamination, replace a like amount of fresh refrigeration oil into

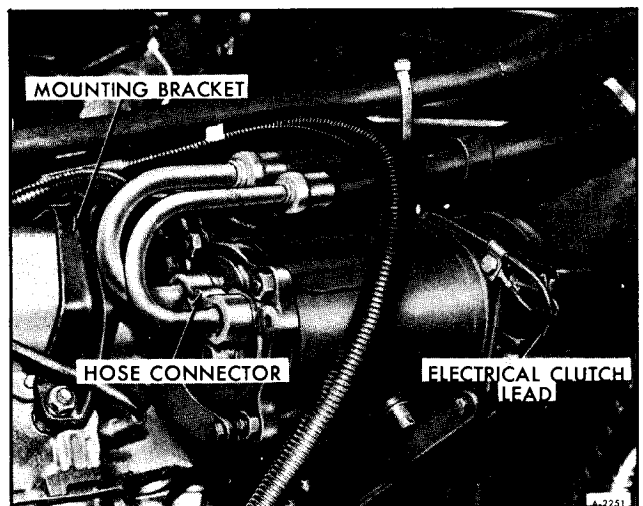

Figure 28-Compressor Installation



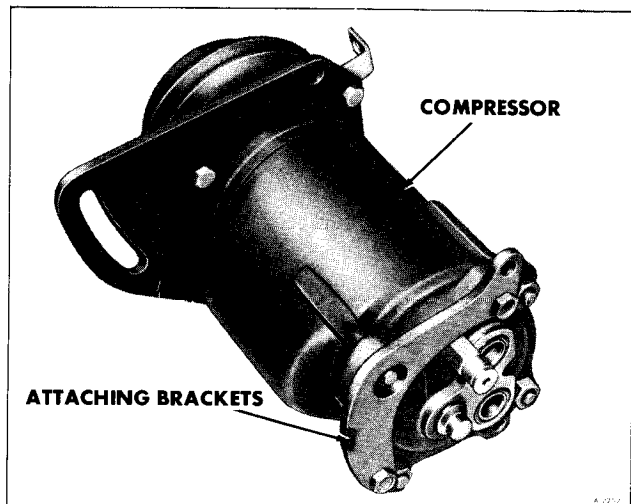

Figure 29 –Compressor Removed From Vehicle

the compressor before reinstallation. If it was necessary to service the entire system because of excessive contamination in the oil removed, install a full charge of fresh refrigeration oil into the compressor.

2. Position compressor on the mounting bracket and install all nuts, bolts and lock washers.
3. Install the connector assembly to the compressor rear head, using new "O" rings coated with clean refrigeration oil.
4. Connect the electrical lead to the coil and install and adjust compressor belt.
5. Evacuate, charge and check the system.

**IMPORTANT:** Adjust compressor belt, using belt tension gauge J-23600 or other suitable gauge. Tension should be within 70-80 lbs. (used belt), or 110-140 lbs. (new belt).

## COMPRESSOR FAILURE

If the compressor has failed mechanically to the extent that metal chips and shavings are found in it, the system should be checked for foreign material and cleaned as described under Foreign Material in the System.

## FALSE COMPRESSOR SEIZURE

Slipping or broken air conditioning drive belts and/or scored clutch surfaces may be experienced on initial start up of an air conditioning compressor after an extended period of storage or non-operation

of the compressor. This would indicate a seized compressor; however, an overhaul or replacement of the compressor may not be necessary.

During extended periods of non-operation, changes in temperature cause the refrigerant in the air conditioning compressor to expand and contract. During this movement, lubricating oil carried by the refrigerant tends to migrate from highly polished surfaces in the compressor such as the ball seats and wobble plate. Without lubricating oil at these polished surfaces, they "wring" together and appear to be seized.

Before the time and expense of an overhaul is invested, use the following check to determine if the compressor is actually seized. With a wrench on the compressor shaft lock nut or Spanner Wrench J-9403 on the clutch drive plate, "rock" the shaft in the opposite direction of normal rotation. After the compressor is broken loose, "rock" the shaft back and forth. This should be sufficient to return lubricating oil to the "wring" surfaces and allow the compressor shaft to be turned by hand. Once the compressor turns freely, rotate the compressor at least three complete turns. Start the engine and operate the compressor for a minimum of one minute.

This procedure will not affect a compressor that is actually seized but should be attempted before overhauling a compressor known to be idle for a month or longer.

## COLLISION PROCEDURE-ALL SYSTEMS

Whenever a vehicle equipped with an air conditioning unit is involved in a collision or wreck, it should be inspected as soon as possible. The extent or damage to any of all of the component parts and the length of time the system has been exposed to the atmosphere will determine the replacement of parts and processing that will be required. The greater the length of time of exposure to the atmosphere, the greater will have been the chances for air, moisture and dirt to have entered and damaged the system. Every case may be entirely different so it is not possible to establish a hard and fast procedure to follow each time. Good judgment must be used to determine what steps should be taken in each specific case.

The following procedure is presented as a guide for use when inspecting a damaged vehicle equipped with air conditioning.

1. Remove the drive belt.
2. Visually inspect the condenser, receiver-dehydrator, compressor, mounting brackets, conditioning

unit, all connecting lines and all controls to determine the extent and nature of the damage.

a. No repairs, such as soldering, welding or brazing, should be attempted on the condenser because of its construction. If the vapor passages in the horizontal tubes or return bends or manifolds have been damaged in any way, the condenser should be replaced with a new one.

b. The receiver-dehydrator should be replaced if there is any evidence of its having sustained either internal damage or a fracture at any of the lines or welded joints or if the system has been exposed to the atmosphere for an undetermined period of time.

c. Examine the compressor for any visible external damage.

d. The evaporator should be examined for damage and, if necessary, removed or replaced or the entire unit processed where damaged or exposed to the atmosphere.

e. All connecting lines and flexible hoses should be examined throughout their entire length for damage. If damaged in any manner, replace with new lines.

f. Check all controls and connecting wires for damage and replace with new parts where needed.

g. Check the clutch pulley for proper operation and freedom from damage.

3. Install Charging Station.

4. Purge the system.

5. Remove the compressor from mounting and remove the oil test fitting.

6. Pour out the oil into a clean glass container and examine it for any foreign substance such as dirt, water, metal particles, etc. If any of these are present, the compressor, expansion tube, and receiver-dehydrator should be replaced and the other system components should be flushed with liquid refrigerant.

7. If the oil is clean and free of any harmful substance, replace oil with Frigidaire 525 Viscosity Oil, or equivalent.

**NOTE:** If the system components have been replaced or flushed, replace the full charge of oil. If not, add no more fresh oil than was drained in Step 6.

8. Charge up the compressor to cylinder or can pressure. Leak test the compressor seals prior to installation of compressor.

9. Reinstall the compressor and evacuate the system by following the Evacuating Procedure.

10. Introduce R-12 vapor at cylinder (room) temperature and pressure.

11. Leak test all fittings and connections and give particular attention to a leak test at the compressor shaft seal if compressor has not been leak tested on the bench.

12. Complete system processing and charge system.

## CONDENSER

### REPLACEMENT

1. Disconnect battery ground cables.

2. Purge the system of refrigerant.

3. Remove grill assembly.

4. Disconnect the condenser inlet and outlet lines. Cap or plug all open connections at once.

5. Remove the receiver-dehydrator and its holding straps (See figure 13).

6. Remove the condenser to radiator mounting screws (figure 30).

7. Remove the condenser assembly by pulling it forward and then lowering it from the vehicle through grille.

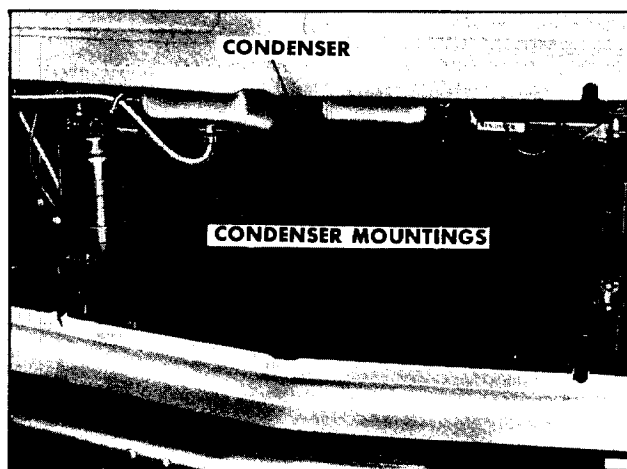

Figure 30—Condenser Mounting

8. To install a new condenser, reverse Steps 1-6 above. Add one fluid ounce of clean refrigeration oil to a new condenser.

**NOTE:** Use new "O" rings, coated with clean refrigeration oil, when connecting all refrigerant lines.

9. Evacuate, charge and check the system.

## RECEIVER-DEHYDRATOR

### REPLACEMENT

1. Disconnect the inlet and outlet lines being sure to use a wrench on the square portion of the receiver dehydrator for support. This will prevent twisting and possible breaking of the aluminum lines (See figure 31).

2. Loosen holding straps and slide out receiver-dehydrator.

3. To install, reverse steps 1 and 2 being sure to add 1 ounce of clean refrigeration oil and install new "O" rings.

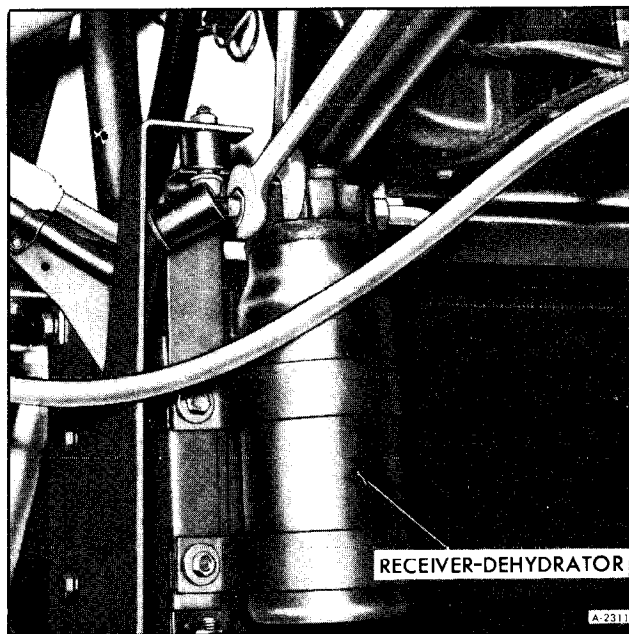

Figure 31-Disconnecting Lines to Receiver-Dehydrator

## BLOWER ASSEMBLY (FIGURE 32)

### REPLACEMENT

1. Disconnect the battery ground cables.

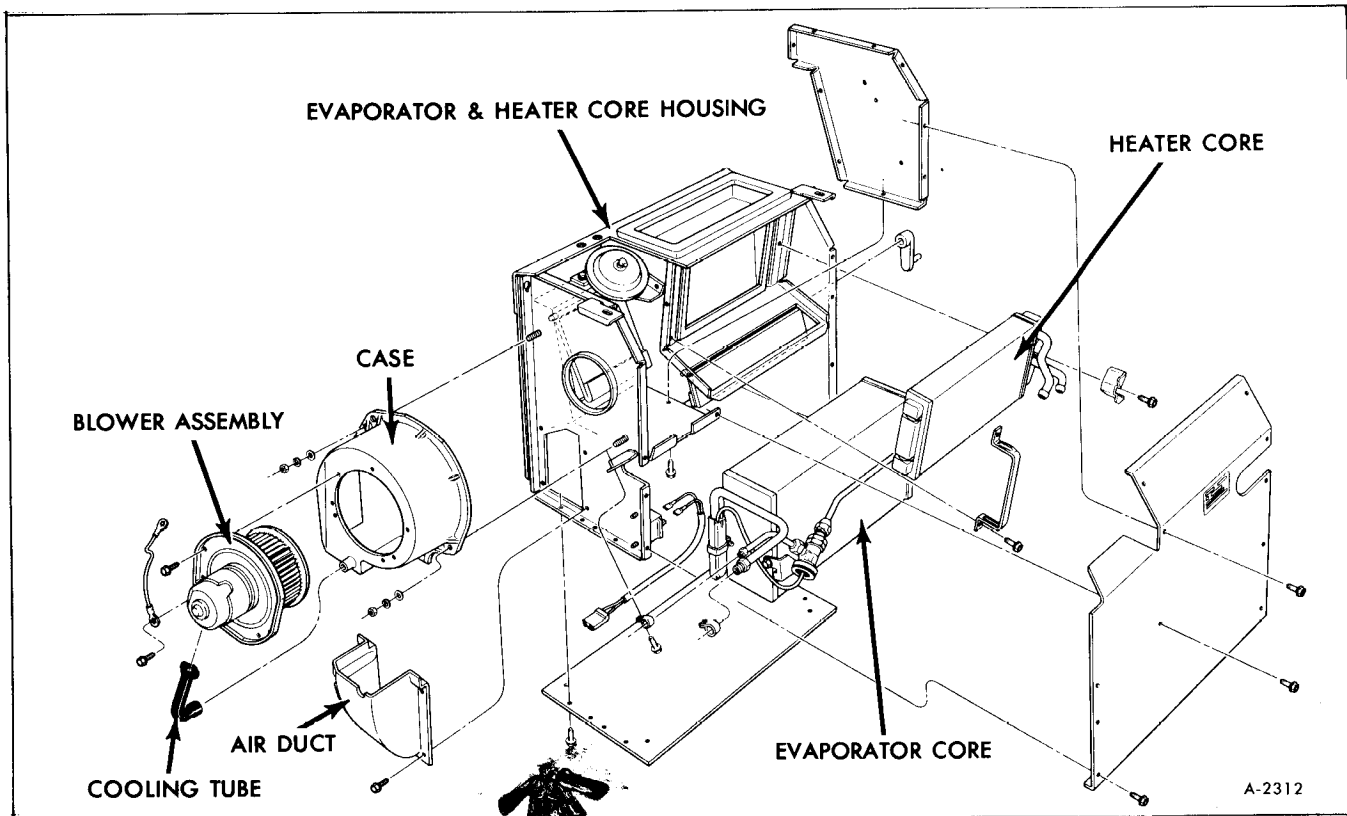

Figure 32-Evaporator and Heater Housing Components

2. Disconnect the blower motor lead and ground wires.
3. Disconnect the blower motor cooling tube.
4. Remove the blower to case attaching screws and remove the blower assembly. Pry the blower flange away from the case carefully if the sealer acts as an adhesive.
5. Remove the nut attaching the blower wheel to the motor shaft and separate the assemblies.
6. To install, reverse Steps 1-5 above; replace sealer as necessary.

## EVAPORATOR AND HEATER CORE ASSEMBLY

### REPLACEMENT (FIGURE 14)

1. Purge system.
2. Disconnect air conditioning lines from evaporator.
3. Disconnect heater hoses from heater core.
4. Disconnect all vacuum lines, wires and cables connected to the box assembly.
5. Remove windshield washer reservoir.
6. Remove coolant recovery reservoir and bracket.
7. Disconnect windshield wiper arms.
8. Remove attaching bolts and remove through front access door.
9. To install, reverse steps 1 through 8.

## EVAPORATOR CORE AND EXPANSION VALVE

### REPLACEMENT (FIGURE 14)

**CAUTION:** *When repair or replacement of the evaporator core or expansion valve is necessary, be sure to remove both as the method of attaching the sensing tube to the evaporator outlet line will cause it to be damaged if you try to remove only one item.*

1. Purge the system of refrigerant.
  2. Remove all attaching items to the evaporator and heater core assembly necessary to remove the assembly front cover.
  3. Remove assembly front cover exposing evaporator core, expansion valve, thermostat switch, heater core and selector door.
- NOTE:** After removing all the cover screws, be sure to remove the cover retaining clip.
4. Remove evaporator inlet and outlet hoses.
  5. Carefully remove thermostatic switch probe from front of evaporator held by plastic clips. Do not bend this tube excessively.
  6. Remove four attaching screws and gently pull out evaporator core.
  7. When core and expansion valve are removed the expansion valve may easily be removed without damaging the sensing tube.
  8. To install, reverse steps 1-7.

## VACUUM TANK

The vacuum tank is mounted to the right side of the evaporator and heater core assembly (See figure 14).

### REPLACEMENT

1. Disconnect the vacuum lines at the tank.
2. Remove the tank to dash panel screws and remove the tank.
3. To install, reverse Steps 1 and 2 above.

## BLOWER MOTOR RESISTOR

The blower motor resistor is located opposite the blower side of the blower-evaporator case (figure 14).

### REPLACEMENT

1. Disconnect battery ground cables and the wiring harness at the resistor.

2. Remove the resistor to case attaching screws and remove the resistor.

3. Place the new resistor in position and install the attaching screws.

4. Connect the resistor wiring harness and battery cables.

## THERMOSTATIC SWITCH (FIGURE 14)

The thermostatic switch is mounted to the blower side of the blower-evaporator case. The switch sensing capillary extends across the evaporator core.

### REPLACEMENT

1. Disconnect the battery ground cables.

2. Disconnect the wiring harness at the switch.

3. Remove the switch to case screws and remove the switch carefully so as not to damage the capillary tube.

**NOTE:** Note capillary tube position across the core so that the capillary may be reinstalled in the same position.

4. Place the new switch in position, installing the capillary in the core in the same manner as at switch removal.

5. Install the switch mounting screws, connect the wiring harness and the battery ground cables.

## DISCHARGE PRESSURE SWITCH

The discharge pressure switch is located in the condenser to evaporator line (figure 16).

### REPLACEMENT

1. Disconnect the battery ground cables.

2. Purge the system of refrigerant.

3. Disconnect the wiring harness at the switch.

4. Remove the switch from the refrigerant line.

5. To install, reverse Steps 1-4 above.

**NOTE:** Be sure to use new "O" rings, coated with clean refrigeration oil, when installing the switch.

6. Evacuate charge and check system operation.

## FUSE

A 25 amp fuse, located in the junction block protects the entire air conditioning system except for the blower when operating at HI.

## BLOWER MOTOR RELAY

The blower motor relay is located on the firewall on the blower side of the blower-evaporator case (figure 18).

### REPLACEMENT

1. Disconnect battery ground cables and the wiring harness at the relay.

2. Remove the relay to case attaching screws and remove the relay.

3. Place the new relay in position and drive the mounting screws.

4. Connect the relay wiring harness and battery ground cables.

## CONTROL ASSEMBLY (FIGURE 21)

### REPLACEMENT

1. Disconnect the battery ground cables.

2. Remove instrument panel bezel.

**NOTE:** For details on instrument panel bezel removal refer to "Instrument Panel Bezel Replacement" contained in CHASSIS ELECTRICAL (SECTION 12) of this manual.

3. Remove four screws holding control assembly to instrument panel (figure 33).

4. Pull panel forward to gain access to rear of control assembly.

**CAUTION:** *Be careful not to kink the bowden cable.*

5. Disconnect the bowden cable, vacuum harness and electrical harness at the control.

6. If a new unit is being installed, transfer all electrical switches and vacuum valves to the new control.

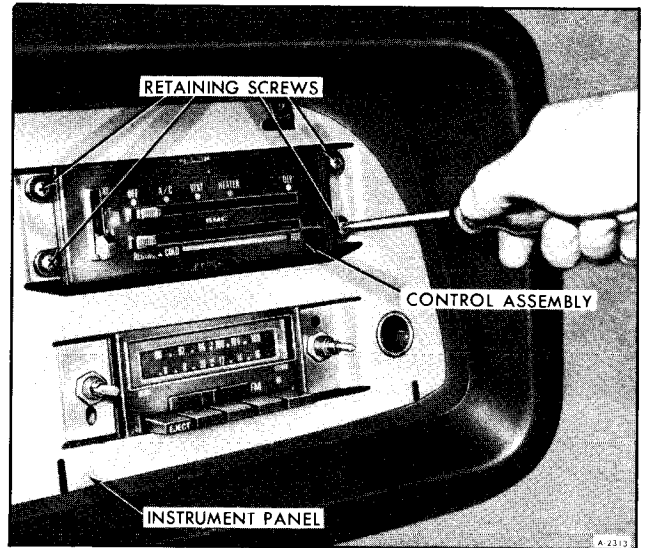

Figure 33—Removing Control Assembly

3. Installation of switch is the reverse of Steps 1 and 2.

## BLOWER SWITCH (FIGURE 20)

### REPLACEMENT

1. Remove the control assembly as described above.

2. Disconnect wires to switch and remove two attaching screws.

# COMPRESSOR MINOR OVERHAUL PROCEDURES

The following operations to the hub and drive plate, pulley and bearing, and coil housing are covered as "Minor" because they may be performed without first purging the system or removing the compressor from the vehicle. The shaft seal assembly may also be serviced without removing the compressor from the vehicle, but this operation is covered later in this Manual as a "Compressor Major Overhaul Procedure" because the system must first be purged of refrigerant.

Illustrations used in describing these operations show the compressor removed from the vehicle to more clearly illustrate the various operations.

## HUB AND DRIVE PLATE

### REMOVAL

1. If disassembly is being performed on a bench, mount support bracket (J-9396) in a vise and attach the compressor to the bracket.

2. Using drive plate holding tool (J-9403) and socket J-9399, remove the lock nut from the shaft (figure 34). Discard lock nut.

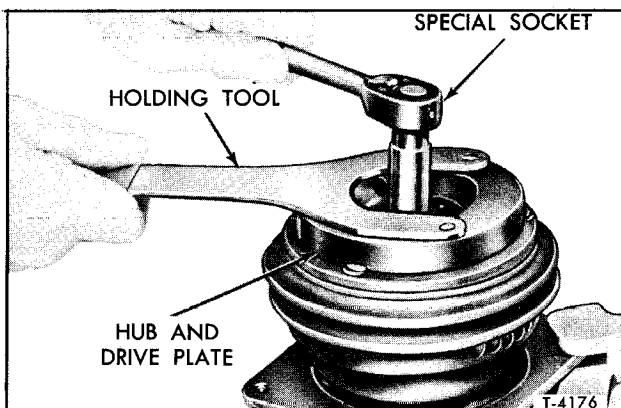

Figure 34—Removing Shaft Locknut

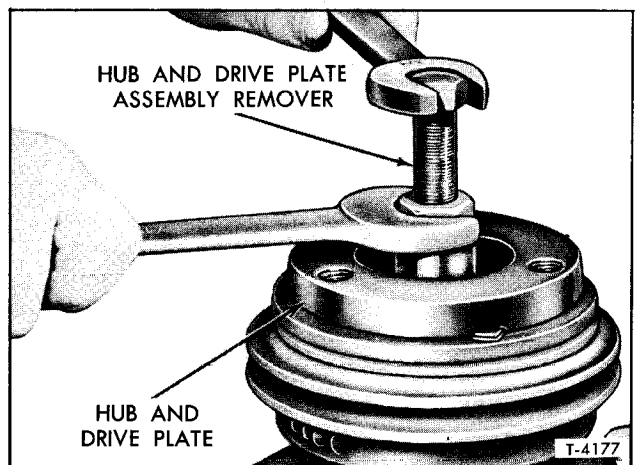
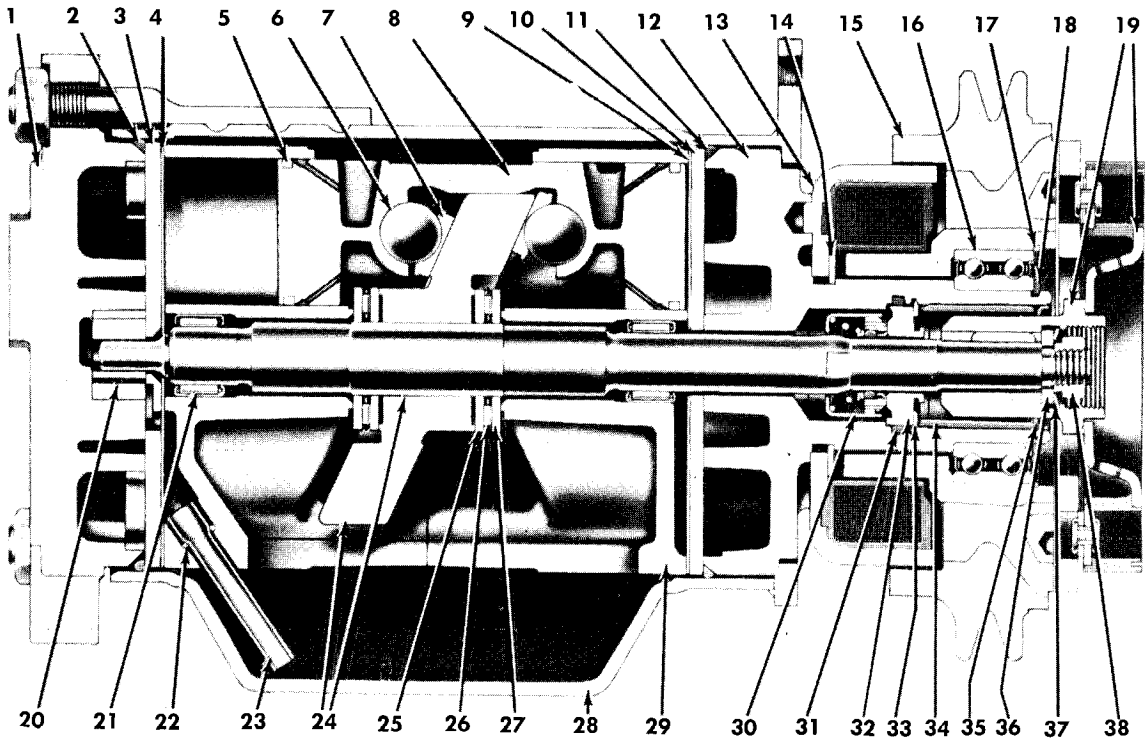

Figure 35—Removing Hub and Drive Plate Assembly



- |  |  |
|--|--|
| 1 Rear Head                            | 20 Oil Pump Gears                      |
| 2 Rear Head to Shell O-ring            | 21 Mainshaft Bearing (Rear)            |
| 3 Rear Discharge Valve Plate           | 22 Oil Inlet Tube O-ring               |
| 4 Rear Suction Reed Plate              | 23 Oil Inlet Tube                      |
| 5 Piston Ring                          | 24 Wobble Plate and Mainshaft Assembly |
| 6 Piston Drive Ball                    | 25 Thrust Race                         |
| 7 Ball Seat                            | 26 Thrust Bearing                      |
| 8 Piston                               | 27 Thrust Race                         |
| 9 Front Suction Reed Plate             | 28 Compressor Shell                    |
| 10 Front Discharge Valve Plate         | 29 Cylinder Assembly                   |
| 11 Front Head to Shell O-ring          | 30 Shaft Seal                          |
| 12 Front Head                          | 31 Shaft Seal Seat O-ring              |
| 13 Coil and Housing Assembly           | 32 Shaft Seal Seat                     |
| 14 Coil Housing Retainer Ring          | 33 Shaft Seal Seat Retainer Ring       |
| 15 Pulley and Bearing Assembly         | 34 Felt Sleeve                         |
| 16 Pulley Bearing                      | 35 Felt Sleeve Retainer                |
| 17 Pulley Bearing Retainer Ring        | 36 Spacer                              |
| 18 Pulley and Bearing Retainer Ring    | 37 Clutch Hub Retainer Ring            |
| 19 Clutch Hub and Drive Plate Assembly | 38 Shaft Nut                           |

T-4175

Figure 36-Compressor Cross Sectional View

3. Tool (J-9401) may now be used to remove the hub and drive plate assembly (refer to figure 35).

**NOTE:** Carefully snug tool into place with wrench to insure engagement with threads.

4. Use snap ring pliers (J-5403) to remove the retainer ring (Item 37, figure 36). Then remove the hub spacer.

## INSPECTION

If the frictional surface shows signs of damage due to excessive heat, the hub and drive plate and the pulley should be replaced. Check further for the underlying cause of the damage; i.e., low coil voltage or binding of the compressor internal mechanism.

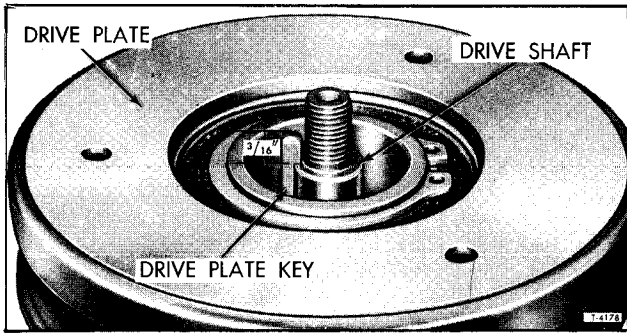

Figure 37-Drive Plate Installed In Keyway

## INSTALLATION

**NOTE:** When hub and drive plate assembly is ready for installation, clean its frictional face with a suitable cleaner.

1. Insert the square hub and drive plate key into the keyway in the drive shaft allowing it to project approximately  $3/16$ " out of the end of the keyway (figure 37).

2. Line up the key in the shaft with the keyway in the hub.

3. Using tool (J-9480-01, figure 38), install the hub and drive plate assembly. Pull the assembly onto the shaft until there is approximately  $3/32$ " space between the frictional surfaces of the drive plate and pulley. (A ZERO thrust race is approximately  $3/32$ " thickness and may be used to roughly gauge this operation.)

**NOTE:** Use tool (J-9403) to hold hub and drive plate if necessary.

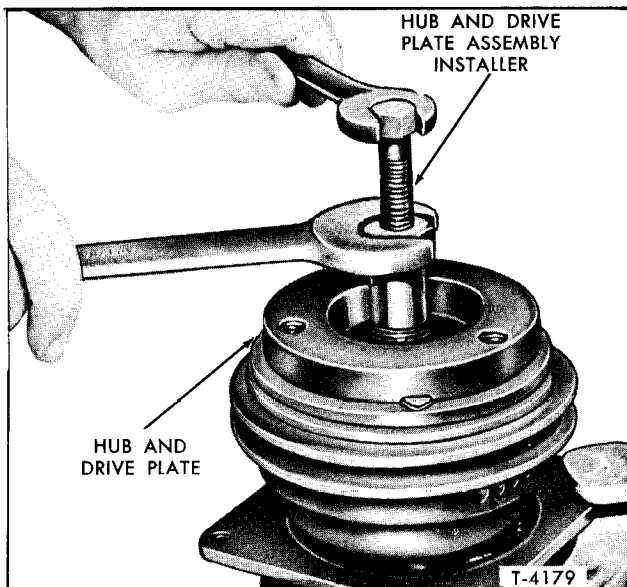

Figure 38-Installing Hub and Drive Plate Assembly

4. Install the hub spacer washer and, using snap ring pliers (J-5403), install the retainer ring (Item 37, figure 36), convex side of ring facing washer.

5. Use tools (J-9399 and J-9403) to install a new lock nut. Tighten the nut to 14-26 foot-pounds torque. Air gap between the frictional faces should now be  $.022$ " to  $.057$ ".

**NOTE:** The shoulder or circular projection on the lock nut must face toward retainer ring.

6. The pulley should now rotate freely.

**CAUTION:** *Never pound or drive the hub and drive plate into position. Always use the proper tools when removing or replacing clutch parts. Failure to do so may result in serious internal compressor damage.*

7. Operate the refrigeration system and rapidly cycle the clutch (by turning the air conditioning off and on at least 20 times at approximately one second intervals) to seat the mating parts of the clutch.

## PULLEY AND BEARING ASSEMBLY

### REMOVAL

1. Remove the hub and drive plate assembly.

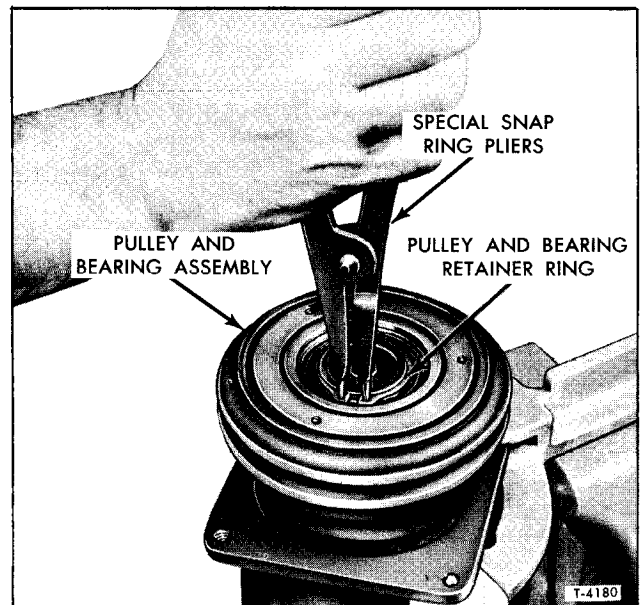

Figure 39-Removing Pulley and Bearing Assembly Retaining Ring



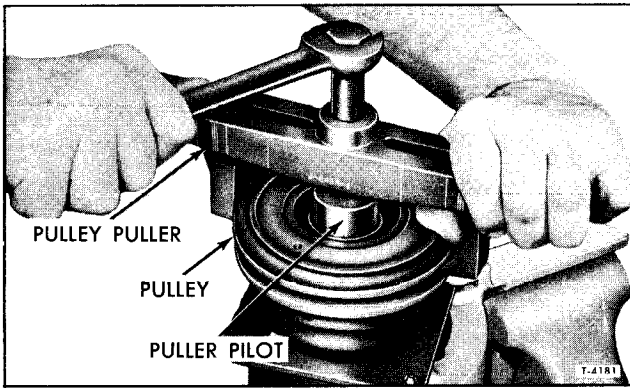

Figure 40-Removing Pulley

2. Using snap ring pliers (J-6435), remove the pulley and bearing retainer ring (figure 39).
3. Remove shaft key.
4. Place puller pilot (J-9395) over the compressor shaft and pull off the pulley assembly using (J-8433) pulley puller (figure 40).

**INSPECTION**

Check the appearance of the pulley and bearing assembly. If the frictional surface of the pulley indicates excessive grooving due to slippage, both the pulley and the clutch hub and drive plate assembly should be replaced. The frictional surfaces of the bearing to be used should be cleaned with a suitable solvent before reinstallation.

**BEARING REPLACEMENT**

1. With the pulley and bearing assembly removed from the compressor, use a sharp pointed instrument to remove the wire retainer ring.
- CAUTION:** *If the bearing is to be reused, be careful not to slip and damage the seal.*
2. From the rear of the pulley, press or drive bearing out of pulley using tool (J-9398) and handle (J-8092).
  3. From the front of the pulley and using tool (J-9481) with handle (J-8092), press or drive the new bearing into the pulley.

**INSTALLATION**

1. Using tool (J-9481), press or drive the pulley and bearing assembly onto the compressor neck. The pulley should now rotate freely.

2. Install retainer ring using snap ring pliers (J-6435).
3. Replace the hub and drive plate assembly. Use proper tools. **DO NOT** drive or pound on the hub assembly.
4. Install the wire bearing retainer ring.

**COIL HOUSING ASSEMBLY**

**REMOVAL**

1. Remove the hub and drive plate assembly, the pulley and bearing assembly, and electrical connector.
2. Scribe the location of the coil housing to the compressor body. This operation is to insure that the electrical terminals will be reassembled in the same position.
3. Using snap ring pliers (J-6435), remove the coil housing retainer ring (figure 41).
4. Remove the coil housing assembly.

**INSPECTION**

Check coil for loose connectors or cracked insu-

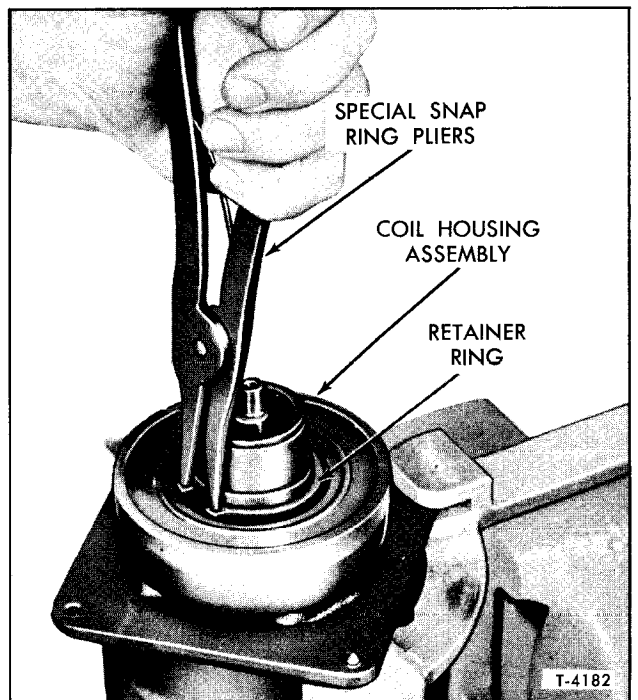

Figure 41-Removing Coil Housing Retainer Ring

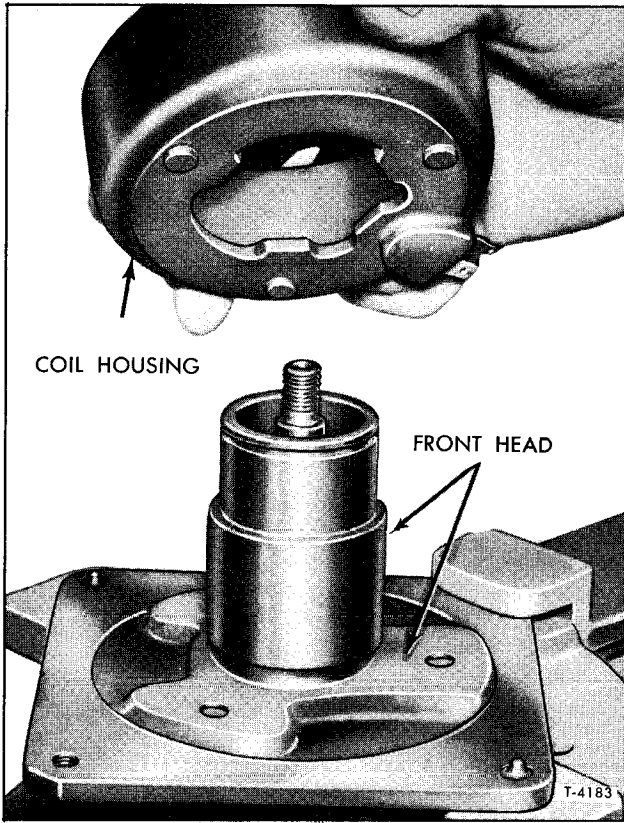

Figure 42—Installing Coil Housing

lation. Amperage should not be more than 3.2 amps at 12 volts D.C. at room temperature.

## INSTALLATION

1. Rotate the coil housing to the correct position as indicated by the scribe marks and the location of the electrical terminals and fit into place (figure 42).

2. Use snap ring pliers (J-6435) to install retainer ring.

**NOTE:** Install flat surface of the retainer ring facing the coil housing.

3. Replace the pulley and bearing assembly and the hub-and drive plate assembly. **DO NOT** drive or pound on the hub assembly.

4. If the compressor is installed in the vehicle, connect the electrical connections.

# COMPRESSOR MAJOR OVERHAUL PROCEDURES

The following service procedures are considered major since the refrigeration system must be completely purged of refrigerant before proceeding and/or because major internal operating and sealing components of the compressor are being disassembled and serviced. A clean workbench, preferably covered with a sheet of clean paper, orderliness in the work area and a place for all parts being removed and replaced is of great importance as is the use of the proper service tools. Any attempt to use make-shift or inadequate equipment may result in damage and/or improper compressor operation.

These procedures are based on the use of the proper service tools and the condition that an adequate stock of service parts is available. This service parts stock should include the following:

1. Major interior mechanism assembly – ready for installation in shell as is.

2. Service cylinder assembly – front and rear halves with main bearings in place and halves dowel pinned together.

3. Standard size piston drive balls.

4. Ball seats – total of 10 sizes, including the ZERO seat.

5. Thrust races – total of 14 sizes, including the ZERO race.

6. Pistons.

7. Mainshaft bearings.

8. Thrust bearings.

9. Compressor shaft and wobble plate.

10. Suction reed valves.

11. Discharge valve plate – front and rear.

12. Seal kit – service – contains all seals and O-rings to be used each time a compressor is rebuilt.

13. Shaft seal kit.

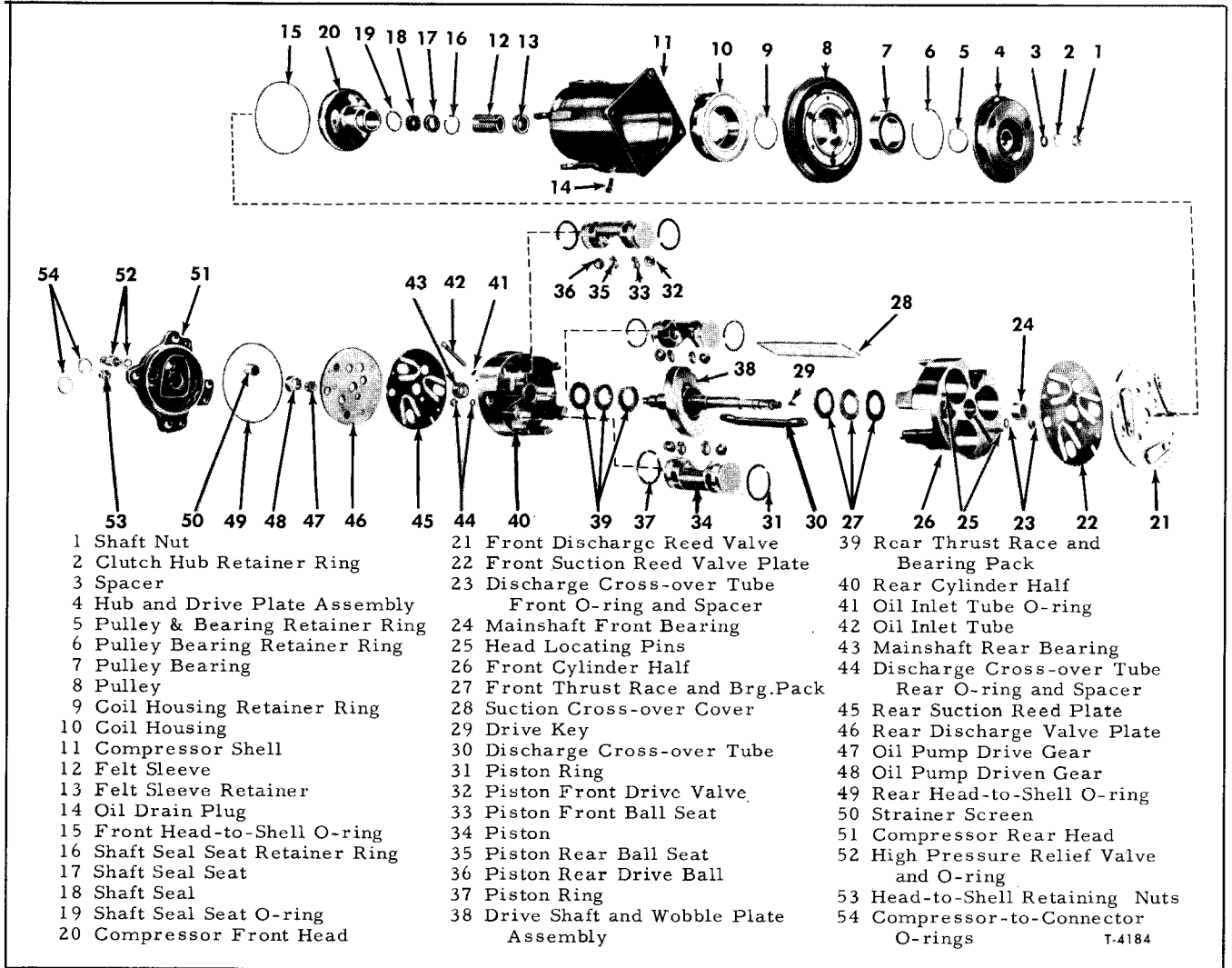

Figure 43-Exploded View of Compressor

- 14. Nuts – head to shell, and shaft.
- 15. Retainer rings – all necessary sizes.
- 16. Cylinder locator (dowel) pins.
- 17. Valve and head locator (dowel) pins.
- 18. Service discharge cross-over tube kit.

All parts required for servicing are protected by a preservation process and packaged in a manner which will eliminate the necessity of cleaning, washing or flushing of the parts. The parts can be used in the mechanism assembly just as they are removed from the service package.

Piston ball seats and shaft thrust races will be identified on the parts themselves to denote their size and dimension.

## SHAFT SEAL ASSEMBLY

When replacing the shaft seal assembly, even if the compressor remains on the vehicle during the operation, it will be necessary to purge the system of refrigerant as outlined earlier in this section.

## REMOVAL

1. After first purging the system of refrigerant, remove the clutch hub and drive plate, and the shaft key as explained previously under "Compressor Minor Overhaul Procedures."

2. Before removing the seal seat and retaining ring, thoroughly clean the area of the neck of the compressor surrounding the shaft to remove all dirt or foreign material. Pry out the felt retaining ring

and remove the felt sleeve. Remove the seal seat retaining ring using snap ring pliers (J-5403).

3. Using tool (J-23128), grasp the flange on the seal seat and lift out the seal seat (figure 45).

4. Remove the seal seat O-ring from the housing bore using tool (J-9553).

5. Engage the tabs on the seal assembly with the locking tangs on tool (J-9392) by pressing down and twisting the tool, then lift the seal out.

## INSPECTION

Check the face of the seal for nicks, gouges, or serrations. If damage of any kind is evident, replace the seal. Be extremely careful that the face of the seal which is to be installed is not scratched or damaged in any way.

Apparent seal leaks are sometimes the result of mispositioning of the wobble plate on the compressor shaft caused by improper procedures during pulley removal or pounding or dropping on the compressor shaft. Check as shown in Figure 44. If measurement is greater than shown, replace the shaft and wobble plate assembly.

## INSTALLATION

1. Engage seal onto the locking tangs of tool (J-9392) (figure 46) and with shaft seal protector tool (J-21303) installed over the end of the shaft, carefully insert the seal and tool over the end of the shaft. Turn seal to engage the flat on the shaft, then remove the tool.

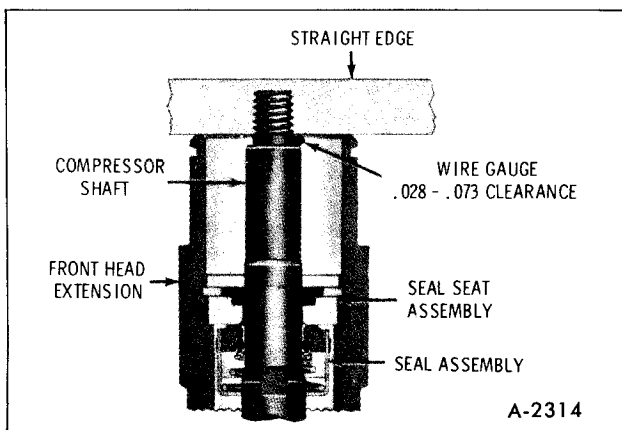

Figure 44—Checking Compressor Shaft and Seal

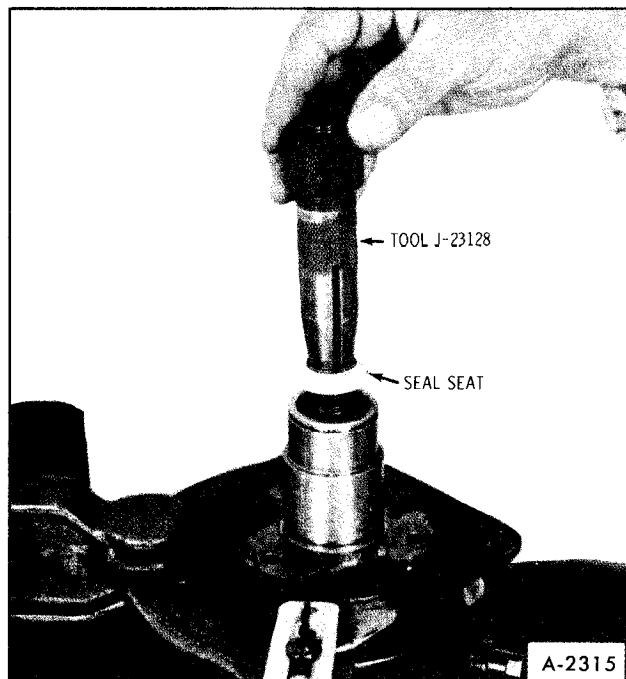

Figure 45—Removing Seal Seat

2. Coat a new O-ring and the interior of the seal cavity, shaft and seal with clean refrigeration oil, and, using tool (J-21508), install the O-ring in its groove just above the seal.

To install the O-ring, place O-ring on tool as shown in Figure 46. Insert the tool fully into the front head bore, press down the slider, twist entire tool to seat O-ring and then remove tool.

3. Using tool (J-23128), grasp the seal seat and set in place on top of the seal.

4. Using snap ring pliers (J-5403), replace the retaining ring. Tap with the palm of the hand on the barrel of tool (J-23128) to press the retainer ring into place.

**NOTE:** Install the retaining ring with the flat surface facing the seal seat.

5. Leak test the compressor as described under "Leak Testing the Compressor" in this manual.

6. Roll the felt into a cylinder and slip it into the neck of the compressor top. With a small screwdriver or similar tool, spread the felt so that the ends butt. Using tool (J-9395), tap the felt retaining ring (flange first) into the compressor neck until flush with the end.

7. Reinstall the clutch hub and drive plate.

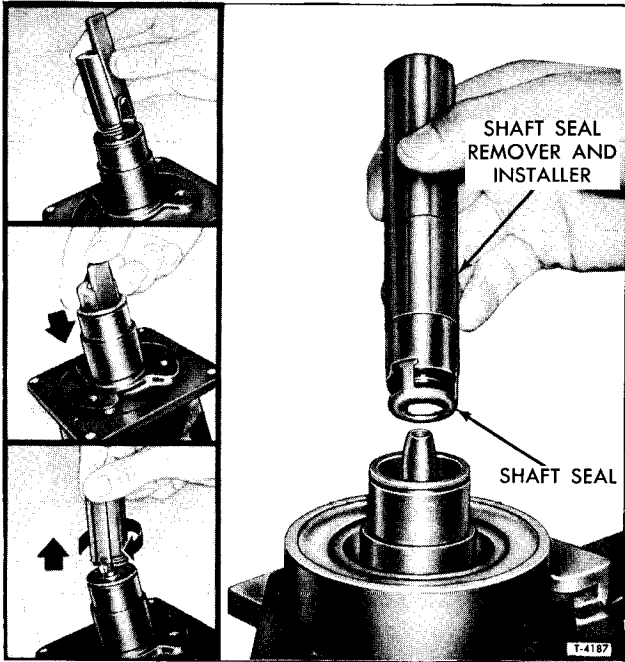

Figure 46—Installing Seal and O-Ring

8. Replace the compressor on the vehicle, if it was previously removed, and evacuate and charge the system.

### PRESSURE RELIEF VALVE

When a faulty pressure relief valve, located in the rear head casting, is encountered, the valve assembly should be removed after purging the system and a new valve and gasket installed. The entire system should then be evacuated and recharged.

## COMPRESSOR REAR HEAD AND INTERNAL MECHANISM

Service operations to the rear head or internal mechanism of the compressor should be performed with the compressor removed from the vehicle to insure that the necessary degree of cleanliness may be maintained.

**IMPORTANT:** Clean hands and a clean bench, preferably covered with clean paper, are of extreme importance.

### REAR HEAD, OIL PUMP AND VALVE ASSEMBLIES

#### Removal

1. Remove the compressor from the vehicle, drain compressor oil into a clean container, clean the

exterior of the compressor case and rear head casting with a suitable solvent and mount the compressor, rear head up, in holding fixture (J-9396) which should then be mounted securely in a vise.

2. Remove the four nuts from the shell studs.

3. Remove the rear head. Examine the teflon surface on the casting webs. If this surface is damaged by nicks or scratches, the head should be replaced.

4. Examine the suction screen in the rear head for any damage or contamination. Clean or replace the screen as necessary.

5. Remove and examine the oil pump gears. If either of the gears shows any wear or damage, replace both gears.

**NOTE:** Keep the ends of the two oil pump gears matched and position the same end toward the discharge plate upon reassembly.

6. Remove the rear head-to-shell O-ring and discard.

7. With two screwdrivers, carefully pry up on the rear discharge valve plate assembly (figure 47). Check for broken reeds or damaged seats and replace entire assembly if such is found.

**CAUTION:** Excessive force during this operation may loosen valve reed retainer rivets.

8. Carefully lift off the rear suction reed valve. Valve must be replaced if any damage is evident.

#### Installation

1. Carefully install the suction reed valve and the rear discharge valve plate over the dowel pins and ports in the cylinder assembly. Proper positioning of the reed plate may be determined by lining up the proper opening in the plate with the discharge cross-over tube opening.

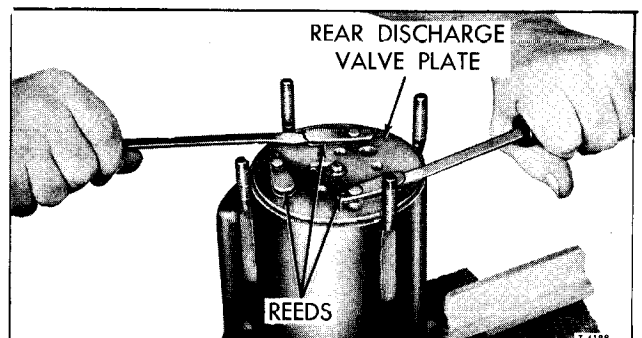

Figure 47—Removing Rear Discharge Valve Plate

2. Position the rear head casting to align with the dowel pins. The two lower mounting pads will be in alignment with the oil sump in the shell. Rotate the cylinder assembly back and forth by hand, if necessary, to permit this alignment. Remove the rear head from this trial assembly.

3. Install the inner oil pump gear over the flat on the shaft and place the outer oil pump gear over the inner gear. Position the outer gear as follows:

- a. Observe the position of the oil sump in the shell.
- b. Locate the approximate centerline of sump pump.
- c. Facing the centerline of the sump and viewing from the sump side (bottom) of the compressor, move the OUTER gear toward the right (side having the oil drain fitting) until it is at approximately 90° (3 o'clock position) from the centerline of the oil sump (figure 48).

4. Coat the head-to-shell O-ring with clean refrigeration oil and generously lubricate the area around the outer edge of the valve plate where the O-ring will be placed. Oil also the oil pump gears, valve reeds and the area where the teflon gasket will contact the valve plate.

5. Install the head-to-shell O-ring.

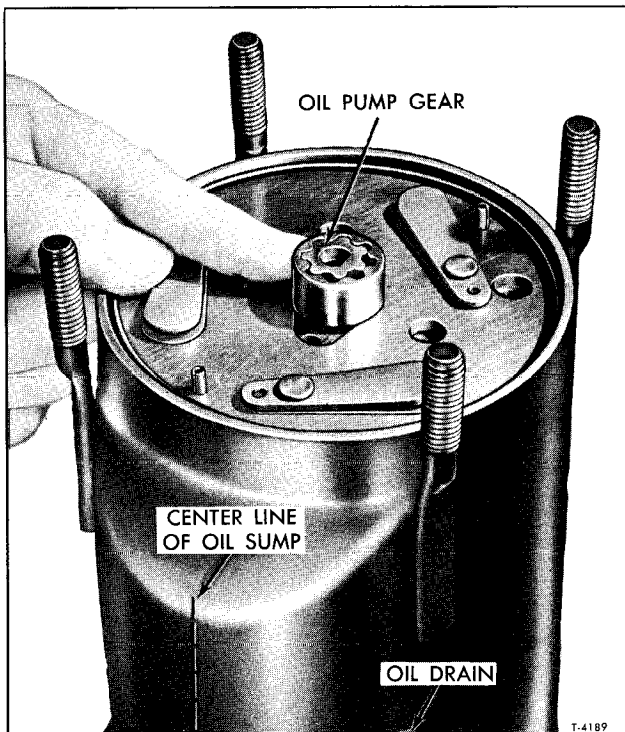

Figure 48—Proper Oil Pump Gear Positioning

6. Be sure that the suction screen is properly positioned in the rear head, then assemble the rear head to the compressor shell being careful not to damage the teflon gasket.

**CAUTION:** *Be sure head does not bind against oil pump gears when being installed.*

7. Install new nuts to the threaded shell studs and tighten to 19-25 foot-pounds torque.

8. Leak test the compressor as outlined under "Leak Testing the Compressor" in this manual.

9. Install compressor in the vehicle.

## MAJOR INTERNAL MECHANISM

The clutch hub and drive plate assembly, drive key, pulley and coil housing should be removed before proceeding with the following compressor disassembly.

### Removal From Shell

1. Remove the rear head, discharge plate and suction reed valve from the compressor as outlined previously under "Rear Head Oil Pump and Valve Assemblies."

2. Remove the oil inlet tube and O-ring with tool (J-5139) as shown in Figure 49.

3. Carefully lay the compressor shell on its side and slide out interior mechanism and front head assembly. Do not hammer or use undue force to

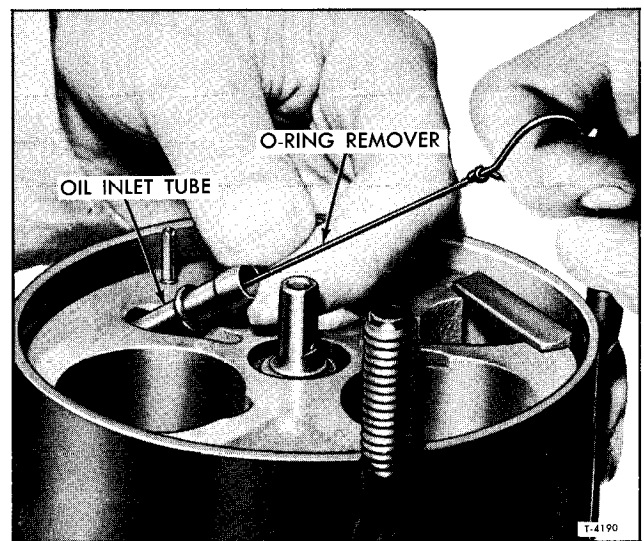

Figure 49—Removing Oil Inlet Tube and O-Ring

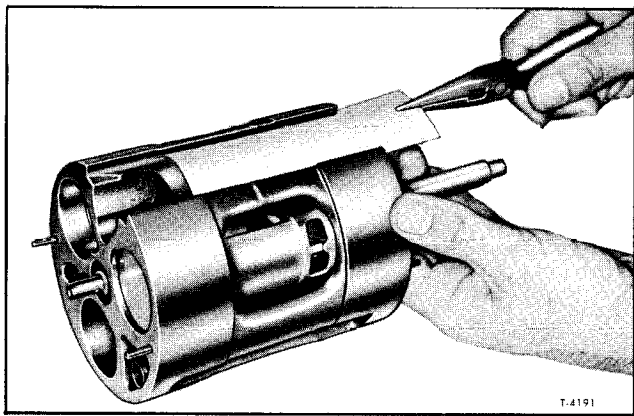

Figure 50—Removing Suction Crossover Cover

remove the mechanism; however, gentle taps on the head casting may aid in removing the assembly.

4. Remove front head casting, front discharge valve plate and suction reed valve from the mechanism. Examine parts for damage and replace if necessary. Check particularly for damage to the teflon surfaces on the front head casting webs.

5. Examine the mechanism for any obvious damage.

6. Remove the suction cross-over cover (figure 50).

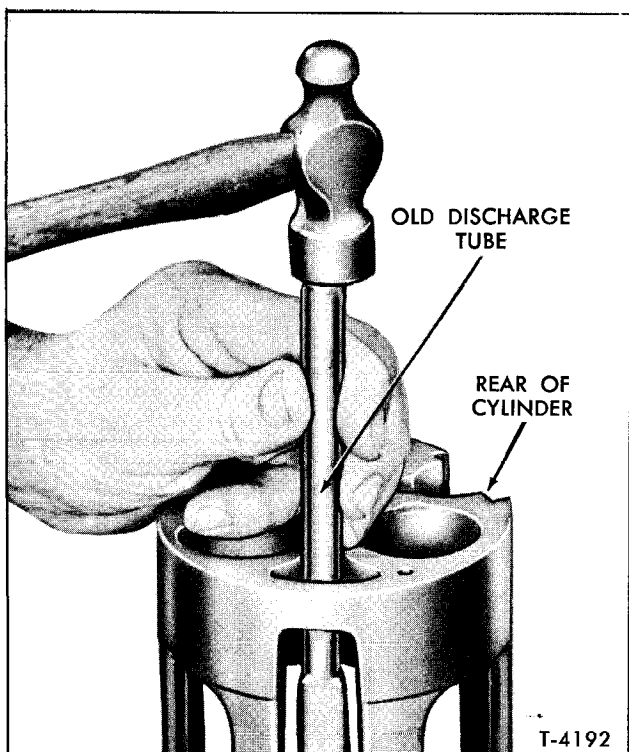

Figure 51—Unseating Discharge Crossover Tube

7. If desired, the mechanism may be assembled in checking cage (J-9397) and operated on a motor test stand, or by some other suitable means, to observe sound level and general operation. Tighten cage nuts evenly to 14-16 foot-pounds torque.

8. Remove mechanism from the cage.

**Disassembly**

If the mechanism has sustained major damage, due possibly to loss of refrigerant and/or oil, it may be necessary to replace it with a complete service interior mechanism assembly rather than to replace individual parts. If further disassembly is considered worthwhile, proceed as follows:

1. Before disassembling the cylinder and mechanism, number the pistons and cylinder locations so that all parts may be replaced in their original location. Pistons and cylinder bores may be identified by numbering them 1, 2, and 3 with a pencil.

2. Use an old discharge tube to drive discharge tube out of cylinder (figure 51). (Drive from REAR of cylinder.)

3. Drive the cylinder halves apart and free from the dowel pins and discharge crossover tube using a fiber block and mallet (figure 52). Discard the discharge cross-over tube.

**NOTE:** Before driving cylinder apart, position wobble plate toward front of compressor in area of the cross-over tube.

4. Carefully remove the rear half of the cylinder from the pistons and set the front cylinder half, with the piston, shaft and wobble plate, in fixture (J-9397).

5. Push up on the shaft and, one assembly at a time, remove pistons, rings, seats and balls placing

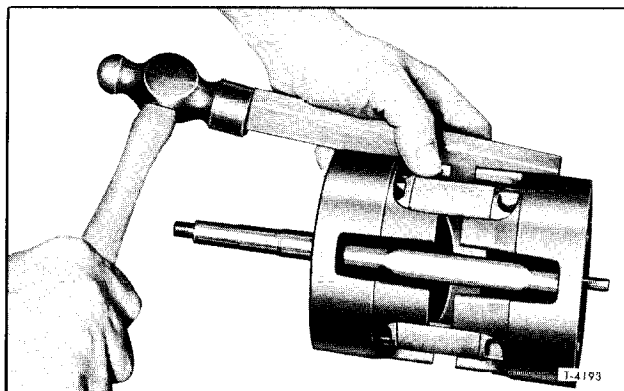

Figure 52—Separating Cylinder Halves

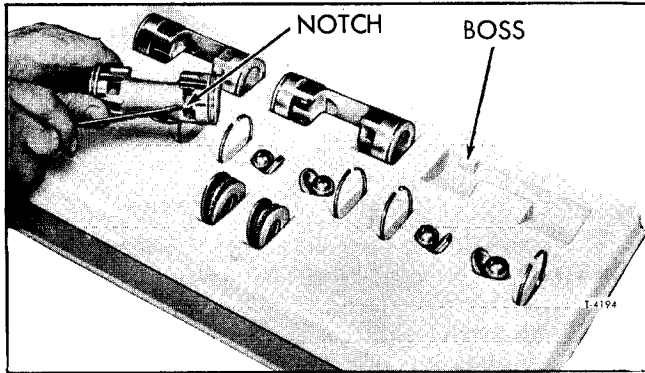

Figure 53—Notch Identifying Front End of Piston

all parts in tray (J-9402) in the compartment associated with the proper end of the piston. Discard all piston ball seats.

**NOTE:** The front of the piston may be identified by a notch in the casting web. See Figure 53. The piston compartments in tray (J-9402) have a boss at this notch location to indicate the front.

6. Remove and inspect all piston rings. Replace all broken or damaged rings. Damaged pistons must also be replaced.

7. Examine piston balls. Replace if they show burning or excessive wear.

8. Remove the rear combination of thrust races and bearing from the shaft and discard all three pieces.

9. Remove the shaft and wobble plate assembly from the front half of the cylinder.

10. Remove the front combination of thrust washers and bearing discard all three pieces.

11. Examine all surfaces of the wobble plate and, if satisfactory, reuse. If it shows signs of wear, replace the shaft and wobble plate as an assembly. Use care not to move wobble plate on the shaft. This is factory set.

12. Examine the front and rear cylinder halves and replace if cylinder bores are deeply scored or damaged.

13. Wash all parts to be reused in a suitable cleaner. Blow dry all parts.

14. If cylinder main bearings are to be replaced they may be removed and reinstalled at this time using tool (J-9432). Drive against the lettered end of the bearings and from the outside of the cylinder. Bearing must not be more than 1/8" below surface.

### Gauging Procedure

The gauging operations which follow have been worked out on a simple basis to establish and provide necessary running clearances. Two gauging procedures are necessary.

The first gauging operation is made to choose the proper size ball seats to provide, at each piston, a .0005" to .0010" total preload between the seats and the wobble plate at the tightest place through the 360 degree rotation of the wobble plate. The bronze ball seats are provided in .0005" variations including a basic ZERO seat.

The second gauging operation, performed at the rear shaft thrust bearing and race pack, is designed to obtain .0005" to .0015" preload between the hub surfaces of the wobble plate and the front and rear hubs of the cylinder. A total of 14 steel thrust races, including a basic ZERO race, are provided in increments of .0005" thickness to provide the required fit. Proper selection of thrust races and ball seats is of extreme importance.

1. Secure from service parts stock:

Four – ZERO thrust races

Three – ZERO ball seats

Two – New thrust bearings

2. Assemble a ZERO thrust race, a new needle thrust bearing and another ZERO thrust race, in that order, to front end of the shaft. (A dab of petroleum jelly will hold the bearing-race pack together and in place of shaft.) Lubricate front and rear faces of wobble plate with refrigeration oil.

3. With the front half of the cylinder assembly resting on tool (J-9397), insert the shaft, threaded end through the front main bearing until the thrust race assembly rests on the front cylinder hub.

4. Assemble a ZERO thrust race, a new needle bearing and a second ZERO thrust race in that order, to the rear of the shaft.

5. Apply a light smear of clean petroleum jelly to the ball pockets of each of the three pistons.

6. Place the balls in the piston pockets. The petroleum jelly will hold the balls in place.

7. Apply a light smear of petroleum jelly to the cavity of three new ZERO ball seats and place one seat over each front piston ball. There should now be a ball and seat in the front ball pocket of each piston and a ball only in the rear ball pocket.



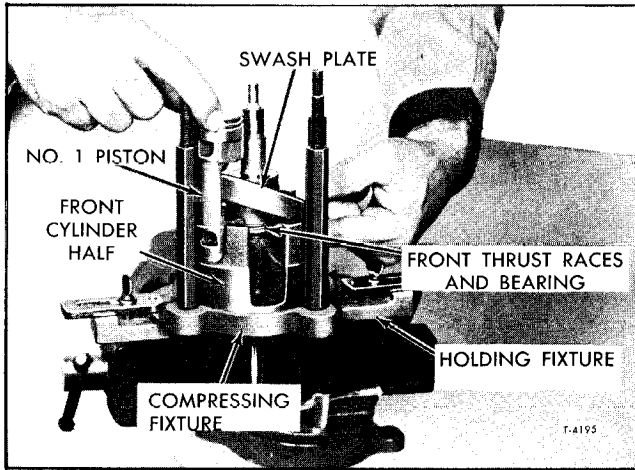

Figure 54—Installing Piston Front Ball and Seat and Rear Ball

**NOTE:** DO NOT assemble any of the piston rings at this time.

8. Rotate the shaft and wobble plate until the high point of the wobble plate is directly over the cylinder bore previously designated as No. 1. Lift up slightly on the shaft and wobble plate assembly, insert the front (notched) end of the No. 1 piston into the cylinder bore, and at the same time, place the front ball and seat and the rear ball only over the wobble plate (figure 54). Hold front thrust bearing pack tight against wobble plate hub while lifting shaft.

9. Repeat this operation with pistons Nos. 2 and 3.

10. Align the rear head casting with bores, suction passage, discharge cross-over holes, and dowel pins. Tap into place, using a plastic block and mallet (figure 55).

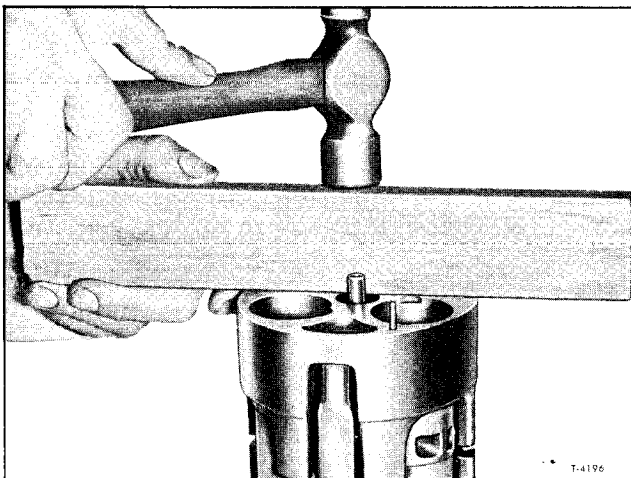

Figure 55—Assembling Cylinder Halves

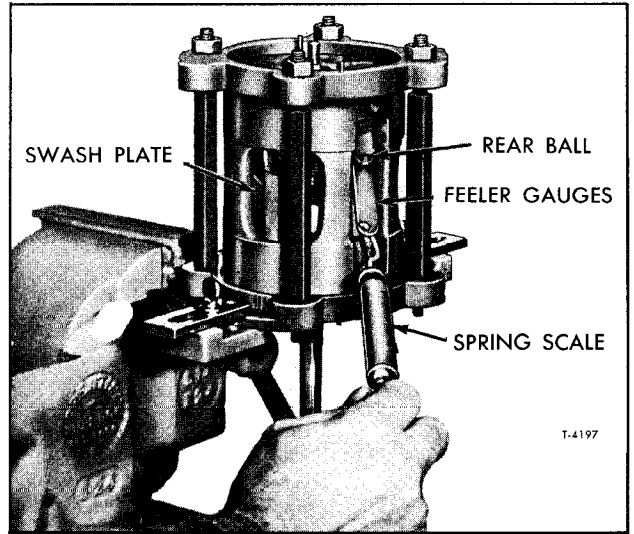

Figure 56—Checking Clearance Between Rear Ball and Wobble Plate

11. Place the cylinder assembly in the checking cage with the front of the compressor shaft pointing up, positioning the discharge tube opening between the cage bolts. This will provide access for the feeler gauge. Assemble the cage and tighten all nuts evenly to 14-16 foot-pounds torque.

12. Use a leaf-type feeler gauge and a suitable spring scale to check clearance between the REAR ball and the wobble plate (figure 56) of the No. 1 piston. Use a suitable combination of feeler gauge leaves until 4 to 8 ounces of force is required to pull gauge from between the ball and the plate.

**NOTE:** Use undamaged feeler gauges generously lubricated with refrigeration oil. Support the spring scale so that only the actual force required to pull the feeler gauge free is measured.

13. Rotate the shaft approximately 120 degrees and again check with a feeler gauge between the parts. Rotate the shaft another 120 degrees and make a third check. From this total of three feeler gauge checks, use the MINIMUM reading to select a numbered seat to correspond to the feeler gauge reading (i.e. - if minimum reading was .019", use a No. 19 seat. If reading was .0195", use a No. 19-1/2 seat). Place this seat in the parts tray in the compartment corresponding to the rear ball position of the No. 1 piston.

14. Repeat the operation described in Steps 12 and 13 for pistons No. 2 and No. 3.

15. The next gauging operation is to determine the space between the REAR thrust bearing and the upper (outer) rear thrust race. Use a suitable combination of feeler gauge leaves so that 4 to 8 ounces of force is required to pull gauge free (figure 57). Select

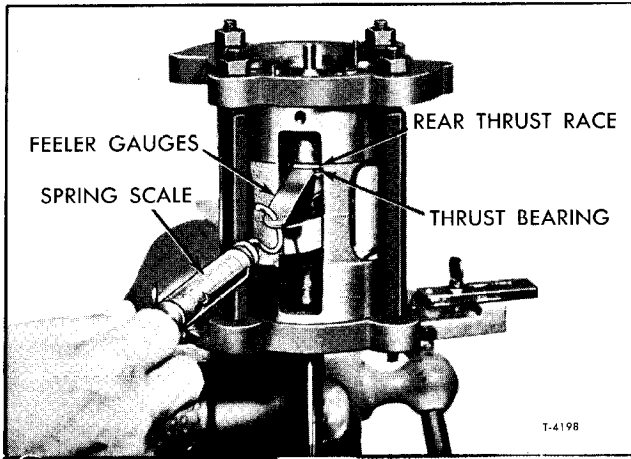

Figure 57—Checking Clearance Between Rear Thrust Bearing and Outer Thrust Race

a numbered thrust race to correspond to this feeler gauge reading and place this race in parts tray in the rear thrust race compartment.

16. Loosen the nuts and ring from the checking cage.

17. Drive the cylinder halves apart, using a fiber block and mallet.

18. Carefully remove the rear half of the cylinder and set the front half (including the pistons and shaft and wobble plate assembly) on fixture (J-9397).

19. Carefully remove one piston at a time from the wobble plate and the front half of the cylinder. Transfer each piston, ball and seat to its proper place in the parts tray along with the numbered rear seat chosen in Steps 12, 13 and 14.

**CAUTION:** *When the balls and seat are removed from the piston, be sure that they are placed in the proper parts tray pocket so as not to lose the relationship of the balls and seats to the proper end of the piston.*

20. Remove the rear outer (upper) ZERO thrust race from the compressor shaft and replace it with the numbered thrust race (determined in Step 15 previously) from the parts tray.

**NOTE:** This ZERO thrust race may be put aside for reuse in future gauging and/or rebuild operations.

21. The gauging operations are now complete.

### Assembly

After properly performing the gauging procedure and choosing the correct ball seats and thrust races

as outlined under "Gauging Procedure," the cylinder assembly may be reassembled. Be sure to install all new seals and O-rings. All are included in the compressor seal service kit.

### Assembly procedure is as follows:

1. Support the front half of the cylinder assembly on fixture (J-9397) and install the shaft and wobble plate, threaded end down, with its front bearing race pack (ZERO race, bearing and ZERO race) and its rear bearing race pack (ZERO race, bearing, numbered race) if this was not already done at the end of the "Gauging Procedure,"

2. Assemble a piston ring, scraper groove toward the center of the piston, to each end of the three pistons.

3. Apply a light smear of petroleum jelly to the numbered ball seats chosen in the gauging procedure and install all balls and seats (if removed in Step 19 of the gauging procedure) in their proper place in the piston.

4. Rotate the wobble plate so that the high point is above cylinder bore No. 1. Carefully assemble piston No. 1, complete with ball and ZERO seat on the front and ball and numbered seat on the rear, over the wobble plate. Hold front thrust pack tight against wobble plate hub while lifting hub. Compress and enter the piston ring into the front cylinder half.

5. Repeat this operation for pistons No. 2 and No. 3.

6. Assemble one end of a service discharge cross-over tube into the hole in the front cylinder half.

7. Rotate the shaft to position the pistons in a stair-step arrangement, then carefully place the rear cylinder half over the shaft and start the pistons into the cylinder bores.

8. Compress the piston ring on each piston to permit its entrance into the cylinder.

9. When all three pistons and rings are in their respective cylinders, align the end of the discharge cross-over tube with the hole in the rear half of the cylinder.

**NOTE:** Be sure the flattened portion of this tube faces the inside of the compressor to allow for wobble plate clearance.

10. When all parts are in proper alignment, tap with a fiber block and mallet to seat the rear half of the cylinder over the locating dowel pins. If necessary, clamp the cylinder in compressing fixture (J-

9397) to complete drawing the cylinder halves together.

11. Generously lubricate all moving parts with clean refrigeration oil and check for free rotation of the parts.

**NOTE:** It may be desirable to clamp the cylinder assembly in compressing fixture (J-9397) and check on the motor test stand for proper operation before proceeding further. If any improper operation is observed, the mechanism should be regauged to insure proper operation. Complete the assembly procedure when correct operation is obtained.

12. Replace the suction cross-over cover as shown in Figure 58. Compress the cover as shown to start it into the slot and then press it in until flush on both ends.

### Installation Into Shell

1. Support the cylinder on fixture (J-9521) with the threaded end of the shaft up.

2. Assemble the two dowel pins in the front cylinder if they are not already in place.

**NOTE:** A rod drilled 1/4" deep to the O.D. of the dowel pins will aid in installing.

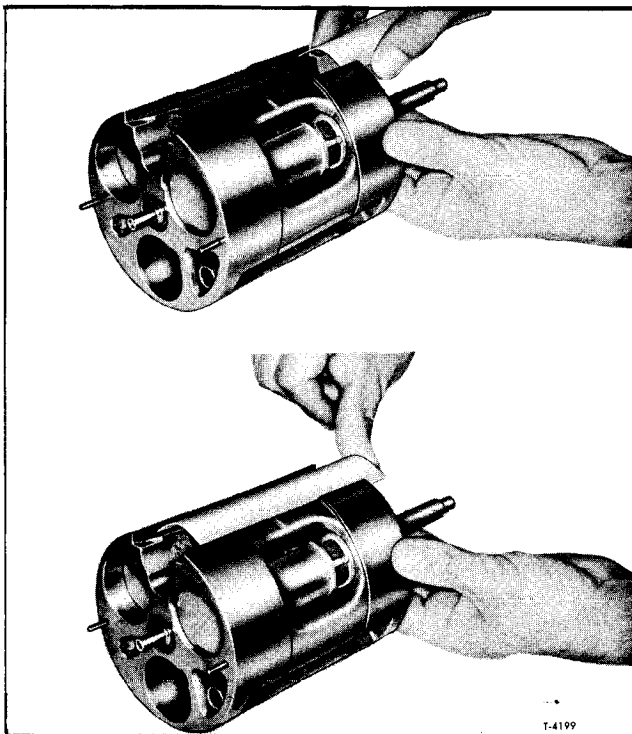

Figure 58—Installing Suction Crossover Cover

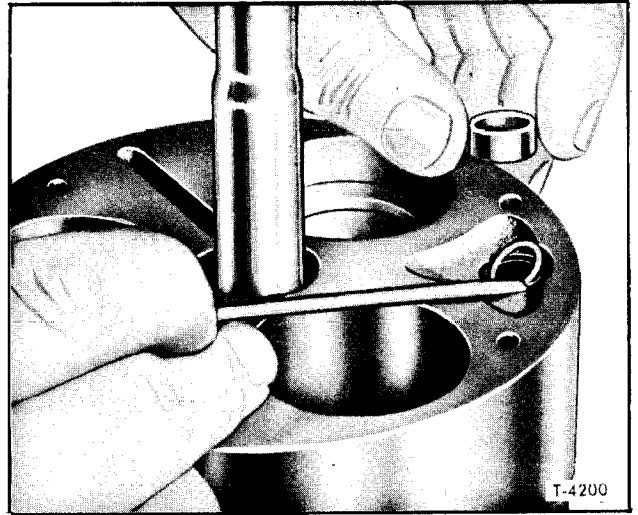

Figure 59—Installing Discharge Crossover Tube, Front O-Ring, and Spacer

3. Install the discharge cross-over tube front O-ring and spacer (figure 59).

4. Aligning the dowel pin holes, discharge cross-over and oil return slot, assemble the suction reed valve to the front end of the cylinder.

5. Assemble the front discharge valve plate, aligning the holes with the dowel pins and proper opening in the head.

**NOTE:** The front discharge plate has a larger diameter hole in the center than the rear discharge plate.

6. Check the teflon surface on the compressor front head casting webs and replace the entire casting if there is any evidence of damage. Discard the O-ring.

7. Coat the valve plate with clean refrigeration oil. Rotate the front head casting until it is properly positioned over the discharge reed retainers and dowel pins, then set it in place (being careful not to damage the teflon surfaces) and seat it over dowels with light mallet taps.

**NOTE:** Dowel pin and hole location can be marked with pencil to aid in locating the proper position.

8. Apply clean refrigeration oil to a new O-ring and O-ring groove at the lower edge of the front head casting and carefully assemble the O-ring in the groove.

9. Coat the inside machined surfaces of the compressor shell with refrigeration oil.

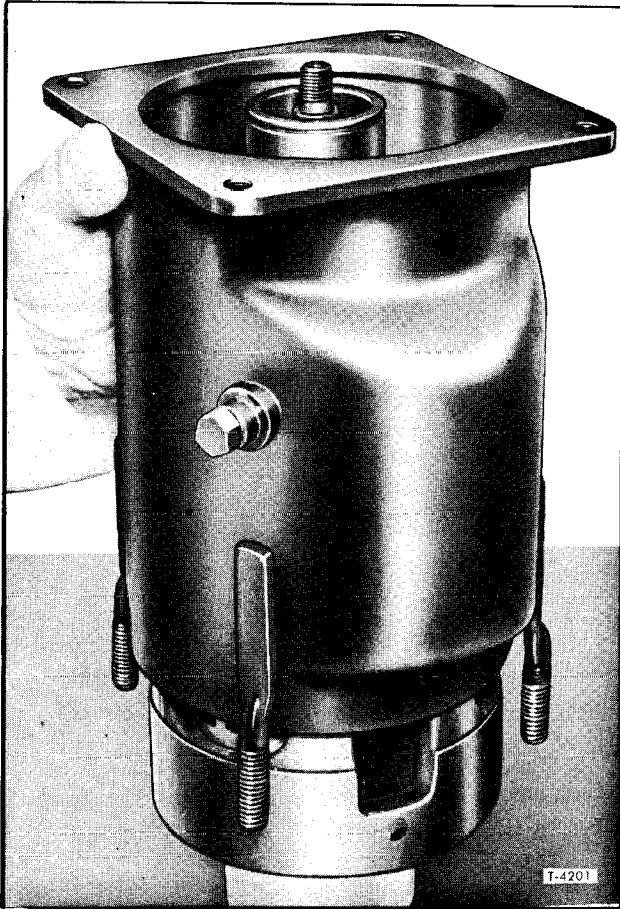

Figure 60—Installing Shell Over Internal Mechanism

10. Locate the oil intake tube in the rear discharge plate. Line up the oil sump with this hole location and slide the shell down over the mechanism while supporting the mechanism on support block (J-9521, figure 60).

11. Place compressor holding fixture (J-9396) in a vise and, carefully inverting the compressor shell with the mechanism inside, mount the front compressor flange on the support bracket.

12. Place a new O-ring in the oil intake tube hole applying clean refrigeration oil to the oil intake tube hole and the O-ring. Rotating the compressor mechanism to line up with the hole in the compressor oil sump baffle, install the pickup tube. Be sure that the O-ring and intake tube are properly seated.

13. Assemble the dowel pins into the rear cylinder.

14. Install the discharge cross-over tube rear O-ring and spacer.

15. Replace the rear suction reed valve, rear discharge valve plate, oil pump gears, rear head and head nuts as outlined previously under "Rear Head and Reed Assemblies – Installation."

## LEAK TESTING THE COMPRESSOR

Whenever service operations are performed on the compressor shaft seal assembly or on the interior mechanism, use the following procedure to leak test the reassembled compressor.

1. Install O-rings and cover plate (J-9527) over the suction and discharge ports of the compressor head.

2. Hook up a Refrigerant-12 container and

charging line using adapter (J-5420) to cover plate fitting over the suction port. Charge the compressor up to can pressure, then leak test compressor with a leak detector. Turn off the refrigerant container valve. Transfer gauge line and adapter to cover plate fitting over the discharge port and repeat the procedure outlined in Step 2.

3. Correct any leaks present.

## AIR CONDITIONING DIAGNOSIS

**NOTE:** Refer to Figures 61-63 for diagnosis details.

### REFRIGERANT SYSTEM

The following is a description of the type of symptom each refrigerant component will evidence if a defect occurs:

### COMPRESSOR

A compressor defect will appear in one of four ways: Noise, seizure, leakage, or low discharge pressure.

**NOTE:** Resonant compressor noises are not cause for alarm; however, irregular noise or rat-

tles may indicate broken parts or excessive clearances due to wear. To check seizure, deenergize the magnetic clutch and check to see if drive plate can be rotated. If rotation is impossible, compressor is seized (See "False Compressor Seizure"). To check for a leak, refer to leak testing earlier in this section. Low discharge pressure may be due to a faulty internal seal of the compressor, or a restriction in the compressor.

Low discharge pressure may also be due to an insufficient refrigerant charge or a restriction elsewhere in the system. These possibilities should be checked prior to servicing the compressor. If the compressor is inoperative, but is not seized, check to see if current is being supplied to the magnetic clutch coil terminals.

## CONDENSER

A condenser may be defective in two ways: it may leak, or it may be restricted. A condenser restriction will result in excessive compressor discharge pressure. If a partial restriction is present, sometimes ice or frost will form immediately after the restriction as the refrigerant expands after passing through the restriction. If air flow through the condenser or radiator is blocked, high discharge pressures will result. During normal condenser operation, the outlet pipe will be slightly cooler than the inlet pipe.

## RECEIVER-DEHYDRATOR

A defective receiver-dehydrator may be due to a restriction inside the body of the unit. A restriction at the inlet to the receiver-dehydrator will cause high head pressures. Outlet tube restrictions will be indicated by low head pressures and little or no cooling. An excessively cold receiver-dehydrator outlet may be indicative of a restriction.

## EXPANSION VALVE

A malfunction of the expansion valve will be caused by one of the following conditions: Valve stuck open, valve stuck closed, broken power element, a restricted screen or an improperly located or installed power element bulb. The first three conditions require valve replacement. The last two may be corrected by replacing the valve inlet screen and by properly installing the power element bulb.

Attachment of the expansion valve bulb to the evaporator outlet line is very critical. The bulb must be attached tightly to the line and must make good contact with the line along the entire length of the bulb. A loose bulb will result in high low side pressures and poor cooling.

Indications of expansion valve trouble are provided by Performance Test; consult Diagnostic Charts.

### VALVE STUCK OPEN

Noisy Compressor.

No Cooling – Freeze Up.

### VALVE STUCK CLOSED, BROKEN POWER ELEMENT OR PLUGGED SCREEN

Very Low Suction Pressure.

No Cooling.

### POORLY LOCATED POWER ELEMENT BULB

Normal Pressure.

Poor Cooling.

### Diagnosis for Defective Valve

The following procedure must be followed to determine if a malfunction is due to a defective expansion valve.

1. Check to determine if the system will meet the performance test as outlined previously. If the expansion valve is defective, the low pressure readings (evaporator pressure) will be above specifications.

2. The loss of system performance is not as evident when the compressor head pressure is below 200 psi. Therefore, it may be necessary to increase the system head pressure by partially blocking the condenser. Disconnect the blower lead wire and repeat the "performance check" to determine if the evaporator pressure can be obtained.

3. The system will also indicate a low refrigerant charge by bubbles occurring in the sight glass.

## EVAPORATOR

When the evaporator is defective, the trouble will show up as an inadequate supply of cool air. A partially plugged core due to dirt, a cracked case, or a leaking seal will generally be the cause.

### COMPRESSOR DIAGNOSIS

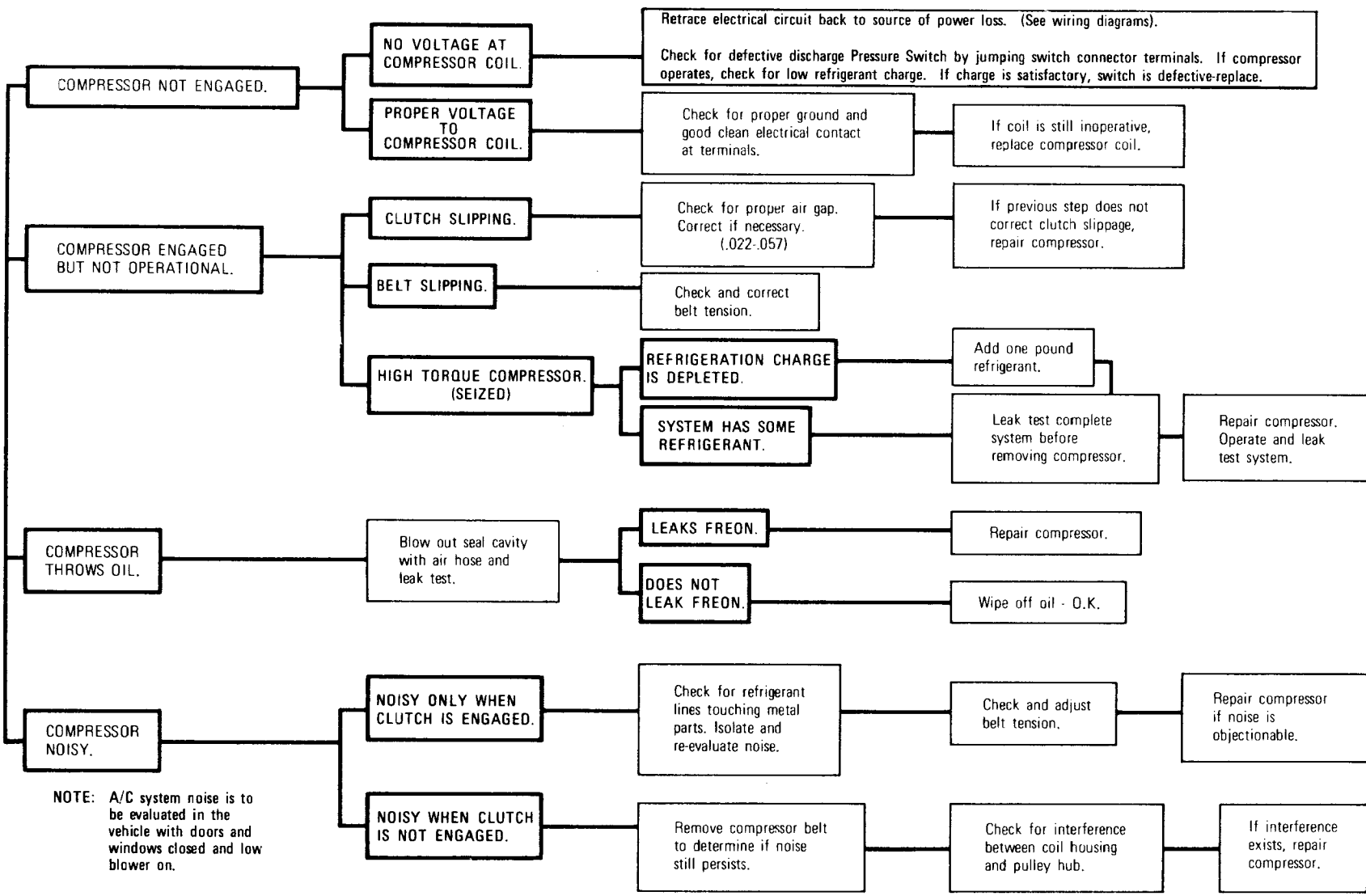

NOTE: A/C system noise is to be evaluated in the vehicle with doors and windows closed and low blower on.

Figure 61-Compressor Diagnosis

# INSUFFICIENT COOLING DIAGNOSIS CHART

The following procedures should be applied before performance testing an A/C System.

1. Check for proper belt installation and tension with J-23600.
2. Check for proper clutch coil terminal connector installation.
3. Check for clutch air Gap (.022 - .057).
4. Check for broken, burst, or cut hoses. Also check for loose fittings on all components.
5. Check for condenser air blockage due to foreign material.
6. Check for proper air ducting hose connections.
7. Check heater temperature door adjustment, adjust if incorrect.
8. Check evaporator sealing for air leak, repair if leaking.
9. Install pressure gages and thermometer and make performance test.

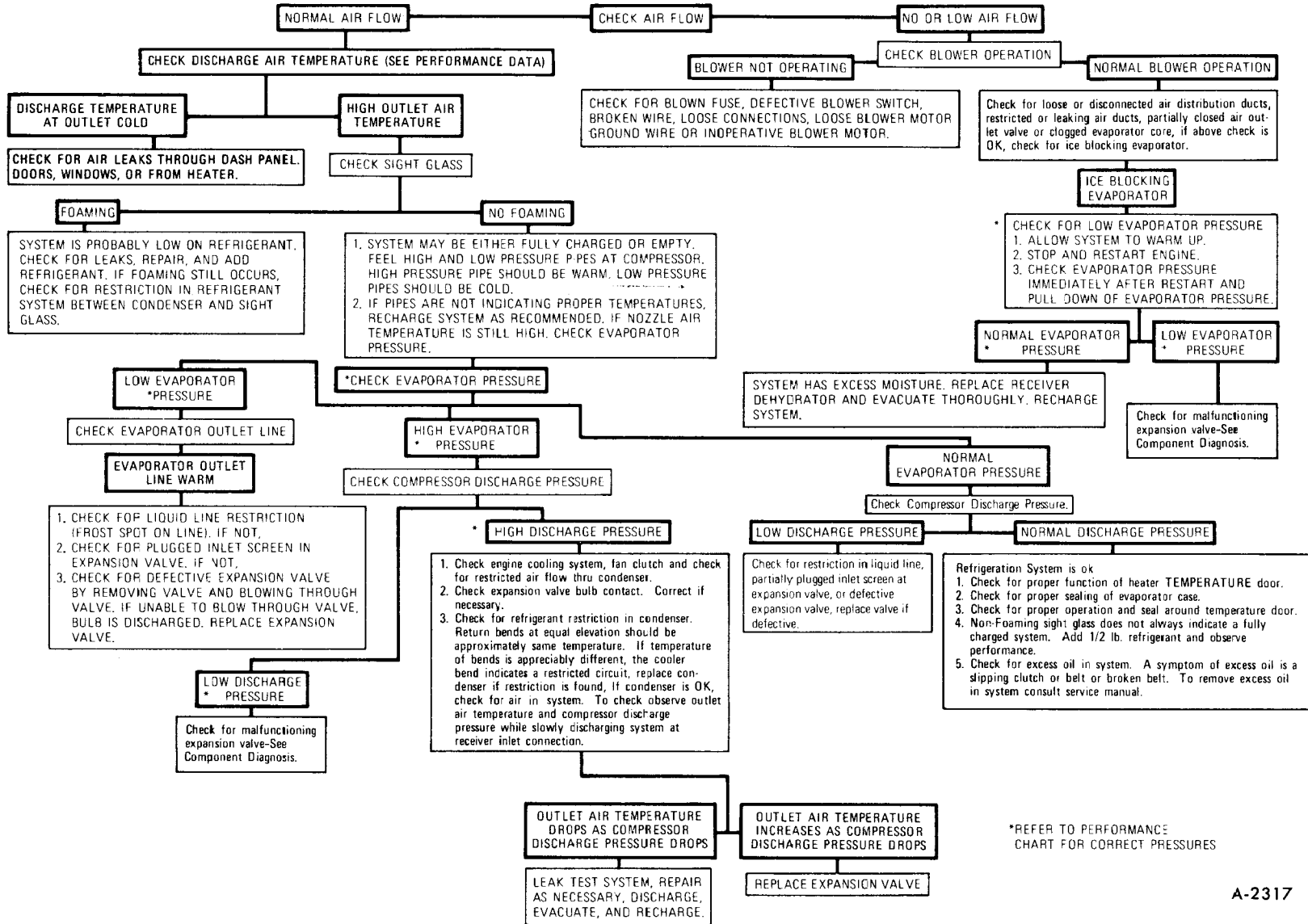

\*REFER TO PERFORMANCE CHART FOR CORRECT PRESSURES

A-2317

Figure 62-Insufficient Cooling Diagnosis

### ELECTRICAL SYSTEM DIAGNOSTIC CHART

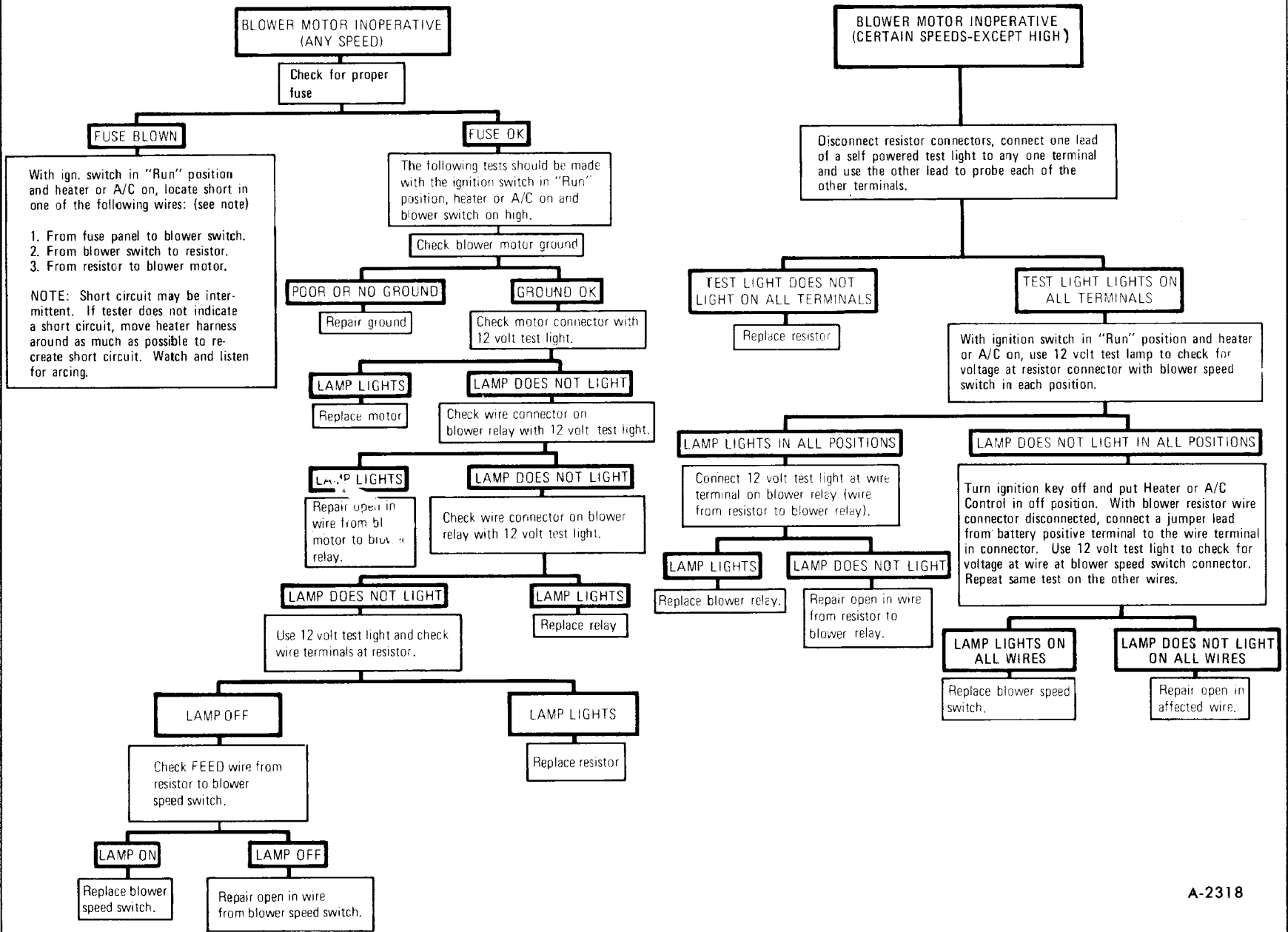

Figure 63-Electrical System Diagnosis



## REFRIGERANT LINE RESTRICTIONS

Restrictions in the refrigerant lines will be indicated as follows:

1. Suction Line – A restricted suction line will cause low suction pressure at the compressor, low discharge pressure and little or no cooling.

2. Discharge Line – A restriction in the discharge line generally will cause the pressure relief valve to open.

3. Liquid Line – A liquid line restriction will be evidenced by low discharge and suction pressure, and insufficient cooling.

## SIGHT GLASS DIAGNOSIS

At temperatures higher than 70 degrees F, the sight glass may indicate whether the refrigerant charge is sufficient. A shortage of liquid refrigerant is indicated after about five minutes of compressor operation by the appearance of slow-moving bubbles (vapor) or a broken column of refrigerant under the glass. Continuous bubbles may appear in a properly charged system on a cool day. This is a normal situation. If the sight glass is generally clear and performance is satisfactory, occasional bubbles do not indicate refrigerant shortage.

If the sight glass consistently shows foaming or a broken liquid column, it should be observed after partially blocking the air to the condenser. If under this condition the sight glass clears and the performance is otherwise satisfactory, the charge shall be considered adequate.

In all instances where the indications of refrigerant shortage continues, additional refrigerant should be added in 1/4 lb. increments until the sight glass is clear. An additional charge of 1/2 lb. should be added as a reserve after the glass clears. In no case should the system be overcharged.

## ELECTRICAL SYSTEM

For electrical connections and routings, refer to the wiring diagram at the end of the manual. Also see Figure 63.

## VACUUM SYSTEM DIAGNOSIS

Start the engine and allow it to idle – move the selector lever to each position and refer to the vacuum diagrams and operational charts for proper airflow, air door functioning and vacuum circuits. If airflow is not out of the proper outlets at each selector lever position, then proceed as follows:

1. Check for good hose connection – at the vacuum actuators, control head valve, reservoir, tees, etc.

2. Check the vacuum source circuit as follows:

Install vacuum tee and gauge (with restrictor) at the vacuum tank outlet (see Vacuum Diagram). Idle the engine and read the vacuum (a normal vacuum is equivalent to manifold vacuum) at all selector lever positions.

a. Vacuum Less Than Normal At All Positions –

Remove the tee and connect the vacuum gauge line directly to the tank – read the vacuum. If still low, then the problem lies in the feed circuit, the feed circuit to the tank or in the tank itself. If vacuum is now normal, then the problem lies downstream.

b. Vacuum Less Than Normal at Some Positions –

If vacuum was low at one or several of the selector lever positions, a leak is indicated in these circuits.

c. Vacuum Normal at All Positions –

If vacuum was normal and even at all positions, then the malfunction is probably caused by improperly connected or plugged lines or a defective vacuum valve or valves.

3. Specific Vacuum Circuit Check

Place the selector lever in the malfunctioning position and check for vacuum at the pertinent vacuum actuators. If vacuum exists at the actuator but the door does not move, then the actuator is defective or the door is mechanically bound. If low or no vacuum exists at the actuator, then the next step is to determine whether the cause is the vacuum harness or the vacuum valve. Check the vacuum harness first.

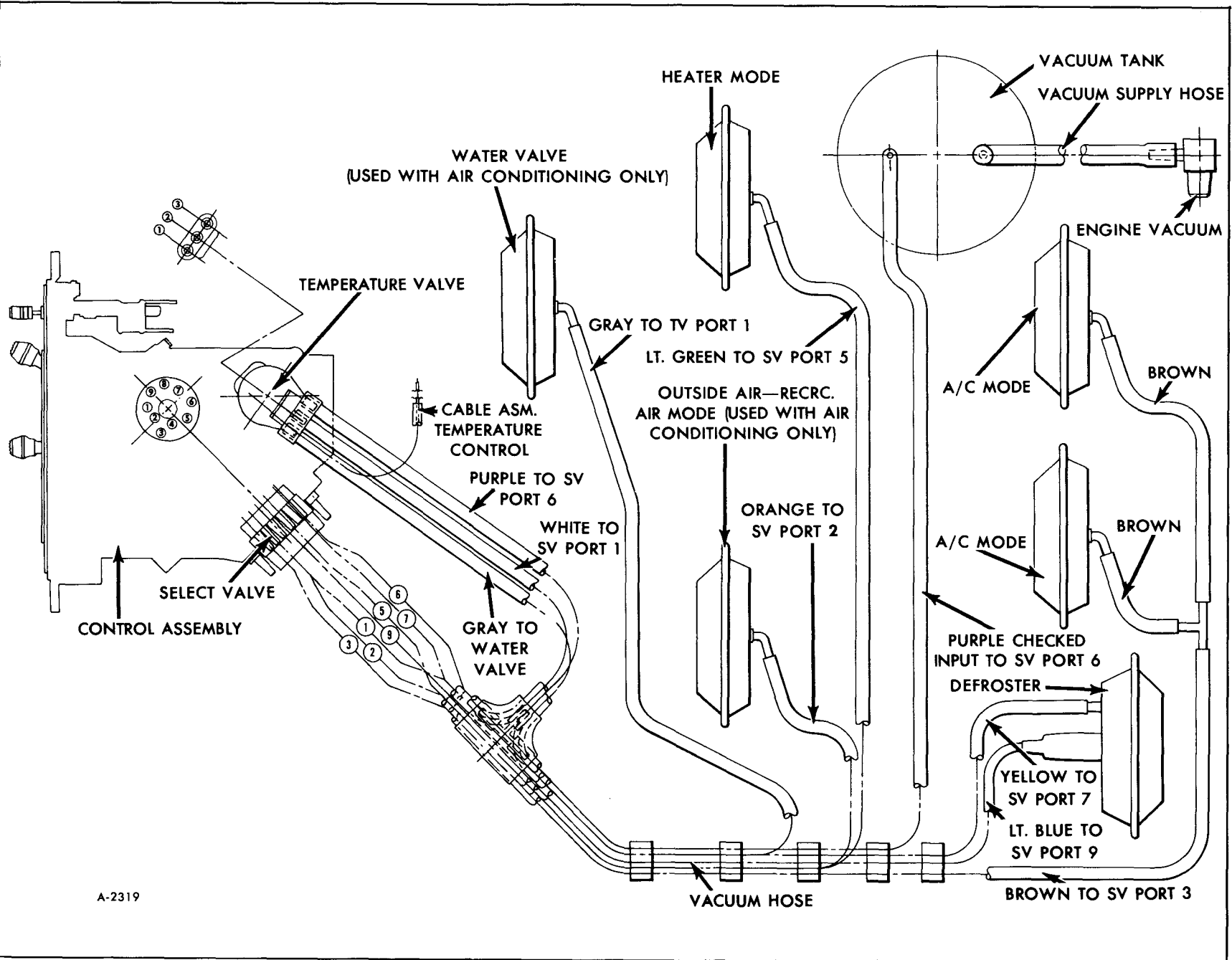

A-2319

Figure 64-Vacuum Control Diagram

# VACUUM CONTROL CHARTS (USE WITH FIGURE 64)

## TEMPERATURE VALVE OPERATING CHART

3	VACUUM INPUT	VAC	VAC	SEAL	PURPLE
2	R. A. OVERRIDE	VAC	VENT	VENT	WHITE
1	HOT WATER VALVE	VAC	VAC	VENT	GRAY
PORT NO.	CONNECTION	RECIRC.	COLD	HOT	COLOR

## SELECT VALVE OPERATING CHART

9	Defrost. Outlet	Vent	Vent	Vent	Vent	Vent	Vac	Lt. Blue
8	No. Connection							
7	Defrost. Bleed	Vent	Vent	Vent	Vac	Vent	Vac	Yellow
6	Checked Input	Seal	Vac	Vac	Vac	Vac	Vac	Purple
5	Htr. Outlet	Vent	Vent	Vac	Vac	Vac	Vac	Lt. Green
4	No Connection							
3	A/C Outlet	Vent	Vac	Vac	Vent	Vac	Vent	Brown
2	O.A. - R.A.	Vent	Conn. 1	Vent	Vent	Vent	Vent	Orange
1	R. A. Over ride	Seal	Conn. 2	Seal	Seal	Seal	Seal	White
Port No.	Connection	Off	A/C	Vent	Heater		Def.	Color

## SPECIAL TOOLS

J-5403	Snap Ring Pliers	J-9432	Needle Bearing Installer
J-5420	Gauge Adapter	J-9459	Gauge Adapter
J-6084	Leak Detector	J-9480	Hub and Drive Plate Assembly Installer
J-6435	Snap Ring Pliers	J-9481	Pulley and Bearing Installer
J-8092	Handle	J-9521	Support Block
J-8433	Pulley Puller	J-9527	Pressure Test Connector
J-9392	Seal Remover	J-9553	O-Ring Remover
J-9395	Puller Pilot	J-21303	Shaft Seal Protector
J-9396	Compressor Holding Fixture	J-21508	Seal Seat O-Ring Installer
J-9397	Compressing Fixture	J-23128	Seal Seat Remover
J-9398	Pulley Bearing Remover	J-23600	Belt Tension Gauge
J-9399	9/16" Thin Wall Socket	J-24095	Oil Inducer
J-9402	Parts Tray	J-24410	Charging Station
J-9403	Spanner Wrench		

## HEATING SYSTEM (WITHOUT AIR CONDITIONING) CONTROL OPERATION

The heating system controls (figure 1) are located on the instrument panel to the right of the steering column. There are three separate controls:

“FAN” lever to control speed of blower operation; “RECIRC,” “COLD,” “HOT” lever to control temperature of air; “OFF,” “VENT,” “HEATER,” “DEF” lever to control direction of air flow. The “FAN” lever works vertically and the other two levers work horizontally. The three levers may be placed in any combined position to deliver the climate conditions most desirable at any given time.

“FAN” – The fan switch has four positions; “OFF” and three blower speeds ranging to “HI” and two unmarked positions between “OFF” and “HI.” The fan will not operate unless the top lever has been moved from the “OFF” position, and in order to operate the fan in the “HI” position the engine must be running.

“OFF,” “VENT,” “HEATER,” “DEF” – With the lever in the “OFF” position the system is off. With the lever in the “VENT” position 100% outside air enters the driver’s compartment. The air enters through the dash mounted outlets and through the heater outlets. Temperature of incoming air may be controlled by moving the “RECIRC,” “COLD,” “HOT” (temperature) lever to desired position. Any one of the three blower speeds may be selected.

With the lever in the “HEATER” position, air will flow through the heater floor distributor outlet (with slight flow of air to the defroster outlet). For maximum heat, move temperature lever to “HOT”

position and “FAN” switch lever to “HI” position. Heating system output can be varied by moving temperature lever and “FAN” lever to different positions.

With the lever in the “DEF” position, the system operates the same as in the “HEATER” position except most of the air flow will be through the defroster outlets at the windshield.

“RECIRC,” “COLD,” “HOT” – This lever, used in conjunction with the system selector lever (“OFF,” “VENT,” “HEATER,” “DEF”) and the “FAN” switch lever, will control the temperature of the output air being distributed.

Clear windshield, rear window, outside mirror, and all side windows of ice and snow before driving vehicle.

Operate blower on “HI” for a few seconds before moving the vehicle, to clear the air intakes of snow.

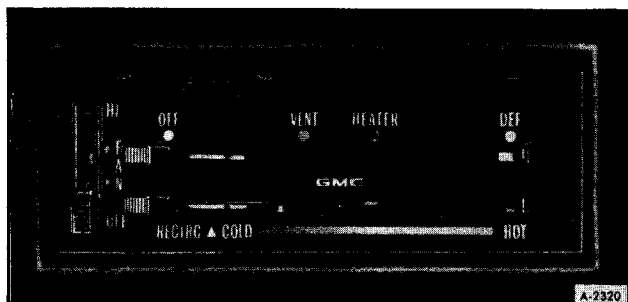

Figure 1—Heating System Controls

## COMPONENT REPLACEMENT

### CONTROL ASSEMBLY

Procedures for the replacement of the heating system control assembly is the same as models equipped with air conditioning. See “Control Assembly Replacement” under air conditioning portion of this section.

### BLOWER COMPONENTS

Replacement procedures for the blower motor, blower relay, and blower resistor are the same as

described in the air conditioning portion of this section.

### HEATER CORE

Replacement procedures for the heater core is the same as for models equipped with air conditioning. See “Evaporator and Heater Core Replacement” in air conditioning portion of this section.

### VACUUM CONTROLS

Before replacing any vacuum control compo-

nents check system for proper operation. Controls are the same as air conditioned models, except for the deletion of the water valve and "Outside Air-Recirc.

Air mode". Lines to these components are simply plugged. For details see vacuum control charts and Figure 64 in air conditioning portion of this section.

# SECTION 2

## FRAME

Contents of this section are listed below:

SUBJECT	PAGE NO.
General.....	2-1
Frame Alignment.....	2-1
Frame Material .....	2-2
Replacing Frame Extension .....	2-2
Body Mounting .....	2-5

### GENERAL

The model 230 and model 260 Motor Home chassis use a channel type frame with a front frame extension, bolted cross members and a rear frame extension. An exploded view of the frame components is shown in Figure 1. A model 260 frame is shown; the model 230 frame differs in the length of the side rail and one less crossmember.

When supporting the Motor Home for servicing on a floorjack or jackstands the vehicle should not be supported at the extreme ends of the frame or at the center of a frame rail. Refer to Section 0 for hoisting and jacking instructions.

In the event the vehicle is damaged in a collision, carefully check for proper frame alignment in addition to steering geometry and wheel alignment.

### FRAME ALIGNMENT

The most convenient way to check frame alignment is to select various corresponding points of measurement on the outside of each side rail and then, by use of a plumb bob, transfer these points to a layout on a level floor. (Note: Flange width may vary and should not be used as a reference point.)

Since the frame is basically made of three different sections, the procedure for checking the frame is as follows:

### CHECKING ALIGNMENT

The diagram shown in Figure 2 can be used to check the alignment of a Motor Home frame that has been distorted.

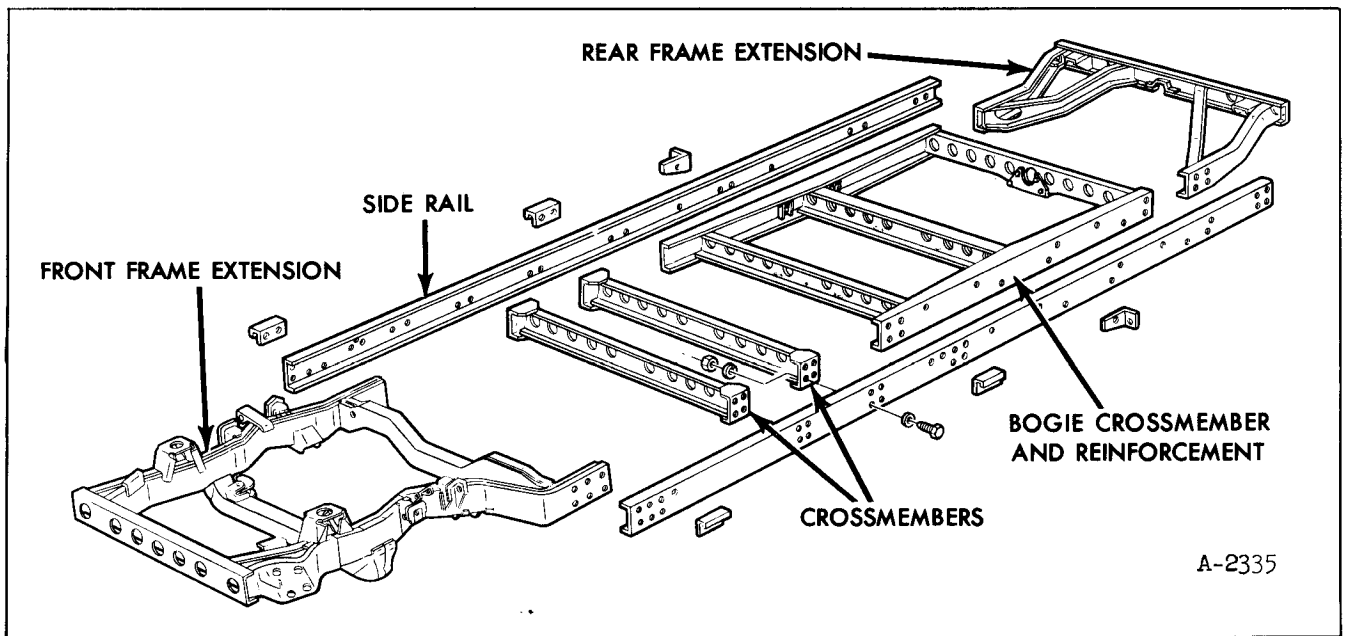

Figure 1—Frame Components

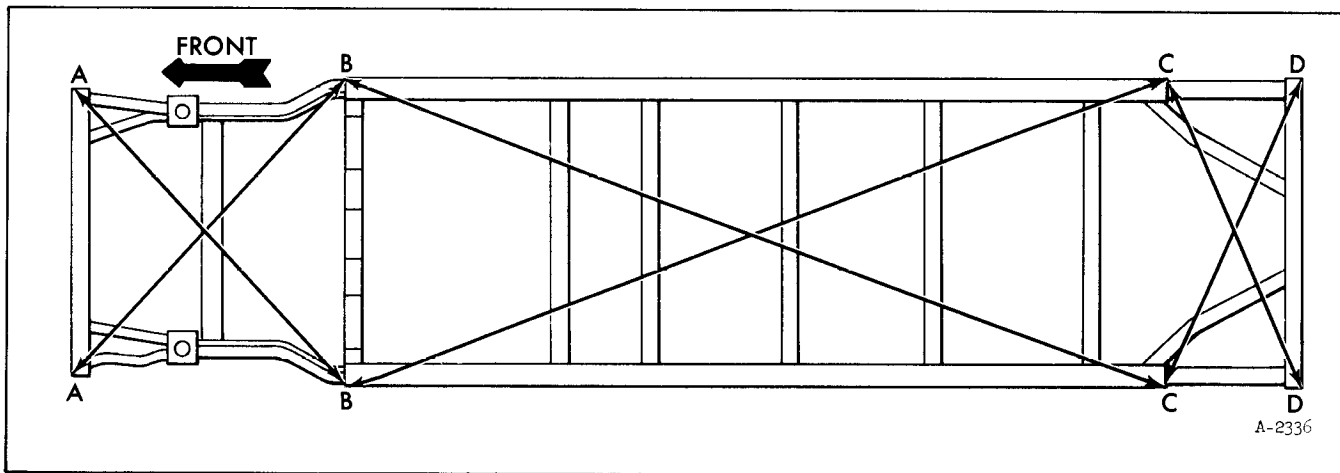

Figure 2-Frame Alignment

Corresponding measurements must be equal within 1/4".

1. Measure A-B. If not equal, front end of frame is misaligned.
2. Measure B-C. If not equal, center portion of frame is misaligned.
3. Measure C-D. If not equal, then rear suspension crossmember is misaligned.

### FRAME REPAIR

In case of collision, frame members can often be satisfactorily straightened to the required limits. However, the front suspension crossmember is made to unusually close limits necessary for proper front wheel alignment; therefore, straightening of this unit may not be successful.

It is possible that the ordinary straightening methods will suffice for minor damage to the front suspension crossmember; however, in case of serious damage or fracture, the entire front suspension crossmember or front frame extension must be replaced. Before the member is replaced, it is essential that the frame alignment be checked, and corrected if necessary.

### FRAME MATERIAL

The frame material is 950-1023-1080 steel. The frame may be welded if necessary using electrodes noted in table 1.

**NOTE:** It is NOT recommended that the frame be welded to repair. Replacement of major components is recommended if there is substantial frame damage – such as from collisions, etc.

### ELECTRODE USAGE WITH FRAME MATERIAL

Material .....	1023-950 steel
Type or Electrode .....	E7018

### REPLACING FRAME EXTENSION

The purpose of this section is to enable a technician to change a front or rear frame extension due to

extensive damage from a collision, etc. It is not recommended that this procedure be used until it is determined that the frame is definitely out of alignment and is unable to be fixed by the usual frame straightening operations.

## FRONT FRAME EXTENSION REMOVAL

The front frame extension should only be replaced if absolutely necessary due to the complexity and amount of labor involved.

**NOTE:** To drain, disconnect, or remove certain components it may be necessary to refer to additional sections in this maintenance manual (such as, draining gas tanks; Refer to Section 8 "Fuel Tank and Exhaust").

### Drain

1. Drain power steering fluid.
2. Drain brake fluid.
3. Release freon from A/C system.
4. Drain gas tanks.
5. Drain engine cooling system.

### Disconnect

1. Fuel Filler hose at front elbow.
2. Hose from tube going to charcoal canister.
3. If two canister are used, disconnect hoses from the one mounted on the stepper.
4. Rear brake line from combination valve.
5. Heater hoses and pre-heater at engine.
6. Vacuum lines at cruise control.
7. Power brake vacuum line.
8. Hose to thermasan switch.
9. Speedometer cable at cruise control (at transmission without cruise control).
10. Accelerator cable at carburetor.
11. Transmission shift cable at transmission.
12. Oil filler tube at front end.
13. Vacuum line at vacuum tank mounted on the side of the heater.
14. Brake lines at master cylinder.
15. Hydraulic lines to windshield wiper motor.

16. Air lines.

### Remove

1. Remove Engine, Transmission, and Final Drive Assembly.
2. Remove mufflers and Y-pipe.
3. Remove torsion bars and rear torsion bar support.
4. Take steering gear off of frame and remove front bumper assembly.
5. Remove batteries and battery box with air tank.
6. Remove parking brake cable from front frame section.
7. Remove thermasan hose from unit on exhaust pipe (if used).
8. Remove front body mount bolts.
9. Remove frame section bolts.
10. Air conditioning compressor and hoses (cap all A/C hoses).
11. Front wheels.
12. Front fender wells.
13. Grille.
14. Lower fiberglass section below grille.
15. Radiator.
16. After the bolts holding the front frame extension are removed it will be possible to pull it forward and down clearing the body. A high capacity floor jack should be used to move the front frame extension forward and down.

## FRONT FRAME EXTENSION INSTALLATION

Installation of the front frame extension is accomplished by reversing the removal procedures.

## REAR FRAME EXTENSION REMOVAL

1. Remove rear bumper by removing both



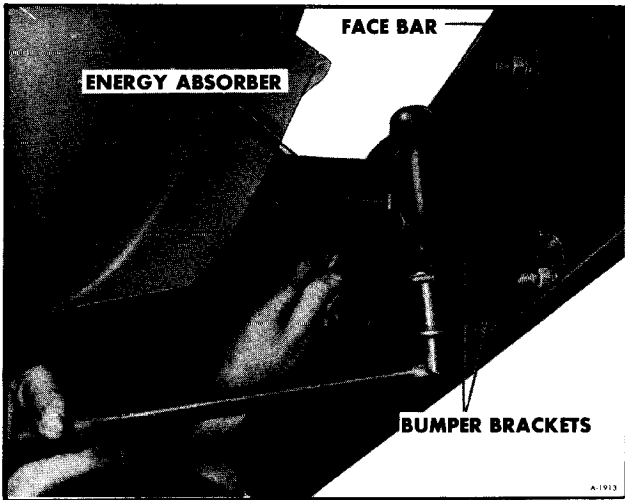

Figure 3-Removing Rear Bumper

bumper bracket thru bolts as shown in Figure 3. Then remove face bar assembly.

2. Remove the 4 bolts and nuts securing energy absorbers to the frame.

3. Remove spare tire carrier from rear crossmember by removing 8 bolts and nuts.

4. Using a small hydraulic or screw jack and a 3 foot wood 2x4, place jack in the middle of floor section using the 2x4 to support the floor weight, lengthwise.

5. Remove the bolt in each rear mounting pad. Location of mounts are shown in Figure 4.

**NOTE:** To reach bolt head inside rear of Motor Home some interior components may have to be removed.

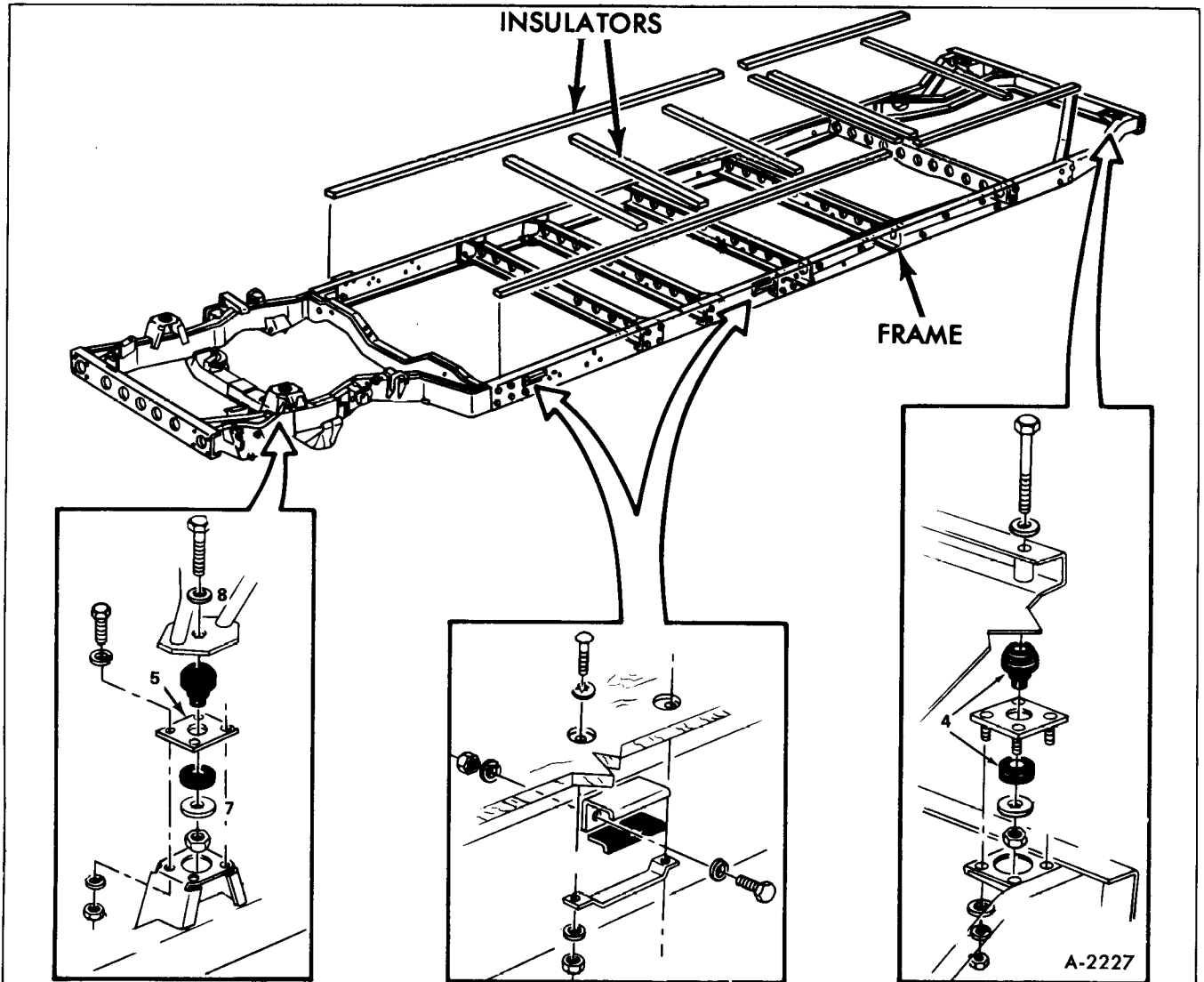

Figure 4-Body Mountings

6. Remove tailpipe from rear section by loosening clamp at slip joint.

7. Drain water from water supply tank.

8. Remove holding tank dump pipe from retaining clamp on rear crossmember.

9. Remove motor generator assembly (if so equipped).

10. Remove 8 nuts and bolts securing rear frame extension to side rails.

11. Slide out rear frame extension.

## REAR FRAME EXTENSION INSTALLATION

Installation of the rear frame extension is accomplished by reversing the removal procedures.

## BODY MOUNTING

Should it become necessary to replace any body mounting components, refer to figure 4. Front and rear body mount nut torque is 50 - 60 foot-pounds.

If any of the insulators between the frame and body must be replaced, be sure the old insulator is entirely removed. Then using a waterproof adhesive attach new insulator to frame in locations shown in Figure 4.



# SECTION 3 FRONT SUSPENSION AND FINAL DRIVE

## SECTION 3A

### FRONT SUSPENSION

**CAUTION:** *Front suspension fasteners are important attaching parts in that they could affect the performance of vital components and systems, and/or could result in major repair expense. It must be replaced with one of the same part number or with an equivalent part if replacement becomes necessary. Do not use a replacement part of lesser quality or substitute design. Torque values must be used as specified during reassembly to assure proper retention of this part.*

Contents of this section are listed below:

SUBJECT	PAGE NO.
Trouble Diagnosis .....	3A-2
Theory and Operation .....	3A-5
General Description .....	3A-8
Disc Hub Assembly .....	3A-8
Hub Bearing .....	3A-8
Disc .....	3A-9
Knuckle Seal R.H. ....	3A-11
Knuckle Seal L.H. ....	3A-12
Knuckle .....	3A-12
Upper Control Arm .....	3A-13
Upper Control Arm Bushing .....	3A-14
Lower Control Arm .....	3A-14
Lower Control Arm Bushing .....	3A-16
Ball Joint .....	3A-17
Ball Joint Checks .....	3A-17
Lower Control Arm Ball Joint .....	3A-18
Upper Control Arm Ball Joint .....	3A-18
Stabilizer Bar .....	3A-19
Shock Absorber .....	3A-19
Torsion Bar .....	3A-19
Crossmember Support .....	3A-19
Ride Height .....	3A-20
Front End Alignment .....	3A-21
Alignment Adjustment .....	3A-21
Torque Specifications .....	3A-22
Special Tools .....	3A-23

Problem	Possible Cause	Correction
Noise in Front End	<ol style="list-style-type: none"> <li>1. Ball joints and steering linkage lubrication.</li> <li>2. Shock absorber loose or bushings worn.</li> <li>3. Worn control arm bushings.</li> <li>4. Worn tie rod ends.</li> <li>5. Loose stabilizer bar.</li> <li>6. Loose wheel nuts.</li> <li>7. Loose suspension bolts.</li> </ol>	<ol style="list-style-type: none"> <li>1. Lubricate at recommended intervals.</li> <li>2. Tighten bolts and/or replace bushings.</li> <li>3. Replace bushings.</li> <li>4. Replace tie rod ends.</li> <li>5. Tighten all stabilizer bar attachments.</li> <li>6. Tighten the wheel nuts to proper torque.</li> <li>7. Torque to specifications or replace.</li> </ol>
Tire Thump	<ol style="list-style-type: none"> <li>1. Tire and wheel out of balance.</li> <li>2. Tire and wheel out of round.</li> <li>3. Blister or bump on tire.</li> <li>4. Improper shock absorber action.</li> </ol>	<ol style="list-style-type: none"> <li>1. Balance wheels.</li> <li>2. Replace tire.</li> <li>3. Replace tire.</li> <li>4. Replace shock absorber.</li> </ol>
Excessive or Uneven Tire Wear	<ol style="list-style-type: none"> <li>1. Underinflated or overinflated tires.</li> <li>2. Improper toe-in.</li> <li>3. Wheels out of balance.</li> <li>4. Hard Driving.</li> <li>5. Over loaded vehicle.</li> </ol>	<ol style="list-style-type: none"> <li>1. Inflate tire to proper recommended pressure.</li> <li>2. Adjust toe-in.</li> <li>3. Balance wheels.</li> <li>4. Instruct driver.</li> <li>5. Instruct driver.</li> </ol>
Scuffed Tires	<ol style="list-style-type: none"> <li>1. Toe-in incorrect.</li> <li>2. Excessive speed on turns.</li> <li>3. Tires improperly inflated</li> <li>4. Suspension arm bent or twisted.</li> </ol>	<ol style="list-style-type: none"> <li>1. Adjust toe-in to specifications.</li> <li>2. Advise driver.</li> <li>3. Inflate tires to proper recommended pressure.</li> <li>4. Replace arm.</li> </ol>
Cupped Tires	<ol style="list-style-type: none"> <li>1. Front shock absorbers defective.</li> <li>2. Worn ball joints.</li> <li>3. Wheel and tire out of balance.</li> <li>4. Excessive tire or wheel runout.</li> </ol>	<ol style="list-style-type: none"> <li>1. Replace shock absorbers.</li> <li>2. Replace ball joints.</li> <li>3. Balance wheel and tire.</li> <li>4. Compensate for runout.</li> </ol>

Problem	Possible Cause	Correction
Shock Absorber-Weak.	<ol style="list-style-type: none"> <li>1. Low or uneven tire pressure.</li> <li>2. Excessive or incorrect vehicle loading.</li> <li>3. Worn out shock absorber (Front).</li>   <li>4. Worn out shock absorber (Rear).</li> </ol>	<ol style="list-style-type: none"> <li>1. Inflate tires to the proper recommended pressure.</li> <li>2. Instruct driver.</li>   <li>3. Perform on vehicle test. Push down and lift up at end of bumper nearest front shock in question. right and left shocks must be comparable in rebound resistance to compression ration (usually 2 to 1). If in doubt compare with vehicle having acceptable ride quality.</li> <li>4. Disconnect the lower shock mountings. Stroke shocks at various rates of speed through maximum travel in both directions. Compare side to side for rebound and compression resistance. Rebound resistance is normally stronger than compression (approximately 2 to 1). It is mandatory that right and left shocks feel comparable. If in doubt about condition, compare wth a known good shock.</li> </ol>
Shock Absorber-Noisy.	<ol style="list-style-type: none"> <li>1. Loose mounting.</li> <li>2. Faulty shock absorber</li> </ol>	<ol style="list-style-type: none"> <li>1. Check all shock mounting torques (bolt and/or nut).</li> <li>2. Observe hoisting instructions and instructions for removal of front shock absorbers. Clamp shock upside down. Clamp vise on top mount with shock vertical in vise (do not clamp on reservoir tube). Rear shocks may be tested on the vehicle by disconnecting the lower mount. Completely extend to full rebound then exert an extra pull. If a "GIVE" is felt a loose piston is indicated and the shock should be replaced. A hissing noise (orifice swish) is normal, however, replace shock absorber for any of the following:             <ol style="list-style-type: none"> <li>a. A skip or lag at reversal near mid-stroke.</li> <li>b. A seize (except at either extreme end of travel).</li> <li>c. A noise such as a grunt or squeal after completing one full stroke in both directions.</li> <li>d. A clicking noise at fast reversal.</li> </ol> </li> </ol>

Problem	Possible Cause	Correction
Shock Absorber—Leaks.	1. Faulty shock absorber.	<p>1. A slight trace of shock fluid is NOT cause for replacement as the seal permits some seepage for lubrication of the piston rod. The shock contains a fluid reserve to compensate for seepage.</p> <p>A shock that is truly leaking is easily detected as there will be evidence of shock fluid around the seal cover and on down the reservoir tube and should be replaced.</p>

## THEORY AND OPERATION

### FRONT-END GEOMETRY

The term "FRONT-END GEOMETRY" refers to the angular relationship between the front wheels, the front suspension attaching parts and the ground. The angle of the knuckle (now called steering axis inclination) away from the vertical, the pointing in or "TOE-IN" of the front wheels, the tilt of the front wheels from vertical (when viewed from the front of the vehicle) and the tilt of the suspension members from vertical (when viewed from the side of the vehicle) - all these are involved in front-end geometry. These items have an effect on the steering ease, steering stability and riding qualities of the Motor Home

and has a direct effect on tire wear. The various factors that enter into front-end geometry are covered here each one under its own heading.

### CAMBER (FIGURE 1)

Camber is the tilting of the front wheels from the vertical. When the wheels tilt outward at the top, the camber is said to be positive (+). When the wheels tilt inward at the top, the camber is said to be negative (-). The amount of tilt is measured in degrees from the vertical and this measurement is called the camber angle.

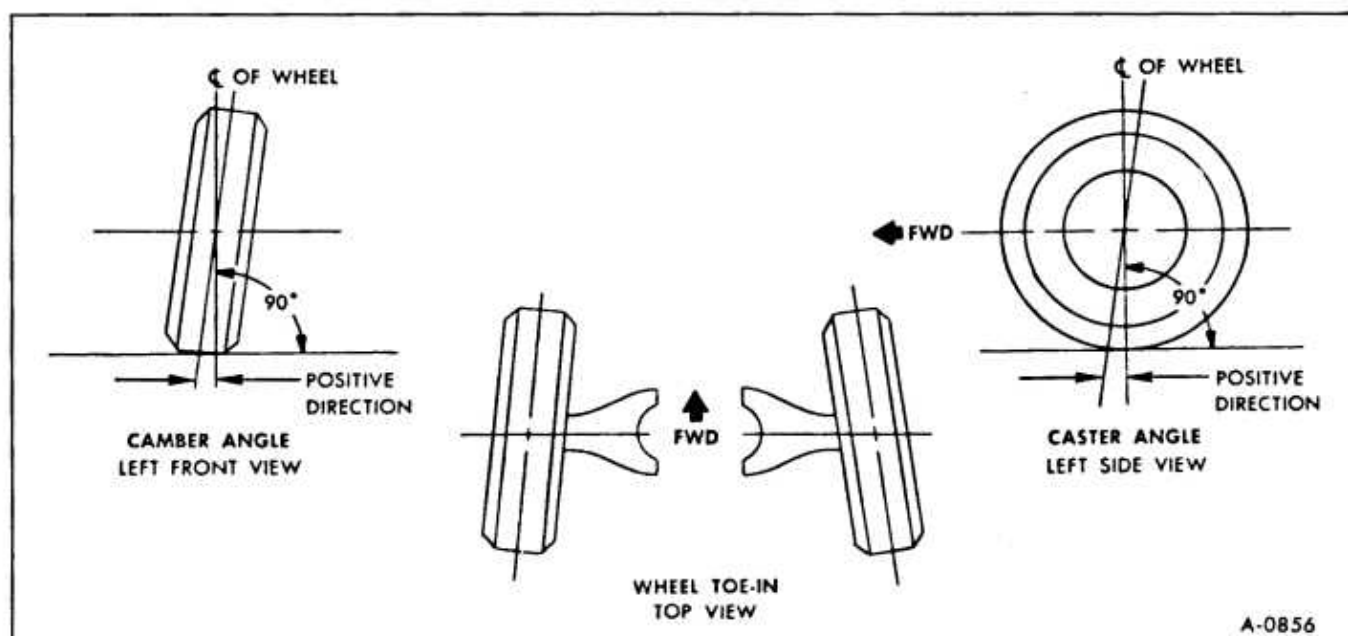

Figure 1—Caster, Camber and Toe-In

## CASTER (FIGURE 1)

Caster is the tilting of the front steering axis either forward or backward from the vertical. A backward tilt is said to be positive (+) and a forward tilt is said to be negative (-). You cannot see caster angle without special instrument, but you can understand that if you look straight down from the top of the upper control arm to the ground you would find that the ball joints do not line up (fore and aft) when a caster angle other than "0" is present. If you had a positive caster angle the lower ball joint would be slightly ahead of the upper ball joint center line. In short then: caster is the forward or backward tilt of the steering axis.

## STEERING AXIS INCLINATION (FIGURE 2)

Steering axis inclination is the inward tilt (at the top) of the steering knuckle from the vertical. The inward tilt, or inclination, of the knuckle tends to

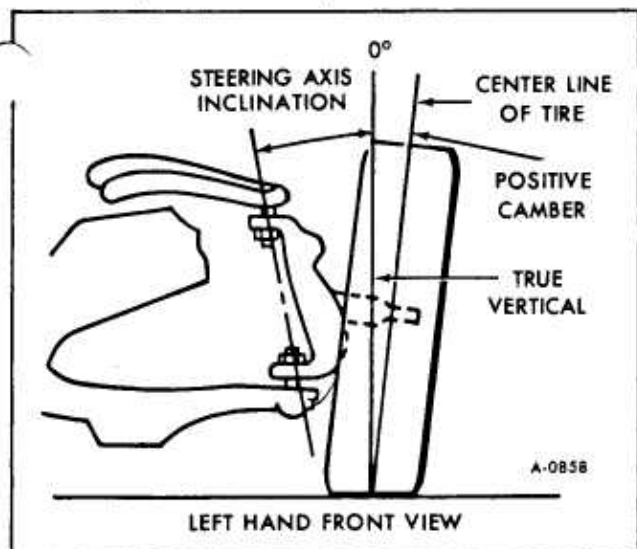

Figure 2—Steering Axis Inclination

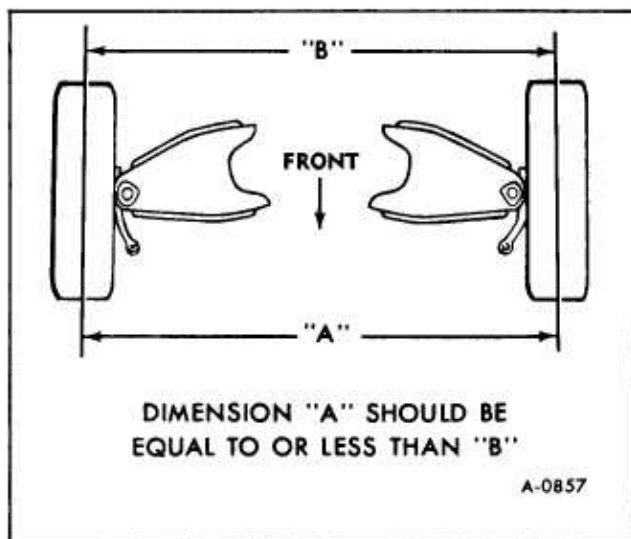
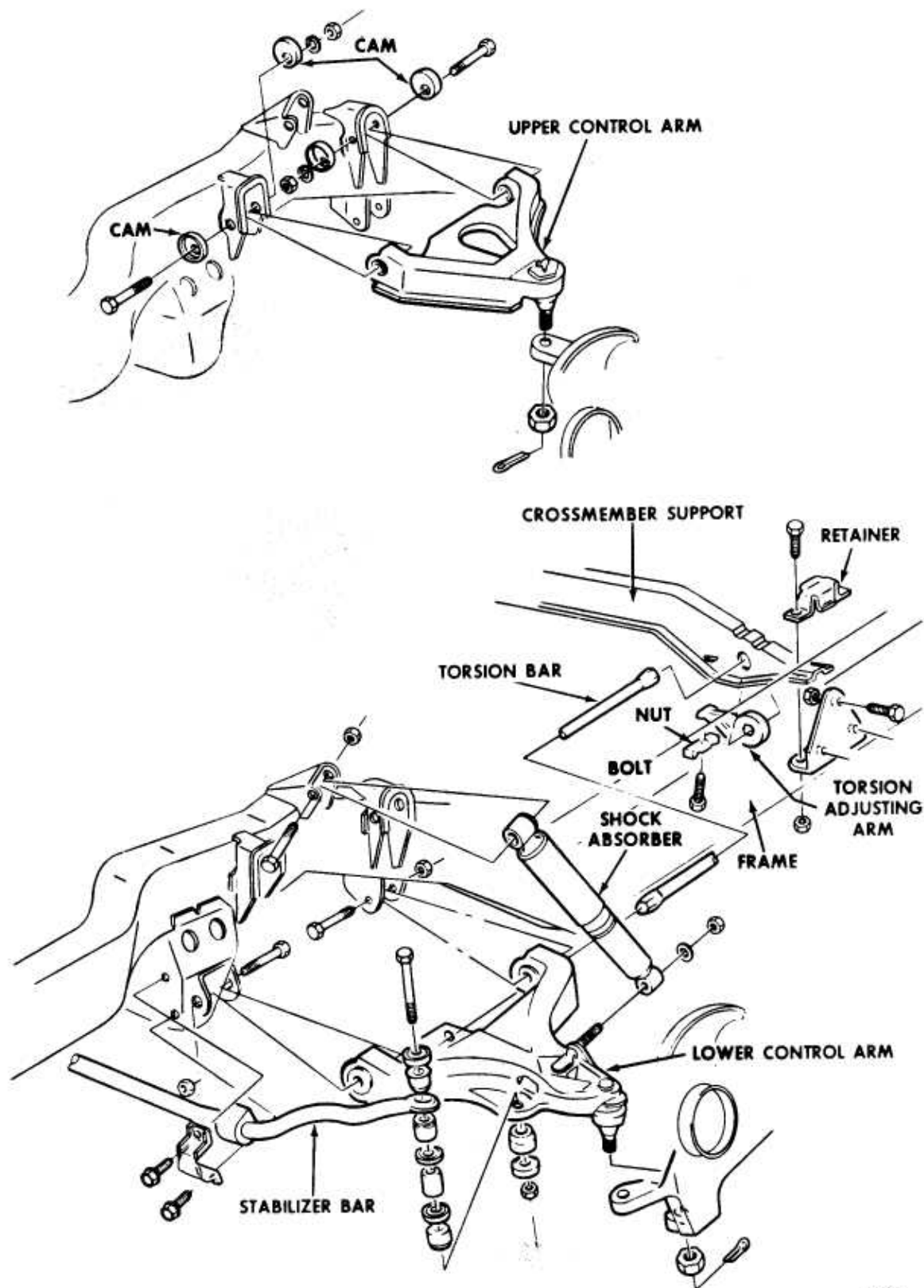

Figure 3—Toe-In

keep the wheels straight ahead. This is desirable because, it helps return the steering wheel straight ahead after a turn. This steering wheel return comes about because the vehicle is actually "LIFTED" when the wheels are swung away from the straight ahead position. Then the weight of the car tends to return the wheels straight ahead after a turn is completed.

## TOE-IN (FIGURE 3)

Toe-in is the turning in of the front wheels. The actual amount of toe-in is normally only a fraction of an inch. The purpose of toe-in is to ensure parallel rolling of the front wheels. (Excessive toe-in or toe-out will cause tire wear) Toe-in also serves to offset the small deflections of the wheel support system which occurs when the vehicle is rolling forward. In other words, even when the wheels are set to toe-in slightly when the vehicle is standing still, they tend to roll parallel on the road when the vehicle is moving.



A-0864

Figure 4-Front Suspension



## TOE-OUT ON TURNS

Toe-out on turns refers to the difference in angles between the front wheels and the vehicle frame during turns. Since the inner wheel turns a smaller radius than the outer wheel, when rounding a curve, it must be at a sharper angle with respect to the vehicle frame. That is it must toe-out more than the outside wheel toes-in. This condition is desirable because it allows the front wheels to turn in a concentric circle. Toe-out on turns is non-adjustable.

## GENERAL DESCRIPTION

The front suspension on the Motor Home consists of control arms, stabilizer bar, shock absorbers and a right and left torsion bar. Torsion bars are used instead of the conventional coil springs. The front end of the torsion bar is attached to the lower control arm. The rear of the torsion bar is mounted into an adjustable arm at the torsion bar crossmember. The carrying height of the Motor Home is controlled by this adjustment (Figure 4).

## DISC & HUB (FIGURE 6)

### REMOVAL

1. Siphon approximately two-thirds of the brake fluid from the front reservoir of the master cylinder. Discard fluid.

**NOTE:** Do not empty front reservoir or it will be necessary to bleed the brake system.

2. Hoist Motor Home and remove wheel.
3. Remove cotter pin, drive axle nut and washer.
4. Position Tool J-22269 or caliper as shown in Figure 5
5. Tighten screw of tool until caliper moves outboard far enough to push piston to bottom of piston bore. This will allow the shoes to back off from disc surface. Remove Tool J-22269.
6. Remove the two caliper to knuckle attaching bolts. (figure 12).
7. Carefully lift caliper assembly from disc and reposition so that brake hose is not kinked or stretched.
8. Loosen uniformly and remove the three bolts securing the retainer to the knuckle (figure 7).
9. Position Tool No. J-24717 on hub as shown in Figure 8.
10. Operate slide hammer Tool No. J-2619, until assembly is free of knuckle. See Figure 8.
11. Remove slide hammer and Tool No. J-24717.

### INSTALLATION

See CAUTION on Page 3A-1 of this section.

1. Lubricate O.D. of bearing with chassis grease.
2. The outer race of the bearing is a snug fit into the knuckle. Light tapping on the hubs outer surface (not the disc) will aid assembly. Care must be used when installing hub assembly over drive axle splines so that splines are in correct alignment.
3. Install three bolts attaching bearing retainer to knuckle Torque to 35 ft. lbs.
4. Install drive axle washer and nut. Torque nut to 110 ft. lbs. If necessary to align cotter pin slot, tighten nut and install NEW cotter pin and crimp. Torque not to exceed 280 ft. lbs.

**NOTE:** Do not back off nut to install cotter pin.

## HUB BEARING

### REMOVAL

1. Remove disc hub assembly. Refer DISC HUB ASSEMBLY-Removal.

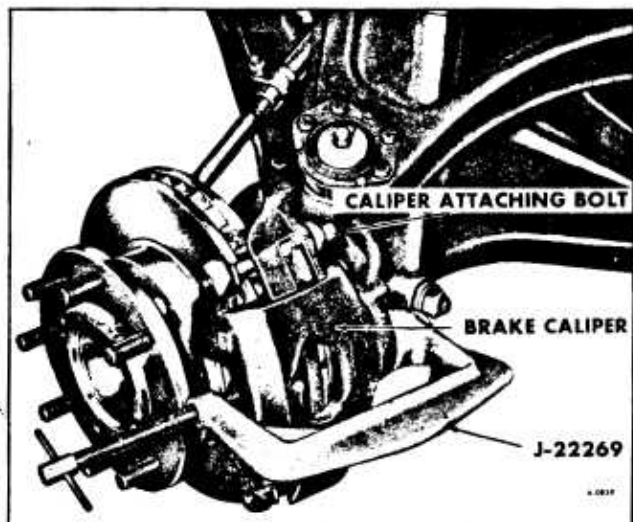

Figure 5-Caliper Removal

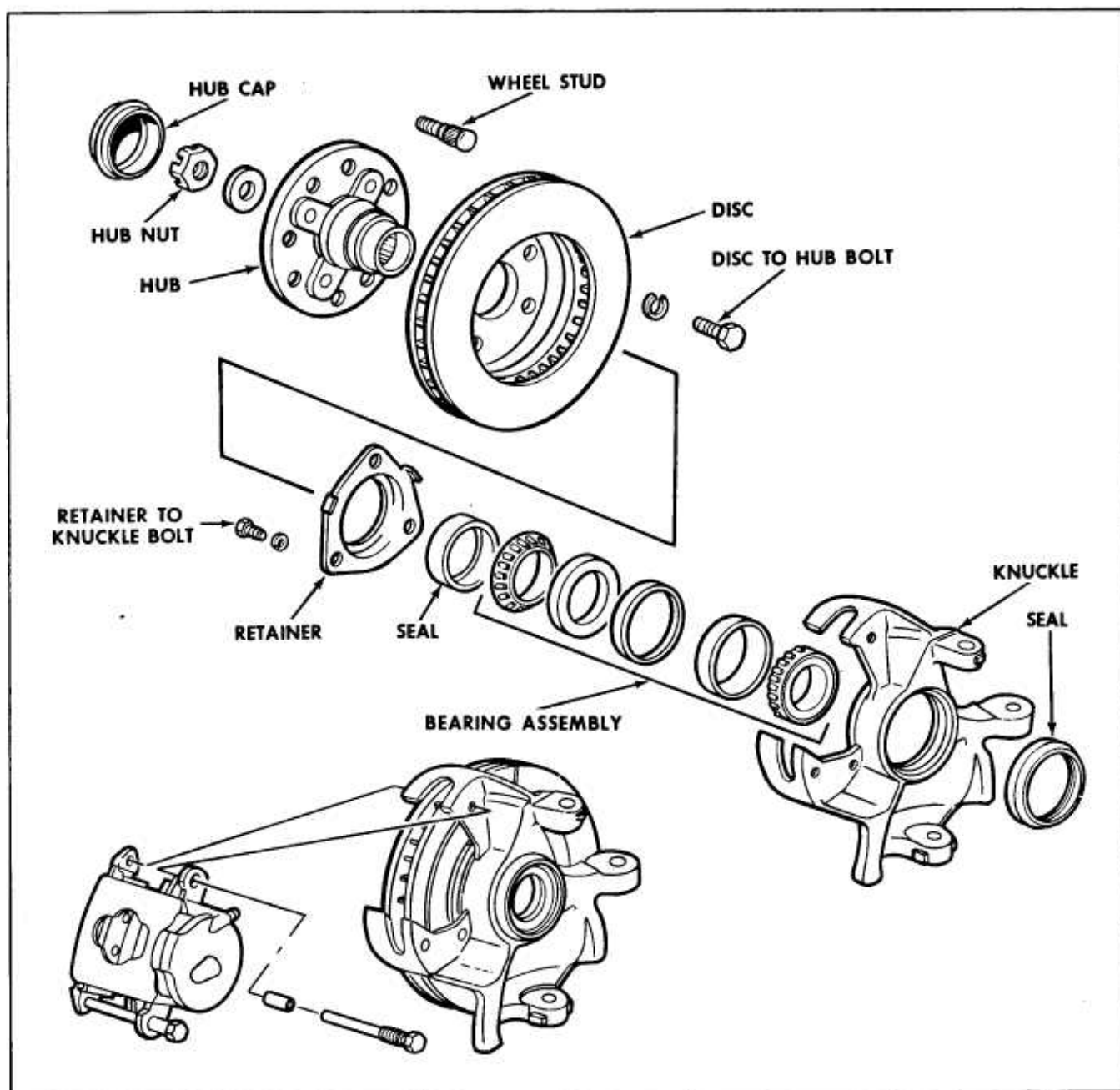

Figure 6-Disc and Hub Assembly

2. Assemble Tool No. J-23345 to Tool No. J-8433-1

3. Position tool assembly as shown in Figure 9.

4. With Tool No. J-22214-6 in place, and a clamp in position as shown in Figure 9, tighten center screw until bearing is free of hub.

5. Remove seal and retainer.

## INSTALLATION

See CAUTION on Page 3A-1 of this section.

1. Position retainer over hub.

2. Lubricate seal lips with Special Seal Lubricant No. 1050169 or equivalent then position seal over hub with metal end toward retainer.

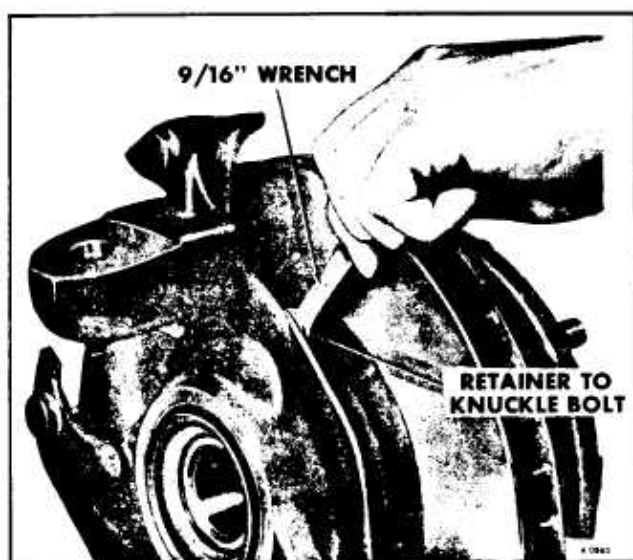

Figure 7—Retainer Bolt Removal

3. Install bearing as shown in Figure 11.

4. Install hub assembly. Refer to HUB ASSEMBLY-Installation.

## DISC

### REMOVAL (FIGURE 10)

1. Remove disc and hub assembly. Refer DISC and HUB ASSEMBLY-Removal.

2. Remove hub bearing. Refer HUB BEARING-Removal.

3. Remove (4) bolts and separate disc from hub as shown in Figure 10.

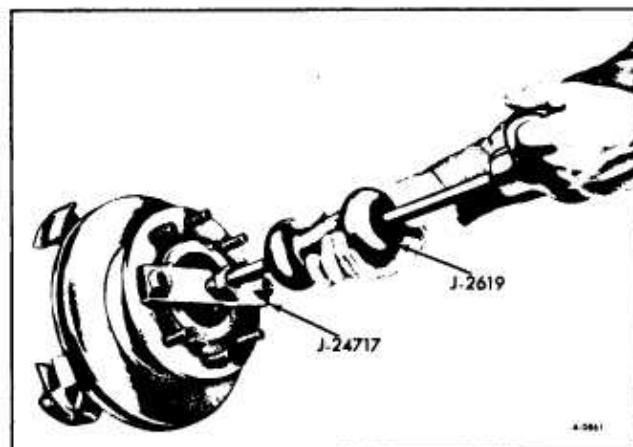

Figure 8—Hub and Disc Removal

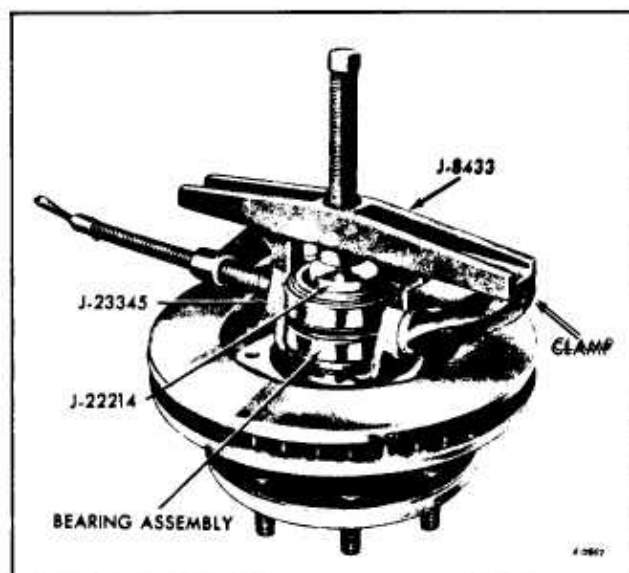

Figure 9—Bearing Removal

## INSTALLATION

1. Install (4) attaching bolts and torque to 35 ft. lbs.

2. Install hub bearing. Refer HUB BEARING-Installation.

3. Install disc and hub assembly. Refer DISC and HUB ASSEMBLY-Installation.



Figure 10—Disc Removal

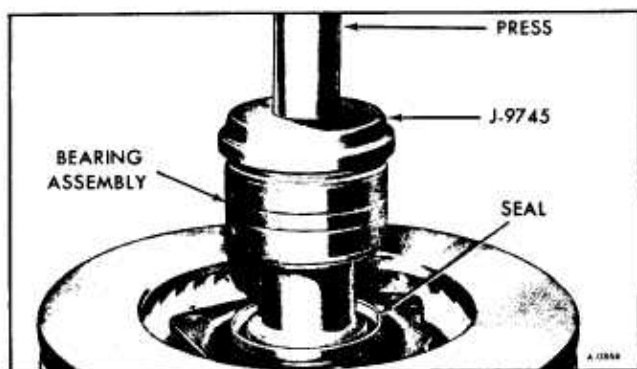

Figure 11—Installing Bearing

## KNUCKLE SEAL R.H.

### REMOVAL

1. Hoist Motor Home and place a floor stand on each side.
2. Remove drive axle cotter pin, nut and washer under the lower control arm.
3. Remove inner C.V. joint attaching bolts. Discard bolts.
4. Push inner C.V. joint outward enough to disengage from R.H. final drive output shaft and move rearward.
5. Remove R.H. output shaft support bolts to engine.
6. Remove R.H. output shaft.
7. Remove drive axle assembly.

**CAUTION:** Care must be exercised so that C.V. joints do not turn to full extremes and that seals are not damaged against shock absorber or stabilizer bar.

8. Pry seal from knuckle.

### INSTALLATION

See CAUTION on Page 3A-1 of this section.

1. Lubricate seal inner lips with Special Seal Lubricant No. 1050169 or equivalent.
2. Install Tool J-23115 into seal until metal O.D. of seal contacts tool.
3. Install seal into knuckle until tool bottoms. (figure 12).

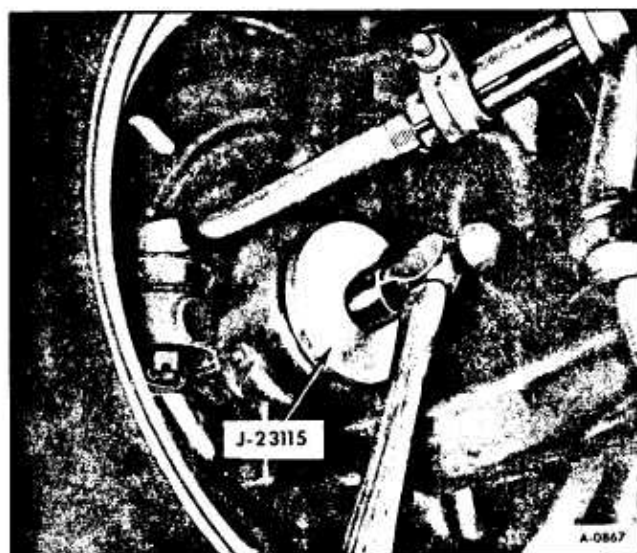

Figure 12—Installing Knuckle Seal

4. Carefully place R.H. drive axle assembly into lower control arm and enter outer race splines into knuckle.
5. Lubricate final drive output shaft seal with Special Seal Lubricant, No. 1050169 or equivalent.
6. Install R.H. output shaft into final drive and loosely attach support bolts to engine.

**NOTE:** When attaching the right hand output shaft to the engine, do not let the shaft hang. Assemble support bolts loosely, and by moving the flange end of the shaft up and down, and back and forth, find the center location. Hold the shaft in this position and then torque the bolts to 55 ft. lbs. on support.

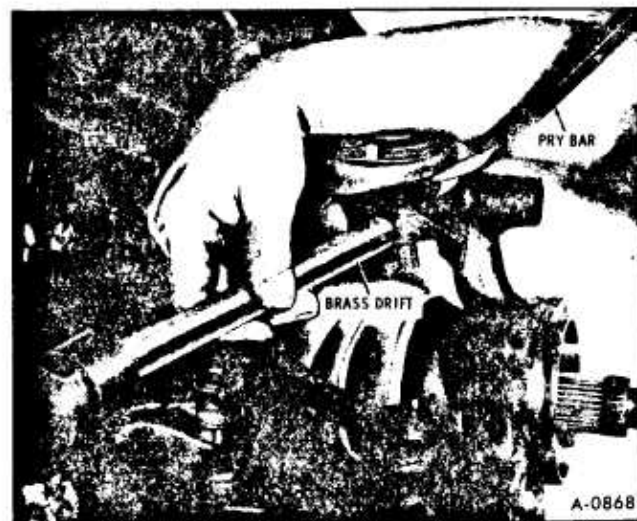

Figure 13—Removing Upper Ball Joint

7. Move R.H. drive axle assembly toward front of car and align with R.H. output shaft. Install NEW attaching bolts and torque to 65 ft. lbs.

8. Install washer and nut on drive axle. Torque to 110 ft. lbs. tighten to next slot. Insert NEW cotter pin and crimp. Torque not to exceed 280 ft. lbs.

**NOTE:** Do not back off nut to install NEW cotter pin.

9. Remove floor stands and lower hoist.

## KNUCKLE SEAL L.H.

### REMOVAL

1. Hoist Motor Home and place a floor stand on each side under the lower control arm.

2. Remove wheel.

3. Remove drive axle cotter pin, nut and washer.

4. Remove tie rod end cotter pin and nut.

5. Using Tool J-24319 remove tie rod end.

6. Remove upper control arm ball joint cotter pin and nut. Remove brake hose clip from ball joint stud.

7. Using hammer and brass drift, drive on knuckle until upper ball joint stud is free. (figure 13).

8. Using Tool J-24319 remove lower ball joint from knuckle. Care must be exercised so that ball joint doesn't damage drive axle seal.

9. Remove knuckle. Support knuckle so that brake hose is not damaged.

10. Pry seal from knuckle.

### INSTALLATION

See CAUTION on Page 3A-1 of this section.

1. Lubricate seal inner lips with Special Seal Lubricant No. 1050169 or equivalent.

2. Install Tool J-23115 into seal until metal O.D. of seal contacts tool.

3. Install seal into knuckle until tool bottoms (figure 12).

4. Insert lower control ball joint stud into knuckle and attach nut. Do not torque.

5. Center L.H. drive axle assembly into splines of hub and insert upper ball joint stud.

6. Place brake hose clip over upper ball joint stud and install nut. Do not torque.

7. Insert tie rod end stud into knuckle and attach nut. Torque to 40 ft. lbs. Install NEW cotter pin and crimp. Do not back off nut to install cotter pin.

8. Torque upper ball joint stud nut to 50 ft. lbs. min. Tighten to align cotter pin.

**CAUTION:** *Upper ball joint cotter pin must be crimped toward upper control arm to prevent interference with outer C.V. joint seal.*

9. Torque lower ball joint stud nut to 100 ft. lbs. min. Tighten to align NEW cotter pin.

10. Install drive axle washer and nut. Torque to 110 ft. lbs. tighten to next slot. Install NEW cotter pin and crimp. Torque not to exceed 280 ft. lbs.

**NOTE:** Do not back off nut to install NEW cotter pin.

11. Install wheel, remove floor stands, and lower hoist.

## KNUCKLE

### REMOVAL

1. Remove disc hub assembly (refer to DISC HUB ASSEMBLY, REMOVAL).

2. Remove upper ball joint cotter pin and nut.

3. Remove brake line hose clip from ball joint stud.

**NOTE:** Do not loosen ball joint stud.

4. Using a brass drift and hammer, Figure 13, loosen upper ball joint stud.

5. Remove cotter pin and nut from tie rod end.

6. Using Tool J-24319 remove tie rod end as shown in Figure 14.



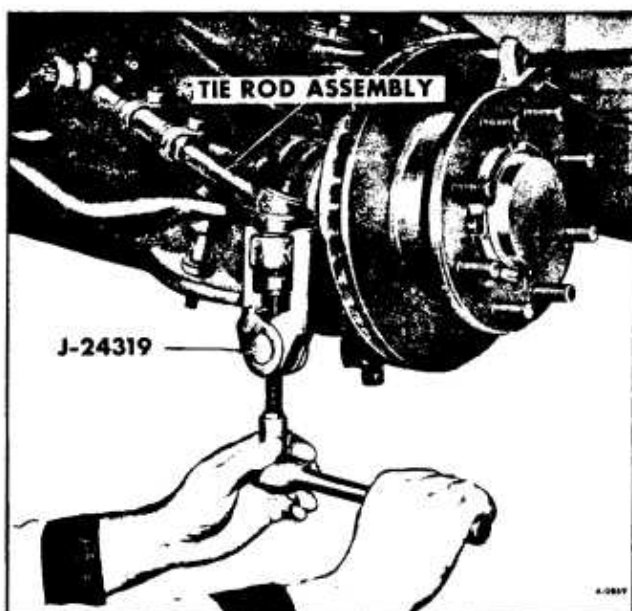

Figure 14—Removing Tie Rod End

7. Remove cotter pin and nut from lower ball joint.
8. Using Tool J-24319; remove lower ball joint from knuckle (figure 15).
9. Remove knuckle. Pry seal from knuckle.

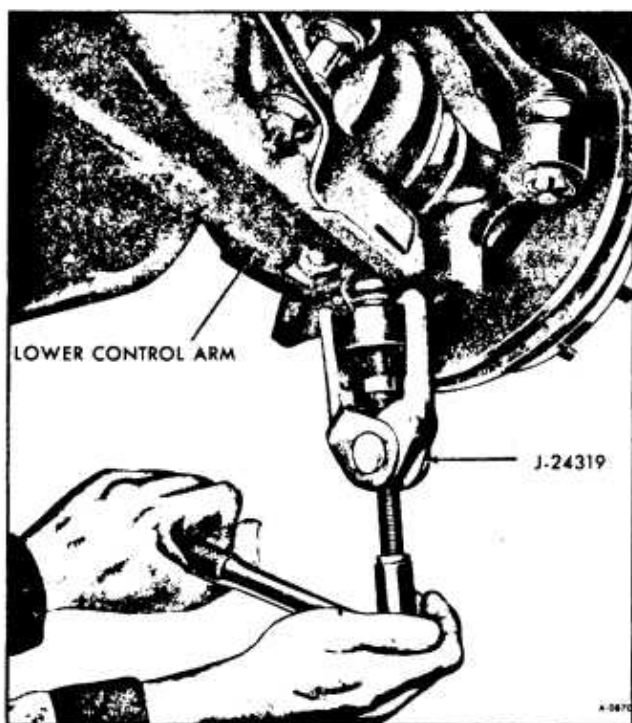

Figure 15—Removing Lower Ball Joint

## INSTALLATION

See **CAUTION** on Page 3A-1 of this section.

1. Using Tool J-23115 install seal into knuckle.
2. Install lower ball joint stud into knuckle and attach nut. Do not torque.
3. Install tie rod end stud into knuckle and attach nut. Do not torque.
4. Install upper ball joint stud into knuckle and attach brake line hose clip. Install nut.
5. Torque ball joint nut to a minimum of 50 ft. lbs. (upper), 100 ft. lbs. (lower). Tighten to install **NEW** cotter pins.

**CAUTION:** *Cotter pin on upper ball joint must be bent up only to prevent interference with C.V. joint seal.*

6. Torque tie rod end nut to 40 ft. lbs. and install **NEW** cotter pin.

**NOTE:** Do not back off nut to install **NEW** cotter pin.

7. Install disc hub assembly (refer to **DISC HUB ASSEMBLY INSTALLATION**).

## UPPER CONTROL ARM

### REMOVAL

1. Hoist Motor Home and remove wheel, and place a floor stand on each side under and firmly against the lower control arm.
2. Remove upper shock attaching bolt.
3. Remove cotter pin and nut from upper ball joint.
4. Disconnect brake hose clamp from ball joint stud.
5. Using hammer and a drift, Figure 13, drive on spindle until upper ball joint stud is disengaged.
6. Remove upper control arm cam assemblies and remove control arm from Motor Home by guiding shock absorber through access hole in arm.

## INSTALLATION

See **CAUTION** on Page 3A-1 of this section.

**NOTE:** Service upper control arm assemblies have plugs instead of grease fittings in ball joints. Remove plugs and install grease fittings before installing control arm.

1. Guide upper control arm over shock absorber and install bushing ends into frame bracket.
2. Install cam assemblies as shown in Figure 4.
3. Install ball joint stud into knuckle.
4. Install brake hose clip on ball joint stud.
5. Install ball joint nut. Torque to 50 ft. lbs. Insert **NEW** cotter pin and crimp.

**NOTE:** Do not back off nut to install **NEW** cotter pin.

**CAUTION:** *Cotter pin must be crimped toward upper control arm to prevent interference with outer C.V. joint seal.*

6. Install upper shock attaching bolt and nut. Torque nut to 90 ft. lbs.
7. Install wheel and remove floor stands.
8. Lower hoist.
9. Check camber, caster and toe-in and adjust if necessary. Refer to **FRONT END ALIGNMENT**.

## UPPER CONTROL ARM BUSHING (ON MOTOR HOME)

Upper control arm bushings can be removed and installed on or off the Motor Home.

### REMOVAL

1. Hoist vehicle, place floor stands under and firmly against the lower control arm, and remove wheel.
2. Disconnect upper shock absorber attaching bolt. (figure 18)
3. Remove cam assemblies from control arm.
4. Move control arm out of frame brackets and attach bushing removal tools as shown in Figure 19.

## INSTALLATION

See **CAUTION** on Page 3A-1 of this section.

1. Install Tools as shown in Figure 20 and press bushings into control arm.
2. Move control arm into frame brackets and install cam assemblies. The cams are installed with the bolts in the lower position. Torque nut to 110 ft. lbs.
3. Connect upper shock attaching bolt. Torque nut to 90 ft. lbs.
4. Replace wheel, remove floor stands, lower hoist.
5. Align front wheels. Refer to **FRONT END ALIGNMENT**.

## LOWER CONTROL ARM

### REMOVAL

1. Hoist Motor Home and remove wheel assembly.
2. Before using Tool J-22517, remove two nuts and center screw, then place tool over crossmember support. Align pin of tool into hole in crossmember. Install two nuts on tool and center screw: Turn center screw until seated in dimple of torsion adjusting arm. (figure 16)
3. Using a socket on the torsion bar adjusting bolt, turn counterclockwise, counting the number of turns necessary to remove.

**NOTE:** The number of turns to remove the adjusting bolt will be used when installing, to obtain the original carrying height.

4. Remove adjusting bolt and nut.
5. Turn center screw of Tool J-27517 until torsion bar is completely relaxed and remove torsion bar noting which end is front.
6. Disconnect shock absorber and stabilizer link from lower control arm.
7. Remove drive axle nut.
8. Remove cotter pin and nut from lower ball joint stud.

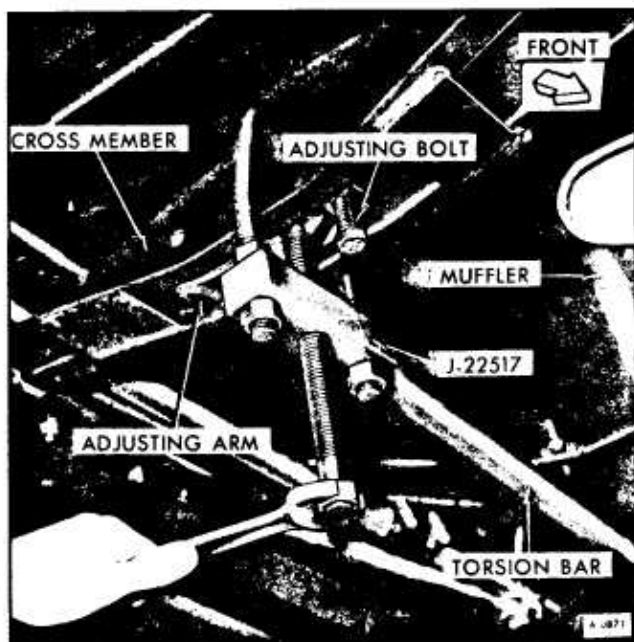

Figure 16—Removing Torsion Bar

9. Install Tool J-24319 and remove ball joint stud from knuckle. (figure 15)

10. Remove bolts from lower control arm to frame and remove torsion bar.

11. Push inboard on drive axle and pull outward on knuckle to gain clearance, then remove lower control arm from knuckle.

## INSTALLATION

See CAUTION on Page 3A-1 of this section.

1. Install lower control arm making certain shock absorber is guided onto lower control arm shock absorber mount. Guide ball joint stud into knuckle. Install but do not torque stud nut.

2. Install lower control arm to frame bracket bolts. Install nuts and torque to 90 ft.-lbs.

3. Torque lower ball joint stud to 100 ft. lbs.

**NOTE:** Do not back off nut to install NEW cotter pin.

4. Install shock absorber nut and torque to 90 ft. lbs. Install stabilizer link and torque nut to 15 ft. lbs.

5. Apply a liberal amount of chassis grease to both ends and place front end of torsion bar into

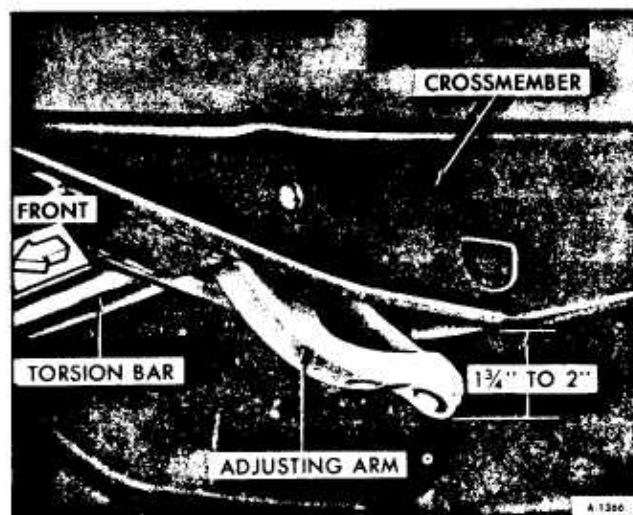

Figure 17—Positioning of Adjusting Arm

control arm. Push torsion bar all the way forward into the control arm.

6. Insert adjusting arm into the crossmember and position to 1-3/4" - 2" below the centerline of the crossmember (see figure 17). Slide torsion bar rearward until it is flush with the rear face of the adjusting arm.

7. Reposition Tool J-22517 making sure pin of tool is in hole in crossmember. Turn center screw of Tool J-22517 until adjusting arm is in position to allow installation of the adjusting nut.

8. Apply a liberal amount of chassis grease and install adjusting bolt and turn number of turns previously recorded to obtain original ride height.

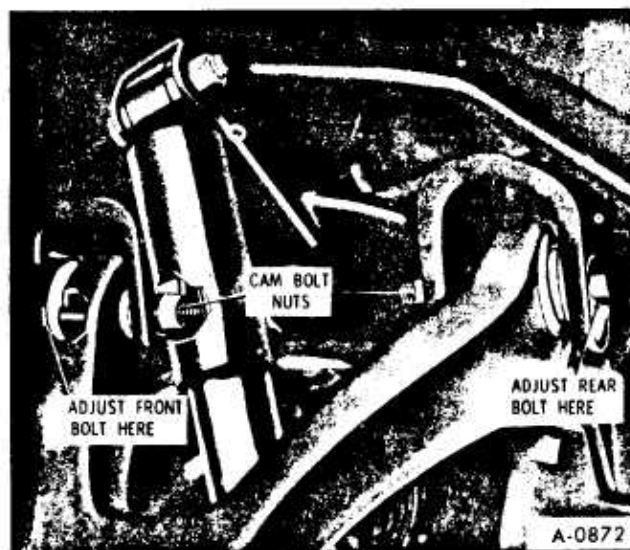

Figure 18—Upper Control Arm Attachment



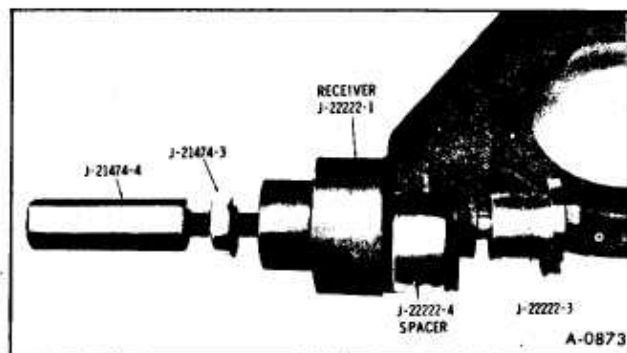

Figure 19—Removing Upper Control Arm Bushing

9. Turn center screw until torsion is relaxed and remove tool.

10. Lower Motor Home.

11. Check ride height (see figure 31) Adjust if necessary refer to "RIDE HEIGHT" in this section.

## LOWER CONTROL ARM BUSHING REMOVAL

1. Hoist Motor Home.

2. Remove stabilizer link bolt. Discard bolt.

3. Place floor stands under frame horn, and under points where frame sections are bolted. Lower front lift to floor.

4. Install Tool J-22517. Method for attaching, refer to TORSION BAR REMOVAL, Item 2 through 6.

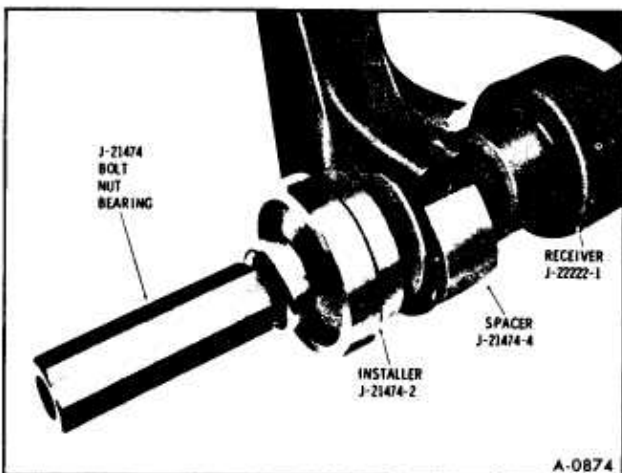

Figure 20—Installing Upper Control Arm Bushing

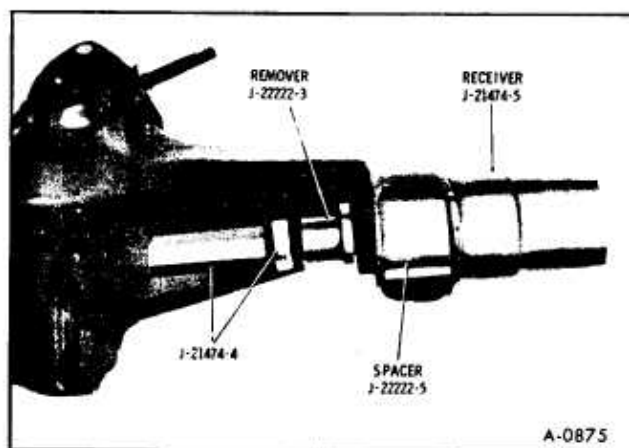

Figure 21—Removing Lower Control Arm Rear Bushing

5. Remove lower control arm bushing bolts and pull control arm down until free of frame brackets.

6. Install Tools through rear bushing and press out bushing as shown in Figure 21.

**NOTE:** Due to the torsion bar anchor attachment to the lower control arm, it will be necessary to use a hardened 1/2" x 20 nut as shown in Figure 22 to remove the front bushing.

## INSTALLATION

See CAUTION on Page 3A-1 of this section.

1. Install Tools as shown in Figure 24 and press rear bushing into lower control arm.

**NOTE:** Due to the torsion bar anchor attachment to the lower control arm, it will be necessary to use a hardened 1/2" x 20 nut as shown in Figure 23 to install the front bushing.

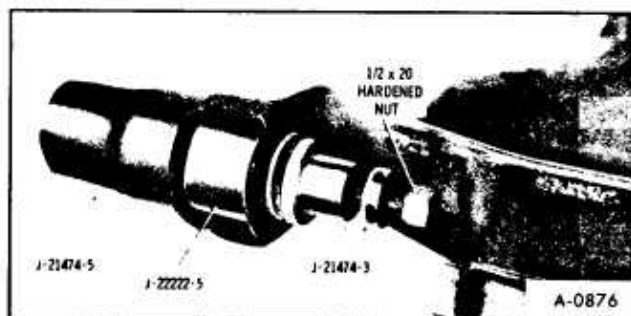

Figure 22—Removing Lower Control Arm Front Bushing

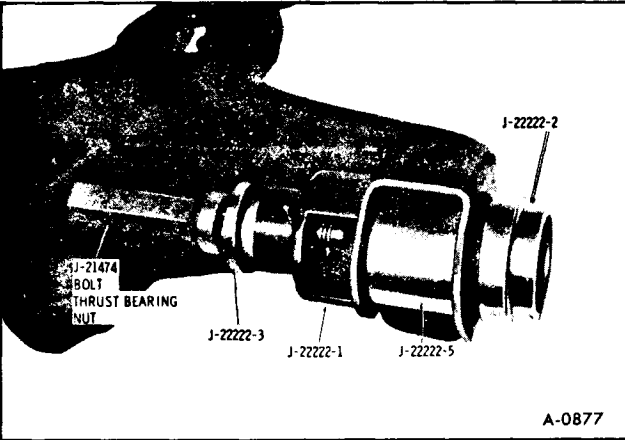

Figure 23—Installing Lower Control Arm Front Bushing

2. Raise lower control arm into frame brackets and install bushing bolts and nut. Do not torque.
3. Using Tool J-22517 Refer to TORSION BAR INSTALLATION, Item 10 through 13.
4. Raise front lift and remove floor stands.
5. Using a new bolt attach stabilizer link bolt to lower control arm. Torque nut to 15 ft. lbs. Cut bolt off 1/4" below nut.
7. Lower and torque lower control arm bushing nuts to 90 ft. lbs.

### BALL JOINT

Ball joint lubrication and seal inspection is important, refer to Section 0 for specifications and maintenance intervals.

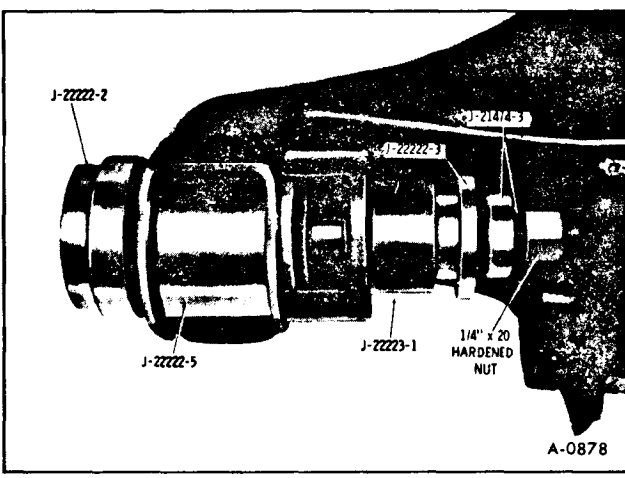

Figure 24—Installing Lower Control Arm Rear Bushing

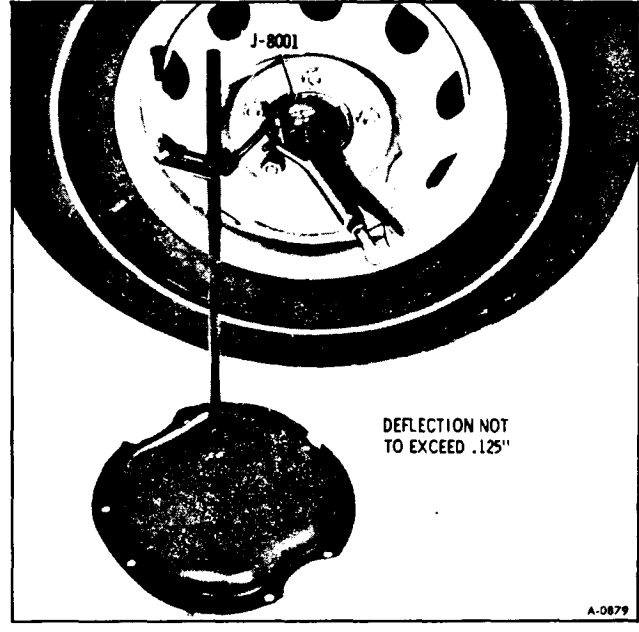

Figure 25—Ball Joint Vertical Check

### BALL JOINT CHECKS

#### VERTICAL CHECKS

1. Raise the Motor Home and position floor

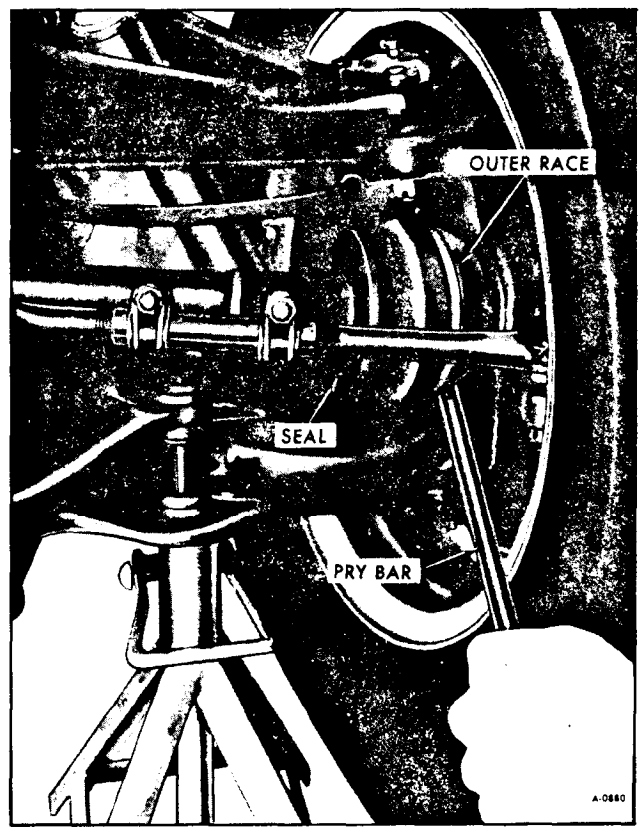

Figure 26—Pry Bar Installation

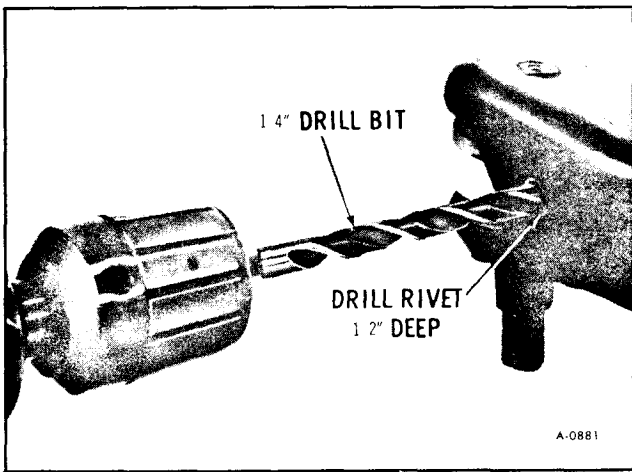

Figure 27-Drilling Ball Joint Rivets

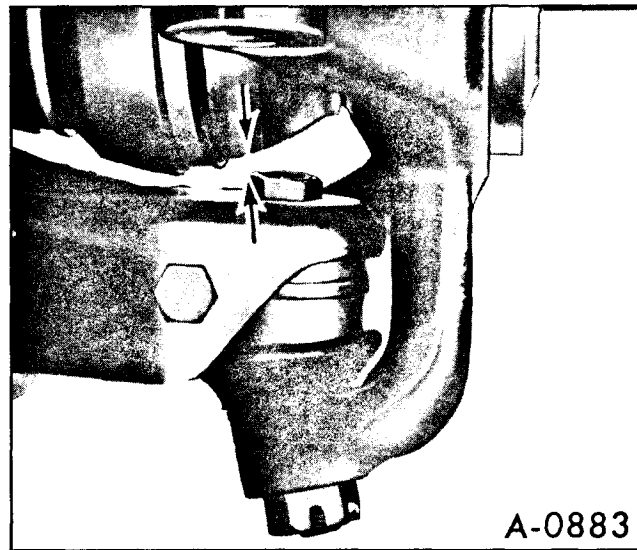

Figure 29-Checking Clearance

stands under the left and right lower control arms as near as possible to each lower ball joint. Motor Home must be stable and should not rock on the floor stands. Lower front hoist.

2. Position dial indicator as shown in Figure 25.

3. Place a pry bar as shown in Figure 26 and pry down on bar. Care must be used so that drive axle seal is not damaged. Reading must not exceed .125"

## LOWER CONTROL ARM BALL JOINT

### REMOVAL

1. Remove knuckle. Refer to **KNUCKLE REMOVAL**.

2. Drill side rivets 1/2" deep using 1/4" (figure

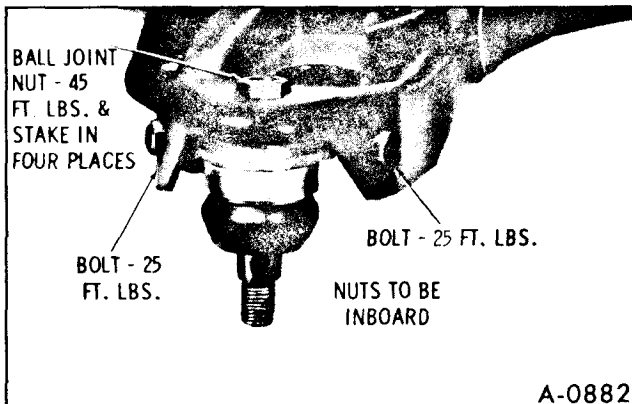

Figure 28-Installing Service Ball Joints

27) drill bit. Drill same rivets again with 1/2" drill bit just deep enough to remove head of rivet.

3. Drive out rivets with hammer and punch.

4. Drill center rivet using 5/8" drill bit just deep enough to remove rivet head.

5. Using hammer and punch, drive center rivet of joint until joint is out of control arm.

### INSTALLATION

See **CAUTION** on Page 3A-1 of this section.

1. Install service ball joint into control arm and torque bolts and nut as shown in Figure 28.

2. Install knuckle - Refer to **KNUCKLE INSTALLATION**.

3. Check clearance from ball joint nut to drive axle outer joint as shown in Figure 29. If no clearance is obtained, it may be necessary to grind off nut but not more than 1/16".

## UPPER CONTROL ARM BALL JOINT

### REMOVAL

1. Hoist Motor Home under lower control arms and remove wheel.

2. Remove cotter pin and nut from upper ball joint stud.

3. Disconnect brake hose clip from upper ball joint stud.

4. Using hammer and a brass drift similar to Figure 13 drive on spindle until upper ball joint stud is disengaged from spindle.

5. Raise control arm up and drill rivets with a 1/8" drill bit 3/8" deep.

**NOTE:** It may be necessary to use a block of wood between frame and control arm for support.

6. Drill off rivets using a 1/2" drill bit. Do not drill into control arm.

7. Using a punch, drive out rivets and remove ball joint.

## INSTALLATION

See **CAUTION** on Page 3A-1 of this section.

1. Install service ball joint into control arm (bolts must be installed from top side). Torque nuts to 20 ft. lbs.

2. Install ball joint stud into knuckle and position brake hose clip over stud.

3. Install ball joint stud nut and torque to 50 ft. lbs. Tighten to install **NEW** cotter pin.

**CAUTION:** *Cotter pin must be bent up to prevent interference with outer C.V. Joint Seal.*

4. Install wheel and lower hoist.

## STABILIZER BAR

### REMOVAL

1. Remove link bolts, nuts, grommets, spacers and retainers from lower control arm. Discard bolts.

2. Remove two bolts attaching dust shield to frame (both sides).

3. Remove bracket to frame attaching bolts and remove stabilizer bar from front of car.

## INSTALLATION

See **CAUTION** on Page 3A-1 of this section.

Reverse removal procedure.

**NOTE:** New link nuts are torqued to 15 ft. lbs. then bolt is cut off 1/4" below nut.

## SHOCK ABSORBER (FIGURE 4)

### REMOVAL

1. Raise Motor Home and place a safety stand under and firmly against the lower control arm.

**CAUTION:** *This must be done to prevent the lower control arm from shifting and damaging the tie rod.*

2. Remove wheel.

3. Remove upper shock attaching bolt.

4. Remove lower shock attaching nut and carefully guide shock through upper control arm.

### INSTALLATION

1. Guide shock absorber through upper control arm and onto lower shock mounting stud.

2. Extend shock towards upper mount as necessary and install bolt. Torque to 90 ft. lbs.

3. Install lower shock mounting nut and torque to 90 lbs.

4. Install wheel and replace wheel nuts finger tight.

5. Remove safety stands and lower Motor Home. Torque wheel nuts 280 ft. lbs.

## TORSION BAR AND/OR CROSSMEMBER SUPPORT

### REMOVAL

1. Raise Motor Home on a twin post hoist.

2. Remove two nuts and center screw from Tool J-22517. Position tool over crossmember installing

pin of tool into hole in crossmember. Install two nuts on tool, install center screw. Grease center screw threads and the rounded end of the screw with chassis grease.

3. Turn center screw until seated in dimple of torsion bar adjusting arm. See Figure 16.

4. Remove torsion bar adjusting bolt and nut. Count the number of turns necessary to remove and record.

**NOTE:** The number of turns to remove the adjusting bolt will be used when installing to obtain the original carrying height.

5. Turn center screw of Tool J-22517 until torsion bar is completely relaxed.

6. Remove Tool J-22517.

7. Repeat steps 2, 3, 4, 5 and 6 on opposite torsion bar.

8. Remove bolts and retainer from torsion bar crossmember at frame (figure 4).

9. Disconnect exhaust pipe hanger from crossmember and loosen pipe saddle and "U" clamp. Slide hanger backward.

10. Move crossmember rearward until torsion bars are free and adjusting arms are removed.

11. Move torsion bar crossmember sideways to the extreme left. Move crossmembers upward and outward until opposite end clears exhaust pipe.

12. Remove torsion bars. Mark accordingly to insure proper installation end for end and right and left.

5. Insert torsion bar adjusting arm into crossmember, position so the arm will engage the torsion bar and the end of the arm will be 1-3/4"-2" below the crossmember (see figure 17). Tap crossmember forward enough to engage bar into arm.

6. Repeat step 5 for the other side of vehicle.

7. Position crossmember to its normal position. Torsion bars should be through and flush with rear face of the adjusting arm. If not repeat steps 5 and 6 after pulling torsion bar slightly out from the lower control arm.

8. Install retainer over each insulator and torque nut to 10 ft. lbs.

9. Reposition and connect exhaust pipe hanger to crossmember and tighten saddle and "U" clamp. Torque nuts 15 ft. lbs.

10. Position Tool J-22517 over crossmember installing pin of tool into hole in crossmember. Install two nuts on tool, install center screw.

11. Turn center screw until adjusting arm is in a position to allow installation of adjusting nut. See Figure 16.

12. Install nut and turn adjusting bolt the recorded number of turns to obtain previous ride height.

13. Turn center screw until torsion is completely relaxed. Remove tool and repeat step 10, 11, 12, 13 on the opposite side.

14. Lower hoist.

15. If ride height requires adjustment refer to "RIDE HEIGHT" following this procedure.

## INSTALLATION

1. Install torsion bars. New torsion bars are stamped on one end with an "R" for right or an "L" for left side. Apply a liberal amount of chassis grease to both ends.

2. Install crossmember insulators on the crossmembers.

3. Install crossmember and position approximately 2 inches rearward of its normal position.

4. Raise torsion bars and align with hole in crossmember. Move crossmember forward so torsion bars rests on edge of hole.

## RIDE HEIGHT

When checking front ride height, the Motor Home parked on a known level surface, and tire pressure at specified psi.

**NOTE:** For details on adjusting rear ride height refer to Section 4, REAR SUSPENSION. If vehicle is equipped with the optional Power Level System, be sure power level control knobs are set in the "TRAVEL" position prior to adjusting front ride height.

Measurements must be taken from the oval hole in the frame rail to the floor (figure 31). **NOTE:** Never attempt to increase the ride height of the Motor Home using the adjusting bolt (figure 30) while

## FRONT END ALIGNMENT

The Motor Home must be on a level surface, and tires both front and rear inflated to 60 psi.

1. Check the ride height dimension (figure 31). If not within specifications refer to "RIDE HEIGHTS" in this section.

2. Using available wheel alignment equipment CHECK caster, camber and toe-in settings. Specifications are:

	Check	Set
Caster .....	+2° to +3°	+3°
Camber-L.H. ....	+1/2° to 1°	+3/4°
Camber-R.H. ....	+1/4° to 1°	+1/2°
Toe-In .....	-1/8" to +1/8"	0

Make adjustments as required. Refer to "ALIGNMENT ADJUSTMENT" below.

## ALIGNMENT ADJUSTMENT

## Camber

1. Loosen nuts on inboard side of upper control arm cam bolts. (Figure 4).

2. Turn front cam bolt (inboard or outboard) to correct for 1/2 of incorrect setting found in checking.

3. Turn rear cam bolt (same way front bolt was turned) to correct for remaining 1/2 of incorrect setting found in checking.

Example:

Camber Reading (Checking).....	+1 1/4°
Amount To Be Corrected .....	1/2°
1/2 of 1/2° = 1/4° Front Cam Bolt	

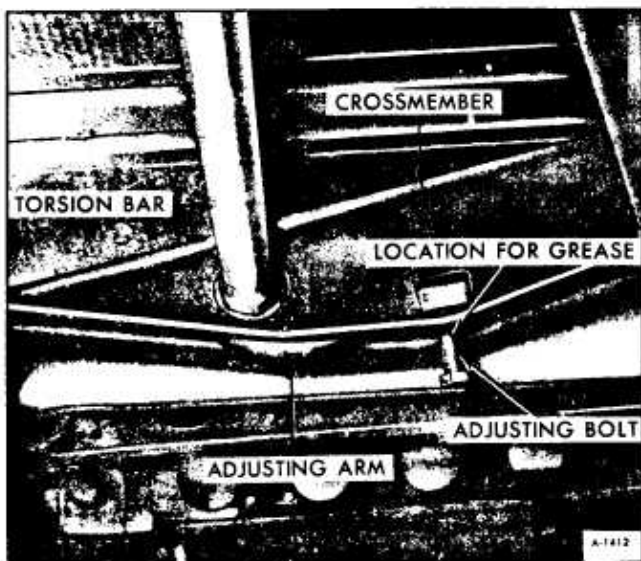

Figure 30—Location For Front Ride Height Adjustment

the vehicle is on the ground. The bolt will turn but will strip threads and will necessitate replacement of the bolt.

The procedure to adjust the ride height is as follows:

1. Raise vehicle.

2. To raise the ride height.

a. Clean off adjusting bolt with a wire brush. Apply chassis grease to threads. NOTE: Failure to use lubricant will strip the threads on the bolt.

b. Turn bolt clockwise.

c. Lower vehicle, check height, turn bolt counter-clockwise to lower if required.

3. To lower the vehicle.

a. Turn adjusting bolt counter-clockwise as required to obtain proper ride height.

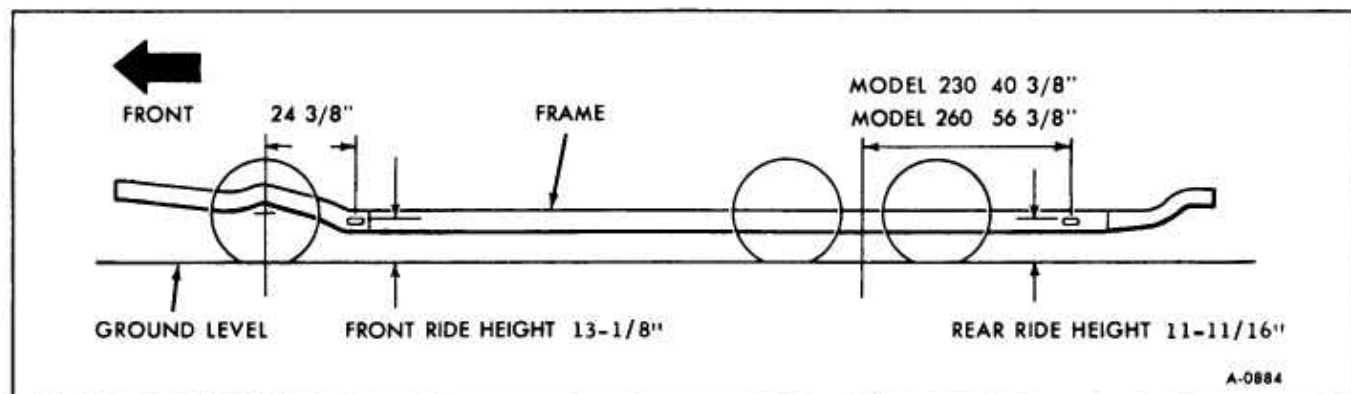

Figure 31—Motor Home Ride Height



### Remaining 1/4° Rear Cam Bolt

4. Tighten front and rear cam nuts while holding bolts with back-up wrench so that camber is not changed. Check caster, do not reset unless caster exceeds specifications.

### Caster

1. Loosen front and rear cam nuts while holding bolts with back-up wrench so that camber is not changed.

2. Turn front cam bolt so that camber changes 1/4 of the desired amount of caster to be corrected.

#### Example:

Caster Reading (Checking) ..... +5°  
 Amount To Be Corrected ..... 2°  
 1/4 of 2° = 1/2° Front Cam Bolt

3. Turn rear cam bolt so that camber now returns to corrected setting.

4. Recheck caster setting.

This is a location to start from and a correct setting can be obtained with the above procedure.

**NOTE:** Torque upper control arm cam nuts to 110 ft. lbs. Hold head of bolt securely, any movement of the cam will effect the final setting and caster camber adjustment must be rechecked.

### Toe-In Adjustment (Figure 32)

1. Loosen the clamp bolts at each end of the steering tie rod adjustable sleeves. Tie rod assembly must be decreased in length in order to increase toe-in.

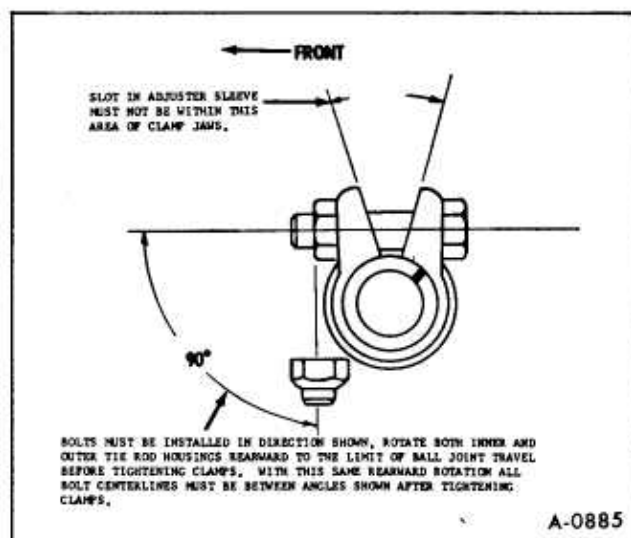

Figure 32-Positioning Tie Rod Clamp

**NOTE:** Tie rod adjuster components often become rusted in service. In such cases, it is recommended that if the torque required to remove the nut from the bolt (after breakaway) exceeds 7 ft. lbs., discard the nuts and bolts. Apply penetrating oil between the clamp and tube and rotate the clamps until they move freely. Install new bolts and nuts to assure proper clamping at the specified nut torque.

2. With steering wheel set in straight ahead position, turn tie rod adjusting sleeves to obtain the proper toe-in adjustment at curb load.

3. When adjustment has been completed according to the recommended specifications, check to see that the number of threads showing on each end of sleeve are equal and that the tie rod end housings are at right angles to steering arm. Position inner and outer tie rod clamps as shown in Figure 32. Torque nuts to 20 ft. lbs.

## TORQUE SPECIFICATIONS

APPLICATION	FT. LBS.
Drive axle Nut (Nut must be tightened to insert cotter pin) .....	110
Hub to Disc Bolts .....	35
Stabilizer Link Nut .....	15
Stabilizer Bracket to Frame Screw .....	25
Torsion Bar Crossmember Retainer Bolts .....	10
Shock Absorber	
Upper Nut .....	90
Lower-Nut .....	90
Lower Control Arm Bushing Nuts .....	90
Upper Control Arm Bushing Nuts.....	110
Ball Joint - Upper (Nut must be tightened to insert cotter pin) .....	50
Ball Joint - Lower (Nut must be tightened to insert cotter pin) .....	100
Tie Rod to Knuckle Nut (Nut must be tightened to insert cotter pin).....	40
Inner C.V. Joint to Output Shaft Bolts .....	65
Bearing Retainer to Knuckle Bolts .....	35

**SPECIAL TOOLS**

J-2619	Slide Hammer
J-8433-1	Bearing Puller
J-9745	Front Hub Bearing Installer
J-21474-3-4-5	Control Arm Bushing Remover and Installer
J-22214-4-6	Front Hub Bearing Screw and Adapter
J-23345	Front Hub Bearing Puller
J-22269	Brake Caliper Collapser
J-22517	Torsion Bar Unloader
J-23115	Front Hub Seal Installer
J-24319	Pitman Arm, Idler Arm, Ball Joint Puller
J-24717	Front Hub Puller



## SECTION 3B

# DRIVE AXLES

**CAUTION:** *The drive axle fasteners are an important attaching part in that they could affect the performance of vital components and systems, and/or could result in major repair expense. They must be replaced with one of the same part number or with an equivalent part if replacement becomes necessary. Do not use a replacement part of lesser quality or substitute design. Torque values must be used as specified during reassembly to assure proper retention of this part.*

Contents of this section are listed below:

SUBJECT	PAGE NO.
Trouble Diagnosis .....	3B-1
General Description.....	3B-2
Drive Axle Assembly (Right Hand).....	3B-2
Drive Axle Assembly (Left Hand).....	3B-3
Constant Velocity Joint.....	3B-5
Torque Specifications.....	3B-12
Special Tools .....	3B-12

## TROUBLE DIAGNOSIS

Problem	Possible Cause	Correction
Clicking noise in turns.	Excessive wear or broken outboard joint.	Inspect and replace outboard joint if necessary.
Coast to drive "CLUNK".	Loose inboard joint flange bolts.	Tighten to specified torque.
Shudder or vibration on acceleration.	Excessive wear on inboard joint housing. Worn spider assembly.	Check for brinelling of housing bores and replace if necessary. Check for wear or free rotation of balls on spider. Replace joint assembly if necessary.
Shimmy vibration at highway speeds.	Tires out of balance or out of round.	Balance front wheels or true for out of round.

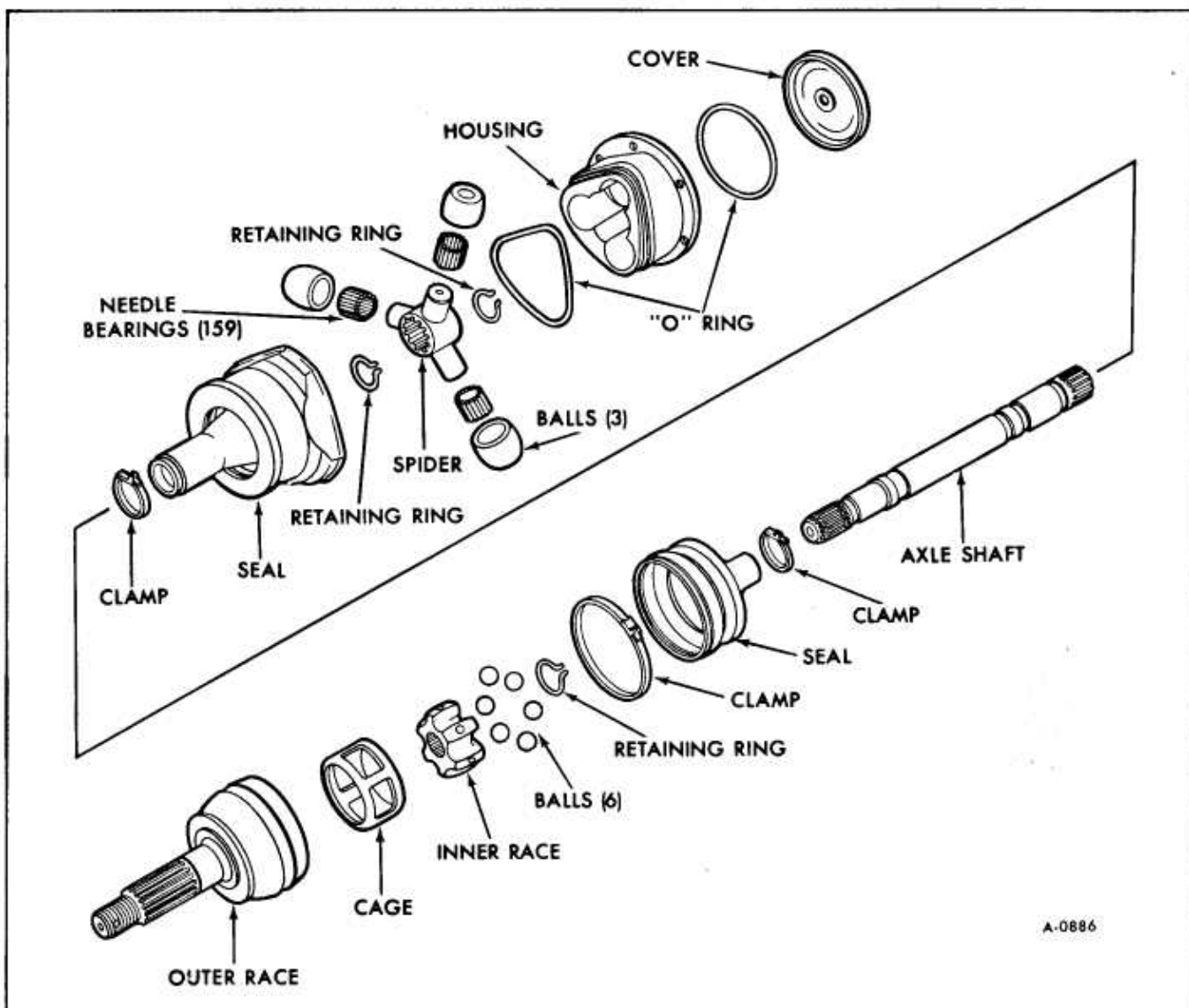

Figure 1-Drive Axle Assembly

## GENERAL DESCRIPTION

Drive axles on the Motor Home are a complete flexible assembly and consist of an axle shaft and an inner and outer constant velocity joint. (figure 1) The inner constant velocity joint has complete flexibility plus inward and outward movement. The outer constant velocity joint has complete flexibility only.

**CAUTION:** Whenever any operations call for disconnecting, connecting, removal or installation of the drive axles, care must be exercised to prevent damage to constant velocity joint seals. Seals may be wrapped with floor mat rubber or old innertube, etc.

*Make sure any rubber protective covers that are used are removed before vehicle is started or driven.*

## DRIVE AXLE ASSEMBLY (RIGHT HAND)

### REMOVAL

1. Hoist Motor Home under lower control arms.
2. Remove drive axle cotter pin, nut and washer. (figure 2)

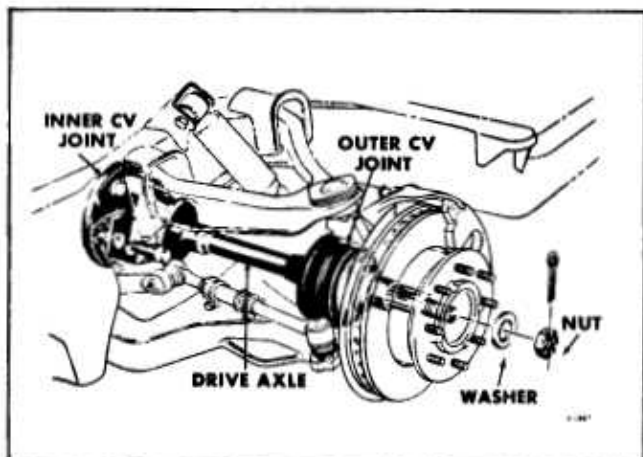

Figure 2—Drive Axle Installed

3. Remove inner C.V. joint attaching bolts. (figure 3)

4. Push inner C.V. joint outward enough to disengage from R.H. final drive output shaft and move rearward.

5. Remove R.H. output shaft support bolts to engine and final drive. (figure 2).

6. Remove R.H. output shaft.

7. Remove drive axle assembly.

**CAUTION:** Care must be exercised so that C.V. joints do not turn to full extremes and that seals are not damaged against shock absorber or stabilizer bar.

## INSTALLATION

See CAUTION on Page 3B-1 of this section.

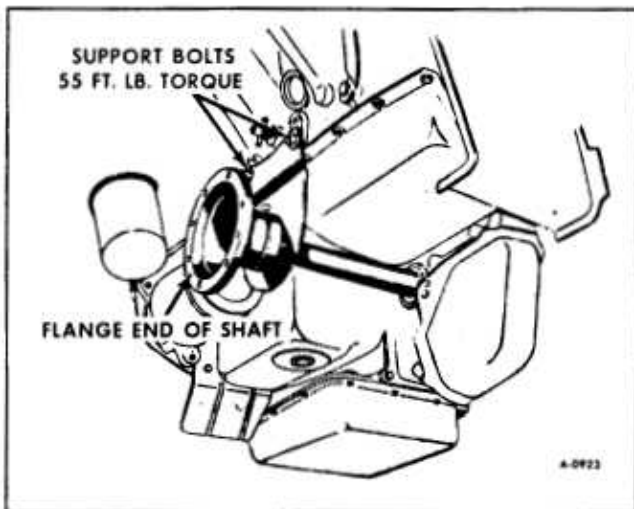

Figure 3—Aligning R.H. Output Shaft

1. Carefully place R.H. drive axle assembly into lower control arm and enter outer race splines into knuckle.

2. Lubricate final drive output shaft seal with Special Seal Lubricant, No. 1050169 or equivalent.

3. Install R.H. output shaft into final drive and attach support bolts to engine.

**IMPORTANT:** When attaching the right hand output shaft to the engine bracket, do not let the shaft hang. Referring to Figure 3, assemble bracket bolts loosely, and by moving the flange end of the shaft up and down, and back and forth, find the center location. Hold the shaft in this position and then torque the bolts to 55 ft. lbs. on support.

4. Move R.H. drive axle assembly toward front of car and align with R.H. output shaft. Install NEW attaching bolts and torque to 65 ft. lbs.

5. Install washer and nut on drive axle. Torque to 110 ft. lbs. Insert cotter pin and crimp. Tighten nut to insert cotter pin.

6. Lower hoist.

## DRIVE AXLE ASSEMBLY (LEFT HAND)

### REMOVAL

1. Hoist Motor Home under lower control arms.

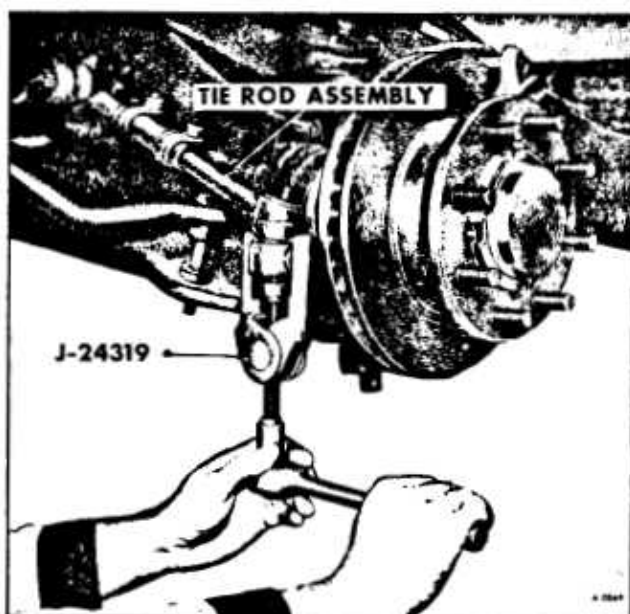

Figure 4—Removing Tie-Rod End

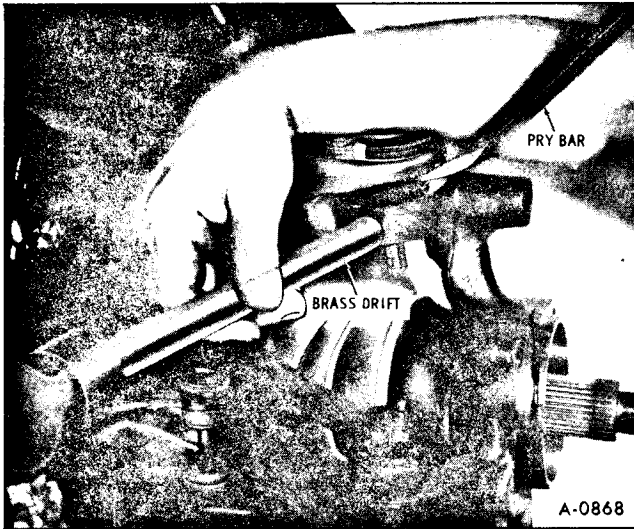

Figure 5—Removing Upper Ball Joint

2. Remove wheel.
3. Remove drive axle cotter pin, nut and washer.
4. Remove tie rod end cotter pin and nut.
5. Using Tool J-24319 as shown in Figure 4, remove tie rod end from spindle.
6. Remove bolts from drive axle assembly to left output shaft.
7. Remove upper control arm ball joint cotter pin and nut. Remove brake hose clip from ball joint stud.
8. Using hammer and brass drift, drive on knuckle until upper ball joint stud is free. (figure 5)
9. Using Tool J-24319 (figure 6) remove lower ball joint from knuckle. Care must be exercised so that ball joint doesn't damage drive axle seal.
10. Remove knuckle. Support knuckle so that brake hose is not damaged.
11. Carefully guide drive axle assembly outboard.

**CAUTION:** Care must be exercised so that C.V. joints do not turn to full extremes and that seals are not damaged against shock absorber or stabilizer bar.

## INSTALLATION

See CAUTION on Page 1 of this section.

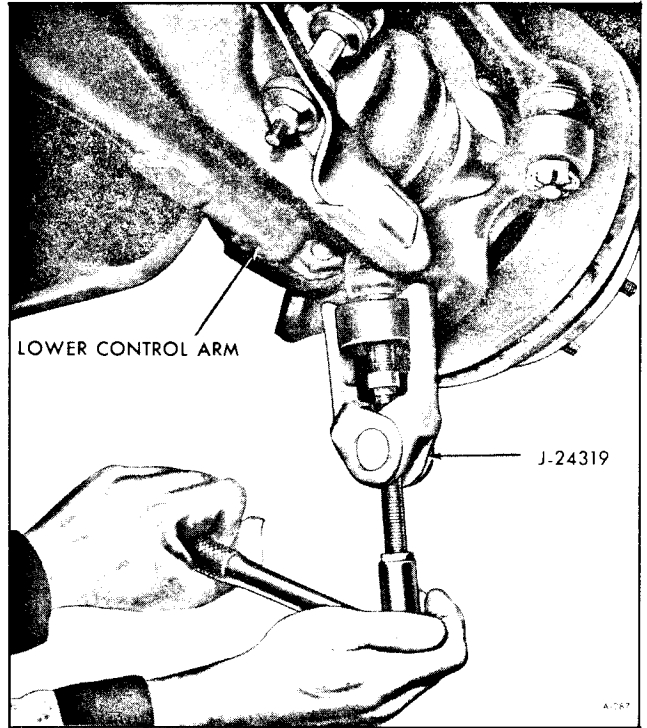

Figure 6—Removing Lower Ball Joint

1. Carefully guide L.H. Drive axle assembly onto lower control arm.
2. Insert lower control ball joint stud into knuckle and attach nut. Do not torque.
3. Center L.H. drive axle assembly in opening of knuckle and insert upper ball joint stud.
4. Place brake hose clip over upper ball joint stud and install nut. Do not torque.
5. Insert tie rod end stud into knuckle and attach nut. Torque to 40 ft. lbs. Install cotter pin and crimp. Tighten nut to install cotter pin.
6. Align inner C.V. joint with output shaft and install NEW attaching bolts. Torque to 65 ft. lbs.
7. Torque upper and lower ball joint stud nuts to 50 ft. lbs. (upper); 100 ft. lbs. (lower). Tighten nut to install cotter pins.

**CAUTION:** Upper ball joint cotter pin must be crimped toward upper control arm to prevent interference with outer C.V. joint seal.

8. Install drive axle washer and nut. Torque to 110 ft. lbs. Install cotter pin and crimp. Tighten nut, if necessary to install cotter pin.

9. Install wheel.
10. Remove floor stands and lower hoist.

## CONSTANT VELOCITY JOINT (C.V. JOINT OUT OF VEHICLE)

The C.V. joints are to be replaced as a unit and are only disassembled for repacking and replacement of damaged seals.

### DISASSEMBLY (OUTER C.V. JOINT)

1. Refer to "DRIVE AXLE ASSEMBLY (LEFT HAND) OR (RIGHT HAND)."

2. Insert axle assembly in vise. Clamp on mid-portion of axle shaft.

**NOTE:** Protect against jaw marks, do not over-clamp.

3. Remove inner and outer seal clamps. (figure 7)

4. Slide seal down axle shaft to gain access to C.V. joint.

**NOTE:** Seal may need to be rolled back or cut away on R.H. drive axle.

5. Using Tool J-5586, spread retaining ring until C.V. joint can be removed from axle spline. (figure 8)

6. Remove retaining ring (figure 15).

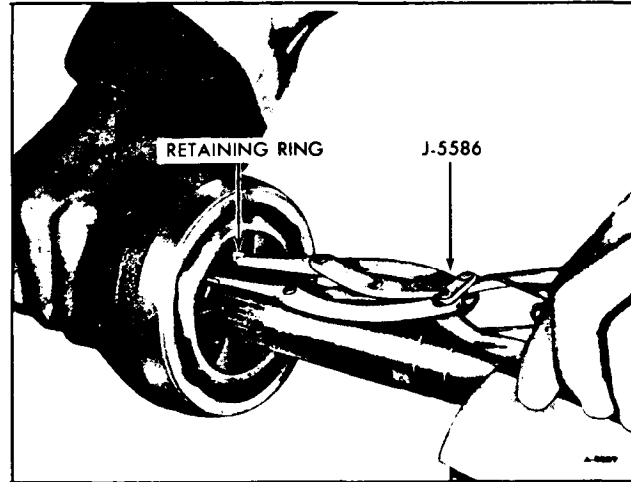

Figure 8—Removing Retaining Ring

7. Slide seal from axle shaft and discard.

8. Remove excess grease from C.V. joint.

9. Insert C.V. joint in vise, clamping on shank.

**NOTE:** Use jaw blocks to prevent damage to the joint shank.

10. Carefully place a brass drift against one of the lobes of the inner race and tap gently as shown in Figure 9. Tip the race far enough to remove the first ball. The rest of the balls should be removed one at a time, with the cage tipped as shown in Figure 10. It may be necessary to carefully pry the last ball out of the cage with a screwdriver.

11. Turn cage 90° and with slot in cage aligned with land in outer race lift out inner race and cage. (figure 11)

12. While holding cage and inner race, turn inner race 90°. Line up short land of inner race with slot

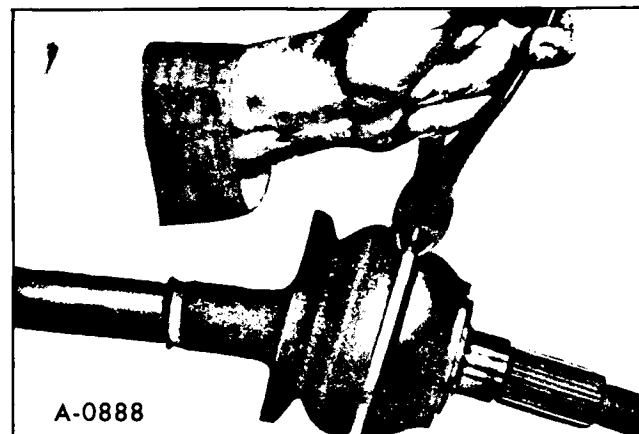

Figure 7—Cutting Seal Clamp

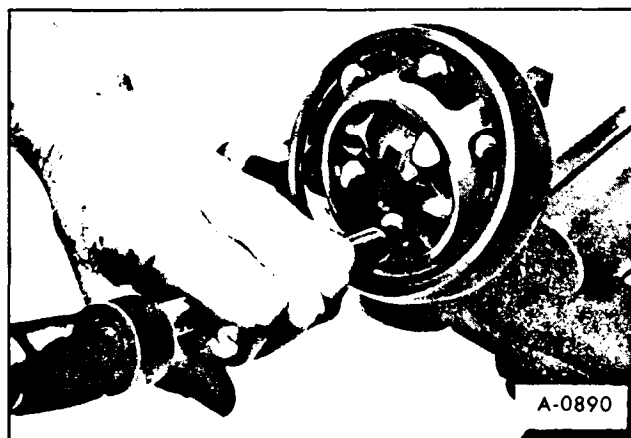

Figure 9—Tapping on Inner Race

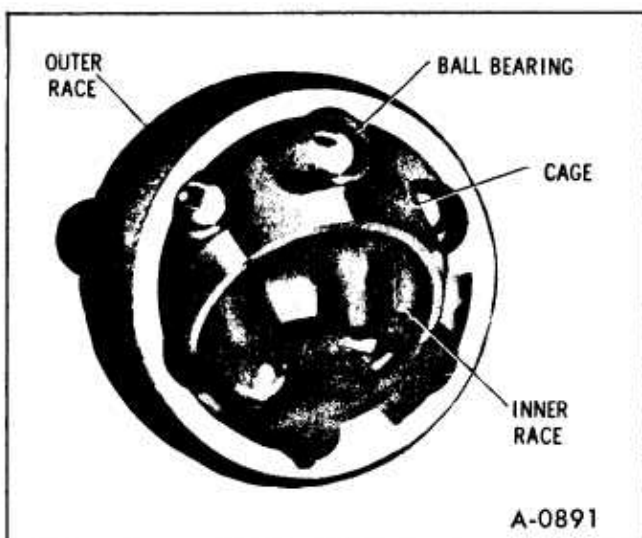

Figure 10—Removing Ball Bearings

in cage. Move short land through cage and turn inner race up and out of cage. (figure 12)

## CLEANING AND INSPECTION (OUTER)

Wash all metallic parts thoroughly in a cleaning solvent. Dry with compressed air. Rubber seal must be replaced whenever C.V. joint is disassembled for service.

**NOTE:** Outer and inner race may show a definite polished area where the balls travel. The C.V. joint should not be replaced for this reason. However, if this wear pattern is suspected to be the cause of a noisy or vibrating C.V. joint, the joint should be replaced.

1. Inspect outer race for excessive wear or scoring in the ball grooves. Inspect shaft splines and threads for any damage.

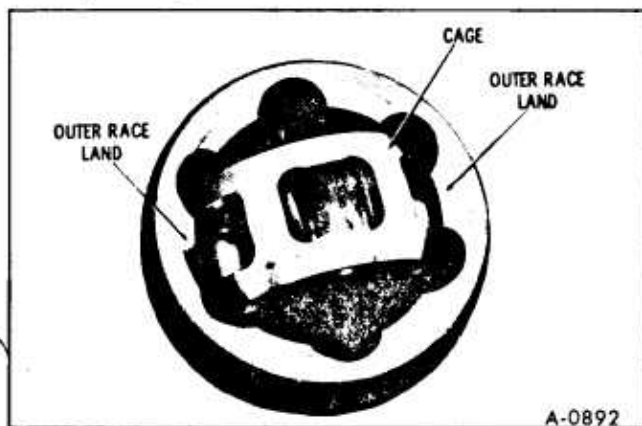

Figure 11—Positioning Cage

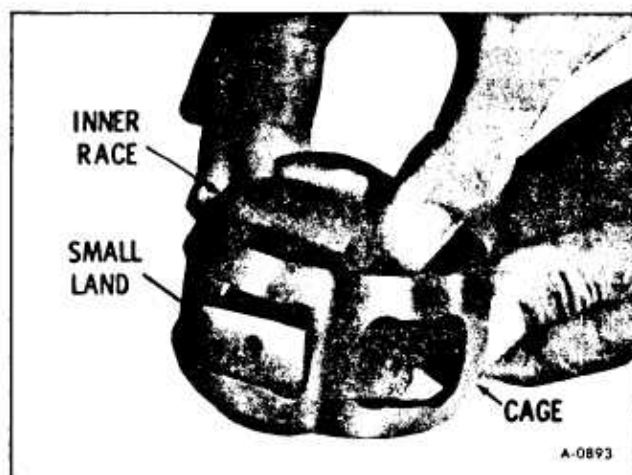

Figure 12—Removing or Installing Inner Race from Cage

2. Inspect balls (six) for nicks, cracks, breaks or scores.

**NOTE:** Slight scuffing or nicking is considered normal.

3. Inspect cage for cracks, breaks or excessive brinelling of the window flats. Some wear and slight brinelling from ball contact is normal.

4. Inspect inner race for excessive wear, scores or breaks.

5. Inspect retaining ring for being broken.

**NOTE:** If any of the above defects, except Item 5 are found, the C.V. joint assembly will have to be replaced as a unit. Retaining ring may be replaced separately.

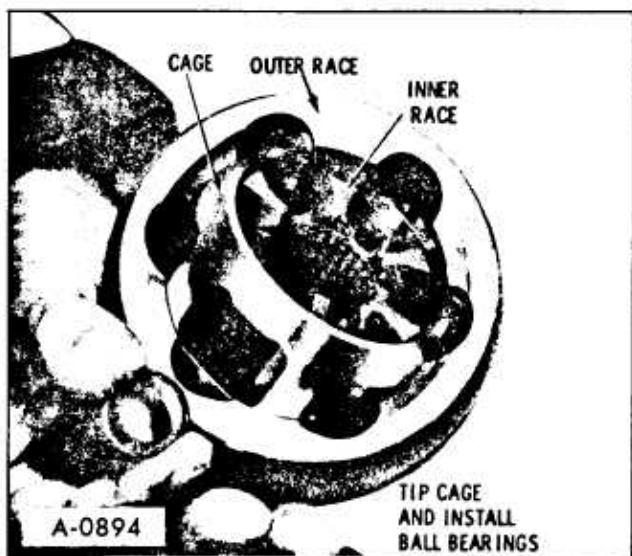

Figure 13—Installing Balls in Outer Race



## ASSEMBLY

1. Insert short land of inner race through bore of cage and pivot to install in cage. (figure 12)

2. Insert outer race in vise, clamping on shank. Protect shank from damage. Do not tighten too tight.

3. Insert cage and inner race into outer race by aligning windows on cage with lands on outer race. (figure 11) Pivot cage and inner race 90°, being certain that step on cage bore is positioned to inside of joint and snap ring groove in inner race is facing outside. (figure 13)

4. Insert balls into outer race one at a time by rocking assembly to each subsequent ball groove until all six balls are installed. (figure 13)

**NOTE:** If a brass drift is used to install the sixth ball, make certain metallic chips from drift do not enter assembly.

5. Pack C.V. joint full of Lubricant No. 1050802 or equivalent.

6. Pack inside of seal with Lubricant No. 1050802 or equivalent until folds of seal are full.

7. Place service clamp on axle shaft. Two wraps of band are required.

8. Install seal onto axle shaft.

9. Install retaining ring into inner race with tangs protruding into relieved area. (figure 16)

10. Insert axle shaft into splines of outer C.V. joint until retaining ring secures shaft in second snap ring groove.

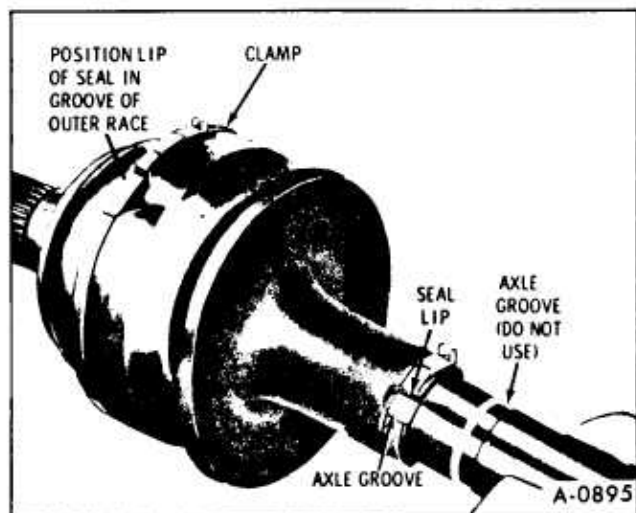

Figure 14—Positioning Seal

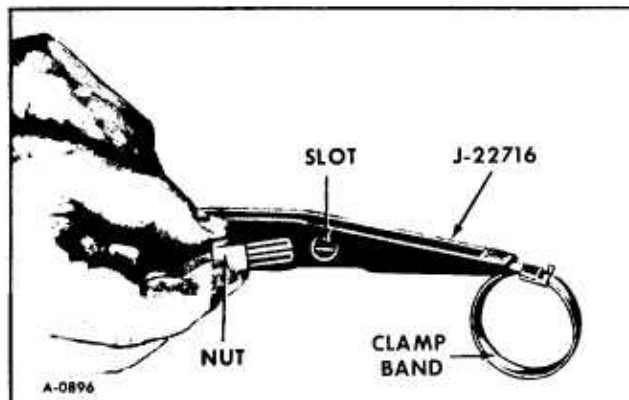

Figure 15—Assembly of J-22716 to Band

11. Position seal in groove of outer race. (figure 14)

12. Position small end of seal in nearest joint groove on axle shaft. (figure 14)

**NOTE:** After seal is in position on axle shaft make sure no lubricant is in grooves of seal before installing seal clamp band.

13. With service clamps over seals in correct position, follow procedures listed below and using Figures 15–19.

a. Pull clamp to desired size and insert band into Tool J-22716. Then insert nut into tool with band in slot of nut as shown in Figure 15.

b. Loop seal clamp band around seal end twice with strap passing through its own retainer each time a loop is completed.

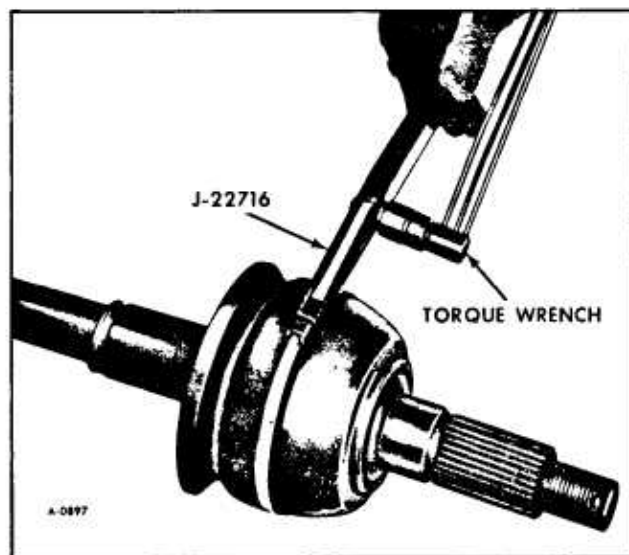

Figure 16—Tightening Band

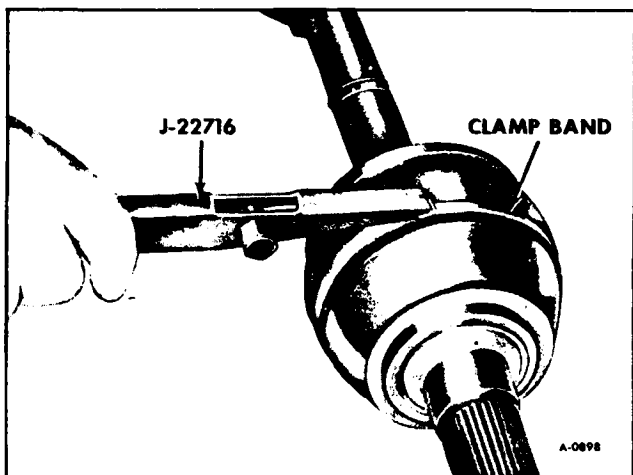

Figure 17—Bending Band Over Lock Tangs

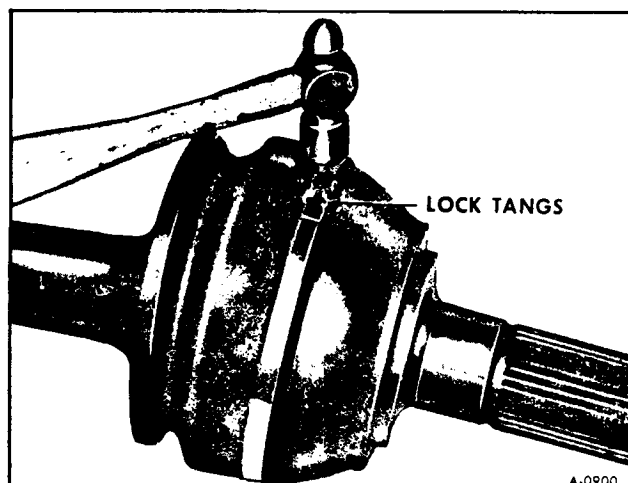

Figure 19—Bending Lock Tangs

c. After completion of second loop, feed extra length of strap into small end of Seal Clamp Band Installer, J-22716.

**NOTE:** Be sure to have the open side of the tool facing up.

d. Slide bolt through holes in side of tool and at the same time, secure strap in slot in the nut.

e. Lift end of strap up and out of the open side of tool.

f. Place a wrench on nut and draw band up tight, then torque nut to 65 in. lbs. (see figure 16) After desired torque is obtained, turn tool over to bend band over lock tangs of clamp, do not let band slip back through tool as this will decrease clamping force (refer to figure 17).

g. Back tool off just enough to permit tapping band with a hammer until it lies flat across top of retainer. Unwind the excess strap and cut it off close to retainer as shown in Figure 18. Tap the tabs down until they retain strap. Tap lightly as excessive force will damage seal (see figure 19).

## DISASSEMBLY (INNER C.V. JOINT)

1. With axle assembly on a bench, pry up staked areas on seal retainer and drive seal off housing with hammer and chisel. (Figure 21)

2. Grasp axle assembly with one hand and joint housing with the other and stand both vertically on the bench. Carefully withdraw axle from housing, being certain not to lose the balls and needles from the axle. (Figure 22)

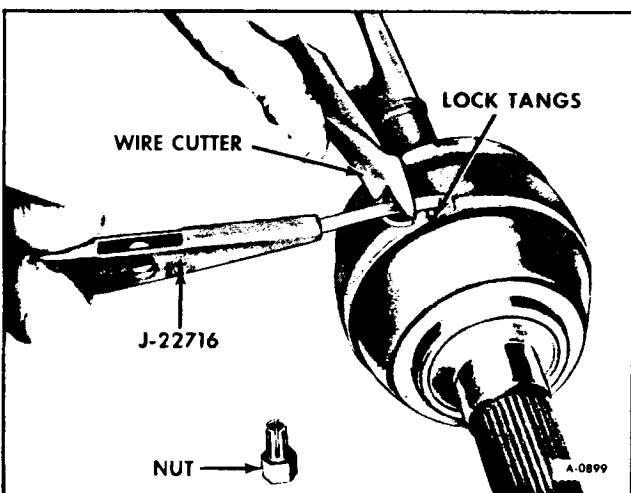

Figure 18—Cutting Off Band

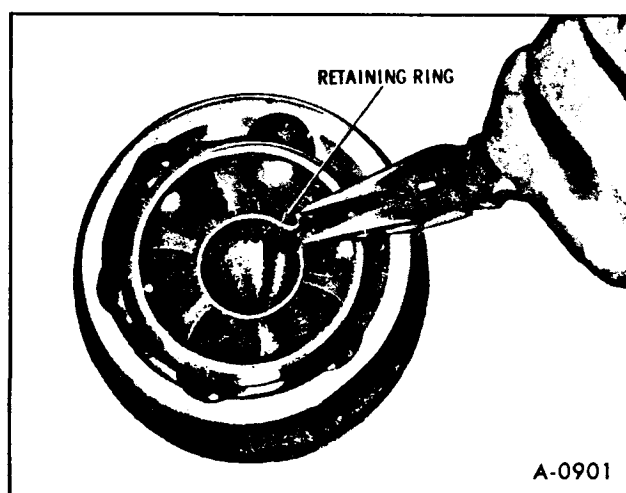

Figure 20—Removing Retaining Ring



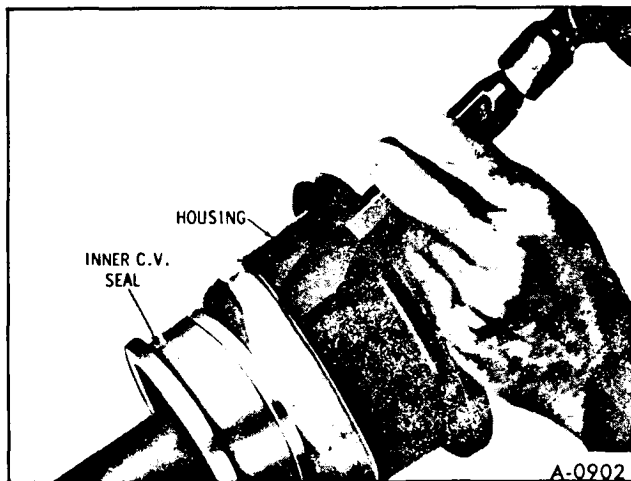

Figure 21—Removing Inner C.V. Joint Seal

**NOTE:** Place a rubber band over ends of spider to retain the three balls and needle bearings. Wipe all excess grease from C.V. parts joint. Remove housing “O” ring seal and discard. Set housing aside.

3. Insert axle assembly in vise. Clamp on mid-portion of axle shaft. Protect against jaw marks.

4. Using Tool J-5586, remove retaining ring from end of axle shaft.

5. Slide spider assembly from axle shaft. (figure 23)

6. Remove retaining ring (inner) from axle shaft using Tool J-5586. (figure 24)

7. Remove small seal clamp.

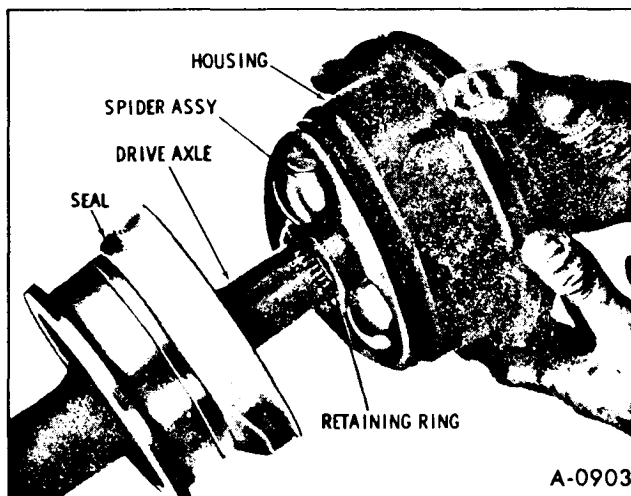

Figure 22—Removing Housing Assembly

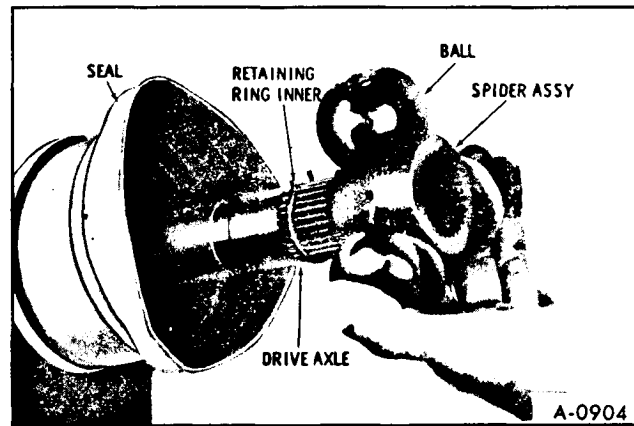

Figure 23—Removing Spider Assembly

8. Slide boot seal off axle shaft and discard seal.

**NOTE:** If there is no leakage or apparent damage to rear cup, it is not necessary to remove it from housing.

9. If necessary to remove cover, proceed as shown in Figure 25 and discard cover.

10. Remove “O” ring from housing and discard.

11. Remove balls (three) from spider, (figure 26) being careful not to lose any of the 53 needle bearings in each of the balls. (figure 27)

## CLEANING AND INSPECTION

Wash all metallic parts thoroughly in a cleaning solvent. Dry with compressed air.

Rubber boot seal, “O” rings and clamp should be

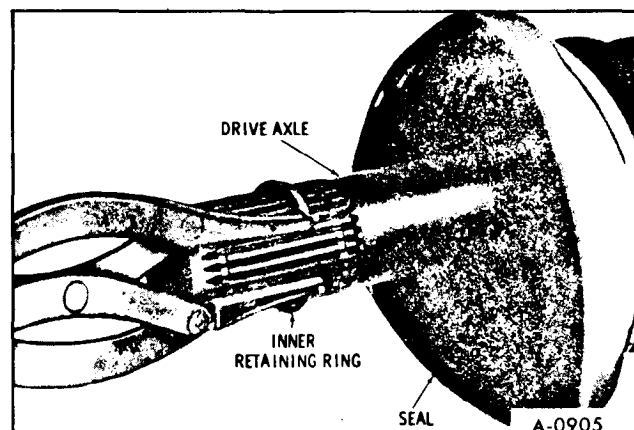

Figure 24—Removing Inner Retaining Ring

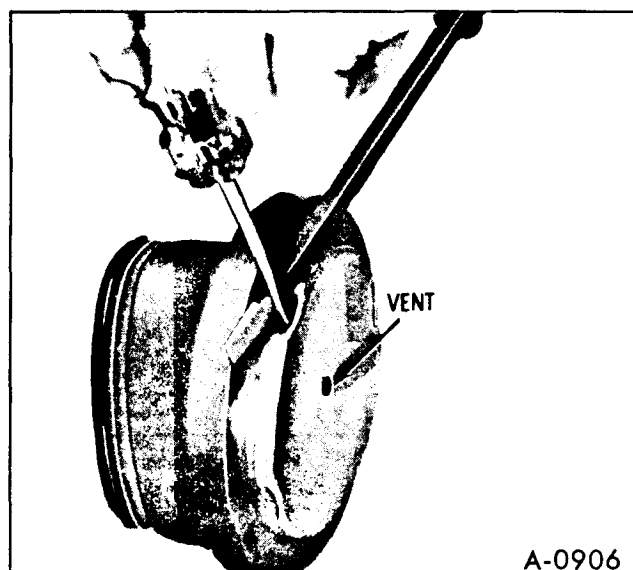

Figure 25—Removing Cover from Housing

replaced whenever C.V. joint is disassembled for service.

**NOTE:** Housing may show a definite polished area where the balls travel but C.V. joint need not be replaced. However, if this wear pattern is suspected to be the cause of a noisy or vibrating C.V. joint, then the housing should be replaced.

1. Inspect housing for excessive wear, brinelling, cracks or chips in housing bore.
2. Inspect retaining rings for cracks or bends.
3. Inspect balls (three) for excessive wear, cracks, nicks, scores or breaks.

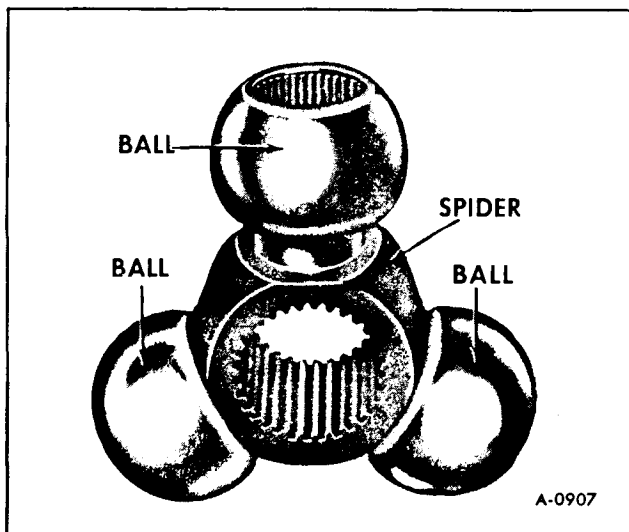

Figure 26—Spider Assembly

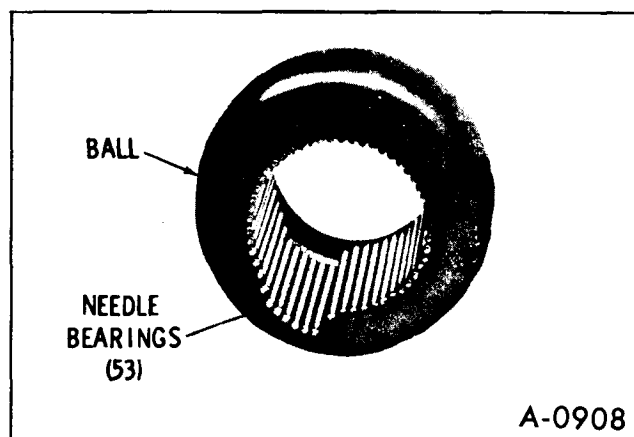

Figure 27—Spider Ball Needle Bearings

4. Inspect needle bearings for wear breaks or bends.
5. Inspect spider for excessive wear, chips or cracks.

## ASSEMBLY

1. Slide new clamp on axle shaft, to be used after seal positioning.
2. Slide seal onto axle shaft.
3. Position retaining ring on axle shaft in the inner groove. (figure 28)
4. Using Lubricant, No. 1050802, or equivalent load balls (three) with the needle bearings (53 to each ball). (figure 23)
5. Carefully install balls on each of the spider journals. (figure 26)

**NOTE:** A rubber band may be used to retain balls in position until spider assembly is installed in housing.

6. Position spider assembly on axle shaft and retain with retaining ring.

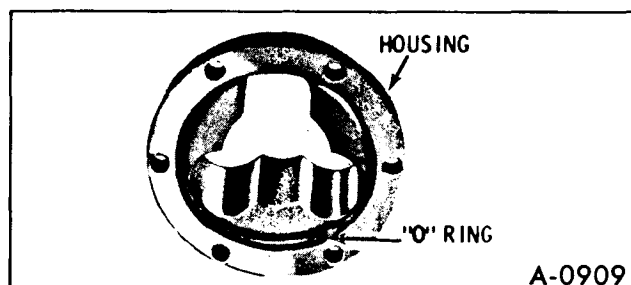

Figure 28—Installing "O" Ring in Housing

7. If rear cover was removed, install new "O" ring in housing and lubricate "O" ring with 1050802 lubricant or equivalent. (figure 28)

8. Install cover into housing using existing A/C Tool No. J-9397-2. Attach two machine bolts (1/4" x 2-1/4" Lg.) as shown in Figure 29 and tighten bolts alternately while tapping lightly with hammer until cover bottoms.

**NOTE:** Be careful that seal is positioned correctly so that "O" ring is not cut.

9. Install new "O" ring in outer groove in housing. (figure 30)

10. Pack housing approximately one-half full with lubricant 1050802 or equivalent.

11. Remove rubber band, if used, from spider assembly.

12. Position spider assembly in line with housing assembly and push into housing until bottomed. (figure 22)

13. Fill housing with lubricant 1050802 or equivalent.

14. Lubricate inside of boot seal retainer and housing outer groove "O" ring with 1050802 lubricant or equivalent.

**NOTE:** Be careful that seal retainer is positioned so that "O" ring is not cut.

15. With housing positioned as shown in Figure 31 tap seal retainer on three lobes alternately with plastic hammer as shown until firmly bottomed, then stake three places into staking groove.

16. Extend inboard joint to maximum length and

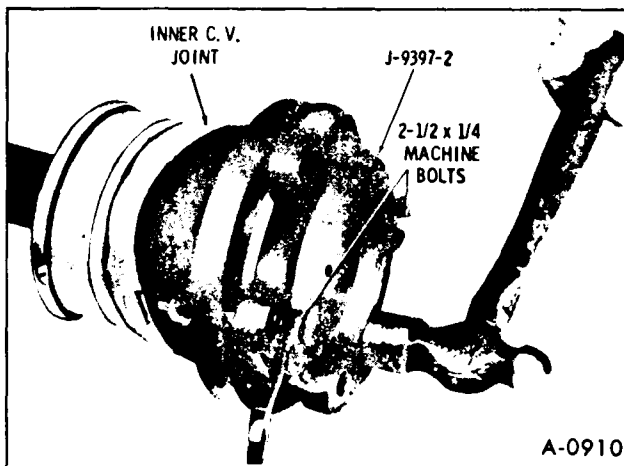

Figure 29—Installing Cover Into Housing

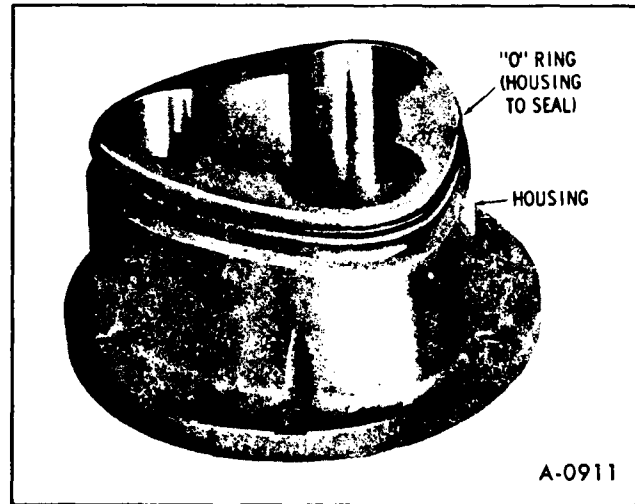

Figure 30—Installing "O" Ring on Housing  
position seal into furthest groove from joint in axle.

17. Install clamp following procedure outlined in Figures 15, 16, 17, 18, 19, and Outer C.V. Joint-Assembly-Step 13.

## DRIVE AXLE

### DISASSEMBLY

1. Remove drive axle assembly (Refer to DRIVE AXLE ASSEMBLY -R. or L. Removal).

2. Remove outer C.V. joint. Refer to Outer C.V. Joint-Disassembly.

3. Remove inner C.V. joint. Refer to Inner C.V. Joint-Disassembly.

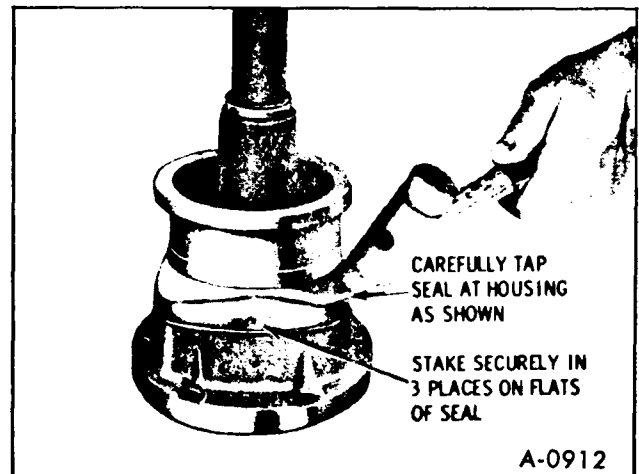

Figure 31—Installing Seal to Housing

**ASSEMBLY**

1. Assemble inner C.V. joint. Refer to Inner C.V. Joint Assembly.

2. Assemble outer C.V. joint. Refer to Outer C.V. Joint - Assembly.

3. Install drive assembly. (Refer to DRIVE AXLE ASSEMBLY - RIGHT OR LEFT INSTALLATION.)

**TORQUE SPECIFICATIONS**

Application	Ft. Lbs.
R.H. Output Shaft Support to Engine Bolts .....	55
Drive Axle to Output Shaft Bolts .....	65
Drive Axle Nut at Wheel Hub .....	110
Tie Rod End to Knuckle Nut .....	35
Ball Joint Stud Nuts .....	50

Nut must be tightened to insert cotter pin.

**SPECIAL TOOLS**

J-5586  
J-9397  
J-22716

Snap Ring Pliers  
C.V. Joint Cover Installer  
C.V. Joint Boot Clamp Tool

# SECTION 3C

## FINAL DRIVE

---

**CAUTION:** *Final drive axle fasteners are an important attaching part in that they could affect the performance of vital components and systems, and/or could result in major repair expense. They must be replaced with one of the same part number or with an equivalent part if replacement becomes necessary. Do not use a replacement part of lesser quality or substitute design. Torque values must be used as specified during reassembly to assure proper retention of this part.*

---

Contents of this section are listed below:

SUBJECT	PAGE NO.
Trouble Diagnosis .....	3C-1
General Description.....	3C-2
R.H. Output Shaft Bearing and Seal .....	3C-3
L.H. Output Shaft and Seal .....	3C-6
Transmission Filler Tube .....	3C-7
Final Drive.....	3C-7
Pinion Housing Seals.....	3C-9
Pinion Bearings .....	3C-12
Final Drive Case .....	3C-12
Final Drive Specifications .....	3C-21
Torque Specifications.....	3C-21
Special Tools .....	3C-21

### TROUBLE DIAGNOSIS

Many noises reported as coming from the final drive actually originate from other sources such as tires, road surfaces, engine, transmission, muffler or body drumming. A thorough and careful check should be made to determine the source of the noise before disassembling the final drive. Noise which originates in other places cannot be corrected by adjustment or replacement of parts in the final drive. It should also be remembered that final drive gears, like any other mechanical device, are not absolutely quiet and should be accepted as being commercially quiet unless some abnormal noise is present.

To make a systematic check for final drive noise under standard conditions, observe the following:

1. Select a level tarvia or asphalt road to reduce tire noise and body drumming.
2. Check final drive lubricant to assure correct level, then drive vehicle far enough to thoroughly warm up the lubricant.
3. Note speed at which noise occurs. Then stop Motor Home and with automatic transmission in neutral, run engine slowly up and down through engine speeds, corresponding to vehicle speed at

which noise was most pronounced, to determine if it is caused by exhaust muffler roar or other engine conditions.

## AXLE NOISES

### Gear Noise

After the noise has been determined as being in the final drive by following the above appraisal procedure, the type of final drive noise should be determined to aid in making repairs if necessary.

Gear noise (whine) is audible from 20 to 65 mph under four driving conditions.

1. Drive - Acceleration or heavy pull.
2. Road Load - Motor Home driving load or constant speed.
3. Float - Using enough throttle to keep the Motor Home from driving the engine - Motor Home slows down gradually but engine still pulls slightly.

4. Coast - Throttle closed and Motor Home in gear. Gear noise most frequently has periods where noise is more prominent, usually 30 to 40 mph and 50 to 60 mph.

### Bearing Noise

Bad bearings generally produce more of a rough growl or grating sound, rather than the whine typical of gear noise. Bearing noise frequently "WOW-WOWS" at bearing rpm, indicating a defective pinion or differential side bearing.

## GENERAL DESCRIPTION (Figures 1, 2 and 3)

The final drive assembly, mounted and splined directly to the automatic transmission, consists of a pinion drive and ring gear set (with a ratio of 3.07:1), case assembly with two side gears and two pinion gears which are retained to the case with a pinion shaft. A lock pin is used instead of a bolt to lock the

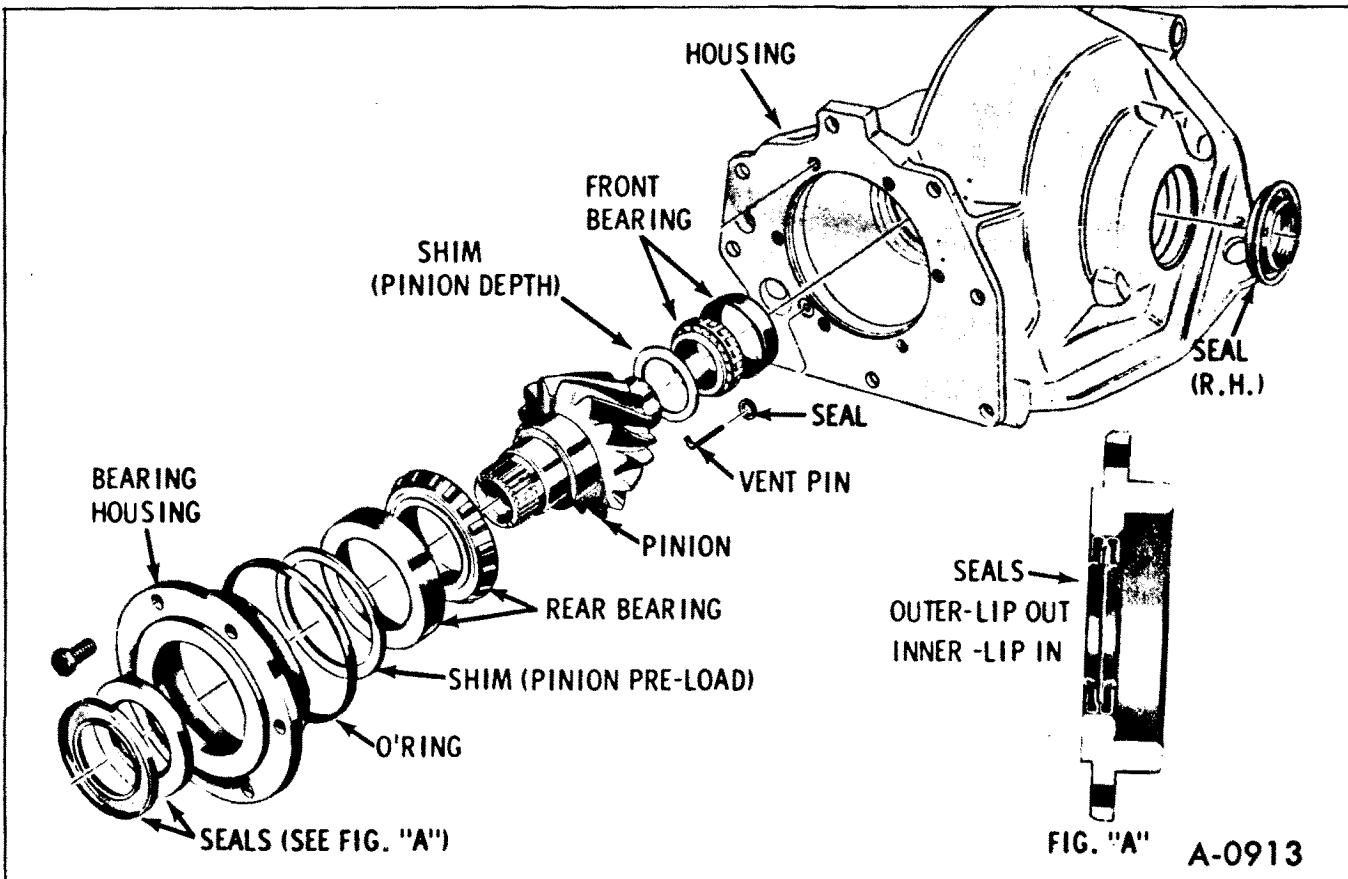

Figure 1-Final Drive Pinion Assembly

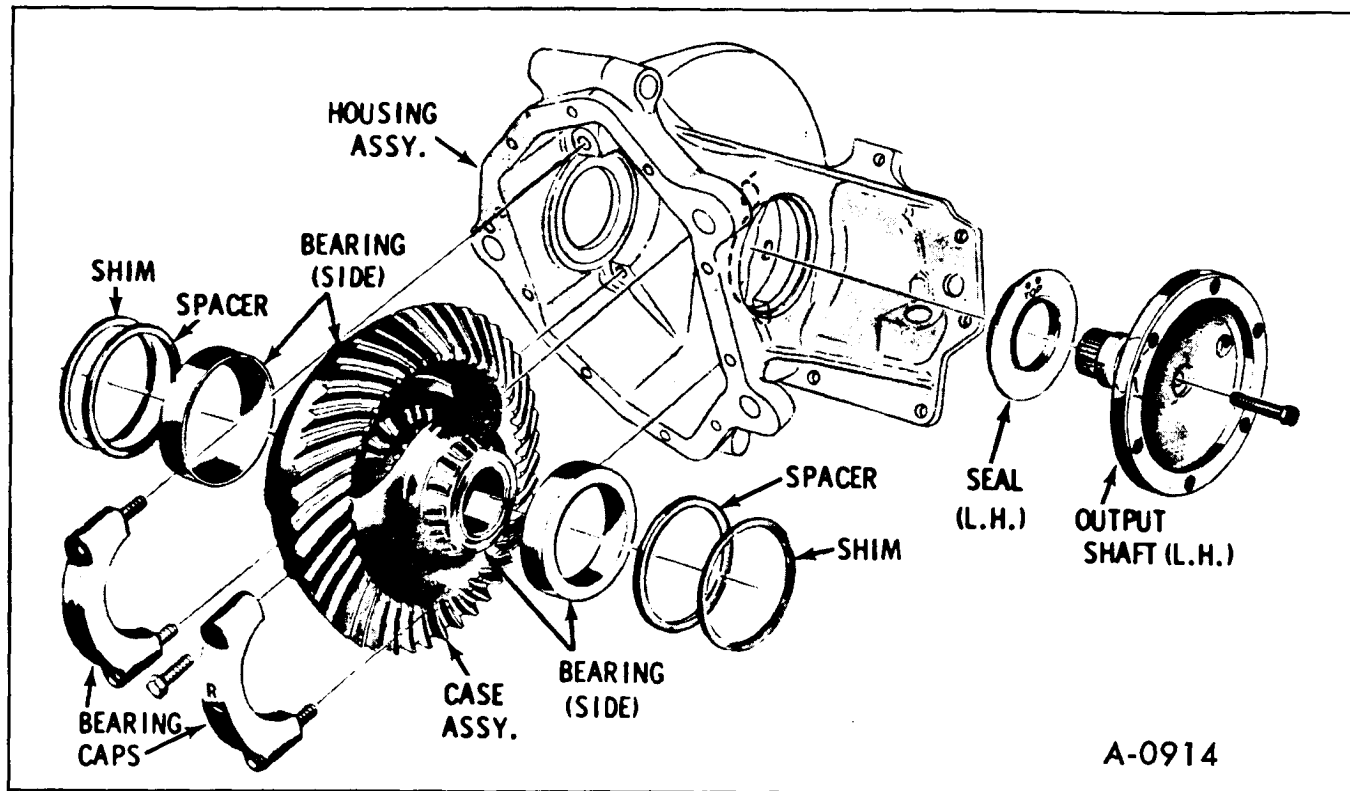

Figure 2-Final Drive Case Assembly

pinion shaft to the case. There are thrust washers used behind the side gears and shims behind the pinion gears the same as the conventional differential. The left side gear is different than the right side in the respect that it has a threaded retainer plate that the left output shaft bolts to. The two side bearings are the same and the pre-load shims are identical for the right and left side.

The left output shaft has the retainer bolt going through the shaft to the side gear. The right output shaft has a vent hole in the flange.

**CAUTION:** When removing or installing the right drive axle, be sure to disconnect the negative battery cables. It is possible to short out the starter motor by making contact between the wrench and the starter motor terminals.

## RH OUTPUT SHAFT, BEARING AND SEAL

### REMOVAL

1. Disconnect battery cables.

2. Hoist Motor Home.

3. Remove attaching bolts, R.H. Drive axle to R.H. output shaft. Then move drive axle rearward until free from output shaft.

4. Disconnect support from engine. (figure 4)

5. Remove output shaft assembly.

6. If output shaft seal is to be replaced, install Seal Remover J-23129 into seal and drive seal out with a hammer. (figure 5)

7. If output shaft bearing is to be replaced, it can be removed with a press as shown in Figure 6.

### INSTALLATION

See CAUTION on Page 3C-1 of this section.

1. If output shaft bearing was removed, assemble parts as shown in Figure 7.

2. Position assembly in a press and install bearing until seated as shown in Figure 8.

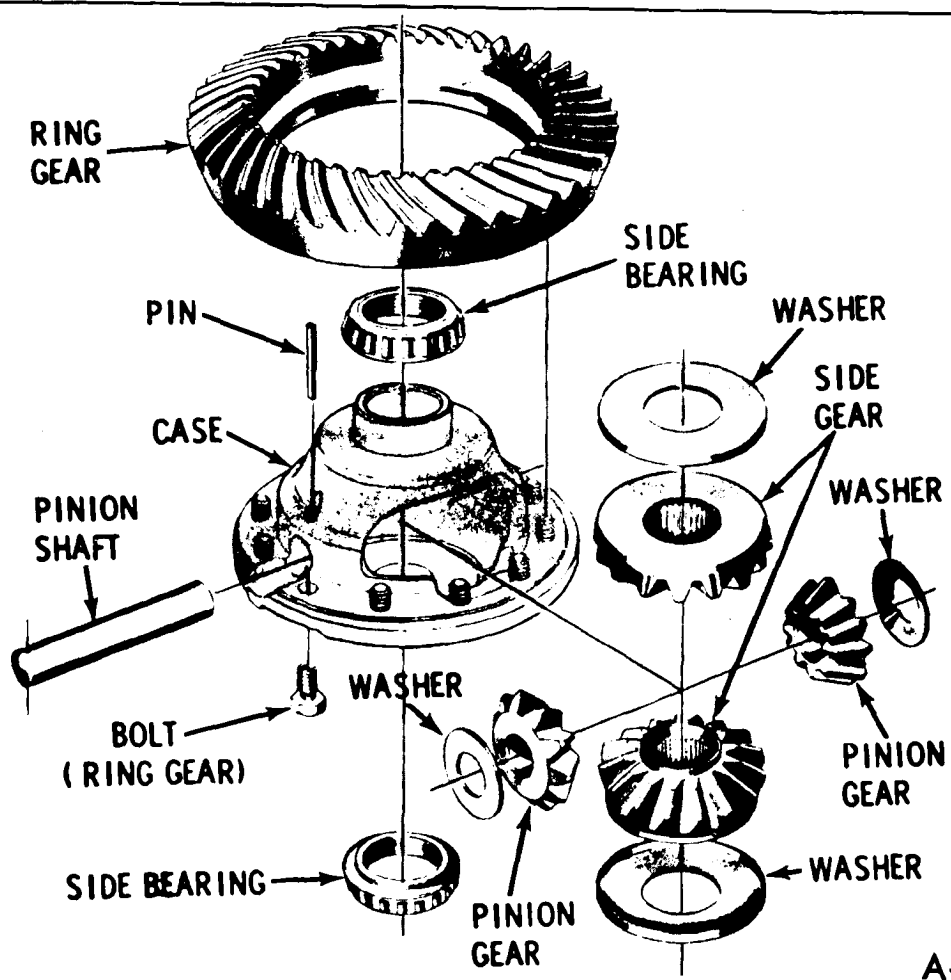

A-0915

Figure 3-Final Drive Case Assembly (Exploded View)

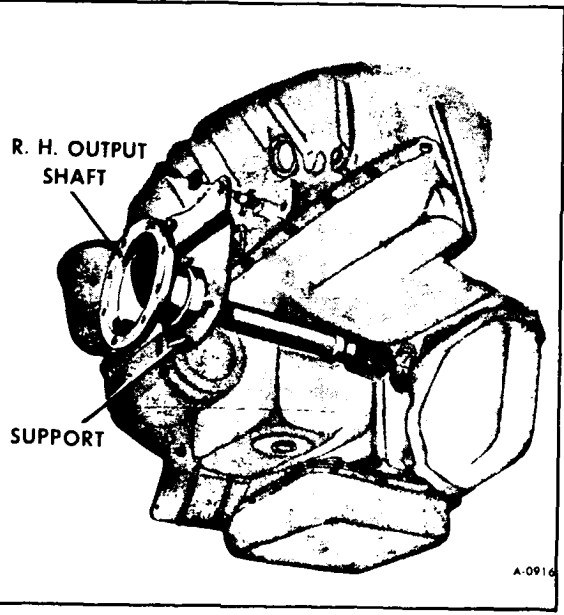

A-0916

Figure 4-R.H. Output Shaft Attachment

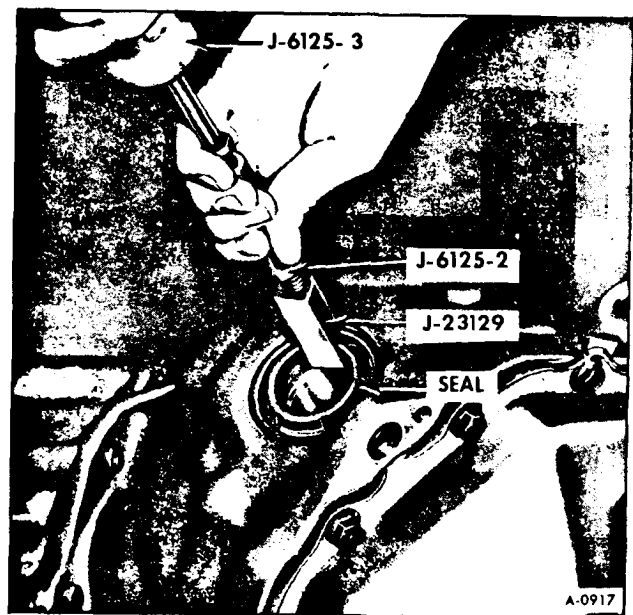

A-0917

Figure 5-Removing R.H. Output Shaft Seal



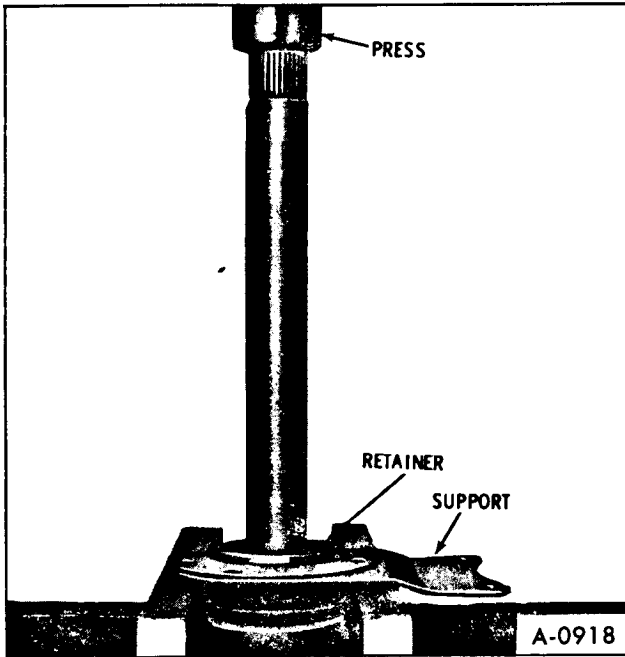

Figure 6—Removing R.H. Output Shaft Bearing

3. Pack area between bearing and retainer with wheel bearing grease, then install slinger as shown in Figure 9.

4. If output shaft seal was removed, new seal can be installed as shown in Figure 10.

5. Apply Special Seal Lubricant No. 1050169 or equivalent to output shaft seal, then install output shaft into final drive indexing splines of output shaft with splines in side gear.

6. Install support to engine and brace. (figure 4)

**NOTE:** When attaching the right hand output

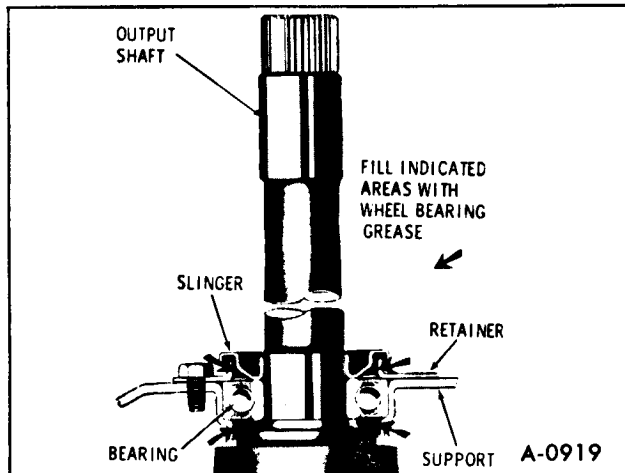

Figure 7—R.H. Output Shaft Assembly

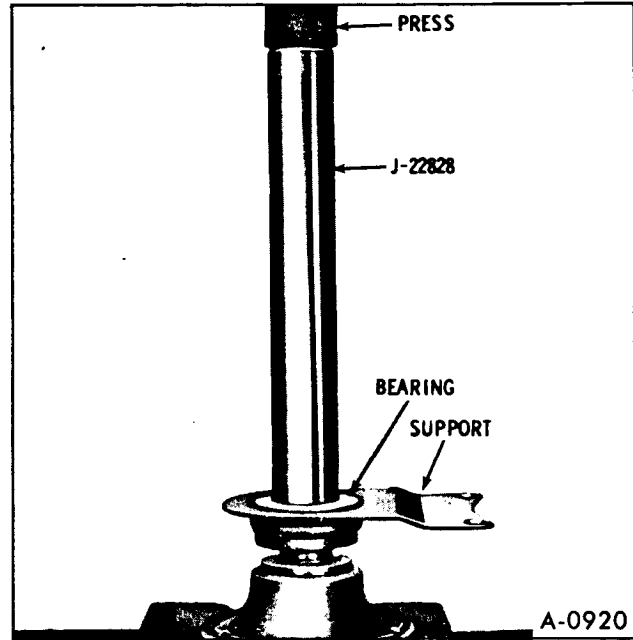

Figure 8—Installing R.H. Output Shaft Bearing

shaft to the engine, do not let the shaft hang. Assemble support bolts loosely, and by moving the flange end of the shaft up and down, and back and forth, find the center location. Hold the shaft in this position and then torque the bolts to 55 ft. lbs. on support. Figure 11.

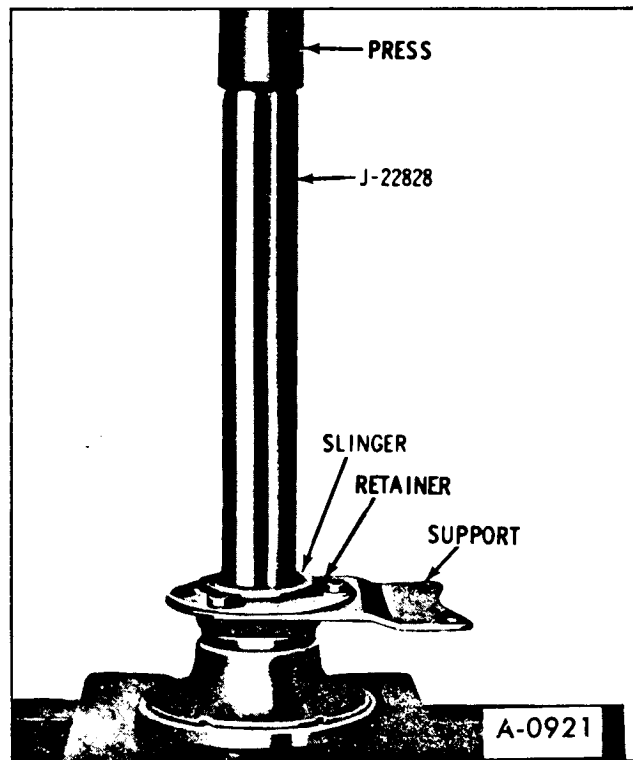

Figure 9—Installing Slinger

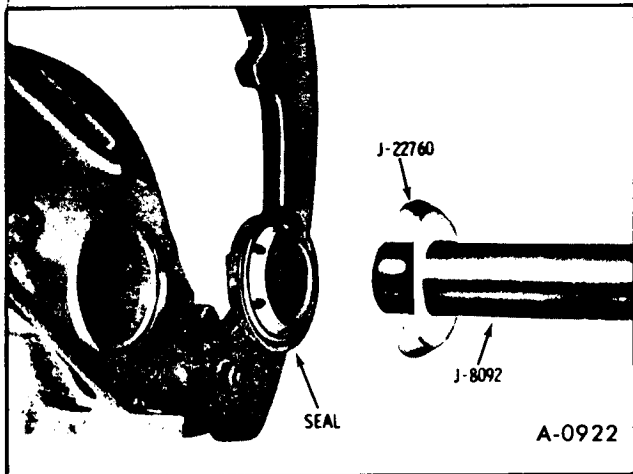

Figure 10—Installing R.H. Output Shaft Seal

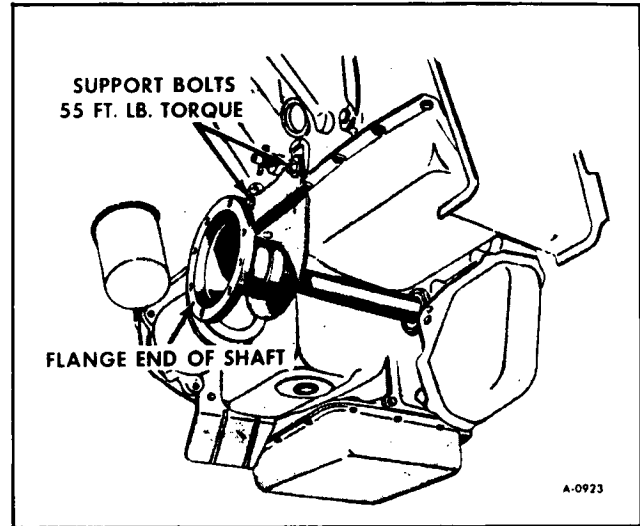

Figure 11—Aligning R.H. Output Shaft

7. Move drive axle forward until alignment with output shaft is obtained. Install NEW attaching bolts. Torque to 65 ft. lbs.

8. Connect battery cables.

9. Check final drive oil level and check for oil leaks.

## LH OUTPUT SHAFT AND SEAL

### REMOVAL

1. Remove L.H. Drive axle. Refer to Section 3B "DRIVE AXLE ASSEMBLY (LEFT HAND)", Steps 1 through 12 under "REMOVAL."

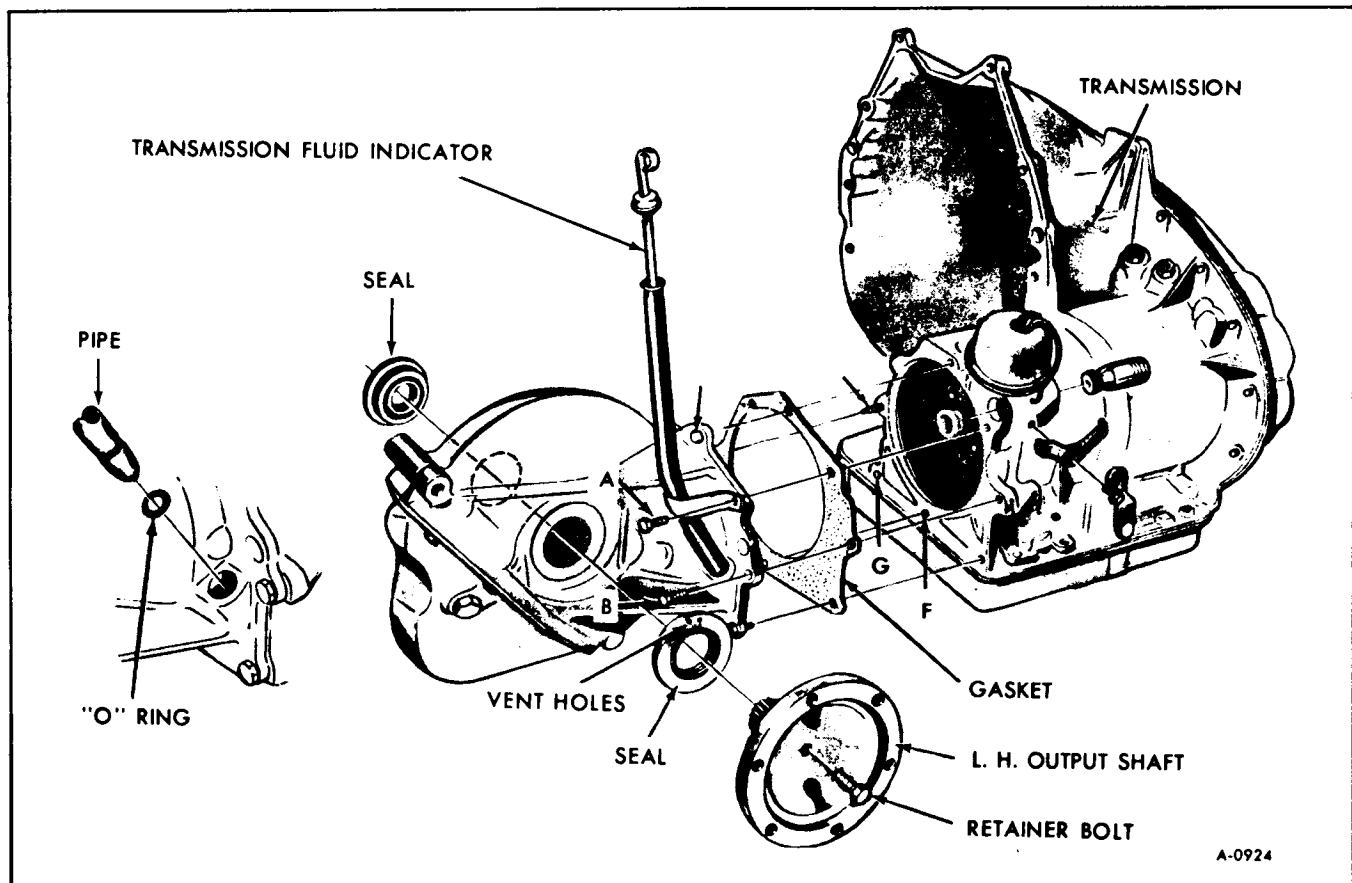

Figure 12—Final Drive Attachment

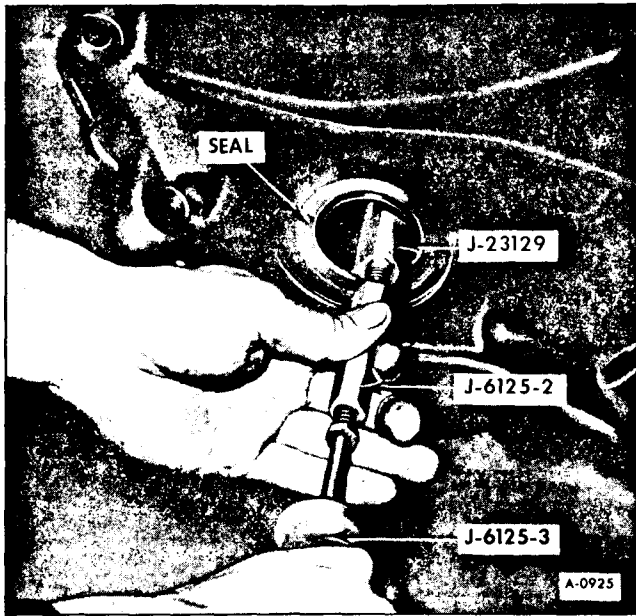

Figure 13—Removing L.H. Output Shaft Seal

2. Using a 9/16" socket remove L.H. output shaft retaining bolt and remove L.H. output shaft. (figure 12)

If output shaft seal is to be replaced, insert Tool J-23129 into seal and drive out with a hammer. (figure 13)

## INSTALLATION

See CAUTION on Page 3C-1 of this section.

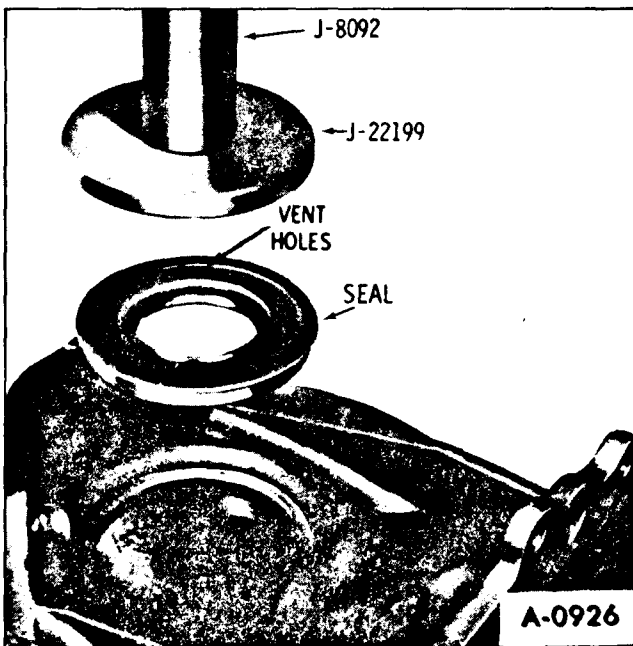

Figure 14—Installing L.H. Output Shaft Seal

1. If output shaft seal was removed, install new seal as shown in Figure 14.

**NOTE:** Left output shaft seal is installed with vent hole toward top of final drive housing in the in-vehicle position.

2. Apply Special Seal Lubricant No. 1050169 or equivalent to the seal; then, insert output shaft into final drive assembly, indexing splines of output shaft with splines in side gear.

3. Install L.H. output shaft retaining bolt and torque to 40 ft. lbs. (figure 12)

4. Install L.H. drive axle. Refer to Section 3B, DRIVE AXLE ASSEMBLY (LEFT HAND), Steps 1 through 10 under INSTALLATION.

## TRANSMISSION FILLER TUBE REMOVAL AND INSTALLATION

The automatic transmission filler tube is located on the final drive. The filler tube can be removed by removing bolt "A", Figure 12 and then pulling the filler tube out of the housing. To install, position a new "O" ring seal on the filler tube. Coat seal with Special Seal Lubricant No. 1050169 or equivalent and install filler tube into housing. Install bolt "A" and torque to 25 ft. lbs.

## FINAL DRIVE

### REMOVAL

1. Disconnect battery cables.
2. Hoist Motor Home.
3. Remove bolts "A", "B", and "C". (Figure 12)
4. Disconnect right and left drive axles from the output shafts.
5. Move R.H. Drive axle rearward until R.H. output shaft is clear to be removed from final drive.
6. Disconnect R.H. output shaft support from engine (figure 4) and remove from final drive.
7. Remove bolt "X" and "Y" and loosen "Z". (figure 15)
8. Remove final drive cover and allow lubricant to drain.



Figure 15—Disconnecting Final Drive From Engine

9. Position transmission jack with adapter for final drive as shown in Figure 16. Install an anchor bolt through final drive housing and lift pad.

**NOTE:** Adapters for removing final drive assemblies are available from most transmission jack manufacturers.

10. Remove bolts "E", "F" and "G" and nut "H" (figure 12).

11. Move transmission lift toward front of Motor Home to disengage final drive splines from transmission.

**NOTE:** As the final drive is disengaged from

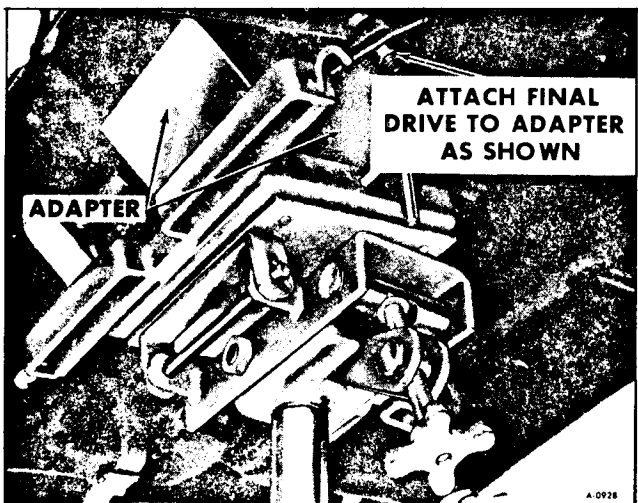

Figure 16—Connecting Lift to Final Drive

transmission, some transmission fluid will be lost. Provide a container to prevent oil from running on floor.

12. Pivot final drive support bracket upward for clearance.

13. Lower transmission lift and remove final drive from lift.

14. Using a 9/16" socket remove the left output shaft retainer bolt, then pull output shaft from final drive. (figure 12)

15. Remove transmission to final drive gasket.

## INSTALLATION

See CAUTION on Page 3C-1 of this section.

1. Apply Special Seal Lubricant No. 1050169 or equivalent to both output shaft seals.

2. Install the left output shaft into the final drive. Retain with bolt. Torque bolt to 40 ft. lbs. (figure 12)

3. Position final drive on transmission lift and install an anchor bolt through housing and lift pad. (figure 16)

4. Apply a thin film of Special Seal Lubricant No. 1050169 or equivalent on the transmission side of a new final drive to transmission gasket, then position gasket on transmission.

5. Raise transmission lift. Align the bolt stud "H" on the transmission with the mating hole in the final drive. Move final drive until it mates with the transmission. (Figure 12)

**NOTE:** It may be necessary to rotate the left output shaft so that the splines of the final drive pinion engage the splines of the transmission output shaft. Do not allow gasket to become mispositioned while engaging splines.

6. Install bolts "E", "F" and "G" and nut "H" (figure 12). Install bolts "A", "B" and "C". (figure 12) Torque all final drive to transmission bolts to 25 ft. lbs. Torque nut to an approximate 25 ft. lbs.

7. Install bolt "X" and torque to 105 ft. lbs. Tighten and torque bolts "Y" and "Z" to 50 ft. lbs. (figure 15)

8. Loosen and remove lift from final drive.

9. Position a new cover gasket on the final drive, then install cover. Torque cover bolts to 25 ft. lbs.

10. Install right output shaft into final drive indexing splines of output shaft with splines of side gear. Install support bolts.

**NOTE:** When attaching the right hand output shaft to the engine, do not let the shaft hang. Assemble support bolts loosely, and by moving the flange end of the shaft up and down, and back and forth, find the center location. Hold the shaft in this position and then torque the bolts to 55 ft. lbs. on support. (Figure 11).

11. Connect drive axles to output shafts using NEW bolts. Torque bolts to 65 ft. lbs.

12. Raise hoist, remove floor stands and lower Motor Home.

13. Install a new "O" ring and install filler tube.

14. Connect battery cables.

15. Fill final drive with 4 pints of Lubricant No. 1051022 or equivalent. Fluid level should be maintained at "Fill Level" stamped on final drive cover.

16. Start engine and check transmission fluid level. Add fluid as necessary.

17. Check for any oil leaks.

## PINION HOUSING SEALS

### REMOVAL

1. Remove final drive. Refer to final drive removal steps 1-13.

2. Remove the bearing housing bolts. Remove the drive pinion and housing as shown in Figure 24. Remove housing from drive pinion. Remove "O" ring seal from O.D. of bearing housing.

3. Using a punch, drive seals out of housing on the opposite side of the rear pinion bearing outer race.

### INSTALLATION

See CAUTION on Page 3C-1 of this section.

1. Position seals as shown in Figure 45 and using Tool J-22212, drive seals into housing until tool bottoms.

2. Position drive pinion into final drive and install Seal Protector J-22236 over end of pinion.

**CAUTION:** Seal protector must be used or inner seal lip will fold between seal case and pinion shaft resulting in a leak.

3. Install new "O" ring over O.D. of bearing housing and install bearing housing over seal protector into position on the housing. Torque bearing housing attaching bolts alternately to 35 ft. lbs. Remove seal protector.

4. Apply Special Seal Lubricant No. 1050169 or equivalent to right output shaft seal.

5. Install final drive. Refer to FINAL DRIVE-INSTALLATION steps 3-17.

## FINAL DRIVE (REMOVED FROM VEHICLE)

### DISASSEMBLY

1. Install adapter J-22296-1 on Differential Holding Fixture J-3289. Mount final drive in holding fixture as shown in Figure 17.

2. Rotate housing so that pinion is up. Install tools as shown in Figure 18, and turn torque wrench several turns and record torque reading. This combined pinion and side bearing pre-load reading will be helpful in determining cause of final drive failure. Remove tools and rotate carrier so that pinion is down.

3. Rotate differential case several times to seat

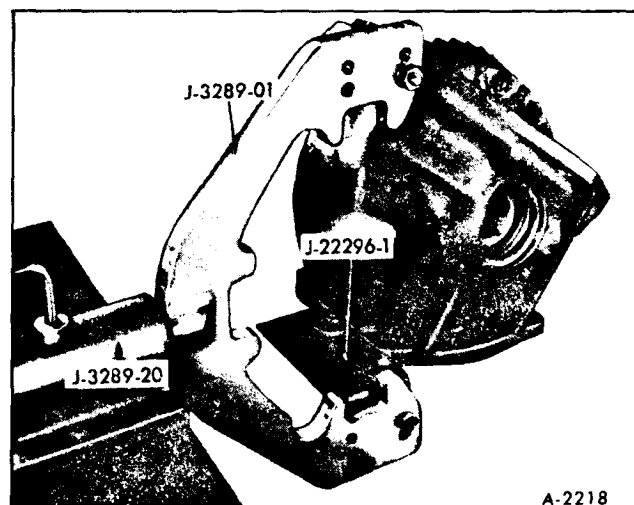

Figure 17—Final Drive Holding Fixture

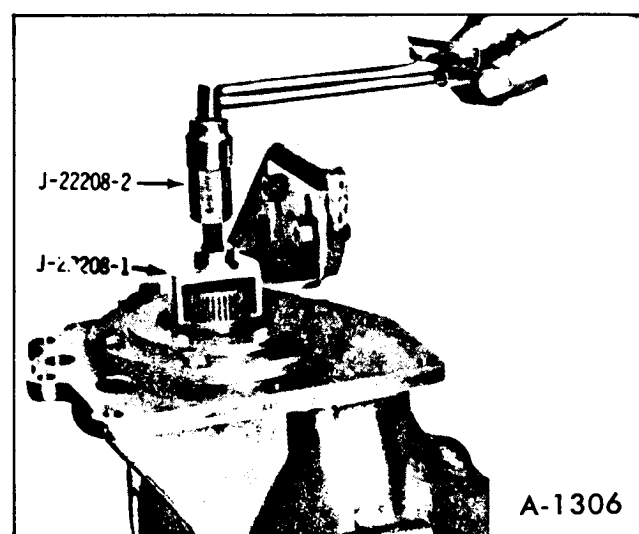

Figure 18—Checking Pinion and Side Bearing Pre-Load

bearings, then mount dial indicator as shown in Figure 19. Use a small button on the indicator stem so that contact can be made near heel end of tooth. Set dial indicator so that stem is in line as nearly as possible with gear rotation and perpendicular to tooth angle for accurate backlash reading.

4. Check backlash at three of four points around ring gear. Lash must not vary over .002" around ring gear.

**NOTE:** Pinion must be held stationary when checking backlash. If variation is over .002" check for burrs, uneven bolting conditions or distorted case and make corrections as necessary.

5. Remove side bearing cap bolts.

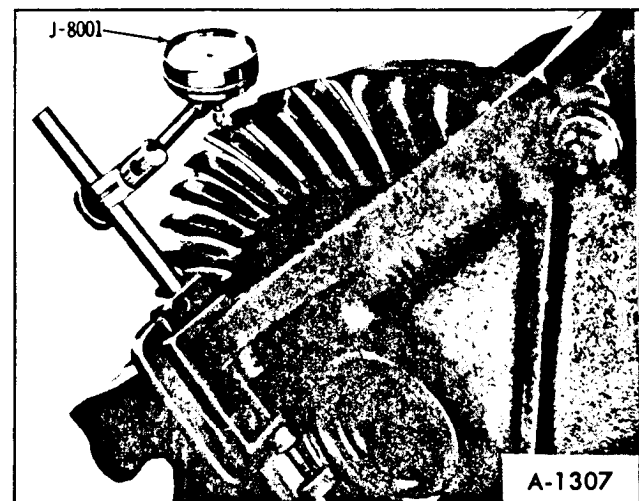

Figure 19—Checking Ring Gear to Pinion Gear Backlash

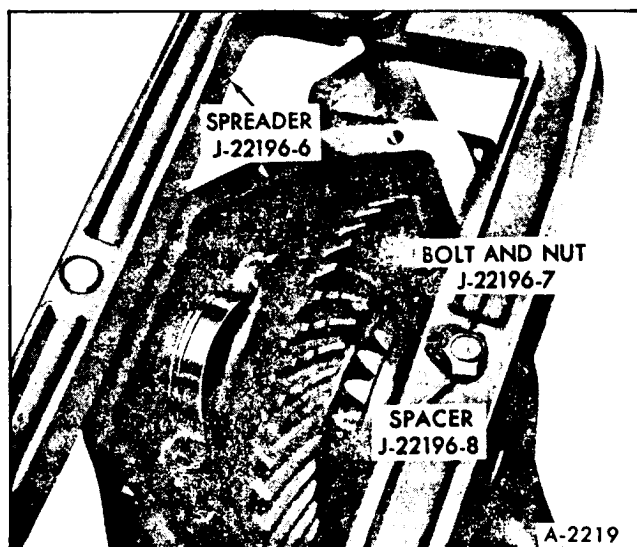

Figure 20—Spreader Installation

**NOTE:** Bearing caps are of same size and must be installed in their original position. Mark right and left bearing caps to identify for reassembling. Keep the original bearing outer races with their corresponding caps.

6. Install spreader on housing as shown in Figure 20.

**NOTE:** Spreader must be modified with Tools J-22196-7-8.

7. Turn the spreader screw to expand spreader until the spacer and shim(s) can be removed from between the right side bearing and the housing. Retain spacers and shims for reassembly.

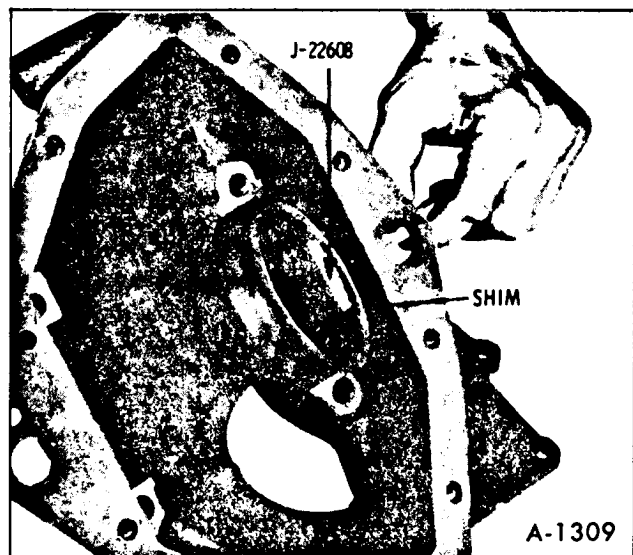

Figure 21—Removing Shims

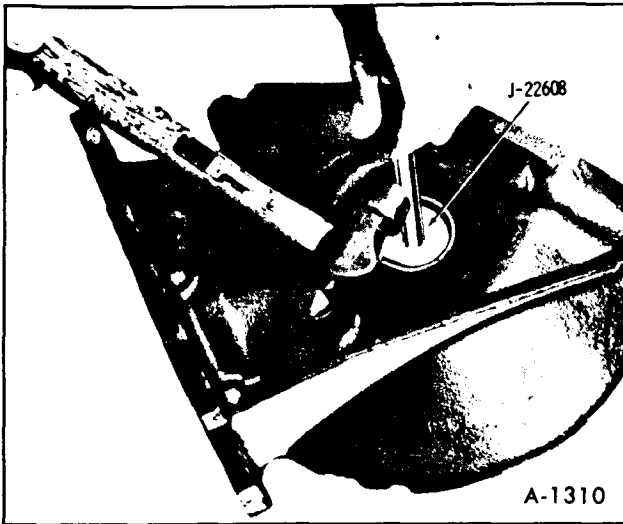

Figure 22—Positioning Tool J-22608

**NOTE:** Spread housing only enough to relieve tension on the spacer and shims. The shims may be removed with Tool J-22608 as shown in Figures 21 and 22.

8. Remove spreader from housing.

9. Remove the spacer and shims, then slide the case assembly to the left, away from the pinion gear. Remove case assembly from housing.

10. Rotate housing so that the pinion is up. Check pinion bearing pre-load as shown in Figure 23. Record the pinion bearing pre-load.

11. Remove the bearing housing bolts. Remove the drive pinion and housing as shown in Figure 24. Remove housing from drive pinion. Remove "O" ring seal from bearing housing.

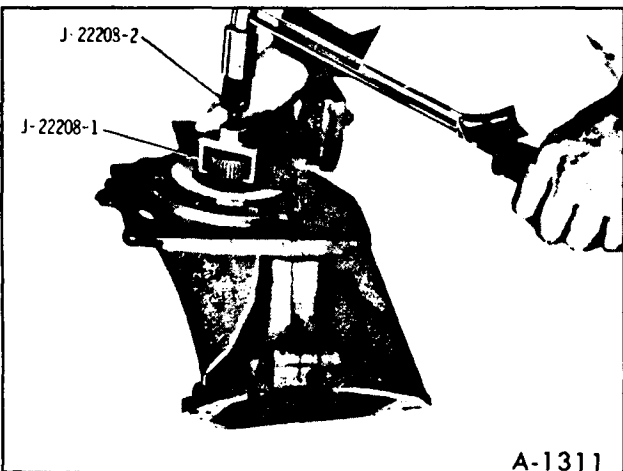

Figure 23—Checking Pinion Pre-Load

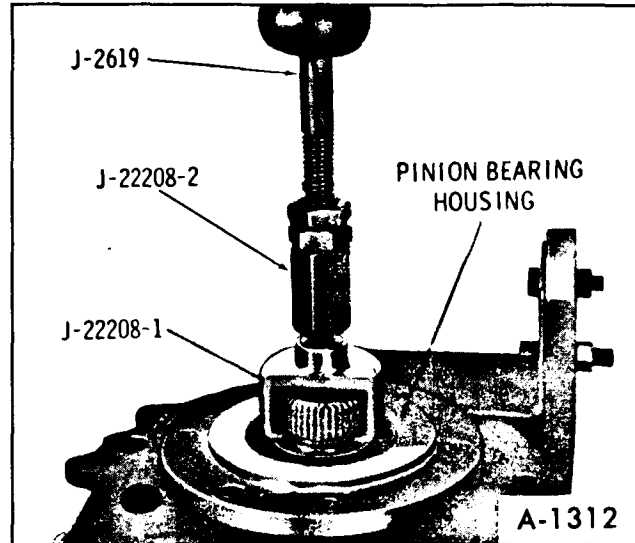

Figure 24—Removing Pinion And Bearing Housing

12. Remove seal and vent pin from housing. (figure 25)

13. Install Tool J-22201 on Slide Hammer J-2619. Position Tool J-22201 as shown in Figure 26, and tighten screw. Remove pinion front bearing outer race.

14. Remove the output shaft oil seals as shown in Figures 5 and 13.

15. Remove the two oil seals from the pinion bearing housing as shown in Figure 27.

16. If necessary to remove the pinion rear outer race, it can be removed as shown in Figure 28.

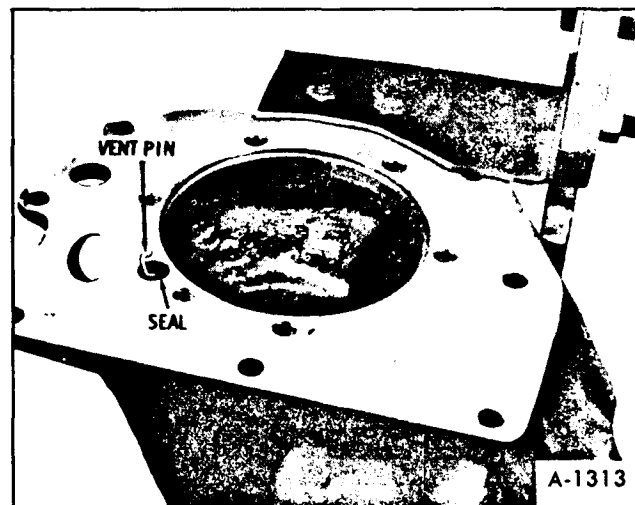

Figure 25—Removing Vent Pin And Seal

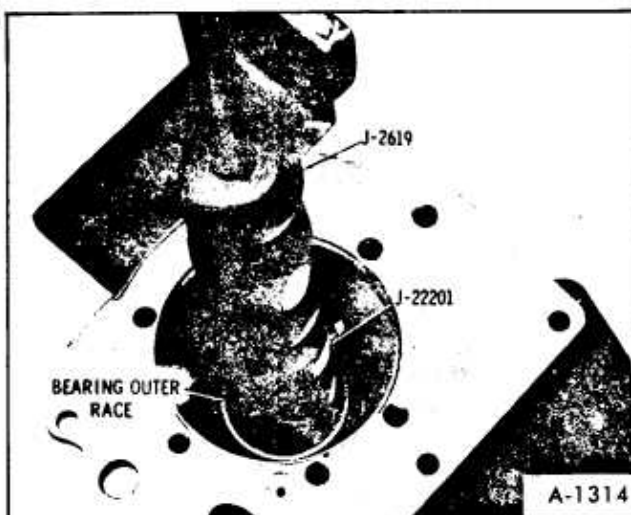

Figure 26—Removing Pinion Front Bearing Outer Race

## PINION BEARINGS

### REMOVAL

1. Remove the pinion front bearing and selective shim as shown in Figure 29. Bearing can be removed without Tool J-8433-1 if a press is available.

2. Remove the pinion rear bearing as shown in Figure 30.

## FINAL DRIVE CASE

### DISASSEMBLY

1. If the side bearings are to be removed, they can be removed as shown in Figures 31 and 32.

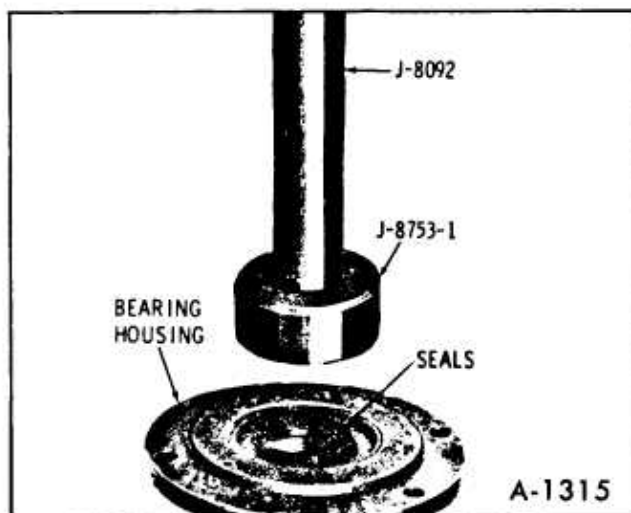

Figure 27—Removing Oil Seals From Pinion Bearing Housing

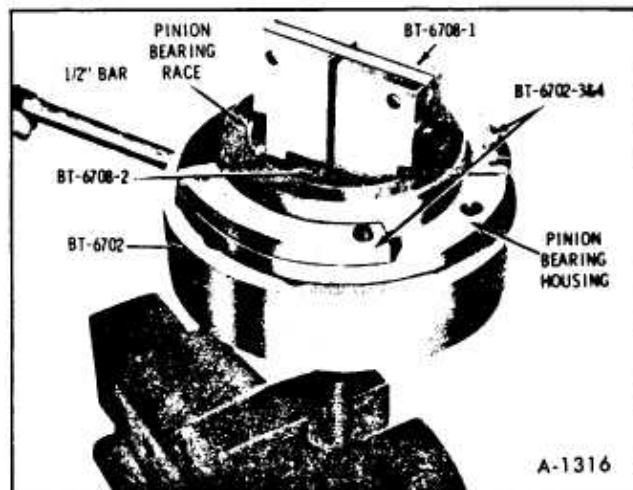

Figure 28—Removing Pinion Rear Bearing Outer Race

2. Mark ring gear and case, then remove all but two of the case to ring gear bolts. Leave two of the bolts, 180° apart, loose.

**NOTE:** Ring gear must be removed to remove pinion and side gears.

3. Position case as shown in Figure 33 and tap lightly on a bench to separate the case from ring gear.

4. Remove the two remaining ring gear bolts and separate ring gear from case.

5. Drive lock pin from pinion shaft with a 3/16" punch (figure 34).

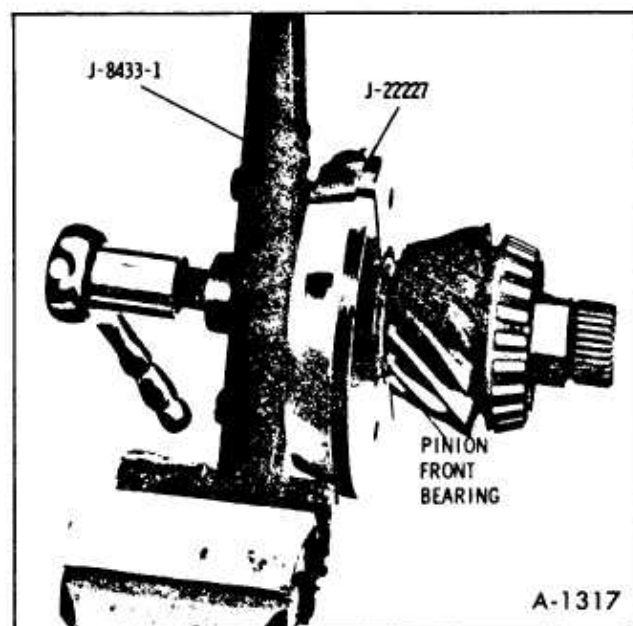

Figure 29—Removing Pinion Front Bearing



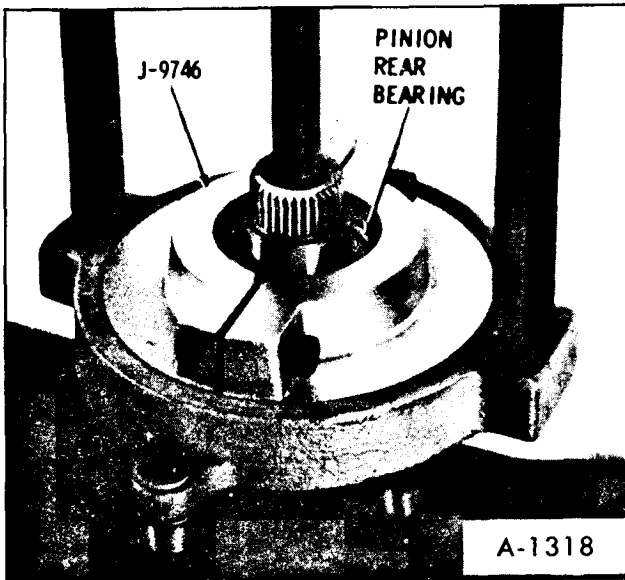

Figure 30—Removing Pinion Rear Bearing

6. Push pinion shaft out of case.

7. Rotate one pinion gear and shim towards access hole in case and remove.

**NOTE:** Keep the corresponding shims and pinion gear together for correct assembly.

8. Remove the other pinion gear and shim.

9. Remove side gears keeping the same thrust washer with the side gear it is mated with. Inspect thrust washers and shims for wear and replace as necessary.

**NOTE:** The left side gear has the threaded retainer that retains the (short) left output shaft.

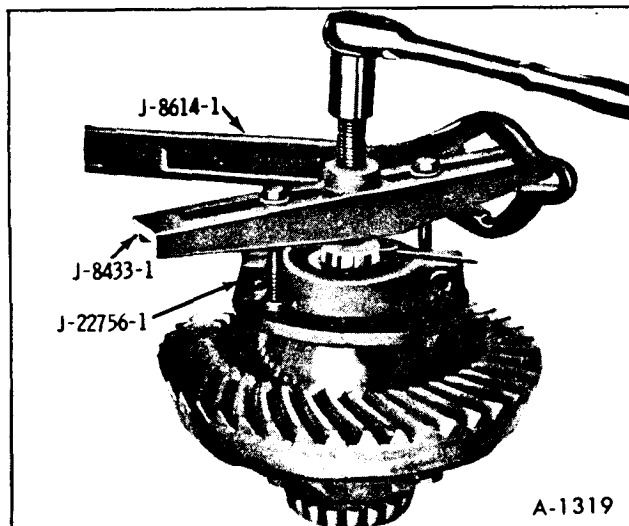

Figure 31—Removing Left Side Bearing

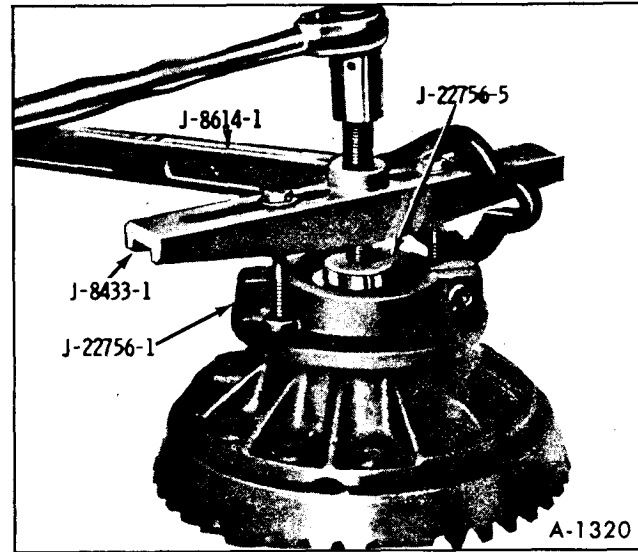

Figure 32—Removing Right Side Bearing

If threaded retainer is to be removed, use a brass drift and hammer to remove from left side gear.

## CLEANING AND INSPECTION

1. Clean all bearings thoroughly in clean solvent. (Do not use a brush). Examine bearings visually and by feel. All bearings should feel smooth when oiled and rotated while applying as much hand pressure as possible.

**NOTE:** Minute scratches and pits that appear on rollers and races at low mileage are due to the initial pre-load and bearings having these marks should not be rejected.

2. Examine the ring gear and drive pinion teeth for excessive wear and scoring. Any of these conditions will require replacement of the gear set.

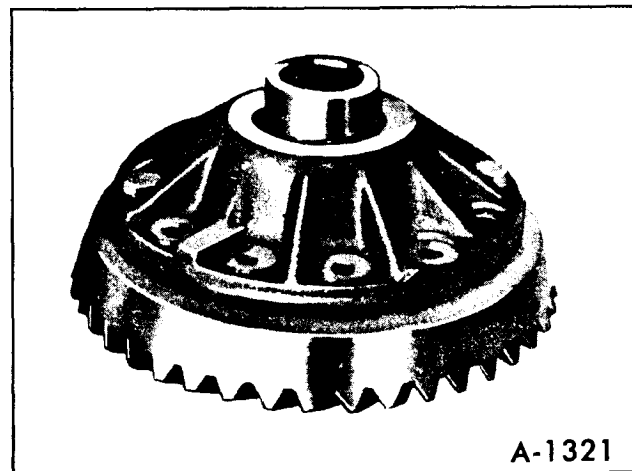

Figure 33—Separating Ring Gear From Case

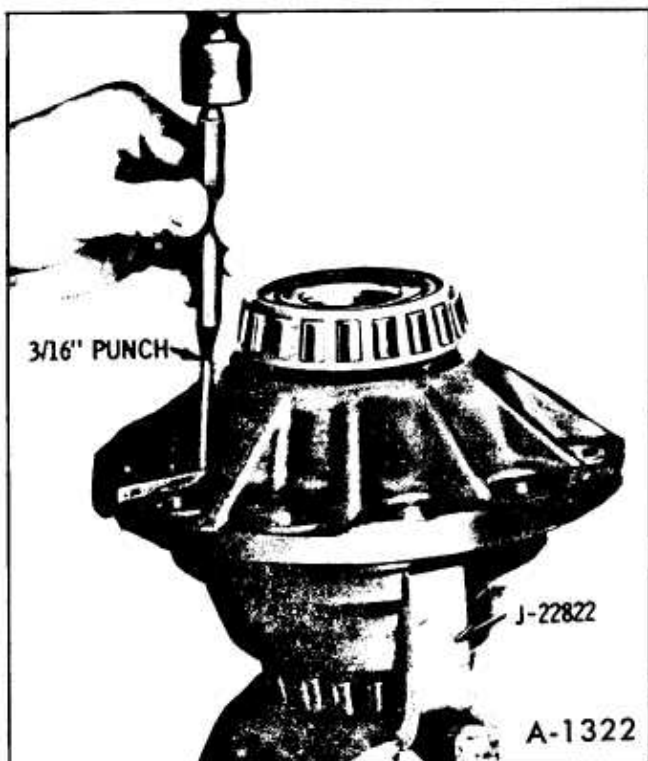

Figure 34—Removing Lock Pin From Pinion Shaft

3. Examine housing bores and remove any burrs that might cause leaks around the OD of the seal.

4. Inspect the differential pinion shaft for unusual wear; also check the pinion and side gears and thrust washers.

5. Side beatings must be a tight press fit on the hub.

6. Diagnosis of a differential failure such as chipped bearings, loose (lapped-in) bearings, chipped gears etc. is a warning that some foreign material is present; therefore, the housing must be thoroughly cleaned and inspected.

## CHECKING PINION DEPTH

1. Install pinion front outer race as shown in Figure 35. Drive race until it bottoms.

2. Lubricate front bearing with final drive lubricant and install into front outer race.

3. Position Tool J-21777-10 on front bearing. Install Tool J-21579 on final drive housing and retain with two bolts. Thread screw J-21777-13 into J-21579 until tip of screw engages Tool J-21777-10. Torque screw J-21777-13 to 20 in. lbs. to pre-load bearing. (figure 36)

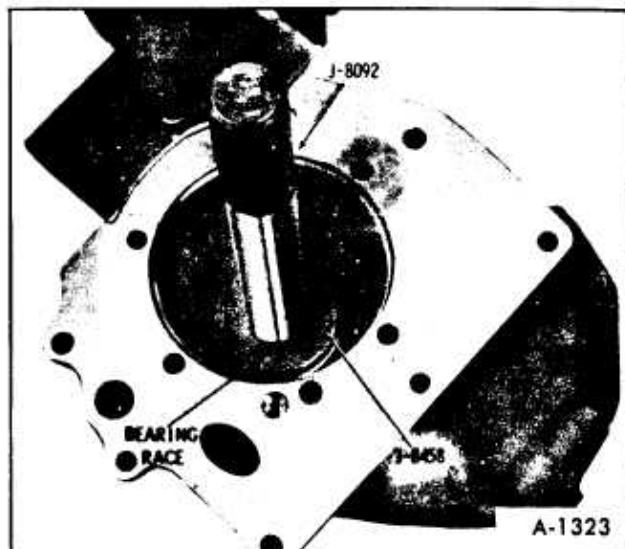

Figure 35—Installing Pinion Front Bearing Outer Race

4. Remove dial indicator post from Tool J-21777-1 and install Discs J-21777-22 as shown in Figure 37. Reinstall dial indicator post.

5. Place the gauging discs in the side bearing bores and install the side bearing caps. Torque cap bolts to 65 ft. lbs.

6. Position the dial indicator, J-8001 on the mounting post of the gauge shaft and with the contact rod OFF the gauging area of J-21777-10. Set dial indicator on ZERO, then depress the dial indicator until the needle rotates 3/4 turn clockwise. Tighten the dial indicator in this position. RESET DIAL INDICATOR ON ZERO.

7. Position the gauge shaft assembly in the housing so that the dial indicator contact rod is directly

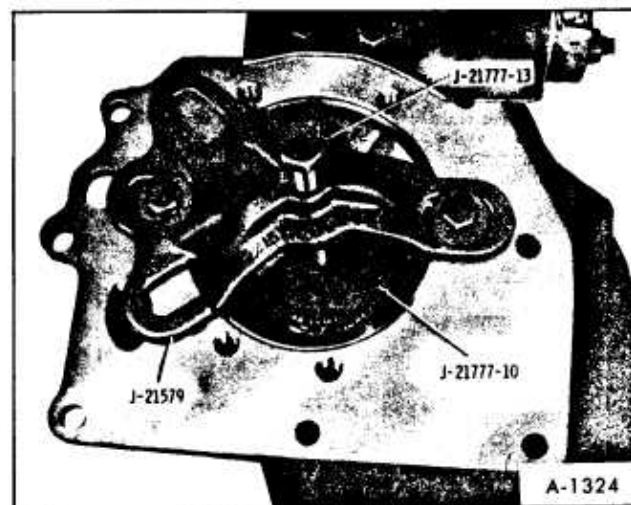

Figure 36—Pre-Loading Pinion Front Bearing

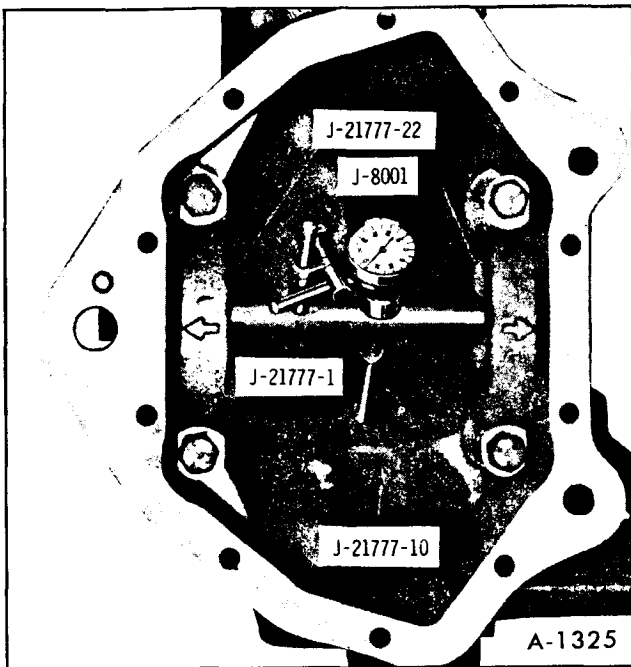

Figure 37—Pinion Depth Gauge Tool Installation

in line with the gauging area BUT NOT ON and the discs seated fully in the side bearing bores.

8. Rotate the gauge shaft assembly until the dial indicator rod contacts the gauging area of J-21777-10. Rotate gauge shaft slowly back and forth until the dial indicator reads the greatest deflection.

9. At the point of greatest deflection, read the dial indicator directly for pinion depth.

10. Select the correct pinion shim to be used during pinion reassembly on the following basis:

a. If a service gear set or a production gear set with no paint marking, on outer circumference of ring gear is being used, the correct shim will have a thickness equal to the indicator gauge reading found in Step 9. (figure 38)

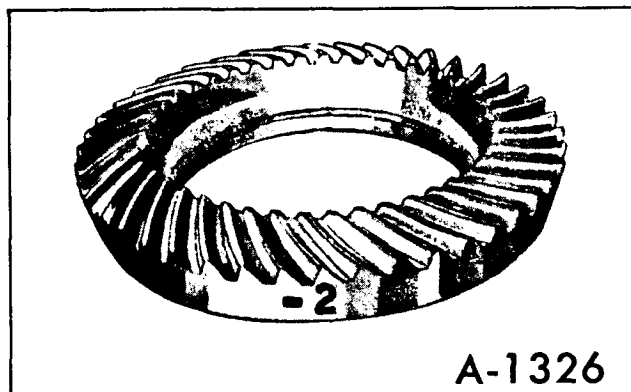

Figure 38—Location of Pinion Marking

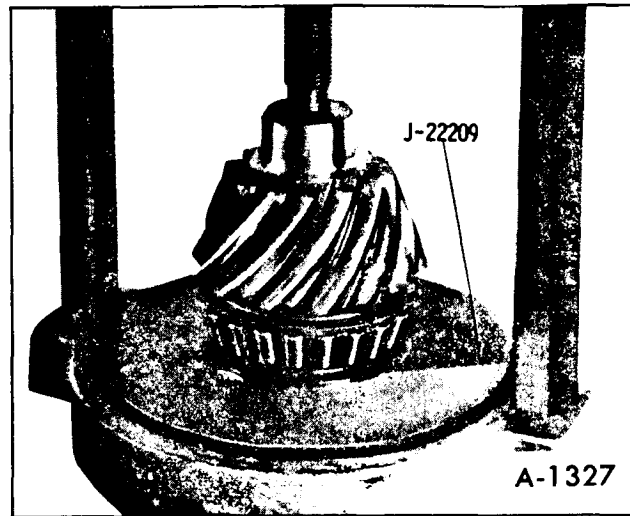

Figure 39—Installing Pinion Rear Bearing

b. If the gear set being used is painted “+” or “-”, the correct shim will be determined as follows.

Ring gear painted “+” (plus), the shim thickness indicated by the dial indicator on the pinion setting gauge must be **INCREASED** by the amount painted on the ring gear. (figure 38)

Ring gear painted “-” (minus), the shim thickness indicated by the dial indicator on the pinion setting gauge must be **DECREASED** by the amount painted on the ring gear. (figure 38)

11. Remove pinion depth checking tools and front bearing from housing.

12. Install rear pinion bearing as shown in Figure 39.

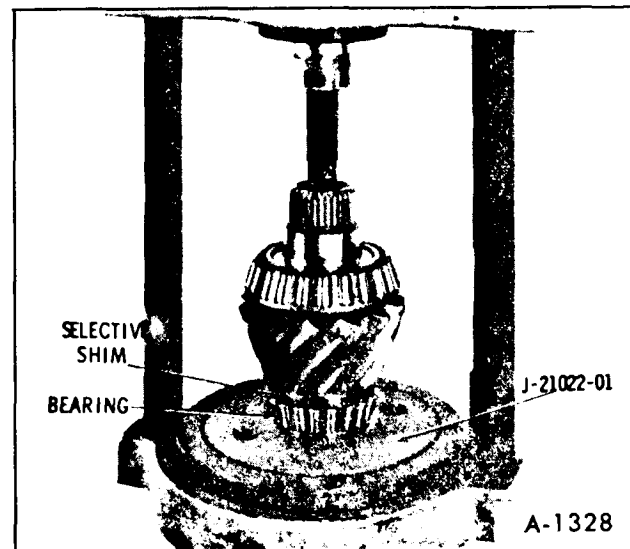

Figure 40—Installing Pinion Front Bearing And Shim

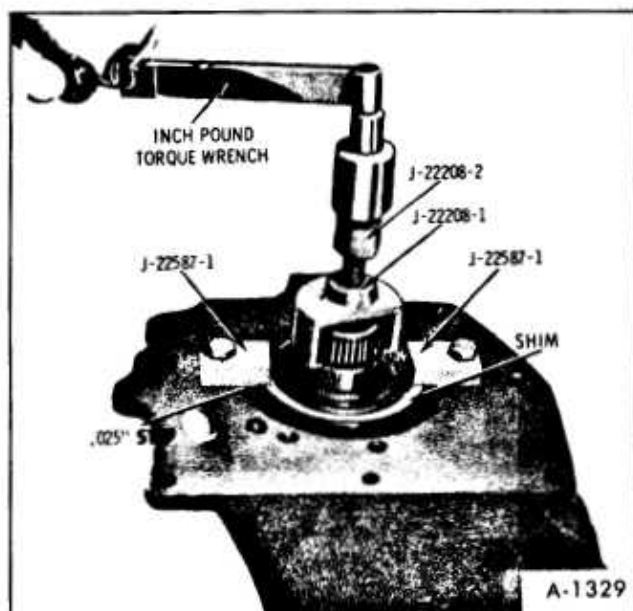

Figure 41—Checking Shim Thickness for Pinion Bearing

**NOTE:** Shims are available from .040" to .070" in increments of .002".

13. Position correct shim on drive pinion and install the drive pinion front bearing as shown in Figure 40.

## PINION BEARING PRE-LOAD ADJUSTMENT

1. The pre-load shim will have to be changed or checked any time the following parts have been replaced:

- a. Ring gear and pinion.
- b. Pinion bearings (front or rear).
- c. Rear bearing retainer.
- d. Final drive housing.

2. Position pinion bearing race on pinion bearing and install Tool J-22587-1 as shown in Figure 41. Using a feeler gauge check thickness between bearing race and Tool J-22587-1. Loosen bolts holding Tool J-22587-1 so that pinion bearing shim can be installed. Shims are available in sizes from .036" to .070" in increments of .002". Add shims until a pre-load of 2 to 5 in. lbs. for used bearings, 2 to 15 in. lbs. for new bearings is obtained. **RECORD FINAL SHIM THICKNESS.**

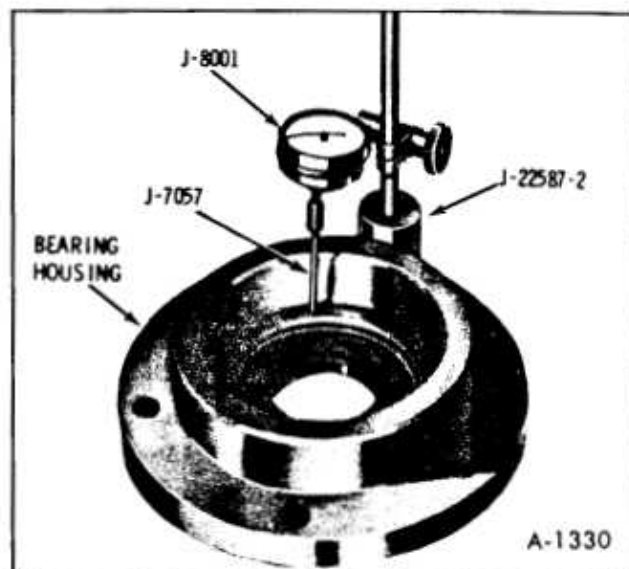

Figure 42—Checking Inner Flange Of Housing

3. Remove Tool J-22587-1.

4. With dial indicator J-8001 and extension J-7057, attach existing dial indicator post to Tool J-22587-2. (figure 42) While holding contact studs (three) of Tool J-22587-2 firmly against shoulder of bearing housing, position dial indicator as shown in Figure 42 and rotate dial to ZERO.

5. Carefully lift dial indicator assembly over flange of bearing housing and position assembly as shown in Figure 43. With the three contact studs held firmly against shoulder of bearing housing, rear the dial indicator deflection. **RECORD THIS DEFLECTION.**

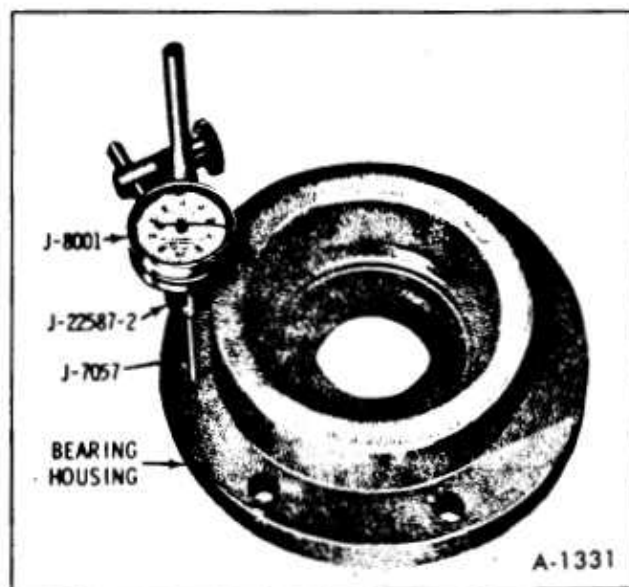

Figure 43—Checking Outer Flange Of Housing

The following is an example of finding the correct pinion bearing pre-load with information obtained above.

(Shims recorded in Step 2) .....	.053"
(Diff. in housing - Step 5).....	+ .024"
.....	.077"
(Built in step in Tool J-22587-1) .....	-.025"
.....	.052"
(To compensate for increase in pre-load when installing housing).....	-.002"
(Actual pinion bearing pre-load shim required).....	.050"

6. Position shim into bearing housing and install pinion rear bearing outer race as shown in Figure 44.

7. Install seals into bearing housing as shown in Figure 45.

8. Install a new "O" ring seal on the bearing housing.

9. Install seal and vent pin on face of housing. (figure 25)

10. Install seal protector J-22236 over drive pinion and install bearing housing over seal protector and position on the final drive housing. Torque the attaching bolts to 35 ft. lbs. (figure 46). Remove Tool J-22236.

**CAUTION:** Seal protector must be used or inner seal lip will fold between seal case and pinion shaft resulting in a leak.

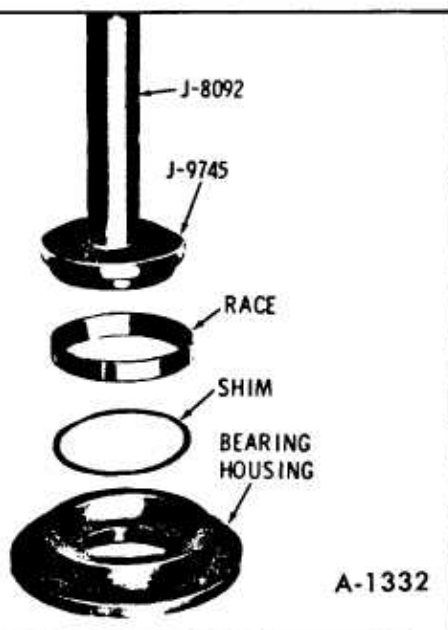

Figure 44—Installing Pinion Rear Bearing Outer Race

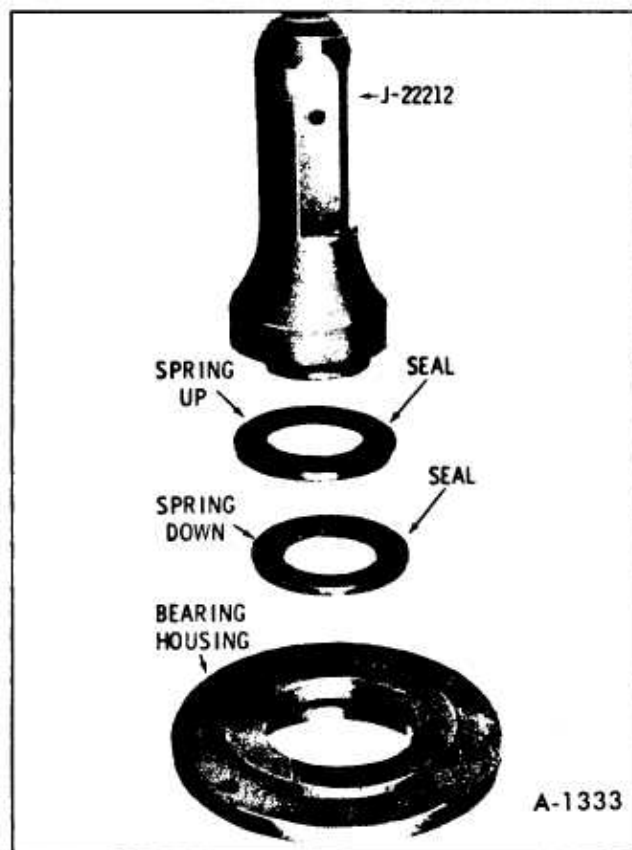

Figure 45—Installing Seals Into Bearing Housing

11. Reinstall Tool J-22208-1-2 and recheck pinion pre-load. Must be 2 to 5 in. lbs. for used bearings, 2 to 15 in. lbs. for new bearings (figure 23)

## CASE ASSEMBLY

### Side Bearing Installation

1. Install the side bearings as shown in Figures 47 and 48. Drive evenly until seated.

**NOTE:** Do not let the bearing cock as it is being driven on. Excess metal could be wiped off the mounting surfaces and the bearing could become loose on the case.

### SIDE AND PINION GEARS

#### Installation

Before assembling the differential case, lubricate all parts with Lubricant No. 1051022 or equivalent.

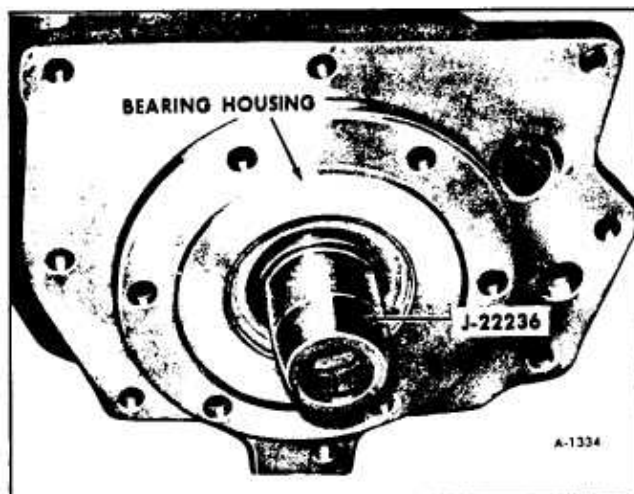

Figure 46—Installing Bearing Housing Into Final Drive Housing

1. Place side gear thrust washers over side gear hubs and install side gears in case. If same parts are reused, install in original sides.

**NOTE:** Position side gear with threaded rotainer on left side of case.

2. Position one pinion (without shims) between side gears and rotate gears until pinion is directly opposite from loading opening in case. Place other pinion between side gears so that pinion shaft holes are in line; then rotate gears to make sure holes in pinions will line up with holes in case.

3. If holes line up, rotate pinions back toward loading opening just enough to permit sliding in pinion gear shims.

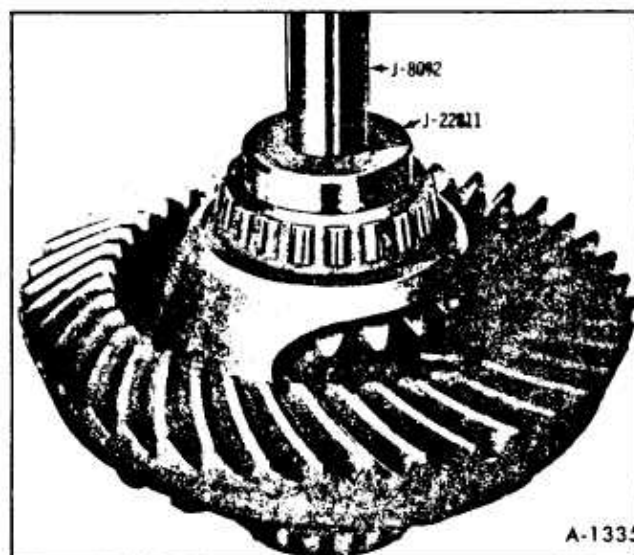

Figure 47—Installing Left Side Bearing

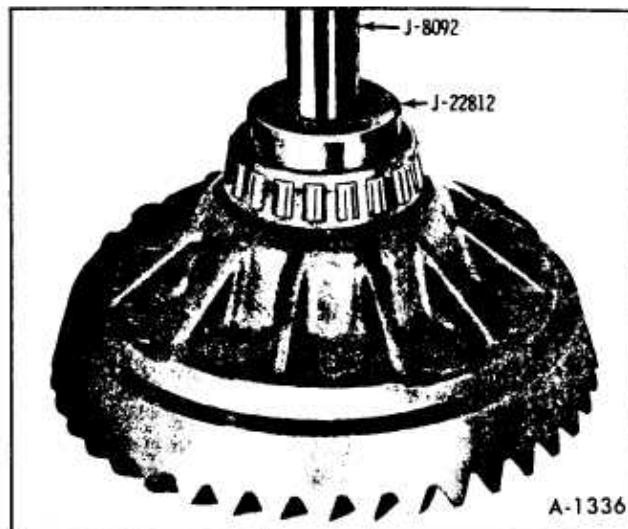

Figure 48—Installing Right Side Bearing

4. Install pinion shaft. Drive pinion shaft retaining lock pin into position. (figure 49)

## RING GEAR

### Installation

1. After making certain that, mating surfaces of case and ring gear are clean and free of burrs, install three (3) 7/16-20 x 1-3/4 bolts as shown in Figure 50 to correctly position ring gear.

2. Install Tool J-22822 into a vise and place case assembly over tool as shown in Figure 51. Install

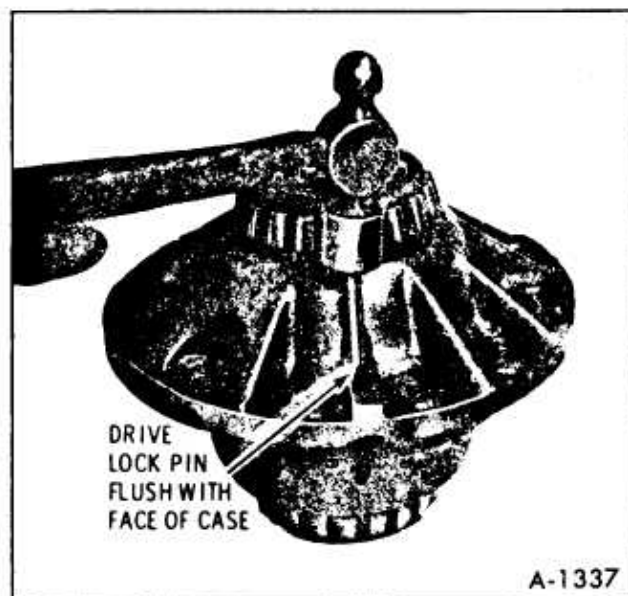

Figure 49—Installing Lock Pin



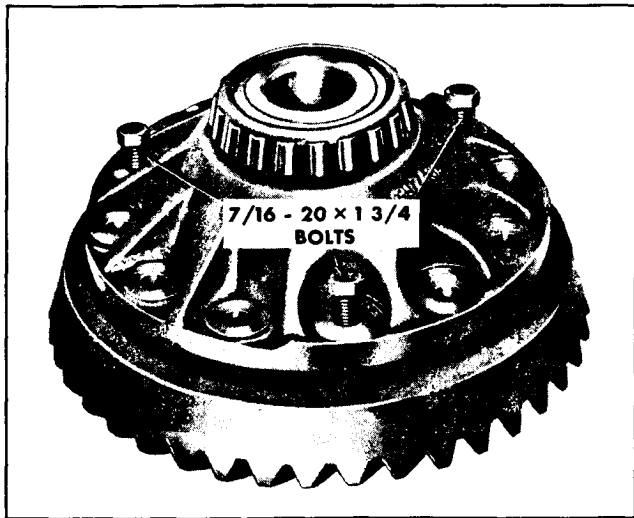

Figure 50—Installing Ring Gear to Case

NEW ring gear attaching bolts in remaining holes and then remove three (3) 7/16-20 x 1-3/4 bolts. Install remaining three NEW bolts into ring gear and torque bolts alternately in progressive stages to 85 ft. lbs.

**NOTE:** Tool J-22822 must be used to correctly torque ring gear bolts.

## SIDE BEARING PRE-LOAD ADJUSTMENT

Differential side bearing pre-load is adjusted by means of shims placed between the side bearing and housing. Shims are used on both sides and 19 shims are available in increments of .002" from .038" to .074". Two spacers .140"  $\pm$ .005", are used one on the right side and one on the left side. By adding or subtracting the same amount of shims from both

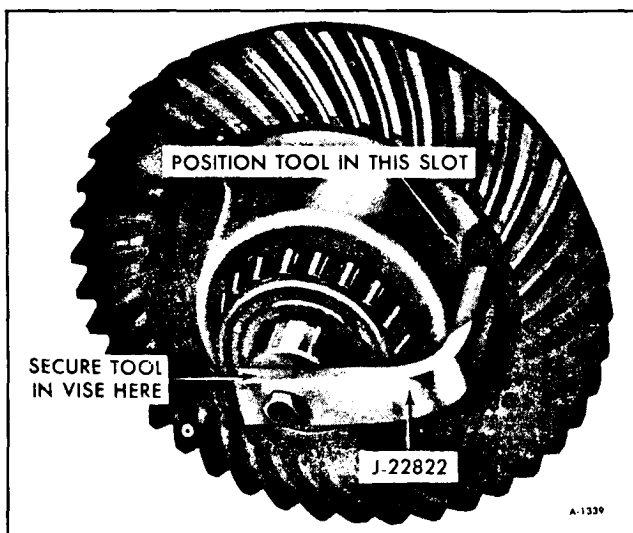

Figure 51—Installing Tool J-22822

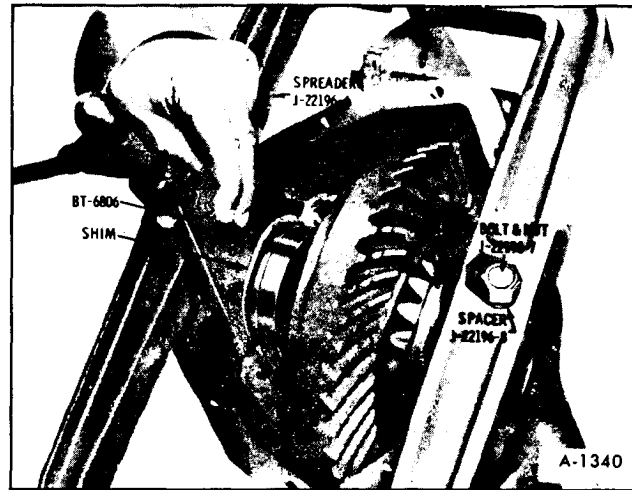

Figure 52—Spreading Housing For Shim Installation

sides, the ring gear to pinion backlash will not change.

1. Before installing the case assembly, make sure that side bearing surfaces in the housing are clean and free of burrs. Side bearings must be oiled with Lubricant No. 1051022 or equivalent. Turn fixture and housing so cover side is up.

2. Place differential case and bearing assemblies in position in housing.

3. Install the original spacers on left and right side. If the recorded side bearing pre-load was correct on disassembly, the original shims may be used.

4. Install Spreader J-22196 on housing and spread housing just enough so that shim can be inserted between the spacer and the housing. (figure 52)

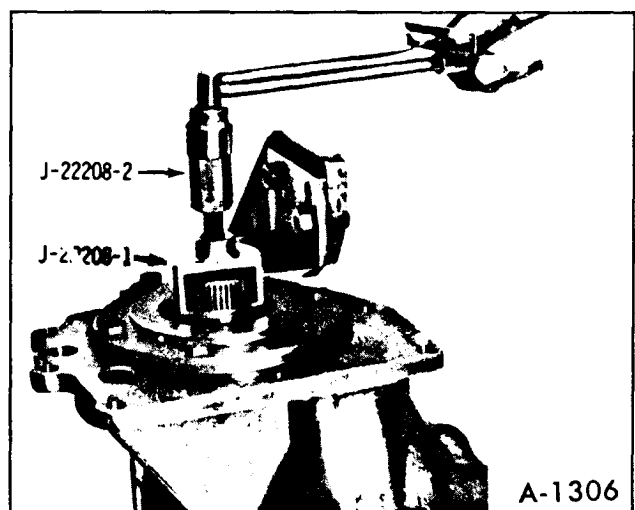

Figure 53—Checking Pinion And Side Bearing Pre-Load

5. Release tension on spreader tool install side bearing caps, and torque cap bolts to 65 ft. lbs., then check pre-load as shown in Figure 53. Pre-load should be 10 to 15 in. lbs. for new bearings, 5 to 7 in. lbs. for old bearings over the pinion bearing pre-load.

6. If pre-load is not within specifications, obtain proper combination of shims, either thicker or thinner, until side bearing pre-load is 10 to 15 in. lbs. for new bearings, 5 to 7 in. lbs. for old bearings over the pinion bearing pre-load.

## BACKLASH ADJUSTMENT

1. Rotate differential case several times to seat bearings, then mount dial indicator as shown in Figure 54. Use a small button on the indicator stem so that contact can be made near heel end of tooth. Set dial indicator so that stem is in line as nearly as possible with gear rotation and perpendicular to tooth angle for accurate backlash reading.

2. Check backlash at three or four points around ring gear. Lash must not vary over .002" around ring gear.

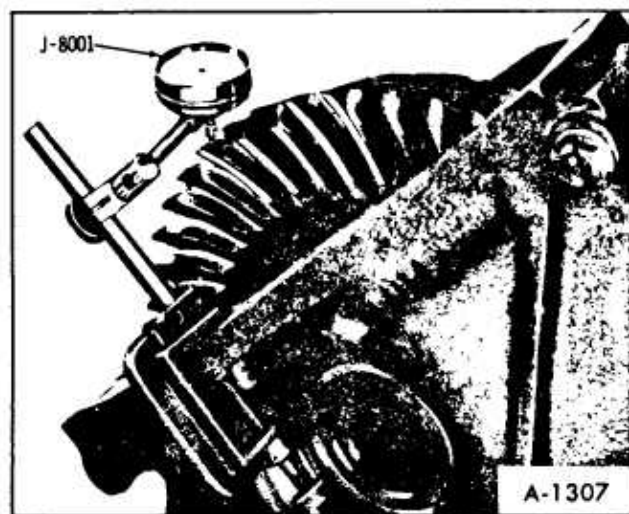

Figure 54—Checking Ring Gear To Pinion Gear Backlash

**NOTE:** Pinion must be held stationary when checking backlash. If variation is over .002" check for burrs, uneven bolting conditions or distorted case and make corrections as necessary.

3. Backlash at the point of minimum lash should be between .005" and .009" for all new gears. If original ring gear and pinion was installed, backlash should be set at the same reading obtained in Step 4 of the Final Drive Disassembly procedure, provided reading was within specifications.

4. If backlash is not within specifications, correct by increasing thickness of one differential shim and decreasing thickness of other shim the same amount. This will maintain correct differential side bearing pre-load.

For each .001" change in backlash desired, transfer .002" in shim thickness. To decrease backlash .001" INCREASE thickness of right shim .002" and DECREASE thickness of left .002". To increase backlash .002" DECREASE thickness of right shim .004" and INCREASE thickness of left shim .004".

5. When backlash is correctly adjusted, remove spreader. Install the bearing caps and bolts. Torque to 65 ft. lbs.

6. Install new output shaft seals as shown in Figure 10 and 14.

**NOTE:** Left output shaft seal is installed with vent hole toward top of final drive housing in the in-car position.

7. Install new gasket on housing. Install cover, torque cover bolts to 25 ft. lbs.

Fill final drive with fluid to "FILL LEVEL" line stamped on cover near fill hole.

Use only Gear Lubricant No. 1051022 or equivalent.

**NOTE:** If final drive was removed without removing the transmission, do not install gasket, cover or lubricant until final drive has been installed in Motor Home.



GMC

MOTOR  
HOME

SERVICE

# SECTION 4

## REAR SUSPENSION

Contents of this section are listed below:

SUBJECT	PAGE NO.
System Description .....	4-1
Trouble Diagnosis .....	4-4
Rear Suspension Trouble Diagnosis Chart.....	4-5
Component Removal.....	4-6
Compressor Overhaul .....	4-12
Height Control Valve Overhaul .....	4-15
Component Installation.....	4-20
On-Vehicle Adjustments .....	4-25
Periodic Maintenance .....	4-27
Rear Suspension Torque Specifications .....	4-28

## SYSTEM DESCRIPTION

### AIR BELLOWS

The rear suspension system (figure 1) on the vehicle consists mainly of air bellows, height control valves, control arms, and shock absorbers. The system operates automatically as load varies, to retain frame at proper ride height.

The air bellows are mounted between the control arms, for the tandem rear wheels. On each side of the air bellows is a piston which is connected direct to the control arm.

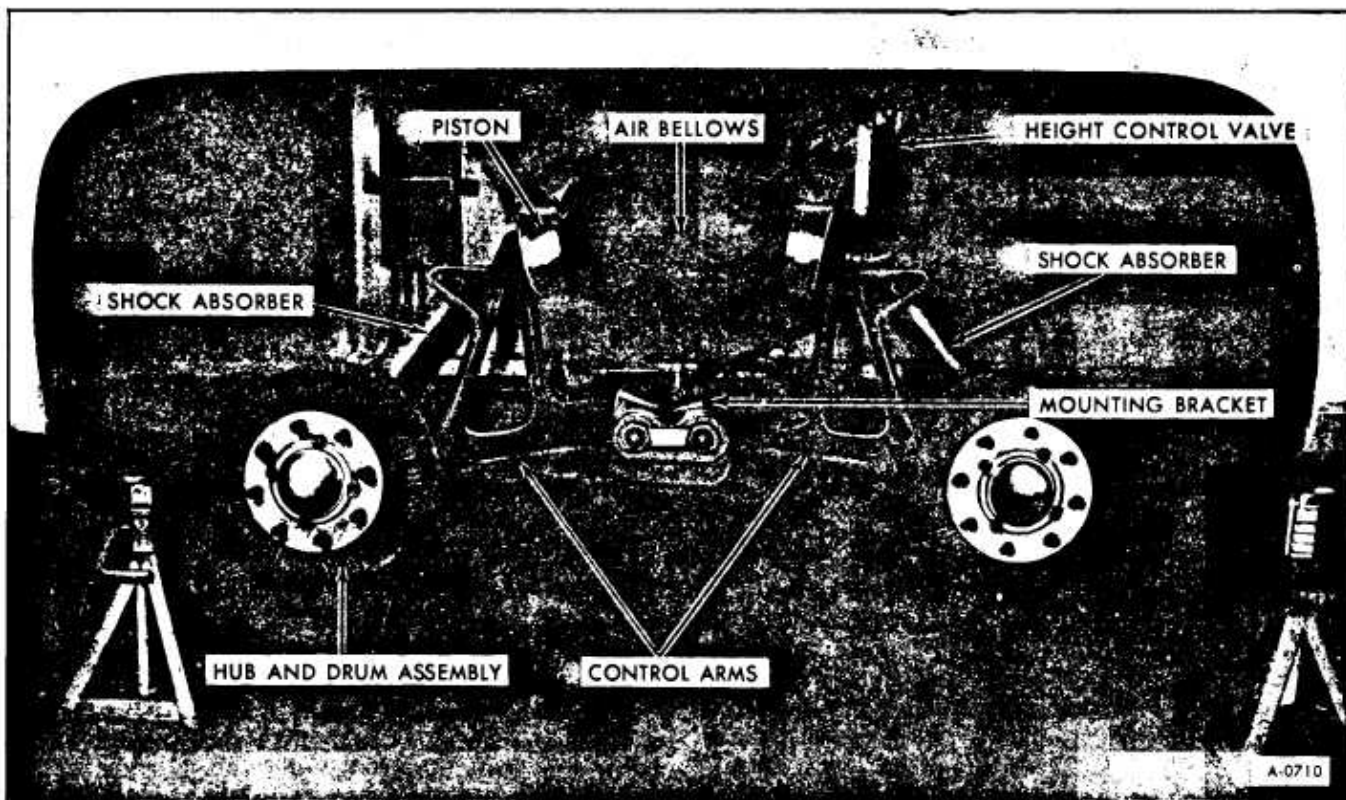

Figure 1—Rear Suspension (Left-Side View)

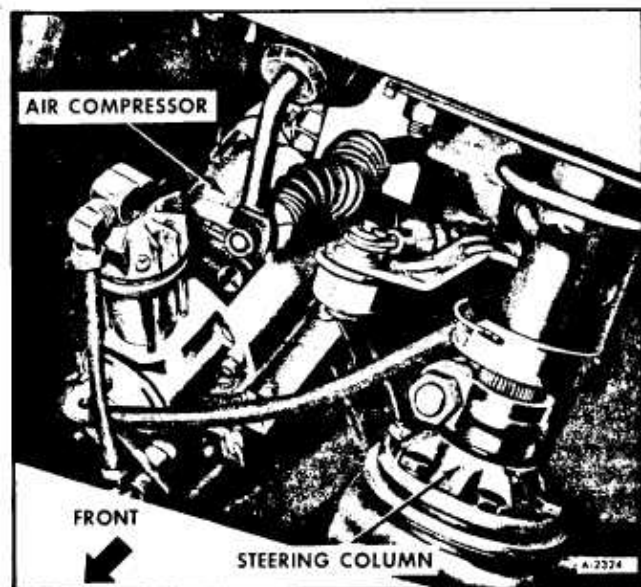

Figure 2-Air Compressor Location

## AIR COMPRESSOR

Compressed air for the system is supplied by a electric compressor which operates when the ignition key is in the "ON" or "ACCESSORY" position. It is a demand-type compressor which will start compressing air when the pressure in the system drops below 100 psi, and will shut off when the pressure reaches 120 psi. Air compressor for the system is located behind the left-front access door.

## AIR RESERVOIR

The purpose of the air reservoir is to provide a place to store compressed air for the rear suspension. The reservoir is located on the right-hand side of the motor home in front of the front wheel. The reservoir will allow the rear suspension to adjust without the air compressor operating.

Another purpose of the reservoir is to provide a place where the air, heated during compression, can cool and the water vapor can condense. Drain reservoir monthly.

## AIR BELLOWS

The air bellows serve as a flexible connection between the two control arms on each side of suspension bracket. The flexing of the air bellows allows the control arms to move up and down in relation to the frame. This action absorbs road shocks in the same manner as an inflated rubber tire cushions shock caused by road roughness.

## SHOCK ABSORBERS

A double acting shock absorber is used at each wheel on the rear suspension. The shocks are mounted to the top of the control arms and to the frame at the bottom.

The shock absorbers are gas filled cell type shocks. They are filled with a calibrated amount of

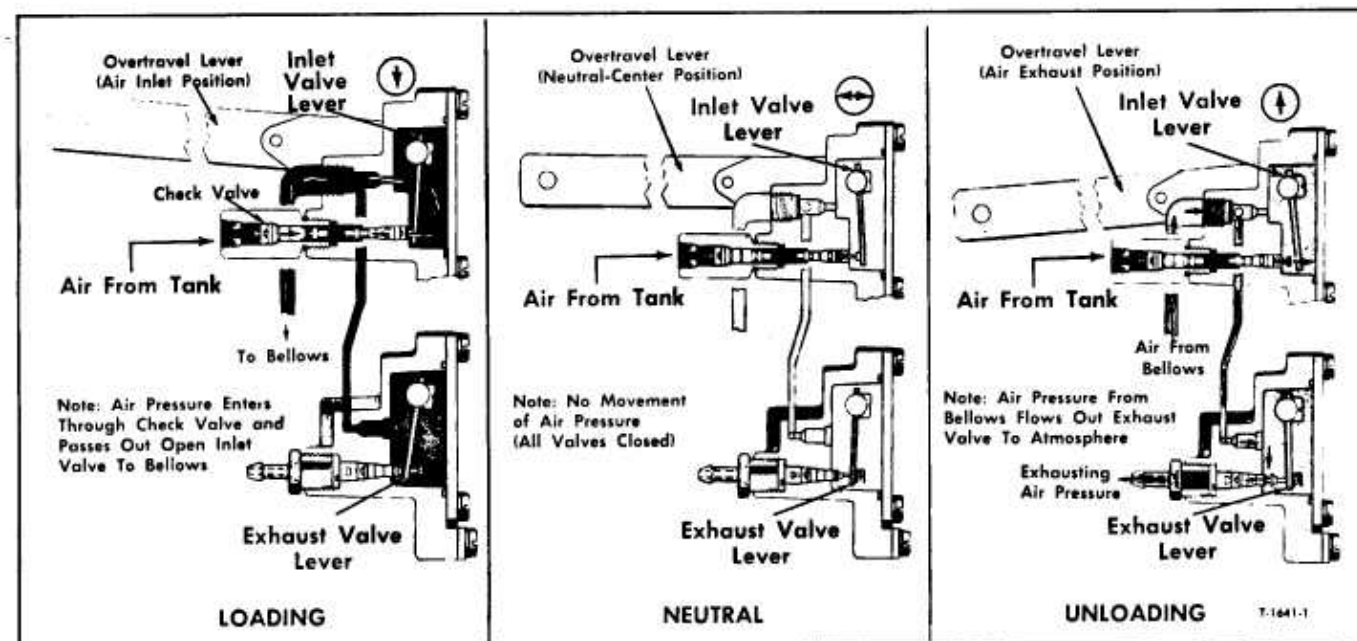

Figure 3-Operation of Height Control Valve

fluid and sealed during production. They are non-adjustable, non-refillable and cannot be disassembled the only service they require is replacement if they have lost their resistance, are damaged or leaking fluid.

## HEIGHT CONTROL VALVE

Height control valve automatically maintains a constant vehicle height by controlling the flow of compressed air into or out of suspension system air bellows. A delay piston in each valve provides a momentary delay in intake and exhaust valve action: therefore, air in bellows is exhausted only during load changes and not during intermittent road bumps.

The height control valve contains an intake valve, air bellows outlet, exhaust valve, delay piston, and overtravel control body. The overtravel control body contains a spring-loaded nylon piston which protects valve parts if overtravel lever is moved beyond normal operating range.

## HEIGHT CONTROL VALVE OPERATION

### Loading

When vehicle is being loaded, frame tends to settle. Since valve is linked to control arm, and valve is bolted to wheel well, valve moves downward with frame as vehicle is loaded. As valve arm and control shaft turns, a force is applied to the delay piston which moves slowly and allows the intake valve lever to move against the intake valve core. As pin is pushed in, air pressure flows through height control valve into bellows. Increased air pressure expands the bellows and raises frame.

Inlet valve is "PROTECTED" by check valve in inlet adapter. Light spring in core freely admits reservoir air, but return flow of air is blocked.

### Neutral Position

As increased air pressure expands bellows and lifts frame, the height control valve moves upward with frame. As frame is returning to normal ride height, valve arm and shaft return to a neutral position. Inlet valve lever also moves away from inlet valve core and inlet valve closes. This stops the flow of air into bellows. The exhaust valve remains closed.

Since the exhaust valve is closed, and the check valve in the inlet adapter prevents compressed air from returning to air reservoir, air is trapped in bellows and in valve. No further valve action or air pressure change takes place until load is increased or decreased, moving valve arm out of neutral position for four seconds or more to actuate intake valve or exhaust valve.

### Unloading

When part of load is removed, air pressure in bellows lifts frame. Valve arm, linked to axle, is pulled downward from neutral position. This applies a force on the delay piston, which moves it slowly. The exhaust valve lever moves with the delay piston. The outer end of exhaust valve lever fits around stem of exhaust valve core. As soon as lever moves beyond free-travel range, lever pulls on stem and opens exhaust valve. Inlet valve remains closed. Compressed air from bellows then flows through the open exhaust valve and out exhaust fitting to atmosphere. As the compressed air is exhausted from bellows, the frame lowers until overtravel lever and shaft are again in normal (neutral) position.

### Valve Arm Free Travel

With vehicle in motion and frame at normal ride height, control valve arm and shaft are in neutral position. Small irregularities in road causes slight up and down movement of valve arm. Clearances are provided between operating levers and cores of inlet and exhaust valves to permit 3/8-inch up or down movement of valve arm, from neutral position without causing valve action. This compensates for small road bumps. The bumps are absorbed by tires and bellows without causing movement of compressed air either into or out of suspension system.

### Hydraulic Delaying Action

Operation of delay piston in height control valve prevents change of bellows air pressure as a result of momentary road shocks, conserves air supply, and adds life to valve. The nylon piston moves inside cylinder containing a silicone type fluid. A flapper valve on either end of piston allows displacement of fluid or act as a check valve, depending on direction piston moves. Delay piston is moved by piston pin,

that is threaded into overtravel shaft. A 4 to 18 second delay results from the closing of one valve to the opening of other valve.

Overtravel piston is held against flat side of overtravel shaft by two springs inside piston. Piston keeps overtravel shaft in proper position relative to valve arm. Piston also allows valve arm to rotate through a complete circle, if necessary, without damaging parts inside valve.

## POWER LEVEL OPERATION

The power level option consists of two, in-line valves which override the height control valve. These valves allow the operator to raise or lower each side of the rear suspension from the driver's seat. This is accomplished by bypassing the height control valve and adding or expelling air directly from the bellows. For a diagram of air lines see figure 43.

## TROUBLE DIAGNOSIS

### AIR LEAKS

With the air system at normal operating pressure coat all suspension air line connections with soap and water solution. Air leakage will produce soap bubbles. No leakage is permissible. Leakage at air line connections can sometimes be stopped by tightening connection. If this does not stop the leak replace the affected fittings.

### SHOCK ABSORBERS

See Section 3A "FRONT SUSPENSION" for trouble diagnosis of shock absorbers.

### HEIGHT CONTROL VALVE AIR LEAKAGE CHECK

**NOTE:** Air leakage check can be performed for air line connections, only when valve is installed on vehicle. The following instructions explain procedure for performing air leakage check on valve when removed from vehicle.

1. Clean exterior of valve assembly.

2. Connect air pressure line to air inlet port, then open the air pressure (90-120 psi).

3. Submerge valve assembly in a container of water, then watch for air bubbles when the valve arm is in center (neutral) position. No air should escape from any point of valve assembly.

4. If bubbles appear from the bellows port, this is an indication the air inlet valve assembly is defective and must be replaced.

5. Remove air pressure line from air inlet fitting and connect it to the bellows port. If bubbles appear at the air inlet check valve port, this is an indication that check valve unit is defective and must be replaced.

6. If bubbles appear at the exhaust port it is an indication the exhaust valve assembly is defective and must be replaced.

7. If bubbles appear around edge of valve cover plate, the cover plate gasket must be replaced.

8. If no leaks are detected, remove valve assembly from water, then with air pressure still connected to bellows port, actuate valve arm to expel any water which may have entered exhaust valve chamber. Remove air line and connect it to air inlet port and repeat operation to remove water from air inlet valve chamber.



# REAR SUSPENSION TROUBLE DIGNOSIS CHART

Problem	Possible Cause	Correction
No air pressure in air reservoir-unit not operating.	1. Open circuit breaker.	1. Find cause of circuit breaker being "OPEN" and correct it. Circuit breaker is located behind the glove box door.
	2. Faulty wiring.	2. Check to see that wiring is intact.
	3. Low battery.	3. The compressor runs off the automotive battery, check its condition and correct as necessary.
	4. Faulty or pitted contacts on pressure switch.	4. Replace pressure switch.
	5. Motor has developed an open circuit.	5. Motor brushes or commutator worn out. Replace motor.
No air pressure in air reservoir-unit is operative.	1. Air leak in system.	1. Eliminate air leaks in system as explained earlier in this section.
	2. Compressor valve seat or valve spring worn or broken.	2. Replace valve seat and/or valve spring.
	3. Piston rings are worn-air leaks heavily by rings.	3. Replace piston rings.
	4. Pressure switch contacts are pitted causing improper compressor action.	4. Replace pressure switch. ↙
	5. Pressure switch not properly adjusted	5. Adjust pressure switch settings to operate at the 100-120 psi range. ↘

Problem	Possible Cause	Correction
Air pressure in tank-unit operating erratically-pump takes to long to pressurize tank.	1. Air leak in system.	1. Eliminate air leaks in system as described earlier in this section.
	2. Compressor valve seat valve broken or worn.	2. Replace valve seat and/or valve spring.
	3. Piston rings are worn-air leaks heavily by rings.	3. Replace piston rings.
	4. Pressure switch contact are pitted causing improper compressor action.	4. Replace pressure switch.
	5. Battery voltage to low to operate motor.	5. Charge battery.
	6. Bearing failure may cause unit to seize occasionally and break loose if galling occurs.	6. Replace bearings or parts with bearings.

## COMPONENT REMOVAL

**CAUTION:** Whenever it is necessary to support the rear suspension with jack stands or other supporting equipment, as shown in figure 1, be sure jack stands are used only at a junction point(s) of the frame rail and crossmember. Failure to locate jack stand as instructed could result in damage to frame of vehicle.

### PRESSURE SWITCH REMOVAL

1. Raise left front corner of vehicle.
2. Release pressure from reservoir through its drain tank.
3. Remove air line to compressor switch assembly. Remove wiring to compressor switch assembly.
4. Referring to Figure 4, Remove three bolts on vertical bracket to radiator mounting. (There are weldnuts on inside of radiator mounting.)
5. Remove two bolts and nuts from lower supporting bracket.

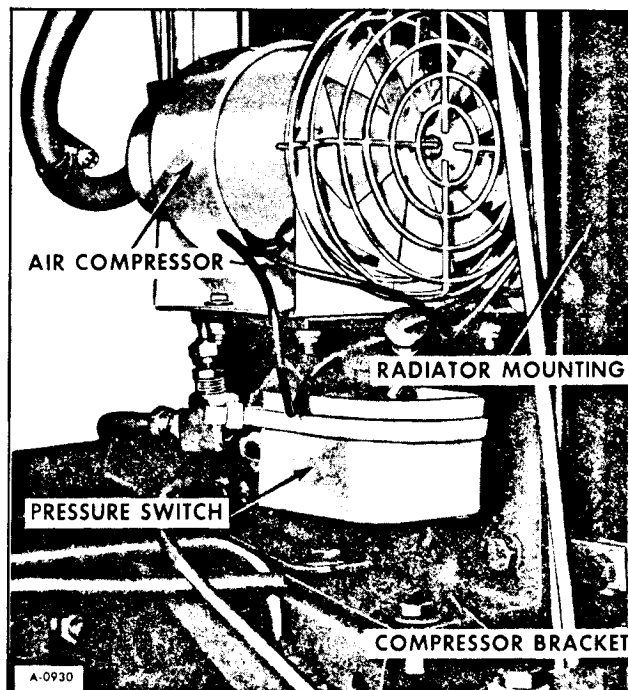

Figure 4—Air Compressor Installation

6. Remove compressor and pressure switch assembly.

7. With assembly on bench, disconnect motor lead in pressure switch, and ground wire from mounting bracket.

8. Referring to figure 4, remove four nuts and bolts from compressor mounting bracket.

9. Remove air compressor.

10. Pressure switch assembly can be removed by disconnecting fitting at mounting bracket.

## AIR RESERVOIR REMOVAL

1. Slowly open drain cock on reservoir (figure 5) to expel air.

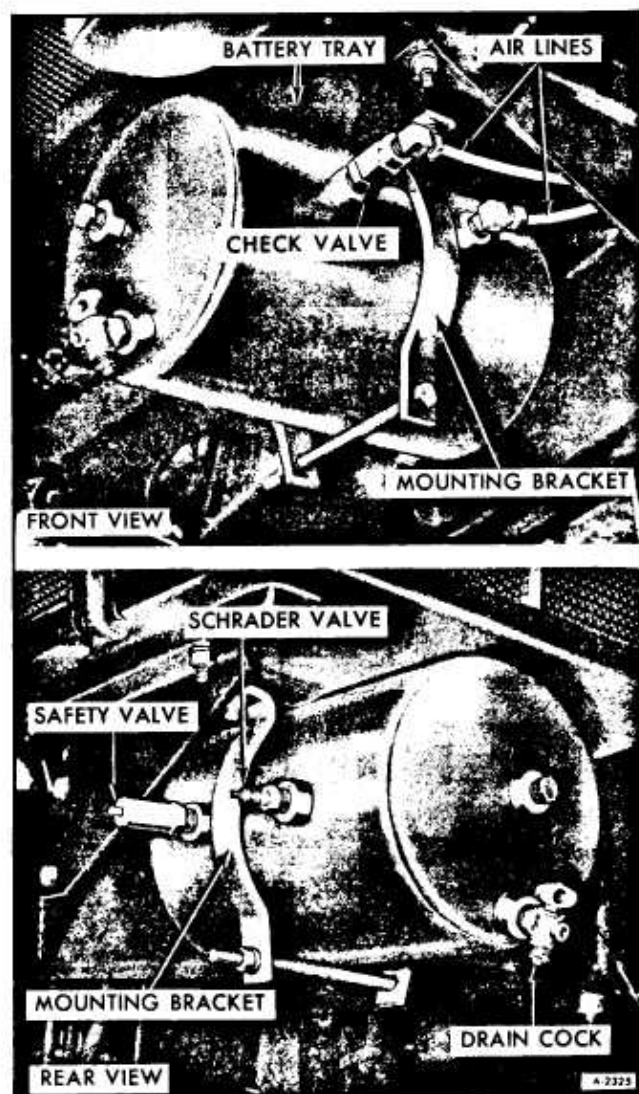

Figure 5—Air Reservoir

2. Remove the two air lines from the front of the reservoir.

3. Remove retaining nut and bolt from lower portion of bracket.

4. Remove reservoir.

5. Remove drain cock, safety valve, and schrader valve.

## HEIGHT CONTROL VALVE REMOVAL

Before disconnecting any height control valve air lines, securely support frame to prevent it from lowering as air is released from suspension. Exhaust air from air supply system by opening drain cock on air reservoir. After the above precautions have been taken, remove height control valve as follows:

1. Disconnect height control valve overtravel lever from valve link. Pull lever downward and hold several seconds to overcome time delay feature; This will release compressed air from bellows.

2. Referring to figure 6, disconnect air supply line and bellows air line from height control valve. Tape ends of lines to prevent foreign material from entering.

3. Remove two nuts attaching height control valve to wheel well and remove valve assembly.

## AIR BELLOWS REMOVAL

1. Support vehicle on jack stands.

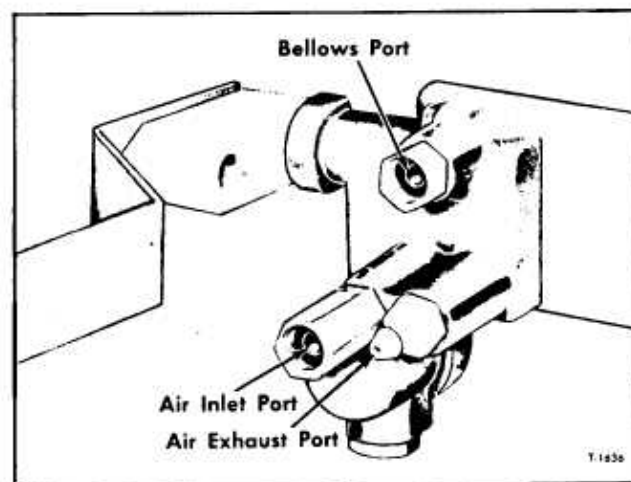

Figure 6—Height Control Valve Ports

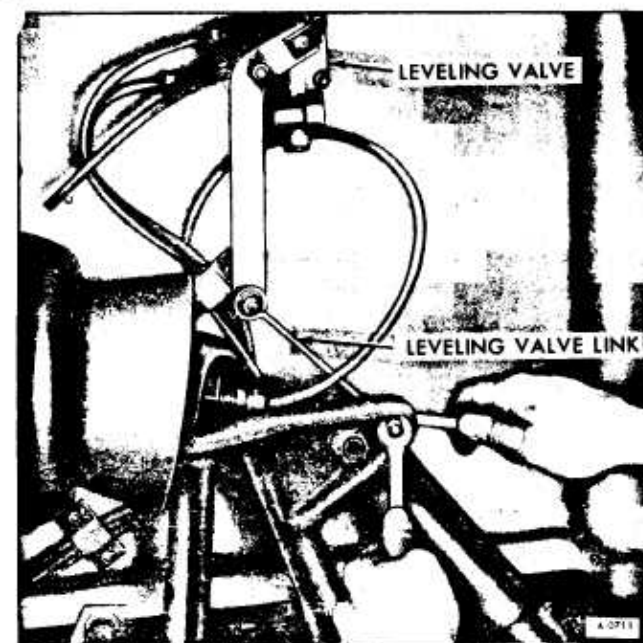

Figure 7—Disconnecting Height Control Valve Link

2. Referring to Figure 7, disconnect leveling valve link and move arm down to open exhaust valve and let air out of bellows.

3. Referring to Figure 8, disconnect air line to bellows.

4. Referring to Figure 9, remove retaining nuts and washers.

5. Remove air bellows from vehicle.



Figure 8—Disconnecting Bellows Air Line

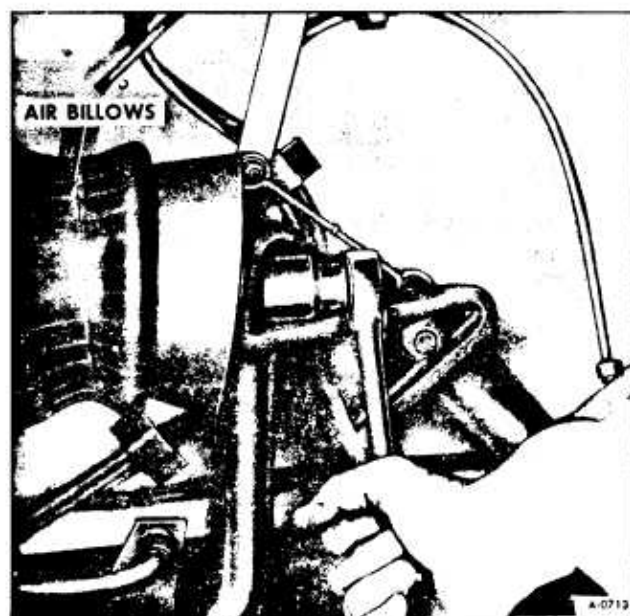

Figure 9—Removing Bellows Retaining Nut

## CONTROL ARM REMOVAL

1. Raise vehicle until rear wheels are off the floor.

2. Remove wheels.

3. Disconnect leveling valve link at control arm. Remove air from bellows by moving valve arm down. Disconnect air line at the bellows as shown in Figure 8.

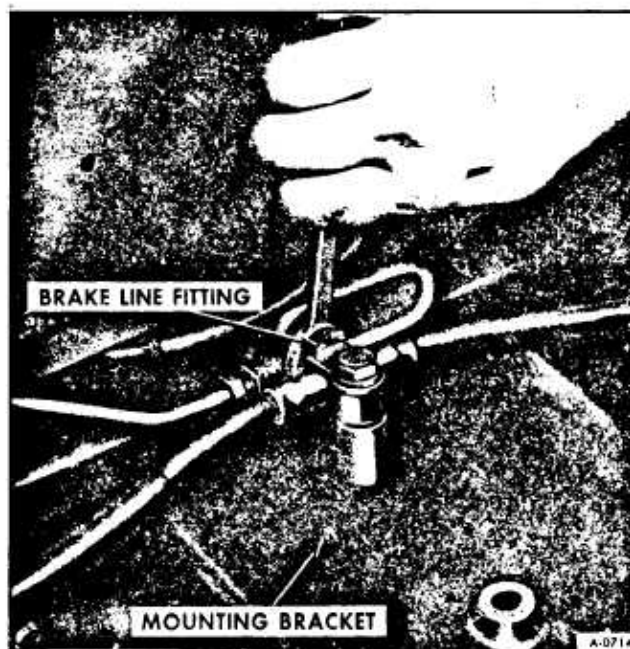

Figure 10—Disconnecting Brake Line



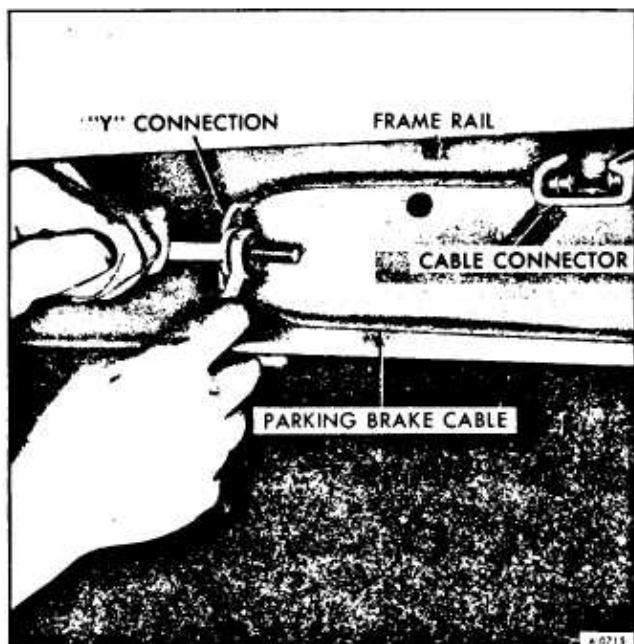

Figure 11—Disconnecting Parking Brake Cable

4. Remove bellows retaining nuts, located at either end of air bellows, as shown in Figure 9.

5. Disconnect shock absorbers from control arm mounting.

6. Referring to Figure 10, disconnect brake line at center mounting bracket and at each brake backing plate. Remove brake lines from control arms by unbolting all mounting points.



Figure 12—Dust Cap Removal

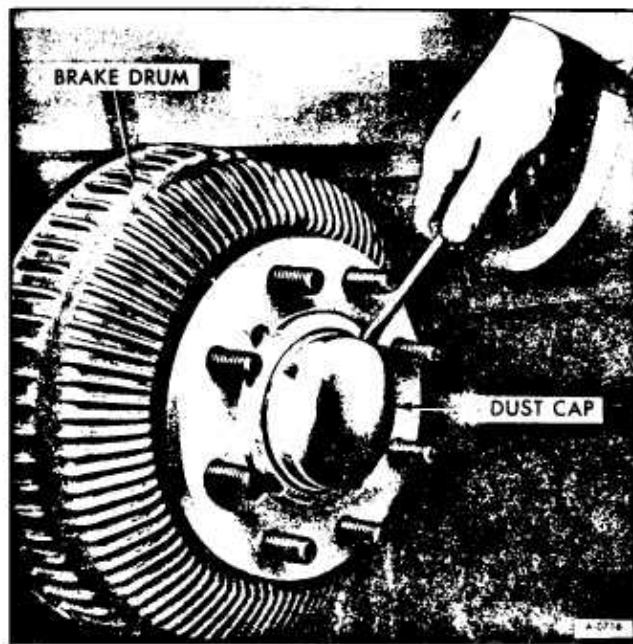

Figure 13—Castilated Nut Removal

7. Disconnect parking brake cable at "Y" connection as shown in Figure 11.

8. Remove brake drums, then—

A. Remove dust cap (figure 12)

B. Remove cotter pin castilated nut (figure 13).

C. Remove drum, hub, and bearings as a unit (figure 14).



Figure 14—Removing Hub and Drum

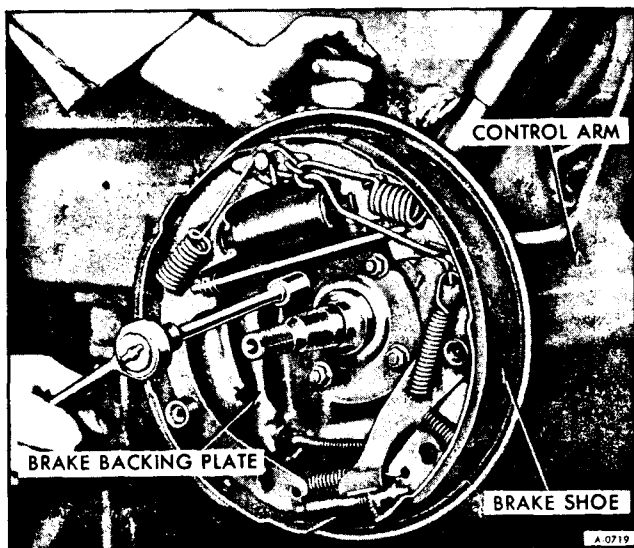

Figure 15—Removing Brake Backing Plate and Brake Shoe Assembly

9. Referring to Figure 15, remove four bolts and nuts retaining brake backing plate to control arm. Repeat procedure on opposite wheel.

10. Support mounting bracket with floor jack. Referring to Figure 16, remove two bolts holding mounting bracket to crossmember. Remove four bolts holding mounting bracket to frame rail.

11. Lower rear suspension unit to floor as shown in Figure 17.

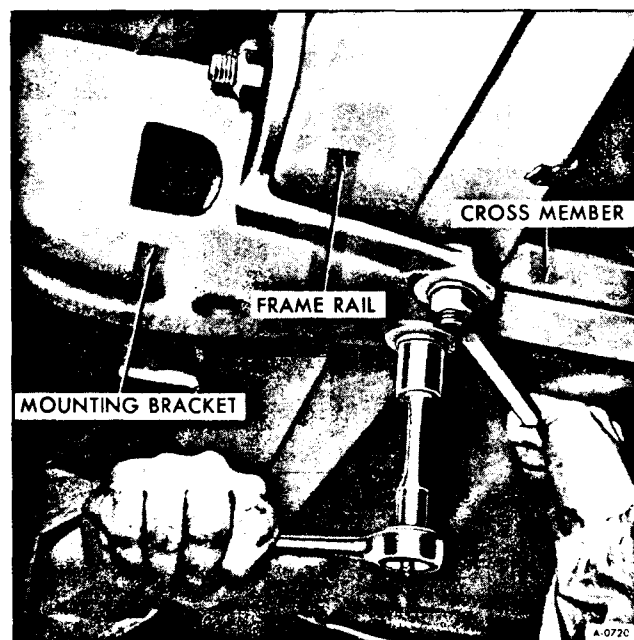

Figure 16—Removing Mounting Bracket Retaining Bolts

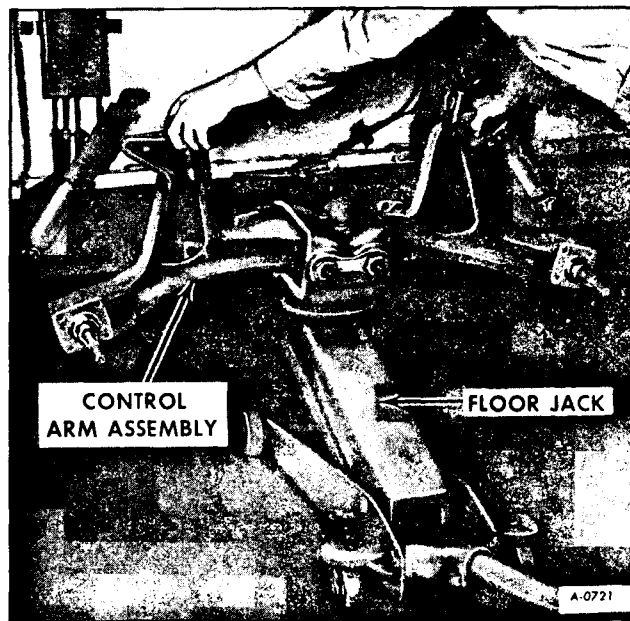

Figure 17—Lowering Control Arm Assembly from Vehicle

12. Referring to Figure 18, remove two nuts on mounting bracket. Remove Allen head retaining screws on back of mounting bracket as shown in Figure 19.

13. Press out control arm mounting pins, then remove control arms.

14. Press out spindles.

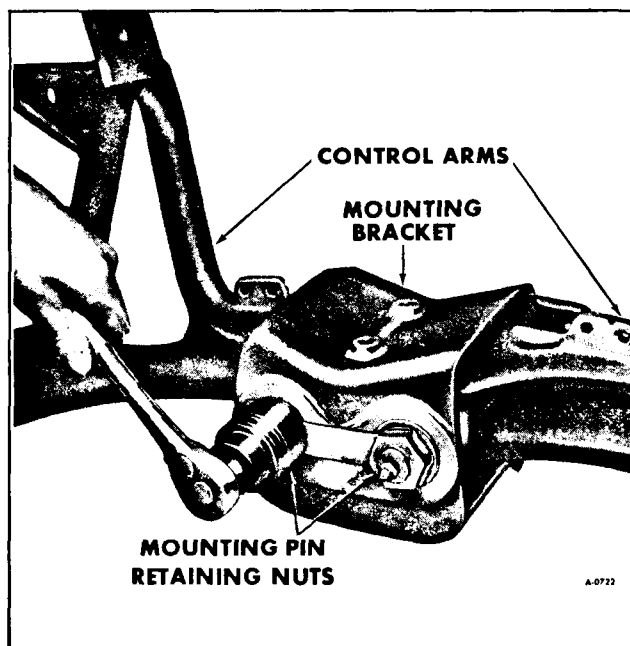

Figure 18—Removing Mounting Bracket Nuts

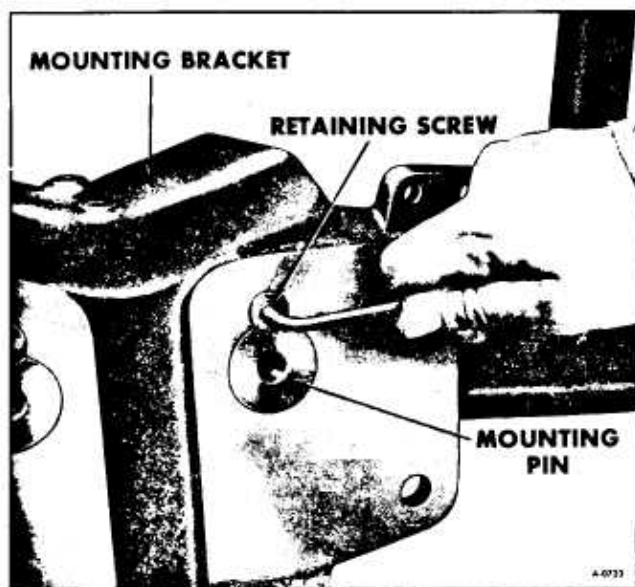

Figure 19—Removing Allen Head Retaining Screws

## SHOCK ABSORBER REMOVAL

Block control arms in an up position with a wooden block about one inch in thickness as shown in Figure 20.

Remove nut at top of shock absorber as shown in Figure 21, and remove shock from control arm. Remove nut from bottom of shock and remove shock from mounting bracket.

## POWER LEVEL VALVE REMOVAL

1. Bleed air from reservoir tank and place valve in lower position.

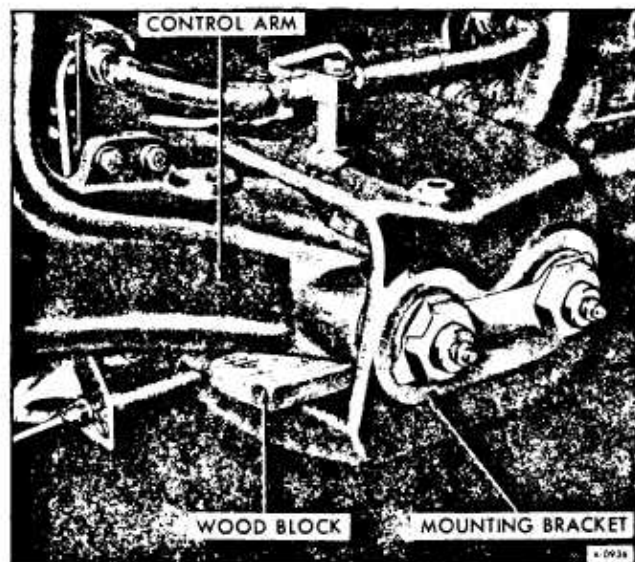

Figure 20—Positioning Wood Block Under Control Arm

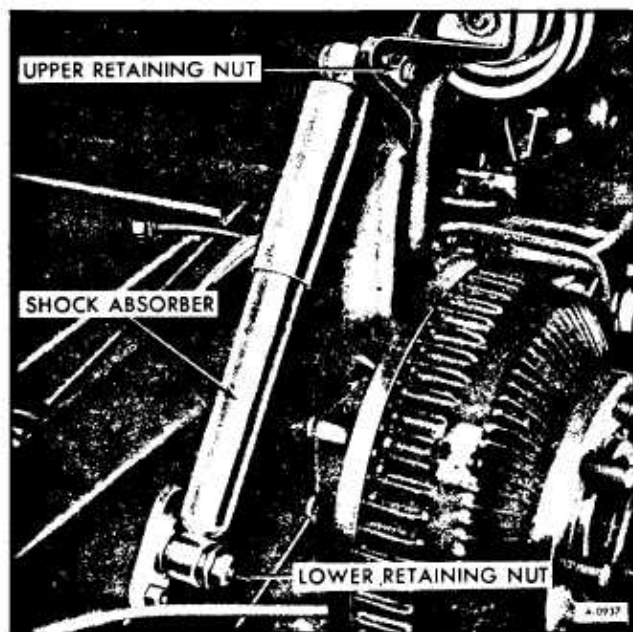

Figure 21—Removing Shock Absorber Retaining Nuts

2. Remove four screws on mounting panel.

3. Remove control knobs by removing Allen head screw in center of knobs (See figure 22).

4. Remove two screws holding each valve to mounting panel.

5. Disconnect three fitting from the back of each valve as shown in Figure 23 and remove valves.

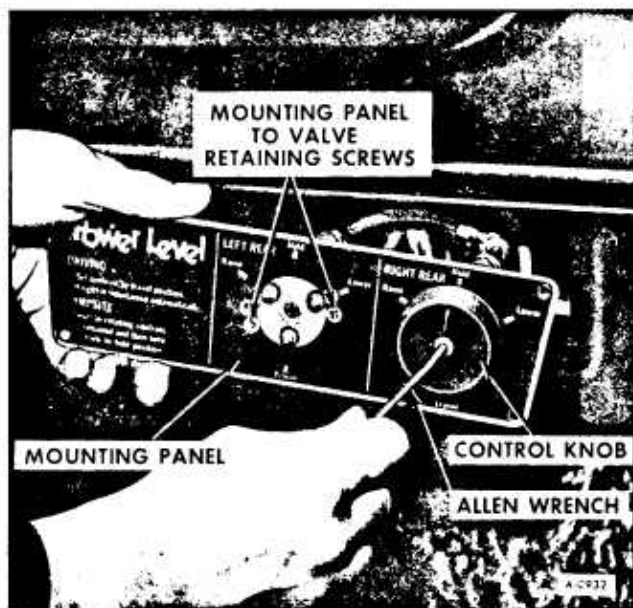

Figure 22—Removing Power Level Control Knobs and Panel

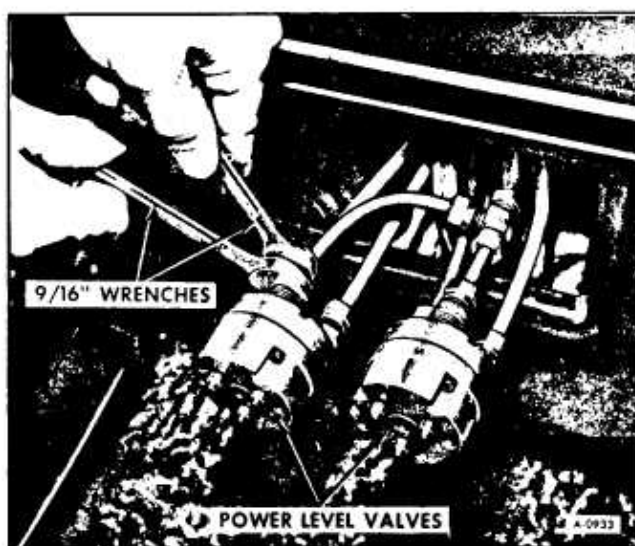

Figure 23—Removing Power Level Valve

## COMPRESSOR OVERHAUL

### PISTON RING REPLACEMENT

It is recommended that when the piston rings are replaced, the sleeve and expander rings be replaced also.

1. Remove compressor from vehicle.
2. Remove four screws from piston dome as shown in Figure 24. Remove piston dome and its gasket. Remove valve plate and its gasket.

3. Referring to Figure 25, remove piston sleeve.

4. Remove and replace piston rings and expanders.

**NOTE:** There is an expander located under each piston ring. The expander is an O-ring.

5. Install new piston sleeve.

6. Install valve plate and new gasket.

7. Install piston dome and new gasket, and retain in position with four screws.

### INTAKE VALVE REPLACEMENT

#### REMOVAL

1. Remove air compressor from vehicle.

2. Remove four screws from piston dome. Remove piston dome and its gasket, then remove valve plate and its gasket.

3. Remove piston sleeve.

4. Remove screw from valve on top of piston and remove valve.

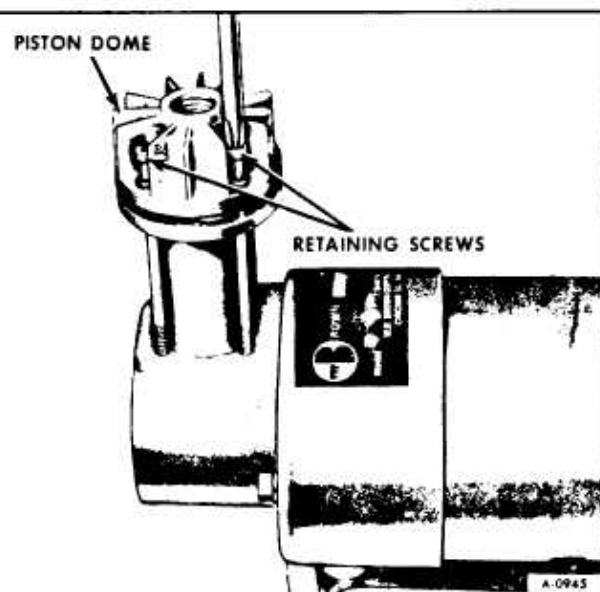

Figure 24—Removing Screws From Piston Dome

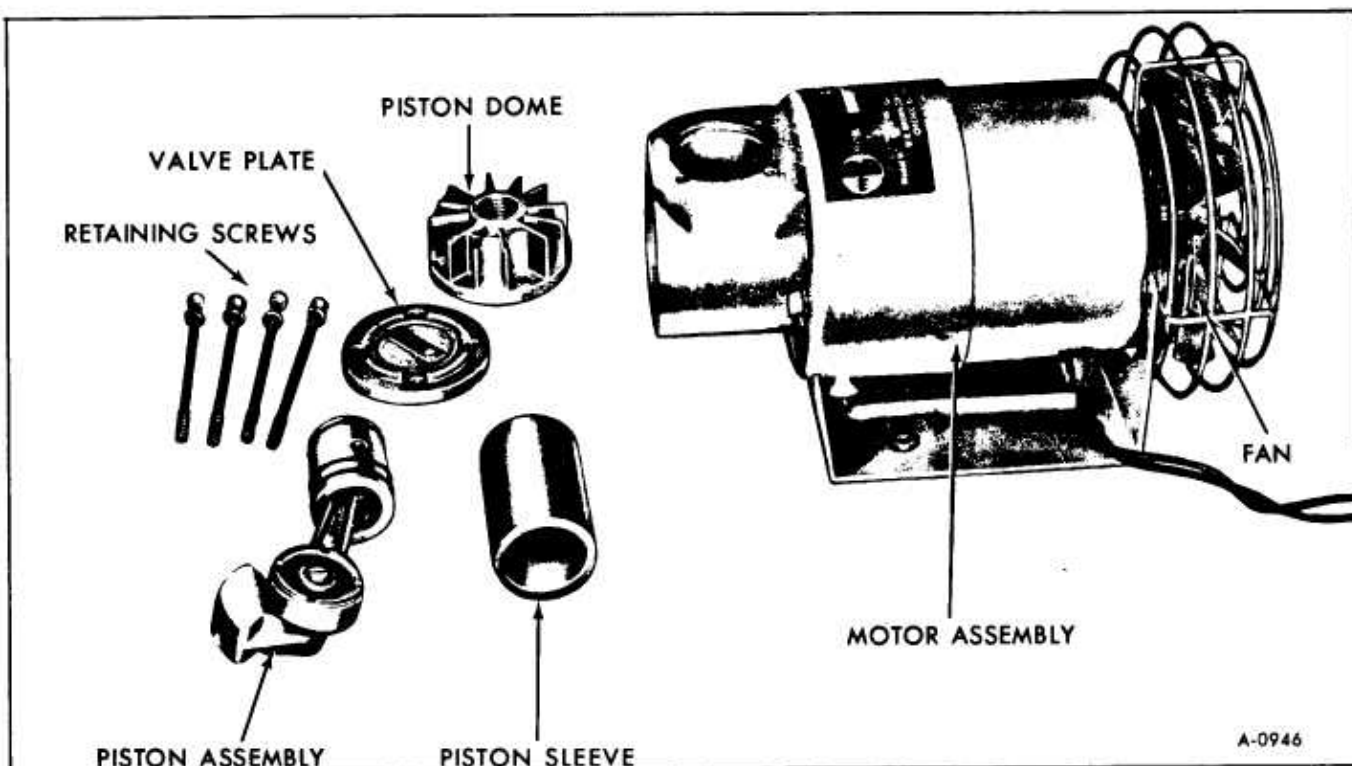

Figure 25-Compressor Components

## INSTALLATION

1. Install valve and screw retaining it on the piston.
2. Install piston sleeve.
3. Install valve plate and its gasket and install piston dome and its gasket. Install four screws in piston dome.

## INSTALLATION

1. Install "O" ring by first applying a small amount of silicone rubber cement or equivalent in recess for "O" ring. Then set "O" ring in place.

## EXHAUST VALVE REPLACEMENT REMOVAL

1. Remove air compressor from vehicle.
2. Remove four screws from piston dome. Remove piston dome and its gasket. Remove valve plate and its gasket.
3. Remove retaining screw from exhaust valve and remove valve as shown in Figure 26.
4. Remove "O" ring under valve.

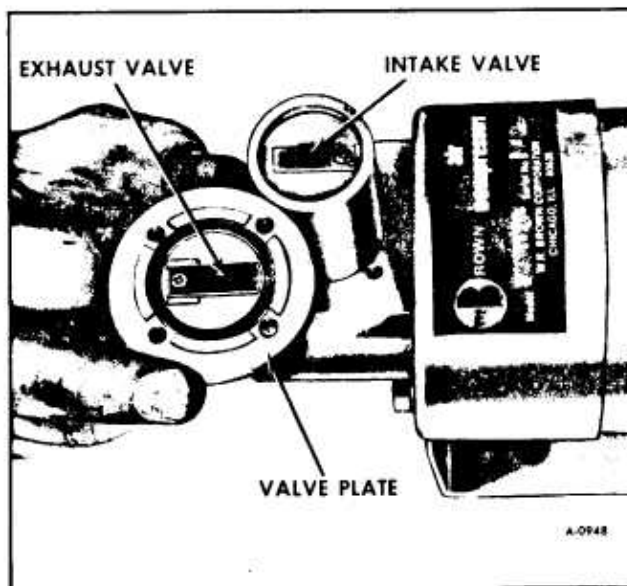

Figure 26-Removing Retaining Screw From Exhaust Valve



2. Install valve and retain in position on valve plate with screw.

3. Install valve plate and its gasket, and install piston dome and its gasket. Replace four screws in piston dome.

## PISTON REPLACEMENT

### REMOVAL

1. Remove air compressor from vehicle.
2. Remove four screws from piston dome. Remove piston dome and gasket. Remove valve plate and gasket.
3. Remove piston sleeve.
4. Remove air filter.
5. Rotate eccentric (figure 28) until piston is at the bottom of its stroke.

6. Referring to Figure 27, Loosen Allen head set screw which is at top of eccentric.

7. Remove eccentric from motor output shaft, and remove piston assembly through air filter opening as shown in Figure 28.

8. Remove piston rings and piston ring expanders.

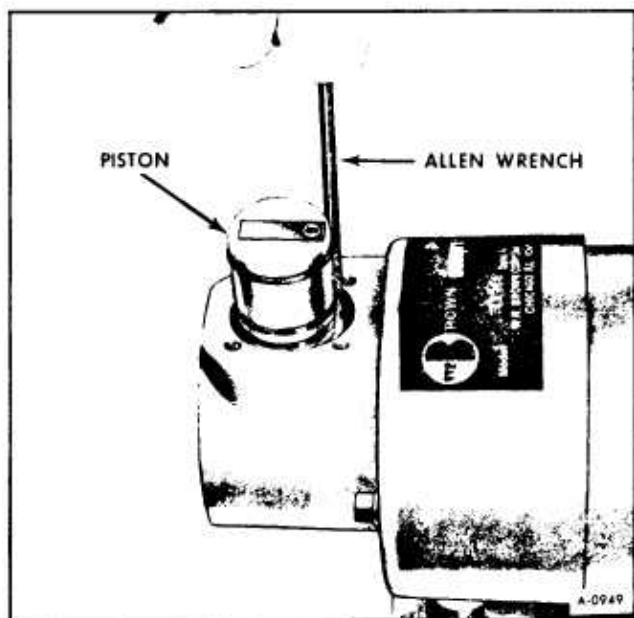

Figure 27—Loosening Allen Screw on Eccentric



Figure 28—Removing Compressor Piston

### INSTALLATION

1. Install piston rings and piston ring expanders.
2. Place piston assembly in position with eccentric on motor output shaft. The eccentric must be positioned to contact the bearing on the motor.
3. Tighten Allen Head set screw on eccentric to at least 5 ft. lbs. torque.
4. Install piston sleeve.
5. Install valve plate and gasket, and install piston dome and gasket.
6. Install four screws in piston dome.
7. Install air filter.

## MOTOR REPLACEMENT

### REMOVAL

1. Remove air compressor from vehicle.
2. Remove four screws from piston dome. Remove piston dome and its gasket. Remove valve plate and its gasket.

3. Remove piston sleeve.
4. Remove air filter.
5. Rotate eccentric until it is at the bottom of its stroke.
6. Referring to Figure 27, loosen Allen Head set screw which is at top of eccentric.
7. Remove eccentric from motor output shaft, and remove piston assembly through air filter opening as shown in Figure 28.
8. Remove two nuts holding on fan blade guard and remove the guard.
9. Loosen Allen Head set screw in fan hub, and remove fan blades.

## INSTALLATION

1. Install fan blades and tighten Allen Head set screw.
2. Install fan blade guard.
3. Place piston assembly in position with eccentric on motor output shaft. The eccentric must be positioned to contact the bearing on the motor.

4. Tighten Allen Head set screw, on eccentric to at least 5 ft. lbs. torque.
5. Install piston sleeve.
6. Install valve plate and its gasket, and install piston dome and its gasket.
7. Install four screws in piston dome.
8. Install air filter.
9. Install compressor in vehicle.

## FAN REPLACEMENT

### REMOVAL

1. Remove two nuts from fan guard and remove guard.
2. Loosen Allen Head set screw at center of fan hub. Remove fan from motor shaft.

### INSTALLATION

1. Install fan on motor shaft, tighten Allen Head set screw.
2. Install fan guard and install two nuts.

## HEIGHT CONTROL VALVE OVERHAUL

**IMPORTANT:** Height control valve-overhaul will be limited as shown in Figure 29. If repair procedures require replacement of valve body be sure to install new "O" rings and screens, as shown in Figure 29.

## HEIGHT CONTROL VALVE ADJUSTMENTS

### GENERAL

To properly adjust the height control valve, it is **ESSENTIAL** that the following procedures be followed and in the sequence mentioned:

Three main adjustments are required:

1. Overtravel lever center position adjustment.

2. Air intake and exhaust valve lever gap adjustments.
3. Time delay check.

**NOTE:** The height control valve assembly must be removed from vehicle to make the above adjustments.

Instructions for checking the ride height dimensions are explained under "Ride Height Check and Adjustment."

**IMPORTANT:** The silicone fluid should be drained from control valve assembly before making the first two adjustments.

### OVERTRAVEL LEVER CENTER POSITION ADJUSTMENT

1. Clean exterior of control valve assembly.

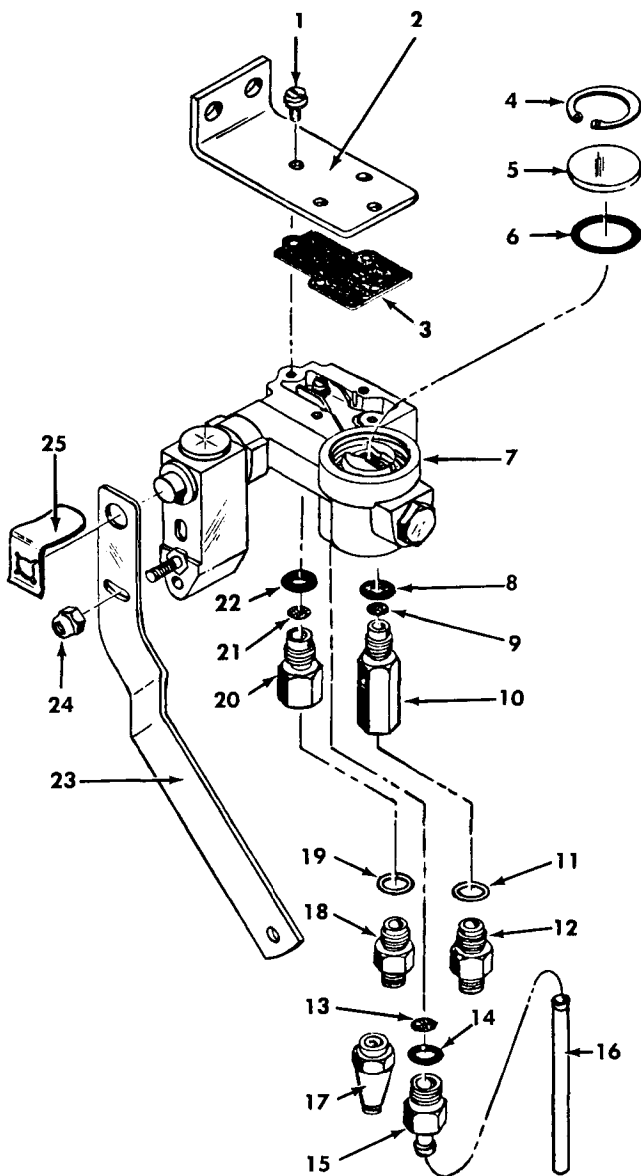

- 1 Screw, Cover Plate & Mounting Bracket
- 2 Cover Plate and Mounting Bracket
- 3 Gasket, Cover Plate & Mounting Bracket
- 4 Retaining Ring
- 5 Retainer, Delay Piston
- 6 "O" Ring
- 7 Valve Body
- 8 "O" Ring
- 9 Screen
- 10 Intake Valve Adapter Assembly
- 11 Gasket
- 12 Adapter
- 13 Screen
- 14 "O" Ring
- 15 Check Valve - Exhaust
- 16 Exhaust Tube
- 17 Tube Fitting
- 18 Adapter
- 19 Gasket
- 20 Adapter Assembly
- 21 Screen
- 22 "O" Ring
- 23 Arm
- 24 Nut, Arm Retaining
- 25 Fastener, Plug Retaining

A-1302

Figure 29-Height Control Valve

2. Remove cover and rubber O-ring from valve assembly, then drain off the Silicone fluid.

3. Remove exhaust fitting (15, figure 29) and exhaust screen (13, figure 29) from control valve.

4. Referring to Figure 31, scribe a line 1-3/8 inch from plug end of overtravel lever control body.

5. Place control valve assembly in vise as shown in Figure 33.

6. If vacuum source is available, attach supply hose to valve exhaust port (figure 30) using Sun

Tester fitting #115-3 or equivalent. Do not apply vacuum at this time.

7. Attach air pressure supply hose to air inlet port (figure 30). Do not apply pressure at this time.

8. Locate dial indicator in position as shown in Figure 31. Move overtravel lever to full air exhaust position - TOP OF DELAY PISTON FLUSH WITH TOP OF BORE - without overtraveling (position "C," figure 32). Relocate indicator push rod to just contact 1-3/8-inch mark on control body and reset indicator dial to zero (0) at this point (position "C", figure 32).



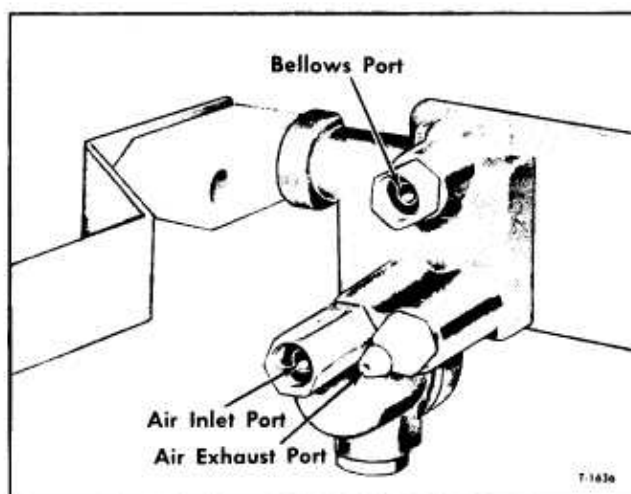

Figure 30—Height Control Valve Port Identification

9. Move overtravel lever to full air intake position without overtraveling (position "A", figure 32) (delay piston at bottom of bore). Take indicator reading which may vary from 0.160" to 0.190".

10. Repeat Steps 8 and 9 above to recheck this reading.

11. Divide the total travel dimension by two (example:  $0.170" \div 2 = 0.085"$ ), then move overtravel lever back this amount (0.085") to the center (position "B," figure 32).

**IMPORTANT:** Without disturbing lever center position, reset indicator dial to zero (0), which actually is 0.100" on indicator of type registering

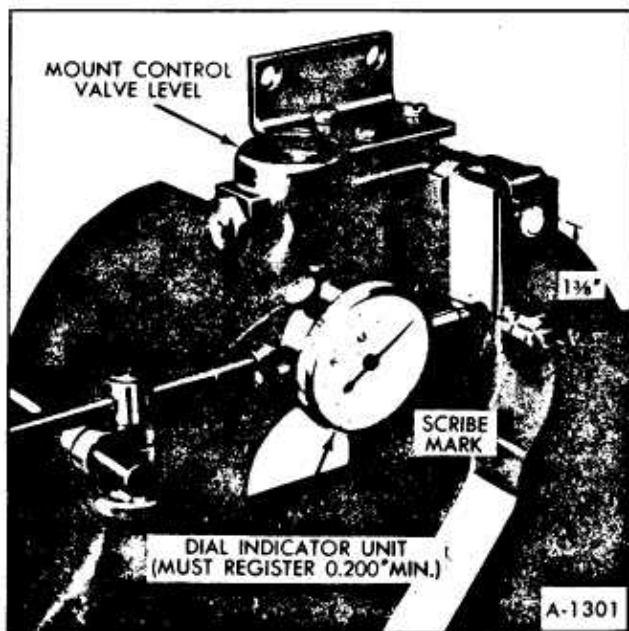

Figure 31—Dial Indicator Properly Installed

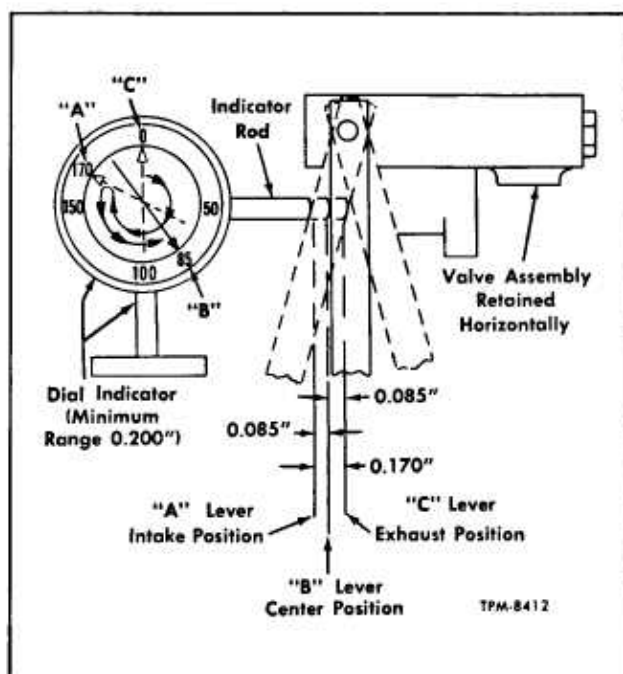

Figure 32—Locating Valve Overtravel Lever Center Position

0.100" for each revolution of indicator needle, then proceed with valve lever gap adjustments following:

## AIR INTAKE AND EXHAUST VALVE LEVER ADJUSTMENTS

**IMPORTANT:** Before making these adjustments the overtravel lever must be centered as explained previously.

Two methods of adjustment are available:

### 1. Using Both Air Pressure and Vacuum.

**NOTE:** If vacuum source is available, this method will take less time to perform adjustment. Vacuum source is used to make the exhaust valve lever gap check only.

### 2. Using Air Pressure Only.

**NOTE:** When this method is used, it will take longer to perform adjustments as the valve cover must be in place each time air pressure is applied and then removed to permit adjustment of exhaust valve lever.

## Method Using Air Pressure and Vacuum

1. If air supply and vacuum lines were not connected to control valve assembly as directed previously when centering valve overtravel lever, connect lines.

2. Apply air pressure and regulate it to 80 to 110 psi. Apply vacuum and regulate it at approximately 15 inches.

3. Move overtravel lever fore and aft several times and then back to true center position.

4. Starting at true center position, slowly move lever to where air intake valve just begins to open. Listen for escaping air. Note reading on dial at this point. Reading should be 0.025" to 0.027" from lever center position. Bend lever to correct setting. Refer to Figure 33.

5. Return overtravel lever to center position. Slowly move lever to exhaust side and at same time note the vacuum gauge reading. When vacuum just begins to fall off, the exhaust valve has opened. Valve should open when overtravel lever is moved 0.035" to 0.037" from center position. On both front and rear control valves, bend lever to correct setting. Refer to Figure 33.

6. Recheck intake and exhaust valve lever gaps, then proceed with "TIME DELAY CHECK" explained later.

## Method Using Air Pressure Only

**NOTE:** This method may be performed when a vacuum source is not available.

1. Connect air supply hose (80 to 110 psi) to air inlet port (figure 30).

2. To adjust air intake valve lever gap:

a. Move the overtravel lever slowly from true center position to point where intake valve just begins to open. Listen for escaping air. Note reading to dial at this point which should register 0.025" to 0.027".

b. Bend lever to correct setting. Refer to Figure 33.

3. To adjust air exhaust valve lever gap:

a. Install valve cover on the valve using the rubber gasket and four attaching screws.

b. Being careful not to disturb indicator setting, disconnect air supply from the air inlet port and connect it to the bellows port (figure 30).

c. Move overtravel lever slowly to open exhaust port while observing the indicator dial. Air should start to escape from exhaust port when indicator registers 0.035" to 0.037". If adjustment is necessary, shut off air pressure supply and remove valve cover. Bend lever to correct setting, then install cover and recheck valve opening dimension.

d. Recheck valve lever gaps, then proceed with "TIME DELAY CHECK" following:

## TIME DELAY CHECK

### Preliminary Procedures

After the valve lever gaps have been properly adjusted, the time delay check must be performed. A four to eighteen seconds delay from the closing of one valve to the opening of the other is recommended. Also, valves should close from full-open position within four seconds.

1. Pour 5.5 cc  $\pm$  0.25 cc of Silicone fluid (3,000 Centistokes viscosity at 25°C.) into delay piston bore. With valve body tilted slightly, as shown in Figure 34, carefully operate overtravel lever fore and aft to vent air from fluid. When all air has been expelled from piston pin cavity, check fluid level (figure 35).

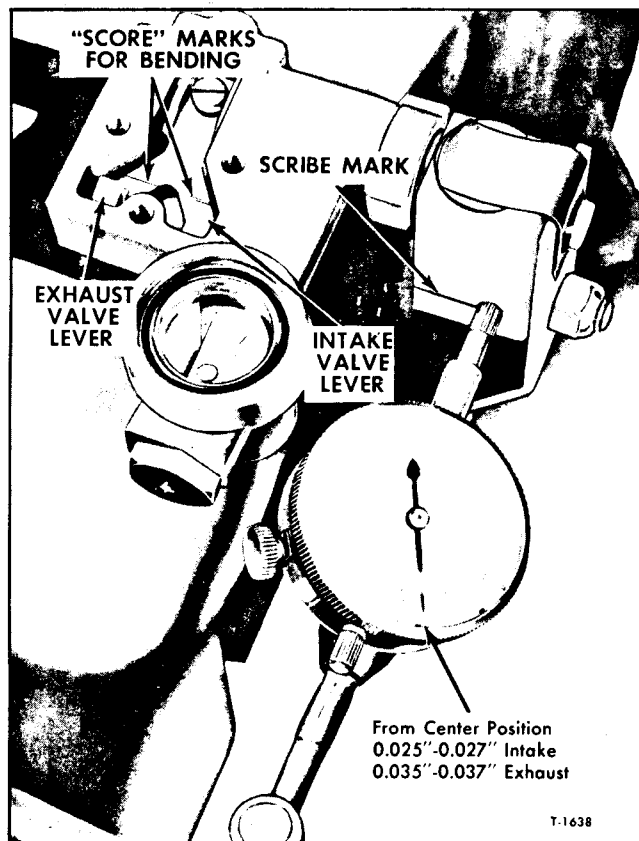

Figure 33—Method of Adjusting Air Valve Lever Gaps

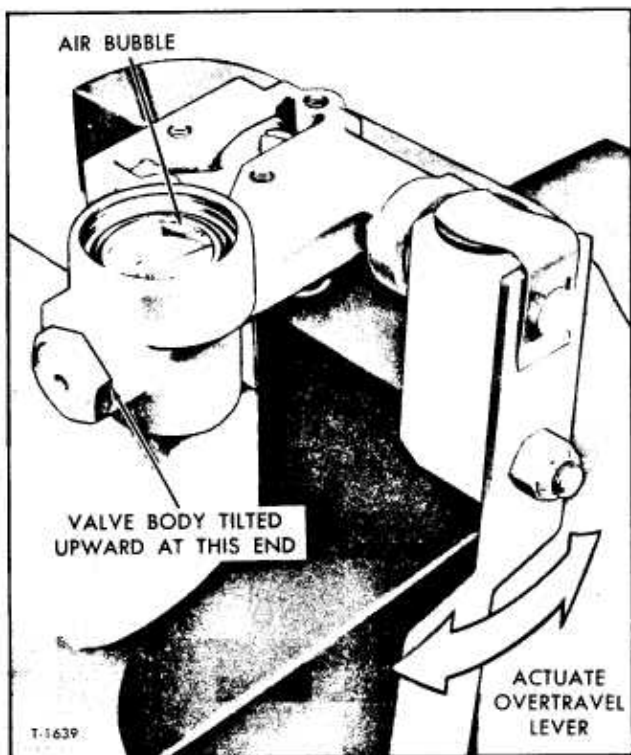

Figure 34-Venting Air From Silicone Fluid

**IMPORTANT:** With valve assembly level, take measurement from center of bore only. Add or remove fluid to bring fluid to dimension shown in Figure 35. An eyedropper will serve for this purpose.

2. Place new delay piston cover O-ring in groove of valve body. Install cover with retainer.

3. Place valve assembly vertically in holding vise (figure 36).

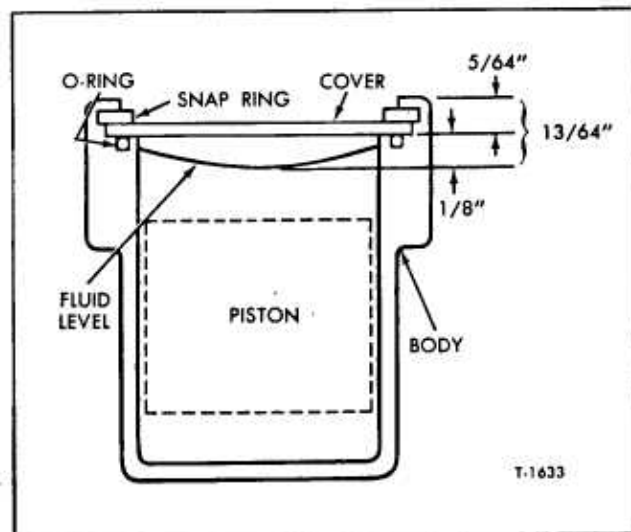

Figure 35-Silicone Fluid Level

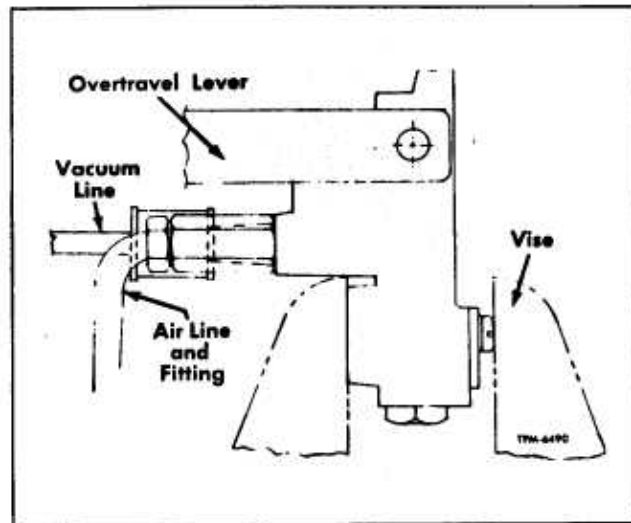

Figure 36-Valve Positioned for Time Delay Check

4. Cycle arm up and down for approximately one minute.

### Air Inlet Time Delay Check

1. Connect air pressure supply hose to valve air inlet port (figure 30).

2. Move overtravel lever upward (quickly) approximately two inches and simultaneously start counting the number of seconds before air starts to escape from bellows port. A delay of four to eighteen seconds should exist. Repeat this check.

### Air Exhaust Time Delay Check

To time the delay for exhaust, two methods can be used; one using vacuum source and one using air pressure.

#### 1. Method Using Vacuum

a. Connect vacuum hose to air exhaust port (figure 30). Adjust vacuum to 15 inches.

b. Move the overtravel lever downward (quickly) approximately two inches and simultaneously start counting the number of seconds before the vacuum gauge starts to drop off. A delay of ten to fifty seconds should exist. Repeat this check.

#### 2. Method Using Air Pressure

a. Install valve cover with rubber gasket on valve assembly.

b. Connect air pressure supply hose to bellows port (figure 30).

c. Move overtravel lever downward (quickly) approximately two inches and simultaneously start counting the seconds before air starts to escape from the exhaust port. A delay of ten to fifty seconds should exist.

**IMPORTANT:** A time delay over fifty seconds could mean too large a valve lever gap adjustment and a time delay under ten seconds would mean too small a valve lever gap adjustment. If the time delay is not within 10 to 50 seconds, first recheck the fluid level. If fluid level is satis-

factory, the valve lever gap adjustment must be repeated, step by step.

**NOTE:** (Refer to figure 29.) After obtaining proper valve adjustments, install valve cover using new rubber gasket (3). Install new screen (21), in bellows port, then using new O-ring (22), install outlet adapter (20) into bellows port. If screen (13) was removed from exhaust port, install new screen and exhaust fitting (15).

**NOTE:** Place tape over ends of air line ports until such time valve assembly is installed on the vehicle.

## COMPONENT INSTALLATION

### AIR COMPRESSOR AND PRESSURE SWITCH INSTALLATION

1. Referring to Figure 2, install pressure switch by attaching to fitting at mounting bracket.
2. Install compressor to mounting bracket using four nuts and bolts.
3. Connect motor lead to pressure switch. Connect ground wire to mounting bracket.
4. Place compressor switch assembly in position and fasten with three bolts to vertical bracket.
5. Install two bolts on horizontal bracket.
6. Connect pressure-switch assembly wiring.
7. Connect air line to compressor-switch assembly.
8. Run compressor to pressurize system.

### AIR RESERVOIR INSTALLATION

1. Referring to Figure 5, install drain cock, safety valve, and schrader valve.
2. Install reservoir.
3. Install retaining bolt and nut and tighten securely.
4. Connect two air lines to tank.

5. Run compressor to pressurize system and check for leaks.

### HEIGHT CONTROL VALVE INSTALLATION

Before installing height control valve assembly, see that air line fittings are clean and undamaged.

**NOTE: DO NOT USE SEALING COMPOUND ON THREADS.** Sealer is unnecessary, and if used, may cause valves to stick. Absolute cleanliness is essential when installing height control valves. Dirt and sealing compound must be kept out of valves. Even minute particles of foreign matter may become lodged in valve cores or flapper valves and may seriously affect operation of suspension system.

1. Position height control valve at mounting studs on wheelwell. Attach with two nuts and tighten to 80-120 in.-lbs. torque.
2. Connect air supply line to intake adapter, connect bellows air line to outlet adapter. Tighten air line connector nuts firmly.

3. Connect height control valve overtravel lever to valve link and tighten to 60-90 ft.-lbs. Build up air pressure in system and test for leaks. Check ride height dimension and adjust if necessary as described later in this section.

### AIR BELLOWS INSTALLATION

1. Place air bellows piston on floor, cone section pointing up. Place air bellows in piston, with open end pointing up.

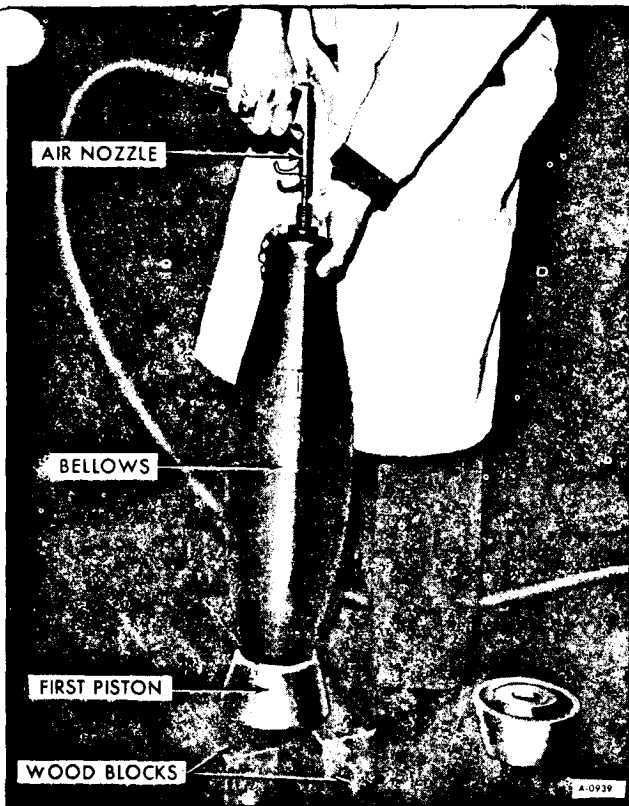

Figure 37—Applying Shop Air to Air Bellows



Figure 38—Installing Second Piston on Air Bellows

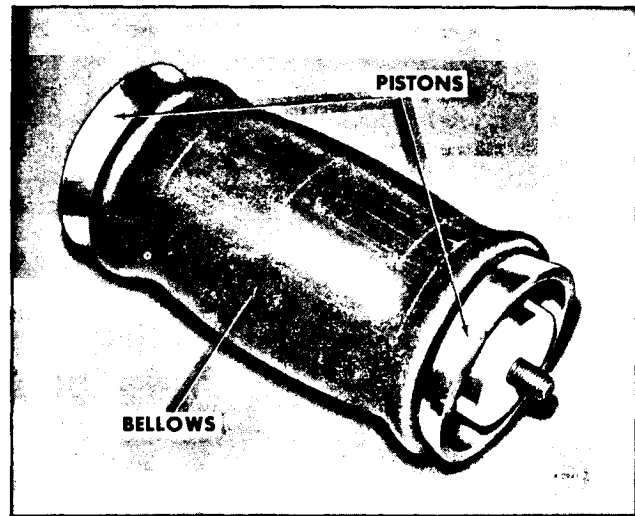

Figure 39—Air Bellows Assembly

2. Referring to Figure 37, apply shop air to bellows while pushing down on bellows, release air pressure. The bellows will fold over the piston.

3. Place second piston over top of bellows and apply shop air again as shown in Figure 38. Push down on bellows and release air pressure. Bellows will fold over piston. Completed bellows assembly should appear as shown in Figure 39.

4. Raise rear wheels to bring top of control arms close together. Block control arm as shown in Figure 20. Place air bellows in position. Install star washers and lock nuts. Torque lock nuts to 50-60 ft.-lbs.

5. Connect air line and move height control valve arm up to apply air to bag.

6. Connect leveling valve link. Lower vehicle to ground and allow leveling valve to bring it to proper ride height.

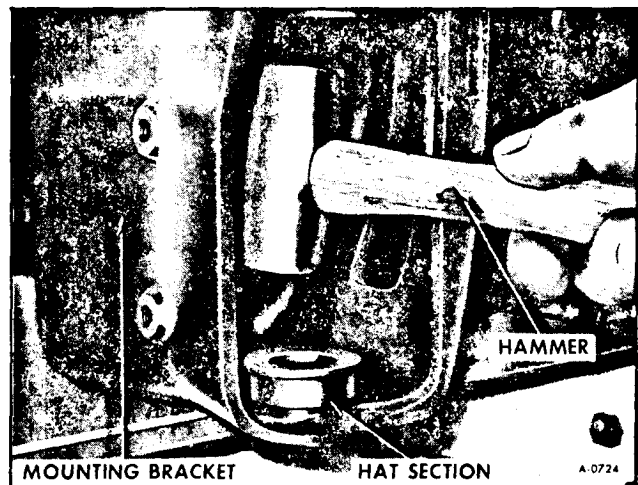

Figure 40—Repositioning Hat Section

## CONTROL ARM INSTALLATION

1. With the aid of hammer as shown in Figure 40, tap back hat section spacers (2) in mounting bracket to provide more room for control arms in bracket.
2. Place control arm in position in mounting bracket. Position thrust pack journal bearing between control arm and mounting bracket. (See figure 41).
3. Press bracket pins into proper position.
4. Place nut lock in position and install control arm lock nuts.
5. Tighten control arm lock nuts until hat section spacers are firmly seated, then back off nut until control arm moves freely, and retorque nuts to 15-20 lbs.-ft. Bend ears on nut lock over nut. (See figure 18).
6. Press in spindles.
7. Referring to Figure 17, position unit on vehicle and install four bolts from mounting bracket to frame rail. Install two (2) bolts from mounting bracket to frame crossmember (see figure 16).
8. Referring to Figure 16, install brake backing plate by installing four bolts and nuts retaining plate to control arm.
9. Referring to Figure 14, install brake drums and hubs on spindle. Tighten castilated nut (figure 13) to 25-30 ft.-lbs., back nut off one half turn and then finger tighten until cotter pin can be installed.

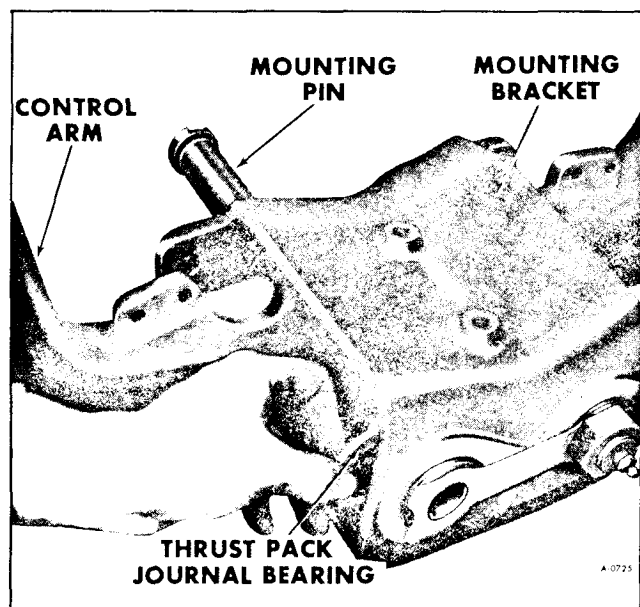

Figure 41—Installing Thrust Bearings

10. Install shock absorbers to control arms.
11. Install brake lines. Connect all mounting brackets and connect lines at brake backing plates and at control arm mounting bracket.
12. Referring to Figure 9, install air bellows.
13. Referring to Figure 7, connect leveling valve link and torque nut to 60-90 lbs.-ft.
14. Apply air to bellows.
15. Install tire and wheels.
16. Lower vehicle to floor and allow leveling valve to bring vehicle to ride height.
17. Bleed brakes as described in Section 5 Brakes.

## SHOCK ABSORBER INSTALLATION

Block control arms in an up position with a wooden block about one inch in thickness as shown in Figure 20. Install top of shock in upper control arm and secure with nut. Install bottom of shock on mounting bracket on frame rail, and secure with nut.

## POWER LEVEL VALVE INSTALLATION

1. Wrap threads on air line fittings with teflon tape.
2. Install lines to back of valves, referring to figure 44. On the right valve, red line goes to the port marked "MAN.," blue line goes to the port marked "OUT," and yellow lines goes to the port marked "AUTO." On left valve, red line goes to the port marked "MAN.," gray line goes to the port marked "OUT," purple line goes to the port marked "AUTO."
3. Install two (2) screws holding valve to mounting panel (see figure 22).
4. Install four (4) screw holding mounting panel to dash.
5. Install control knob using Allen Head screw in center of knob.
6. Close drain cock on air reservoir, place control

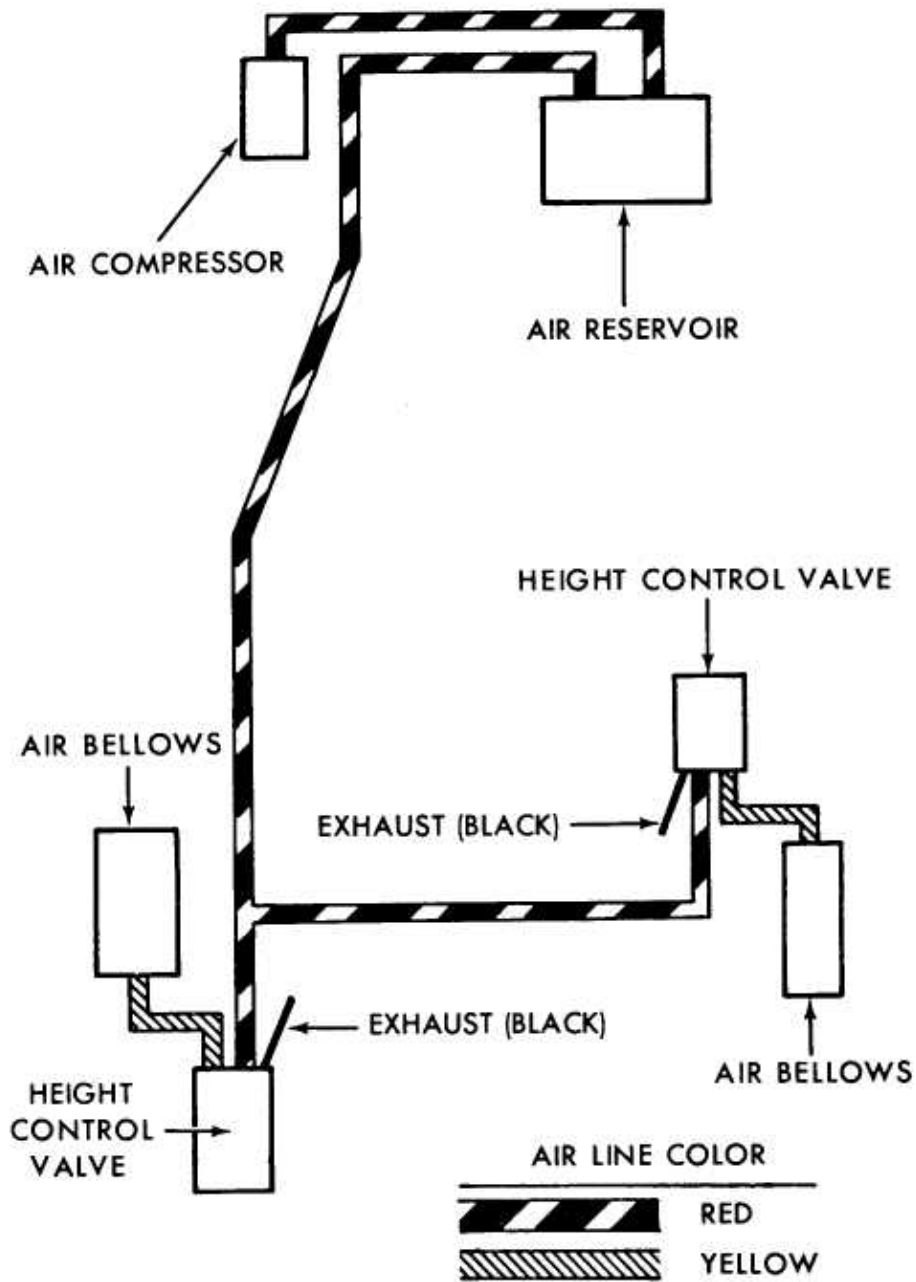

A-0942

@2-9.00 Neg. A-0942

Figure 42-Standard Rear Suspension Schematic

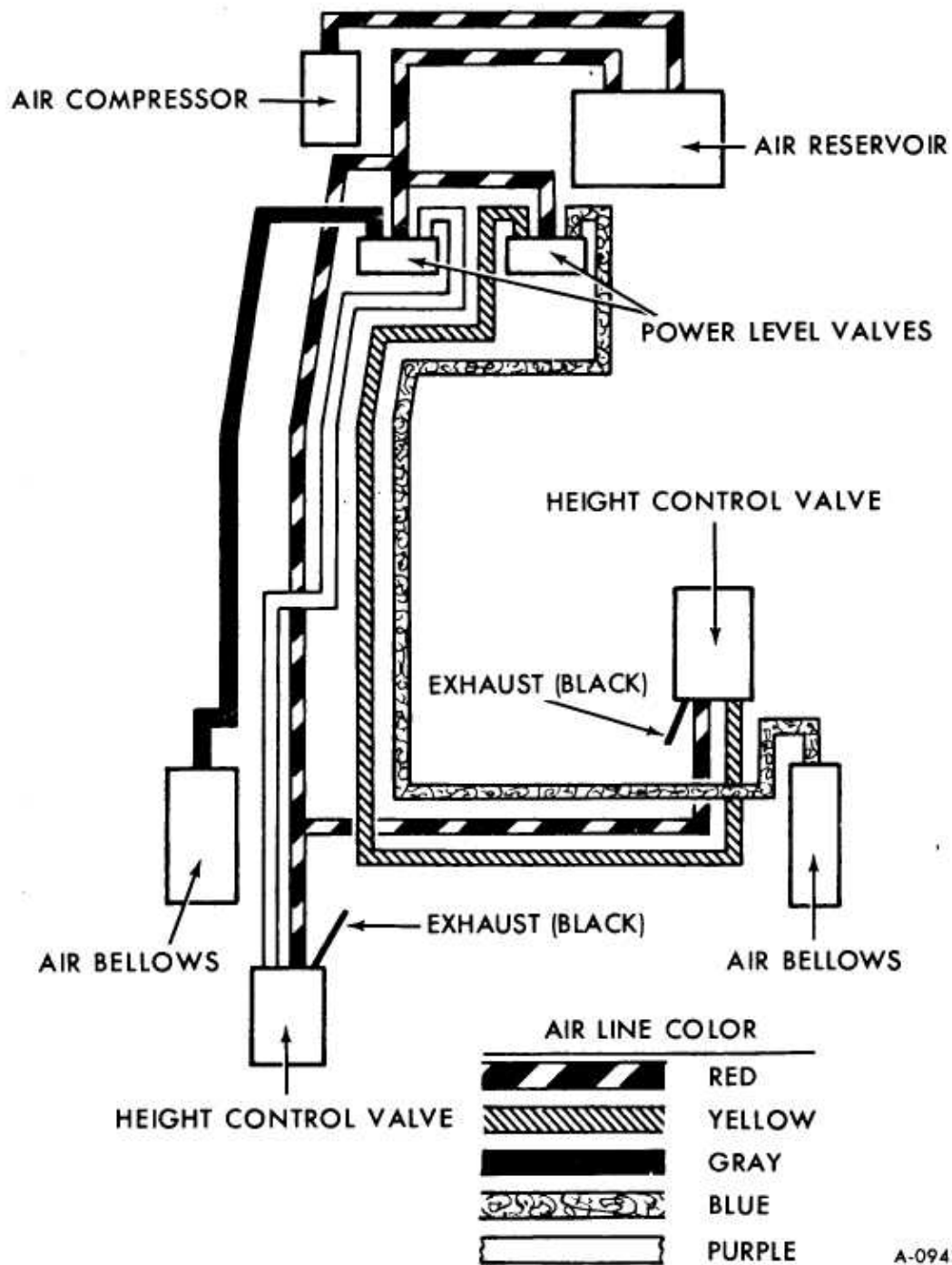

A-0943

©2-9.00 Neg. A-0943

Figure 43-Rear Suspension Schematic (With Power Level)



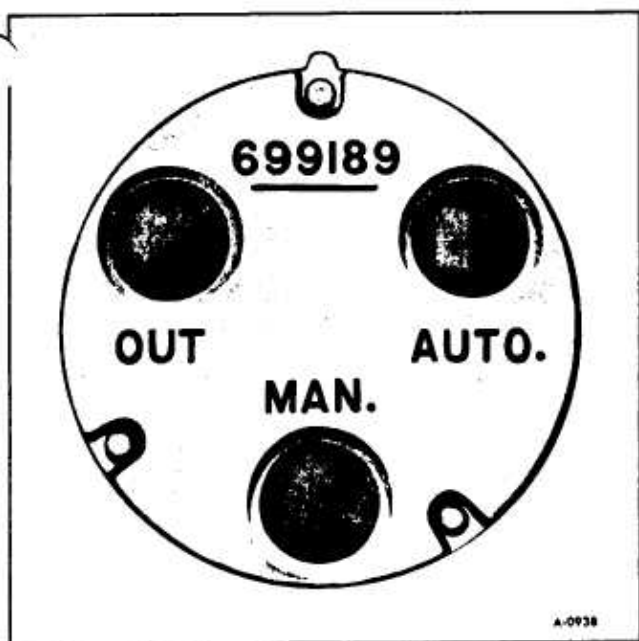

Figure 44—Power Level Valve Port Identification

knob in travel position, and operate compressor until suspension comes up to ride height. Checks for air leaks.

## AIR LINE INSTALLATION

Nylon tubing is used throughout the motor home for rear suspension air lines as shown in schematics,

Figures 42 and 43. It is flexible, durable and weather-resistant.

When installing nylon tubing make sure it is not routed close to a heat source, such as exhaust manifold or muffler. Tubing must be cut to required length and related fittings assembled.

**IMPORTANT:** Whenever threaded fittings on the rear suspension (excluding the height control valve, itself) are disassembled for any reason—be sure threads on male portion of fitting are wrapped with teflon tape or equivalent to avoid leakage.

1. Cut nylon tube to required length and be sure components are free of nicks or scratches.
2. Position nut and sleeve over tube.
3. Push tube insert into tube, then push tube and insert into fitting until firmly seated.
4. Seat sleeve into fitting, then tighten nut securely.

5. Install fitting at other end of nylon tube using the above procedure, then check for leaks.

6. If any trouble symptoms, such as slow suspension operation, indicates a restricted or clogged air lines, disconnect suspected tube or hose at both ends and blow through it to make sure the passage is clear. Inspect tubing and hose for partial restrictions such as dents or kinks. If such condition is found, replace the tubing.

## ON-VEHICLE ADJUSTMENTS

### REAR WHEEL ALIGNMENT

Proper rear wheel alignment must be maintained to ensure correct handling and satisfactory tire life.

Before checking alignment the following inspections should be made.

1. Check that tires are inflated to 60 psi.
2. Check wheel bearing adjustment and correct if necessary.

**NOTE:** Rear wheel alignment requires the vehicle to be level while being checked. Full weight must be on wheels with vehicle empty.

### TOE-IN MEASUREMENT

Toe-in may be measured from center of tire tread or from inside tires or rims. Measurements at both wheels must be made in same relationship (See "G" and "F," figure 45).

If measurement is to be made from center of tire treads, first hoist vehicle and spin wheels to obtain a center line on tire tread. Roll vehicle ahead several feet to where the inspection is to be made. This will remove any slack caused by looseness in wheel bearings.

Measure at point "F" and "G". The toe-in should follow the relationship.

$$G = F \pm .06"$$

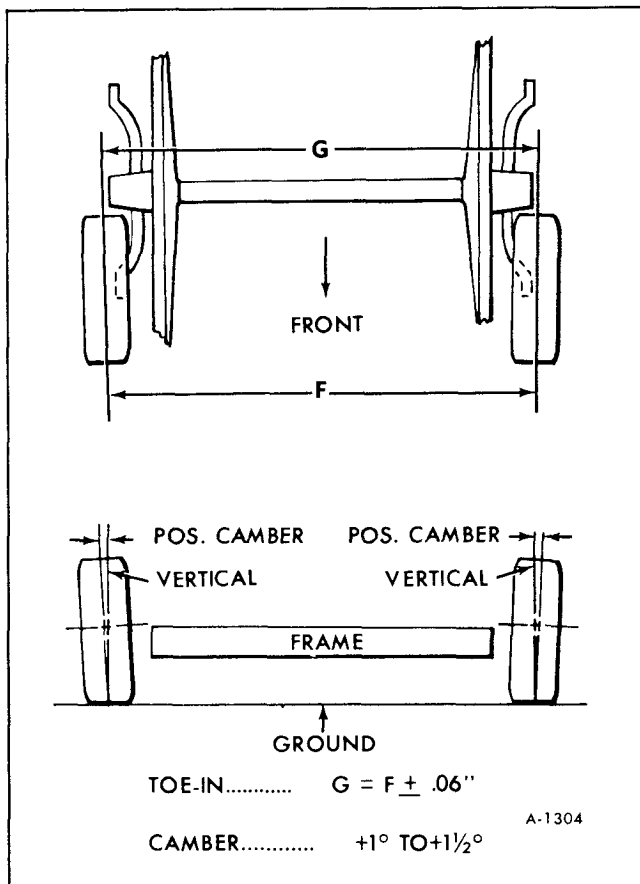

Figure 45-Rear Wheel Alignment Chart

### TOE-IN ADJUSTMENT

If toe-in is not correct it must be shimmed as shown in Figure 46. Follow this procedure for adjustment.

1. Raise vehicle off floor.

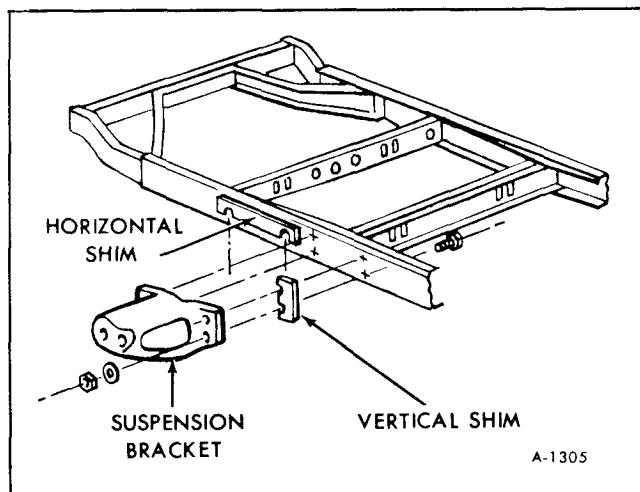

Figure 46-Rear Wheel Shim Location

2. Loosen six bolts on mounting bracket.
3. Insert proper shim as shown in Figure 46.
4. Tighten 4 retaining nuts on frame rail to 65-85 lbs.-ft. torque. Tighten 2 retaining nuts on cross-member to 50-60 lbs.-ft. torque.
5. Lower vehicle to floor and recheck alignment.

### REAR WHEEL CAMBER

The rear wheels are set with positive camber. Positive camber is outward inclination of wheels at top.

In checking camber, it is recommended that an accurate gauge be used. The camber should be set at  $+1^\circ$  to  $+1\frac{1}{2}^\circ$  (See figure 45).

Excessive positive camber results in irregular wear of tires at outer shoulder. Negative or reverse camber causes wear at inner shoulders.

Camber is adjusted by shimming as shown in Figure 46. Following the same shimming procedure as that used before to set toe-in.

### AIR COMPRESSOR PRESSURE SWITCH ADJUSTMENT

The switch is designed to maintain air pressure in the air reservoir between 100 and 120 psi. If the

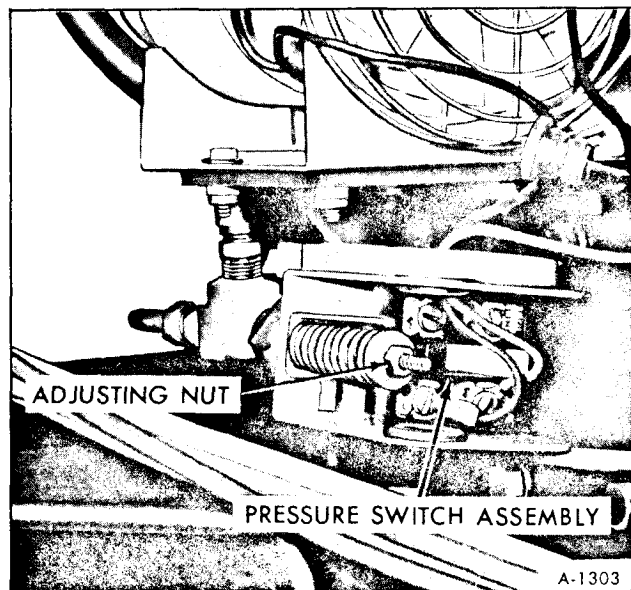

Figure 47-Air Compressor Pressure Switch Adjustment

pressure in the reservoir drops to 100 psi the contact points will close and this will complete the circuit supplying electricity to the compressor. If the pressure raises above 120 psi the contact point will open and open the circuit to the compressor. This setting may be adjusted at the nut which is located on the end of the spring inside the cover, refer to Figure 47. The pressure will rise by tightening the spring. Both the cut-in pressure and the cut-out pressure will be affected by this adjustment. The pressure can be measured at the schrader valve on the reservoir.

## RIDE HEIGHT ADJUSTMENT

The ride height at the rear suspension may be checked at an elongated slot on the frame rail, refer to Figure 48.

To adjust ride height loosen adjustment nut on height control valve (see figure 49). The valve arm has an elongated hole at the adjustment nut. This allows the valve arm to move in relation to the valve itself, and thus allows the ride height to change. Intake and exhaust valves of height control valve can then be operated independently of linkage. When proper ride height is reached tighten nut to 70-80 lbs.-in.

Height control valve lever will move 3/16 inch up or down from neutral position (free travel) without causing any valve action. If amount of adjustment required falls within these limits, adjust lever the required amount. However, frame will not raise

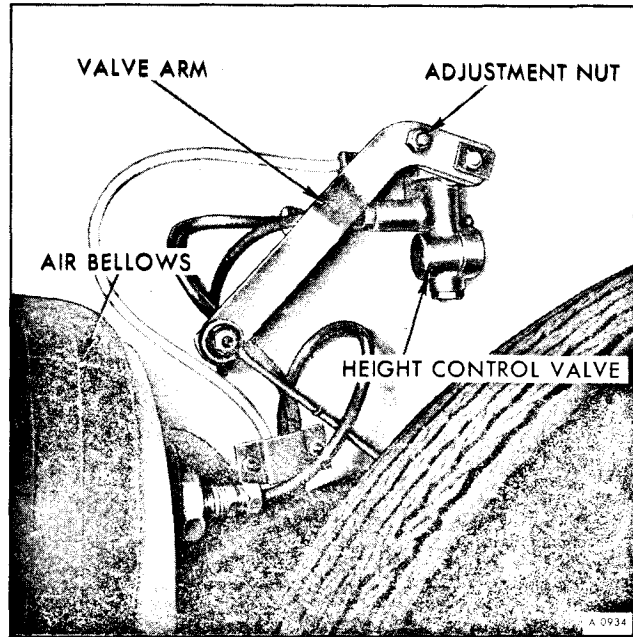

Figure 49—Location for Rear Ride Height Adjustment or lower until load is increased or decreased to actuate height control valve.

If any one of the height control valves does not function properly with the lever correctly adjusted, check for restricted air lines. If valve still does not hold frame at normal ride height with lever properly adjusted, and with no restriction in air line, valve should be overhauled or replaced with a new or rebuilt unit.

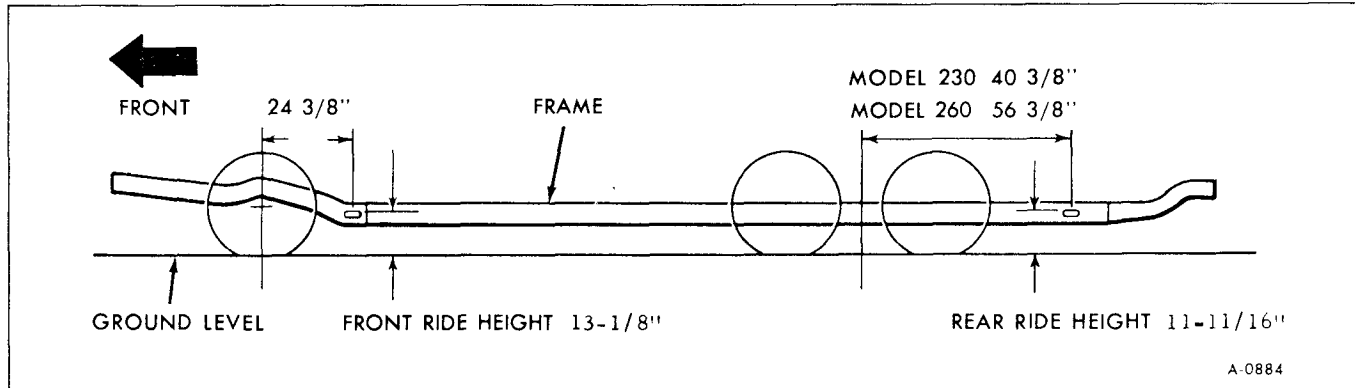

Figure 48—Checking Motor Home Ride Height

## PERIODIC MAINTENANCE

### AIR COMPRESSOR FILTER REPLACEMENT

The air filter on the compressor should be cleaned or replaced every six months or 6,000 miles.

The filter is removed by removing the filter retainer at the front of the compressor. The filter screen and filter element can now be removed. The filter element can be washed in soap and water. It should be fully dried before replacing it in the compressor.

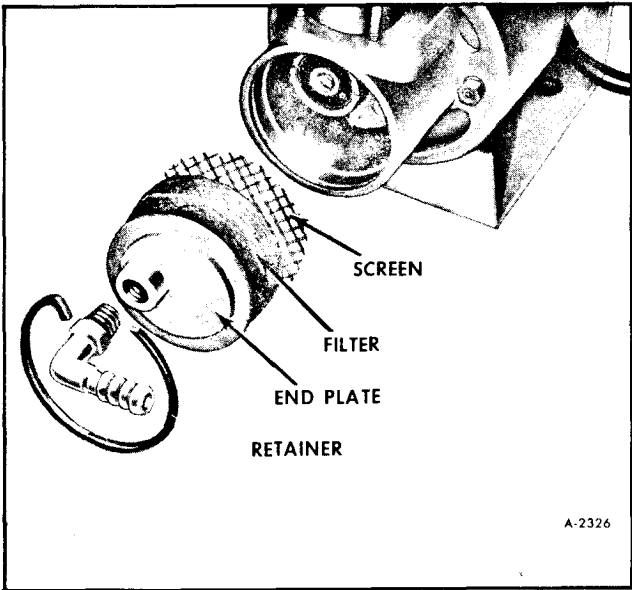

Figure 50-Compressor Air Filter Removed

### AIR RESERVOIR

Referring to Figure 5, condensation should be drained at least once a month. To drain reservoir properly, leave drain cock open until all air escapes and draining stops.

Air tank mounting bolts, and brackets should be checked at regular intervals for looseness and tighten if necessary. Air reservoir may be cleaned inside using steam or hot water. If corrosion or other damage has weakened tank it must be replaced.

### LUBRICATION

Details on lubrication of rear suspension components are covered in Section 0 at the beginning of this manual.

## REAR SUSPENSION TORQUE SPECIFICATIONS

LOCATION	TYPE OF PART	TORQUE
Center mounting bracket to frame rail nuts (4).....	Nut	65-85 ft.-lbs.
Center mounting bracket to crossmember nuts (2) .....	Nut	50-60 ft.-lbs.
Height control valve mounting Bolt .....	Bolt	80-120 in.-lbs.
Height control valve link Link to arm nut.....	Nut	60-90 ft.-lbs.
Link to control arm nut .....	Nut	60-90 ft.-lbs.
Control arm lock nut.....	Nut	15-20 ft.-lbs.



# SECTION 5

## BRAKES

Contents of this section are listed below:

SUBJECT	PAGE NO.
General Information .....	5-1
Brake System Trouble Diagnosis .....	5-4
On-Vehicle Servicing .....	5-14
Component Removal .....	5-17
Component Overhaul .....	5-25
Major Component Inspection .....	5-36
Component Installation .....	5-39
Specifications .....	5-45
Torque Specifications .....	5-45
Special Tools .....	5-45

## GENERAL INFORMATION

The Motor Home is equipped with disc brakes on the front wheels, and has drum brakes on the rear wheels. They are hydraulically powered by a split hydraulic system.

When the brake pedal is depressed, the piston in the master cylinder forces fluid under pressure to a wheel cylinder at each wheel, which in turn, pushes the brake shoes against the brake drum. As the shoes contact the drum, the friction between the shoes and the rotating drum moves the primary shoe downward against the adjusting screw which acts as a link to transmit the force of the primary shoe to the lower end of the secondary shoe. With the upper end of the secondary shoe being held by the stationary anchor pin, the secondary shoe is wedged against the drum. This wedging action, due to frictional force impacts the self-energizing action to the braking effort and thereby decreases the effort required by the driver to stop the car.

### SELF-ADJUSTING BRAKE

The Motor Home is equipped with self-adjusting brakes. The self-adjusting brake mechanism consists of an actuating link, adjuster lever, adjuster lever return spring, override spring and override pivot.

### OPERATION (DRUM TYPE)

The self-adjusting brake mechanism operates only when the brakes are applied while the vehicle is

moving rearward and only when the secondary shoe moves a predetermined distance toward the brake drum.

As the vehicle moves rearward and the brakes are applied, friction between the primary shoe and the drum forces the primary shoe against the anchor pin. Hydraulic pressure in the wheel cylinder forces the upper end of the secondary shoe away from the anchor pin. As the secondary shoe moves away from the anchor pin, the upper end of the adjuster lever is prevented from moving by the actuating link. This causes the adjuster lever to pivot on the secondary shoe forcing the adjuster lever against the adjusting screw sprocket. If the brake linings are worn enough to allow the secondary shoe to move the predetermined distance, the adjuster lever will turn the adjusting screw sprocket one or two teeth, depending on lining wear. If the secondary shoe does not move the predetermined distance, movement of the adjuster lever will not be great enough to rotate the adjusting screw sprocket.

When the brakes are released, the adjusting lever return spring will move the adjuster lever into the adjusting position on the sprocket.

An override feature is build into the self-adjusting brake which allows the secondary shoe to be applied in reverse in the event the adjusting screw becomes "frozen" preventing the self-adjuster from operating.

When the vehicle is moving forward and the brakes are applied, the upper end of the secondary

shoe is forced against the anchor pin due to the self-energizing action of the brakes and the self-adjuster does not operate.

## **OPERATION (DISC TYPE)**

The significant feature of the single piston caliper operation is that it is free to slide on the two mounting bolts which thread into the support bracket.

At application of the brakes, the hydraulic pressure behind the piston increases. Pressure is exerted equally against the bottom of the piston and also against the bottom of the piston bore. The pressure applied to the piston is transmitted to the inboard shoe and lining, forcing the lining against the inboard disc surface. The pressure applied to the bottom of the piston bore forces the caliper to slide or move inboard on the mounting bolts. Since the caliper is one piece, this movement toward the vehicle causes the outboard section of the caliper to apply pressure against the back of the outboard shoe and lining assembly, forcing the lining against the outboard disc surface. As hydraulic pressure builds up, the shoe and lining assemblies are pressed against the disc surfaces with increased force, bring the vehicle to a stop.

In actual practice, the application and release of the brake pressure causes a very slight movement of the piston and caliper. Upon release of the braking effort, the piston and caliper merely relax into a released position. In the released position, the shoes do not retract any appreciable distance from the disc surfaces.

As the brake lining wears, the piston moves out of the caliper bore and the caliper repositions itself on the mounting bolts and equal distance inboard. In this manner the caliper assembly maintains the inboard and outboard shoe and lining in the same relationship with the disc surface throughout the full life of the lining.

## **MASTER CYLINDER**

### **DESCRIPTION**

The dual master cylinder is designed so that the front and rear brakes have separate hydraulic systems. The hydraulic pressure developed in both systems is equal at all times since the front piston is balanced between the hydraulic pressure in each system.

Malfunction in either system has no effect on the other system but is immediately evident to the driver because of the additional pedal travel required to actuate the remaining half of the dual brake system. Also, a pressure differential sensing switch in the system actuates a warning light on the instrument panel.

## **OPERATION**

Two brake fluid reservoirs are cast integrally with the master cylinder and supply fluid to the areas ahead of the primary seals through the compensating ports and between the primary and secondary piston seals through by-pass ports in the casting.

Within the bore of the master cylinder is the rear piston assembly, which is composed of the piston, return spring, retainer, spacer and screw. Also in the bore is the front piston with a primary and two secondary piston seals are a front piston return spring and retainer.

Fluid is directed to the wheels through two hydraulic outlets, one for the front brakes and one for the rear brakes.

In the event the engine stalls, the vacuum chambers within the power cylinder provides adequate vacuum reserve for two or three brake applications. If the vacuum check valve is defective or braking has depleted the vacuum reserve, the driver can still operate the brakes in a conventional manner but more effort is required due to the loss of power assist.

## **WHEEL CYLINDER**

### **OPERATION**

Each wheel cylinder contains two pistons and two rubber cups which are held in contact with the pistons by a central coil spring with cup expanders to provide a fluid-tight seal. The wheel cylinder cups are of a special heat resisting rubber. Cups of this material must have an expander to hold the lips of the cup out against the wheel cylinder bore. These cup expanders are crimped on each end of the wheel cylinder spring. The inlet port for brake fluid is located between the pistons so that when fluid pressure is applied, both pistons move outward toward the ends of wheel cylinders. The pistons impart movement to the brake shoes by means of connecting links which seat in the pistons and bear against webs of the shoes. Rubber boots enclose both ends of the cylinder to exclude foreign matter. A valve for bleed-

ing the brake pipes and wheel cylinder is located above the inlet port.

## COMBINATION VALVE

A combination is incorporated into the brake system. It performs three functions; a balance function, a metering function, and a warning switch.

### METERING VALVE FUNCTION

The metering section of the combination valve operates to "hold off" hydraulic flow (pressure) until about 130 psi has been built up in the system before applying the front brakes. The pressure then blends to full line pressure at approx. 400-600 psi line pressure. There is no flow restriction when the brakes are released.

### BALANCE FUNCTION OR WARNING SWITCH

The fluid from front and rear systems is separated by a hydraulically balanced sealed piston. A spring loaded switch plunger rides in a groove in the switch piston. Any pressure differential sufficient to overcome the switch plunger spring and friction causes a shift of the piston in the direction of reduced pressure, causing the switch plunger to ride up out of its groove and the switch to make contact and light the warning light. (100-300 psi differential is required).

In addition, this piston is designed to hydraulically recenter itself once the pressure balance is restored (leak is fixed.)

## PARKING BRAKE

### OPERATION

The parking brake control system, which applies the four rear brakes, uses a hand operated lever,

cables and brake shoe levers and struts. The front cable runs from the hand lever along the underbody to the front equalizer. The intermediate cable then runs to outside of each frame rail, and back to an intermediate equalizer. From this point a cable runs to each of the four brake drums. Each of these cables connects to the free lower end of a brake shoe lever. These levers (one in each rear brake shoe assembly) pivot on the secondary shoes. Struts are mounted between the brake shoe lever and the primary shoes. When the parking brake lever is raised, all cables are put in tension and the rear brake shoes are expanded against the drums.

## POWER CYLINDER

The Power Brake Unit is a self-contained hydraulic and vacuum unit, utilizing manifold vacuum and atmospheric pressure for its power.

This unit permits the use of a low brake pedal as well as less pedal effort than is required with the conventional (nonpower) hydraulic brake system. The unit is mounted on the front side of the dash panel and directly connected to the brake pedal.

A power brake is used with the brake system to reduce the braking effort required by the driver. A combined vacuum and hydraulic unit, which utilizes engine manifold vacuum and atmospheric pressure, is used to provide power assisted application of vehicle brakes.

The unit is used in conjunction with a conventional brake system. From the master cylinder connection outward to the wheel units, there is no other change in the brake system.

In addition to the master cylinder connections, the unit requires a vacuum connection to the engine intake manifold (through a vacuum check valve) and a mechanical connection to the brake pedal. This unit is self-contained.

The vacuum power unit contains the power piston assembly, which houses the control valve and reaction mechanism, and the power piston return spring. The control valve is composed of the air valve (valve plunger), the floating control valve assembly, and the push rod. The reaction mechanism consists of a hydraulic piston reaction plate and a series of

levers. An air filter, air silencer, and filter retainer are assembled around the valve operating rod filling the cavity inside the hub of the power piston. The push rod or valve operating rod, which operates the

air valve, projects out of the end of the power unit housing through a rubber dust guard. A vacuum check valve assembly is mounted in the front housing assembly for connection to the vacuum source.

## BRAKE SYSTEM TROUBLE DIAGNOSIS

### TESTING FOR LEAK IN HYDRAULIC SYSTEM

**NOTE:** If there is any evidence of air in system, brakes must be bled before making this test.

1. Apply brakes manually, holding as steady a force as possible.

2. If pedal sinks slowly toward floor, a leak is indicated. Check for location of the leak by examining all lines, connections and wheel cylinders. If external leak is not found, remove master cylinder, disassemble and inspect parts. Leaks will usually be past primary piston cup due to porous or damaged cup or cylinder bore.

### MASTER CYLINDER, WHEEL CYLINDER AND DRUM BRAKES

#### TROUBLE DIAGNOSIS CHART

#### SPRINGY, SPONDY PEDAL

Cause	Remedy
Air trapped in hydraulic system.  Brake adjustment not correct. Bent shoes Compensating port closed. Improper brake fluid.  Improper lining thickness or location. Drums worn too thin. Master cylinder filler vent clogged.	Remove air by bleeding (check compensating port for clearance of cup to provide full open port). Adjust brakes. Replace. See ALL BRAKES DRAG. Flush and bleed system using GM Hydraulic Brake Fluid Supreme No. 11 (or equivalent). Install new lining or replace shoe and lining.  Replace drums. Clean vent or replace cap; bleed brakes.

#### LOW PEDAL

Cause	Remedy
Hydraulic System Failure.  Self adjustors not working.  Low fluid level in master cylinder reservoir.	Check master cylinder for empty reservoir. Check for leak at master cylinder, wheel cylinder, hoses, metal pipes, and all connections. Inspect for incorrect installation or frozen adjuster screw and correct as necessary. Low fluid level in reservoir will permit air to be pumped into hydraulic lines. This necessitates refilling reservoir and bleeding lines. Find cause of low fluid and correct.



### LOW PEDAL

Cause	Remedy
<p>External leak in hydraulic system, or leak past master cylinder primary piston cup. Air trapped in hydraulic system.</p> <p>Incorrect fluid.</p> <p>Excessive clearance between linings and drum.</p>	<p>Check for leak in system as outlined above.</p> <p>Air trapped in hydraulic system gives pedal a very soft feel at the beginning of travel. Bleed brakes.</p> <p>Incorrect fluid may boil at high temperature. Flush system and refill with Brake Fluid No. 5464831 or equivalent. Adjust brakes.</p>

### \*BRAKES FADE

Cause	Remedy
<ol style="list-style-type: none"> <li>1. Incorrect lining.</li> <li>2. Thin drum.</li> <li>3. Dragging brakes.</li> </ol> <p>*Fade is a temporary reduction of brake effectiveness resulting from heat.</p>	<ol style="list-style-type: none"> <li>1. Replace with new lining.</li> <li>2. Replace drums.</li> <li>3. Adjust or correct cause.</li> </ol>

### ONE WHEEL DRAGS

Cause	Remedy
<p>Improperly adjusted parking brake cables or stuck cable. Weak or broken brake shoe return springs.</p> <p>Brake shoe to drum clearance too small.</p> <p>Wheel cylinder piston cups swollen or distorted or piston stuck.</p> <p>Obstruction in line.</p> <p>Backing plate shoe pad grooved.</p> <p>Incorrect brake shoe radius.</p>	<p>Adjust parking brake cables and lubricate.</p> <p>Replace defective brake shoe springs and lubricate brake shoe ledges and shoe contact at anchor pin with brake lubricant No. 1050110 or equivalent. Readjust brakes.</p> <p>Replace inoperative or damaged parts. Look for evidence of dirt in hydraulic system which could cause damage to the cylinders or cups. See first item under ALL BRAKES DRAG. Obstruction in line may be caused by foreign material or flattened or kinked tube. If dirt is found in line, remove obstruction and flush hydraulic system with fresh brake fluid. If tube is flattened or kinked, replace damaged parts. Grind or file pads smooth and lubricate with brake lubricant No. 1050110 or equivalent. Replace malfunctioning brake shoe.</p>

**BRAKES DO NOT AUTOMATICALLY ADJUST**

Cause	Remedy
<p>Worn, bent or distorted adjuster lever.</p> <p>Improper secondary lining to drum clearance.</p> <p>Brake linings excessively worn.</p>	<p>Replace adjuster lever.</p> <p>Adjust clearance.</p> <p>Install new linings.</p>

**VEHICLE PULLS TO ONE SIDE**

Cause	Remedy
<p>Grease or fluid on lining.</p> <p>Improper lining contact with drum.</p> <p>Wheel bearings excessively loose.</p> <p>Loose backing plate.</p> <p>Linings not to specifications, or primary and secondary shoes reversed. New and used linings mixed on one end of vehicle.</p> <p>Tires not properly inflated or unequal wear of tread. Different tread design.</p> <p>Linings charred or drums scored.</p> <p>Wheel cylinder link off shoe.</p> <p>Defective wheel cylinder.</p> <p>Obstruction in line.</p> <p>Water, mud, etc., in brakes.</p> <p>Loose steering gear, etc.</p> <p>Incorrect geometry setting of front suspension.</p> <p>Weak or broken retracting springs.</p> <p>Out-of-round drums.</p> <p>Clogged or crimped hydraulic line.</p>	<p>Replace with new linings. Linings with even a slight trace of grease or fluid may effect the operation of the brakes and can seldom be salvaged by cleaning. Correct cause of grease or fluid reaching linings.</p> <p>Grind or replace lining.</p> <p>Adjust wheel bearings.</p> <p>Tighten backing plate.</p> <p>Various kinds of linings have different frictional effects on the drums and on each other. Each wheel must have similar linings. The primary and secondary linings must not be interchanged. Use only factory specified linings.</p> <p>Inflate tires to specified pressures. Rearrange tires so that a pair with non-skid tread surfaces of similar design and equal wear will be installed on front wheels and pairs with like tread will be installed on rear wheels.</p> <p>Sand surfaces of linings and drums. Remove particles of metal that have become embedded in surfaces of linings. Seriously charred linings should be replaced.</p> <p>Check boot for holes. Check for burrs on wheel cylinder piston caused by piston forced against stop. Reinstall link.</p> <p>Repair or replace as required.</p> <p>Clear or replace as required.</p> <p>Remove any foreign material from all brake parts and the inside of drums. Lubricate shoe ledges and rear brake cable ramps with grease. Examine support assembly for damage.</p> <p>Adjust steering gear, etc.</p> <p>Adjust geometry so that vehicle does not have a tendency to lead when driven on a level road.</p> <p>Check springs-replace bent, open-coiled or cracked springs.</p> <p>Resurface or replace drums in left and right hand pairs (both front and both rear).</p> <p>Repair or replace line.</p>

## EXCESSIVE PEDAL PRESSURE REQUIRED TO STOP VEHICLE

Cause	Remedy
Brake adjustment not correct. Improper lining. Improper shoes. Grease or fluid soaked linings. Rusted wheel cylinder. Wheel cylinder link incorrectly aligned. Compensating port not cleared. Brake pedal binding on shaft.  Glazed linings. Bellmouthed, barrel-shaped or scored drums.	Adjust brakes. Install factory specified shoes. Install factory specified shoes. Correct cause and replace linings, if necessary. Replace. Check wheel cylinder piston and boot for damage. Install link. Check pedal linkage, stop light switch adjustment. Lubricate with Delco Brake Lube #5450032 (or equivalent). Sand surface of linings. Replace or resurface drums in left and right hand pairs.

## CRUNCH OR GROAN, HOLDING VEHICLE ON HILL

Cause	Remedy
Brake dust and possibly linings which have been overheated.	Sand linings and remove dust from brakes.

## HIGH PITCH SQUEAK WHILE BRAKES OPERATE

Cause	Remedy
New linings not yet fully burnished. Persistent squeak-no apparent cause.	Burnish further or sand off high spots of linings.  Sand linings for temporary cure or mild cases. Install drum springs for stubborn cases of high pitch squeak.

## REAR BRAKES DRAG

Probable Cause	Remedy
1. Maladjustment.  2. Parking brake cables frozen.	1. Adjust brake shoes and parking brake mechanism.  2. Lubricate with Delco Brake Lube #5450032 (or equivalent).

## ALL BRAKES DRAG OR PEDAL BUILDS UP WITH USE AFTER ADJUSTMENT IS CHECKED AND FOUND TO BE CORRECT

Cause	Remedy
<p>Mineral oil, etc., in system.</p> <p>Pedal does not return freely.</p> <p>Compensating port of master cylinder closed.</p>	<p>The presense in the hydraulic system of any mineral oil, kerosene, gasoline, shock absorber or transmission fluid, or carbon tetrachloride will cause swelling of rubber piston cups, and valves, so they become inoperative. This is first noticed in the master cylinder. Brakes will not release freely if master cylinder primary piston cup has swollen sufficiently to obstruct the compensating port. Flush system thoroughly with a good grade of clean brake fluid and replace all internal rubber parts in brake system.</p> <p>Lubricate pedal linkage and make certain no bind exists. See that stop light switch is not defective, incorrectly adjusted, or that switch plunger is not binding on pedal due to lack of lubrication. The compensating port in master cylinder must be completely clear when pedal is in released position.</p> <ol style="list-style-type: none"> <li>1. See that pedal returns freely and is not stopped by contact with stop light switch body or pedal bracket.</li> <li>2. See that compensating ports are not plugged by dirt. To check compensating port, remove master cylinder reservoir cover and watch the fluid in the cylinder as the brake pedal is moved. A "geyser" should be seen as the pedal is first depressed. If no geyser is seen, the compensating port is blocked.</li> <li>3. Inspect master cylinder primary piston cup and if found to be swollen or elongated, flush system and replace damaged parts.</li> </ol>

## LOUD LOW PITCH SQUEAL AT END OF HIGH RATE STOP

Cause	Remedy
<p>New linings not fully burnished. Angle on shoe web at adjusting screw notch.</p> <p>Bent backing plate. Top of shoe webs should be in line with each other looking down on them.</p> <p>Check after pushing shoes toward backing plate at top.</p> <p>Incorrect adjustment.</p>	<p>Check adjustment. Sand lining high spots. File straight.</p> <p>Straighten or replace.</p> <p>Adjust brakes. (NOTE: Drum springs not effective against low pitch squeal or howl.)</p>

### PEDAL THROB AT LIGHT APPLICATIONS AT LOW SPEED

Cause	Remedy
Drum out-of-round or off center.	Turn down.

### ROUGH FEEL DURING HIGH RATE STOPS FROM MODERATE SPEED

Cause	Remedy
Tool chatter. Look for faint light and darker stripes running across the braking surface.	Turn drum.

### LIGHT PEDAL PRESSURE—BRAKES TOO SEVERE

Cause	Remedy
Brake adjustment not correct. Loose support assembly.  Small amount of grease or fluid on linings. Charred linings or scored drums.       Improper linings.	Adjust brakes. Tighten rear backing plates. Adjust brakes. Correct cause and replace linings.  Sand surfaces of linings and drums. Clean loose dust from brake. In severe cases replace shoes. Warn owner regarding abuse of brakes. Remove all particles that have become imbedded in surfaces of linings. Slightly scored drums do not require replacing or turning. Install factory specified linings.

### SQUEAK IN BRAKE WITH VEHICLE STATIONARY (SOMETIMES MISTAKEN FOR PEDAL SQUEAK)

Cause	Remedy
Shoe pads on backing plates dry and rusty.	Pry shoes out with screwdriver-apply grease sparingly to shoe pads with feeler stock.

**CREAK WHEN BRAKES ARE APPLIED AT LOW VEHICLE SPEED**

Cause	Remedy
Anchor pins dry.	Grease anchor pins where shoes bear.

**SCRAPE IN BRAKES AS PEDAL IS APPLIED, VEHICLE STATIONARY**

Cause	Remedy
Hold-down nail heads dry.	Lubricate. Although adjusting brakes temporarily changes these noises, lubrication will remedy.

**PEDAL SQUEAK**

Cause	Remedy
Dry pedal bushings or stop light switch rubbing pedal.	Lubricate.

**CLICKS DURING HIGH RATE STOPS, USUALLY ONCE PER WHEEL REVOLUTION IN ONE WHEEL ONLY**

Cause	Remedy
Threaded drum.	Cross sand.

**CHATTER AT HIGH SPEED**

Cause	Remedy
Drum out-of-round with 2 or more distinct high spots in circumference.	Turn drum.

**CLICK FIRST APPLICATION AFTER REVERSING**

Cause	Remedy
Shoes out from anchor pins.	File shoe pads on backing plates; lubricate. Although adjusting brakes temporarily changes these noises, lubrication will remedy.

## TROUBLE DIAGNOSIS CHART

### SINGLE PISTON DISC BRAKES

#### PULLS

Cause	Correction
<p>Incorrect tire pressures.</p> <p>Front end out of line.</p> <p>Unmatched tires on front of vehicle.</p> <p>Restricted brake tubes or hoses.</p> <p>Malfunctioning caliper assembly.</p> <p>Defective or damaged shoe and lining (grease or brake fluid on lining or bent shoe).</p> <p>Malfunctioning rear brakes.</p> <p>Loose suspension parts.</p> <p>Loose calipers.</p>	<p>Inflate evenly on both sides to the recommended pressures.</p> <p>Check and align to specifications.</p> <p>Tires with approximately the same amount of tread should be used on the same axle.</p> <p>Check for soft hoses and damaged lines. Replace with new hoses and new double-walled steel brake tubing.</p> <p>Check for stuck or sluggish pistons, proper lubrication.</p> <p>Install new shoe and lining in complete axle sets.</p> <p>Check for inoperative auto adjusting mechanism, defective lining (grease or brake fluid on lining) or defective wheel cylinders. Repair as necessary.</p> <p>Check all suspension mountings.</p> <p>Check and torque bolts to specifications.</p>

#### BRAKE ROUGHNESS OR CHATTER (PEDAL PULSATES)

Cause	Correction
<p>Excessive lateral runout.</p> <p>Parallelism not within specifications.</p> <p>Rear drums out of round.</p> <p>Shoe reversed (steel against iron).</p>	<p>Check and replace or machine the rotor, if not within specifications.</p> <p>Check and replace or machine the rotor, if not within specifications.</p> <p>Check runout and, if not within specifications, turn the drums (not over maximum of 0.060" on the diameter).</p> <p>Replace shoe and lining and machine rotor within specifications.</p>

#### EXCESSIVE PEDAL EFFORT

Cause	Correction
<p>Malfunctioning power brake.</p> <p>Partial system failure.</p>	<p>Check power brake and repair if necessary.</p> <p>Check front and rear brake system and repair, if necessary. Also check brake warning light, if a failed system is found and light did not function, repair as necessary.</p>

**EXCESSIVE PEDAL EFFORT**

Cause	Correction
<p>Excessively worn shoe and lining. Piston in caliper stuck or sluggish. Fading brakes due to incorrect lining.</p>	<p>Check and replace in axle sets. Remove caliper and rebuild or replace.  Remove and replace with original equipment lining.</p>

**EXCESSIVE PEDAL TRAVEL**

Cause	Correction
<p>Partial brake system failure.  Insufficient fluid in master cylinder. Air trapped in system. Rear brake not adjusting. Bent shoe and lining.</p>	<p>Check both front and rear system for a failure and repair. Also, check warning light. It should have indicated a failure. Fill reservoirs with approved brake fluid. Check for leaks. Check warning light. Bleed system. Adjust rear brakes and repair adjusters. Replace axle set of shoe and lining.</p>

**GRABBING OR UNEVEN BRAKING ACTION**

Cause	Correction
<p>All conditions listed under "PULLS." Malfunction of combination valve. Malfunction of power brake unit.</p>	<p>All corrections listed under "PULLS."  Replace and bleed system. Check operation and repair, if necessary.</p>

**DRAGGING BRAKES**

Cause	Correction
<p>(NOTE: A very light drag is present in all disc brakes immediately after pedal is released.)</p> <p>Master cylinder pistons not returning correctly.</p> <p>Restricted brake tubes or hoses.</p> <p>Incorrect parking brake adjustment on rear brakes.</p>	<p>With reservoir cover off, check for fluid spurt at bypass holes as pedal is depressed. Check power cylinder push rod, if necessary, or rebuild master cylinder. Check for soft hoses or damaged tubes and replace with new hoses and new double-walled steel brake tubing. Check and readjust to correct specifications.</p>



# POWER CYLINDER TROUBLE DIAGNOSIS CHART

Before checking the power brake system for the source of trouble, refer to the trouble diagnosis of drum and disc brakes. After these possible causes have been eliminated, check for the cause as outlined in the following chart:

## BRAKES FAIL TO RELEASE

Cause	Correction
Blocked passage in diaphragm plate Air valve sticking shut. Broken piston return spring. Broken air valve spring. Tight pedal linkage.	Inspect and repair or replace as necessary. Check for proper lubrication of air valve "O" ring. Replace. Replace. Repair or replace as necessary.

## HARD PEDAL

Cause	Correction
Broken or damaged hydraulic brake lines. Vacuum Failure.  Defective diaphragm. Restricted air filter element. Worn or badly-distorted reaction disc. Incorrect reaction disc.	Inspect and replace as necessary.  Check for: Faulty vacuum check valve or grommet-replace. Collapsed or damaged vacuum hose-replace. Plugged or loose vacuum fitting-repair. Faulty air valve seal or support plate seal-replace. Damaged control valve-replace. Bad stud welds on front or rear housing or power head-replace, unless easily repaired. Replace. Replace. Replace reaction disc.  Replace with correct disc.

## GRABBY BRAKES

### (Apparent Off-On Condition)

Cause	Correction
Broken or damaged hydraulic brake lines. Insufficient fluid in master cylinder Defective master cylinder seals. Cracked master cylinder casting. Leaks at front disc brake calipers or rear wheel cylinders in pipes or connections. Air in hydraulic system.	Inspect and replace as necessary.  Fill reservoirs with approved brake fluid, check for leaks. Repair or replace as necessary. Replace. Inspect and repair as necessary.  Bleed system.

## ON-VEHICLE SERVICING

### BLEEDING BRAKE SYSTEM

A bleeding operation is necessary to remove air whenever it is introduced into the hydraulic brake system. Since air is compressible and hydraulic fluid is not, the presence of air in the system is indicated by a springy, spongy feeling of the brake pedal accompanied by poor braking action.

Air can be introduced into the hydraulic system if the brake pedal is operated when the fluid is too low in master cylinder reservoir. Air will also enter the system whenever any part of hydraulic system is disconnected.

It may be necessary to bleed the hydraulic system at all six wheels if air has been introduced through low fluid level or by disconnecting brake lines at master cylinder. If the brake line is disconnected at

any wheel cylinder, then that wheel cylinder only need be bled. If lines are disconnected at any fitting located between master cylinder and wheel cylinders, then all wheel cylinders served by the disconnected line must be bled.

### SEQUENCE FOR BLEEDING WHEEL CYLINDERS

It is advisable to bleed one wheel cylinder at a time to avoid allowing fluid level in reservoir to become dangerously low. For the proper sequence refer to Figure 1.

Do not perform bleeding operation while any brake drum or disc pad is removed.

### BLEEDING WHEEL CYLINDER WITHOUT PRESSURE TANK

1. Fill master cylinder.

2. Install bleeder wrench on bleeder valve. Slip a brake bleeder hose over ball of wheel cylinder bleeder valve (See figure 2). Place lower end of bleeder tube in a glass jar that is partially filled with clean brake fluid. Position end of tube so that it will remain

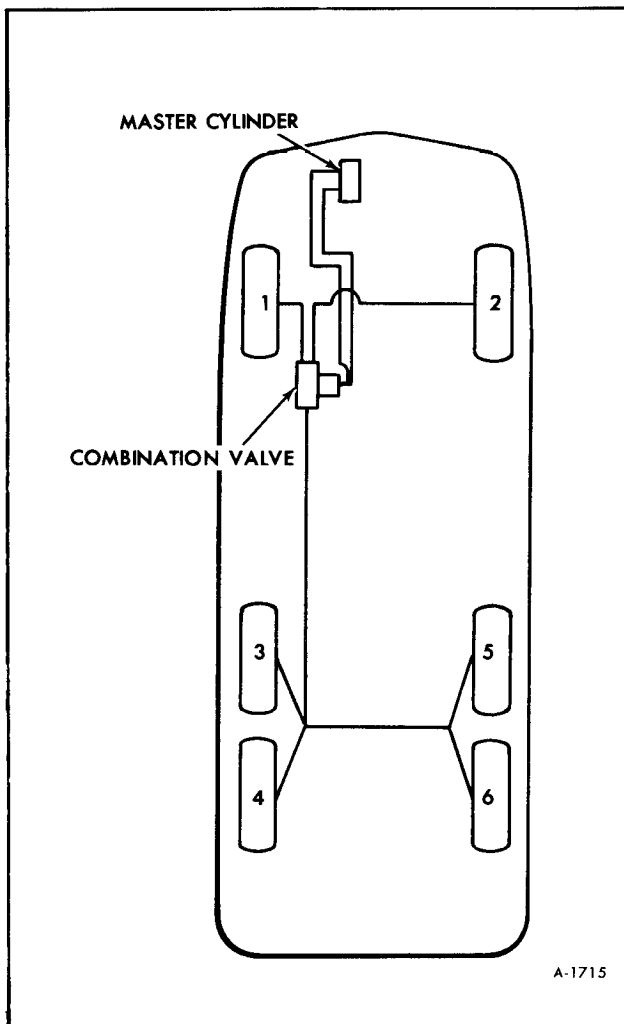

Figure 1—Brake Bleeding Sequence

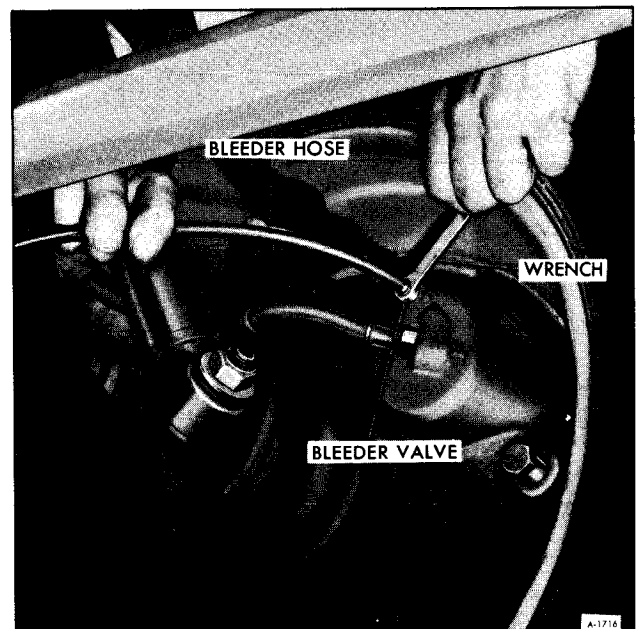

Figure 2—Brake Bleeder Wrench and Hose

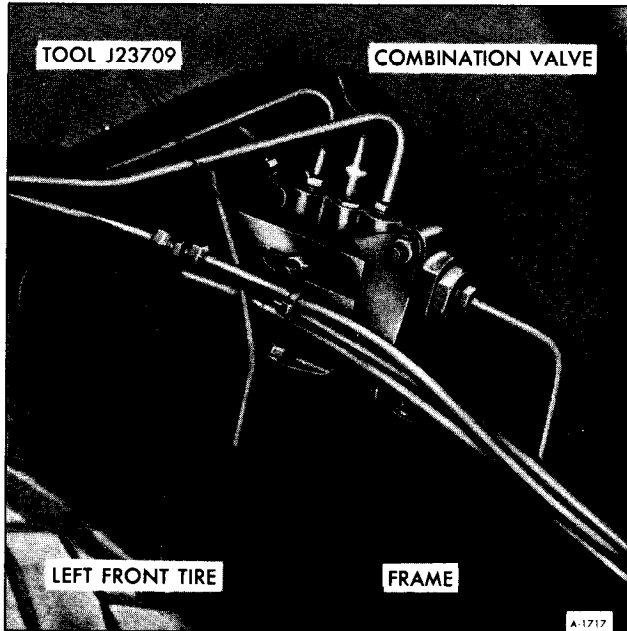

Figure 3—Tool J-23709 Installed

submerged under fluid during bleeding operation. Unscrew bleeder valve  $3/4$  of a turn.

Attach J-23709 to the combination valve (figure 3) to hold the push rod in and allow the pressure in the line to flow through the valve requiring less pressure to bleed the front cylinders.

3. Depress brake pedal a full stroke, close bleeder valve, then allow pedal to return slowly to released position. Allowing pedal to return quickly may draw air into system. Continue operating pedal in this manner until fluid flows from bleeder tube into glass jar in a solid stream that is free of air bubbles, then close the bleeder valve securely and remove bleeder tube and wrench.

4. Frequently check master cylinder to make sure that it contains fluid. Allowing reservoir to be emptied will cause air to be drawn into hydraulic system.

5. When bleeding operation is completed at all wheel cylinders where needed, make sure that fluid level is no more than  $1/4$ " below lip of reservoir, then install rubber diaphragm and cover.

6. Discard the brake fluid deposited in glass jar during bleeding operation.

## BLEEDING WHEEL CYLINDER WITH PRESSURE TANK

When using a pressure tank, air bubbles may form in the tank and enter the brake hydraulic sys-

tem. To avoid this, observe the following points when handling a pressure tank: (1) Do not shake or agitate the pressure tank after air pressure has been added or is being added. (2) Allow pressure tank to stand in one position as much as possible and bring air hose over to tank when adding head of air. (3) Make certain the valves on the pressure tank lines are not defective, allowing air to be sucked in when fluid passes through the lines. (4) Pressure tank should be kept at least  $1/3$  full of fluid to avoid air bubbles forming. (5) If pressure tank is full of air bubbles, release air pressure and those bubbles will increase in size, be forced to top of fluid and escape.

It is recommended that pressure bleeding equipment must be of the diaphragm type; that is, it must have a rubber diaphragm between the air supply and the brake fluid to prevent air, moisture, oil, and other contaminants from entering the hydraulic system.

1. Thoroughly clean master cylinder reservoir cover and surrounding area; then remove cover and diaphragm.

2. Make sure that pressure tank is at least  $1/3$  full of specified brake fluid and that hose and master cylinder reservoir are filled with fluid. Attach hose to master cylinder reservoir adapter.

3. Install Bleeder Wrench on bleeder valve. Slip a brake bleeder tube over ball of wheel cylinder bleeder valve (figure 2). Place lower end of bleeder tube in a clean glass jar. Unscrew bleeder valve  $3/4$  of a turn.

Attach J-23709 to the combination valve to hold the push rod in and allow the pressure in the line to flow through the valve (figure 3).

4. Open pressure tank hose valve to apply fluid to master cylinder under pressure that does not exceed 35 pounds. It is not necessary to pump the brake pedal when using pressure tank.

5. When fluid flows from bleeder tube into glass jar in a solid stream that is free of air bubbles, that particular cylinder and line are bled; tighten bleeder valve securely and remove bleeder tube.

6. When bleeding operation is completed at all wheel cylinders, where needed, make sure that fluid level is  $1/4$ " from the lowest portion of the top of each reservoir. Install rubber diaphragm and cover.

## FLUSHING BRAKE HYDRAULIC SYSTEM

It is recommended that the entire hydraulic system be thoroughly flushed with clean brake fluid

whenever new parts are installed in the hydraulic system.

Flushing is also recommended if there is any doubt as to the grade of fluid in the system or if fluid has been used which contains the slightest trace of mineral oil.

Flushing is performed at each wheel cylinder in turn, and in the same manner as the bleeding operation except that bleeder valve is opened 1-1/2 turns and the fluid is forced through the pipes and wheel cylinder until it emerges clear in color. Approximately two quarts of fluid is required to flush the hydraulic system thoroughly.

When flushing is completed at all wheel cylinders, make certain that master cylinder reservoir is filled to proper level.

## PARKING BRAKE ADJUSTMENT

Normal driver adjustment of the parking brake can be done at the parking brake lever. The knob on top of the lever can be used to increase or decrease the tension on the cable (figure 4).

If the tension on the cable cannot be adjusted at the lever it should be adjusted at the intermediate equalizer.

1. Turn the adjusting knob on top of parking brake lever counterclockwise until it comes up against its stop.

2. Apply and release parking brake lever.

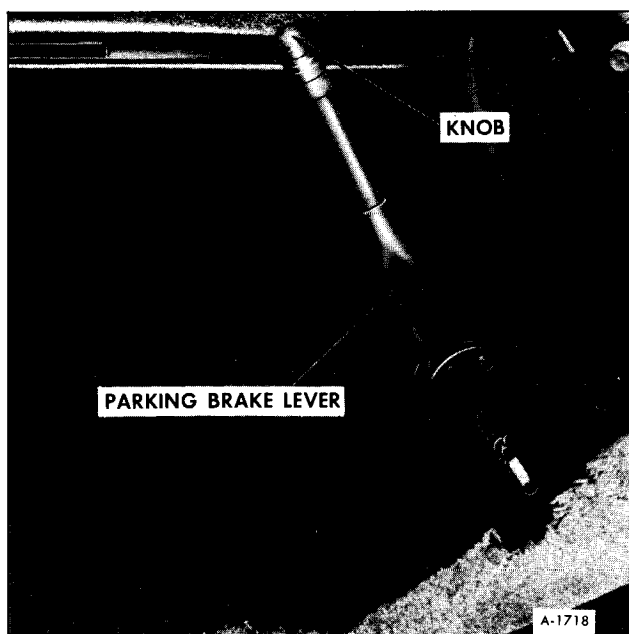

Figure 4—Parking Brake Lever Knob

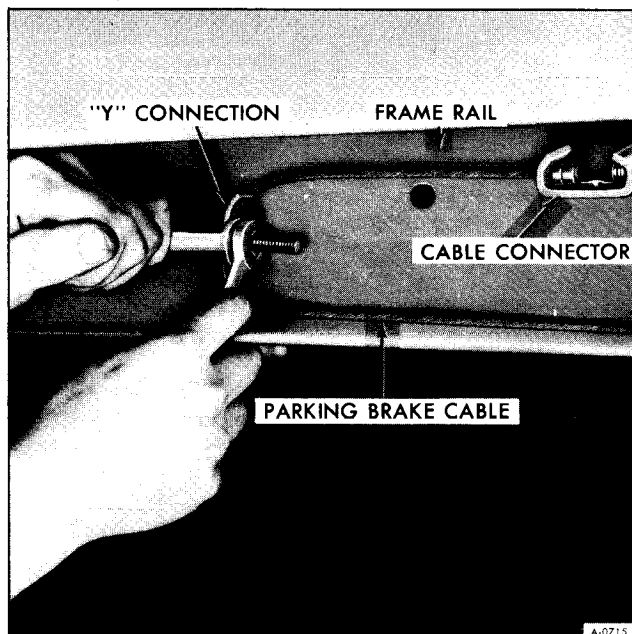

Figure 5—Loosening Intermediate Adjusting Nuts

3. Jack up rear wheels.

4. Loosen lock nut at intermediate cable equalizer as shown in Figure 5 and adjust front nut to give light drag at rear wheels.

5. Back off front nut until drag is just removed and lock.

6. Apply lever and re-adjust parking brake lever knob to give a definite snap-over-center feel.

7. Fully release parking brake and rotate rear wheels. No drag should be present.

8. Lower vehicle to floor.

## BRAKE SHOE ADJUSTMENT (DRUM INSTALLED)

1. If shoes are being adjusted for the first time a suitable punch, is used to knock out lanced area in brake backing plate, refer to Figure 6. If this is done with the drum installed on Motor Home, the drum must be removed and all metal cleaned out of the brake assembly. Be sure to procure a new hole cover and install it in the backing plate after adjustment to prevent dirt and water from getting into brakes. Use J-4735 to turn brake adjusting screw; expand brake shoes at each wheel until the wheel can just be turned by hand. The drag should be equal at all wheels.

2. Back off brake adjusting screw (figure 7) at each wheel 30 notches. If shoes drag lightly on drum,



Figure 6-Lanced Area in Backing Plate

back off adjusting screw one or two additional notches.

**NOTE:** Brake should be free of drag when screw has been backed off approximately 12 notches. Heavy drag at this point indicates tight parking brake cables.

3. Install adjusting hole cover in brake backing plate when adjustment is completed.

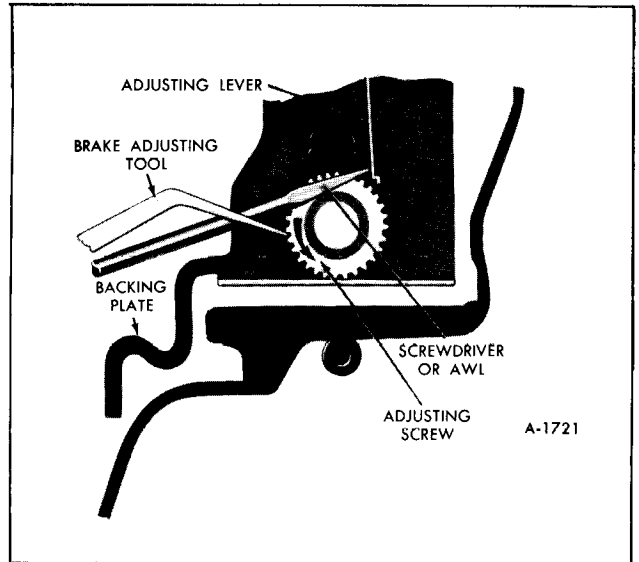

Figure 7-Backing Off Brake Adjustment

4. Check parking brake adjustment as described earlier in this section.

## DISC BRAKE ADJUSTMENT

The disc brakes on the front of the Motor Home require no periodic adjustment. They are adjusted with each brake application. As the piston in the caliper compensates for wear of the brake lining it requires more fluid. For this reason the master cylinder fluid level should be checked frequently.

## COMPONENT REMOVAL

### BRAKE DRUM REMOVAL

1. Hoist rear wheels off ground.

**NOTE:** It may be necessary to back off the brake shoe adjustment before the brake drum can be removed. To back off brake shoe adjustment, refer to Figure 7.

2. Remove wheel and tire.

3. Remove dust cap as shown in Figure 8.

4. Remove cotter pin and castellated nut from hub as shown in Figure 9.

5. Hub and drum assembly can now be removed. See Figure 10.

### REAR BRAKE SHOE REMOVAL (FIGURE 11)

1. Hoist vehicle remove wheel and brake drum.

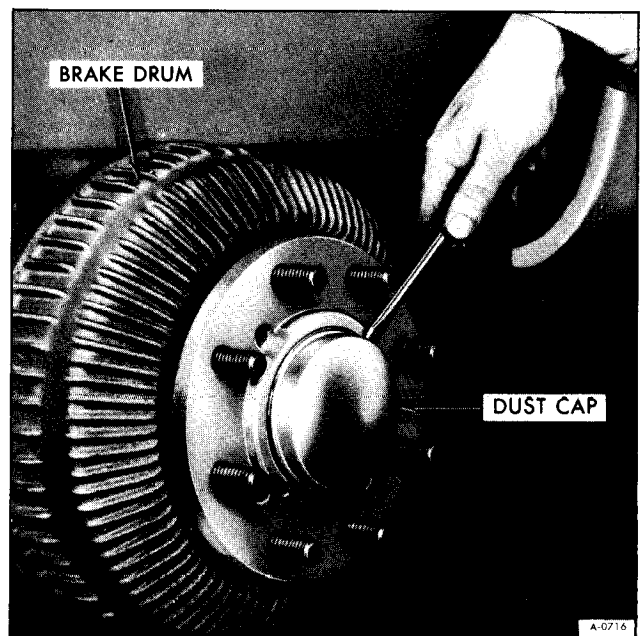

Figure 8-Removing Dust Cap

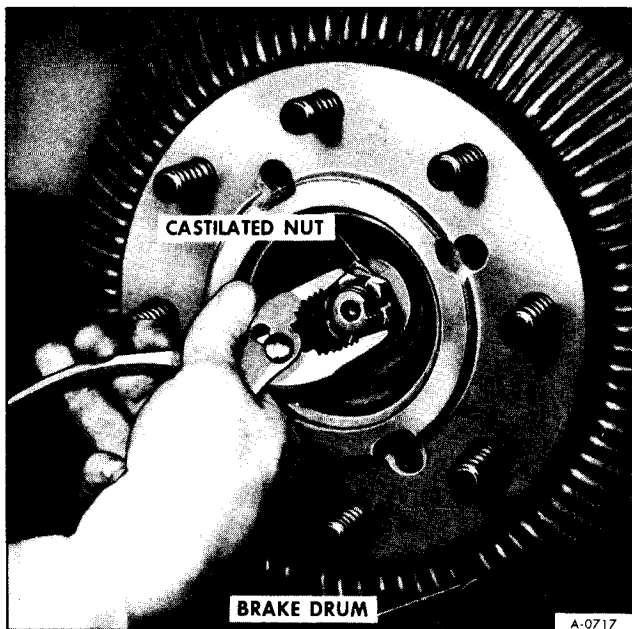

Figure 9—Removing Castillated Nut

2. Remove the brake shoe return springs actuating link and guide.
3. Remove the brake shoe hold-down springs, the adjuster lever and return spring and the parking brake lever strut and spring.
4. Spread shoes to clear wheel cylinder links then remove the brake shoes as an assembly.
5. Disconnect the parking brake cable from the operating lever.

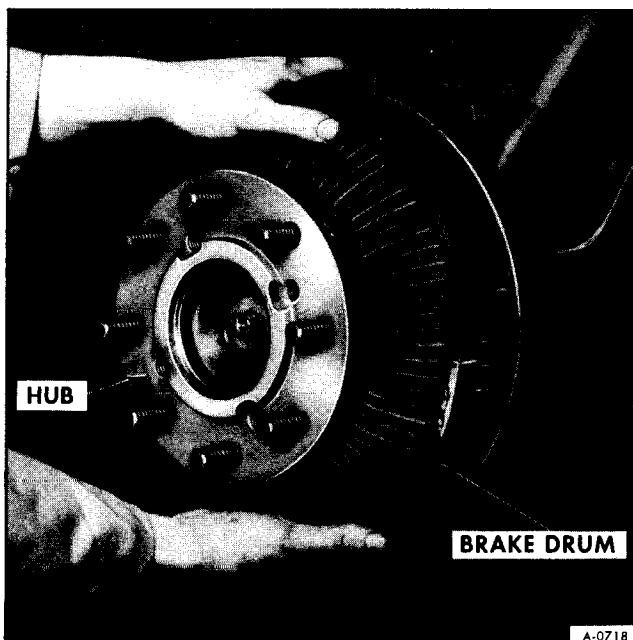

Figure 10—Removing Hub and Drum

## DISC BRAKE SHOE REMOVAL

1. Remove caliper as described later in this section under "Disc Removal."
2. Remove inboard shoe.
3. Remove outboard shoe.
4. Remove pad support spring from inboard shoe.
5. Remove sleeves from inboard ears of caliper.
6. Remove the rubber bushing from the grooves in each of the four caliper ears (figure 12).

## COMBINATION VALVE REMOVAL (FIGURE 13)

No attempt should be made to disassemble or repair the valve. If any failure should occur, the complete valve should be replaced.

1. Disconnect all brake lines at valve. Plug lines to prevent loss of fluid and entrance of dirt.
2. Disconnect warning switch wiring connector from valve switch terminal.
3. Remove valve assembly from mounting bracket.

## MASTER CYLINDER REMOVAL

The master cylinder can be removed without removing the power cylinder.

1. Be sure area around master cylinder is clean, then disconnect the hydraulic lines at the master cylinder (Refer to figure 14). Plug or tape ends of lines to prevent entrance of dirt or loss of brake fluid.
2. Remove two master cylinder attaching nuts and remove master cylinder as shown in Figure 15.

## DISC REMOVAL

1. Siphon approximately two-thirds of the brake fluid from the front reservoir of the master cylinder. Discard fluid.

**NOTE:** Do not empty front reservoir or it will be necessary to bleed the brake system.

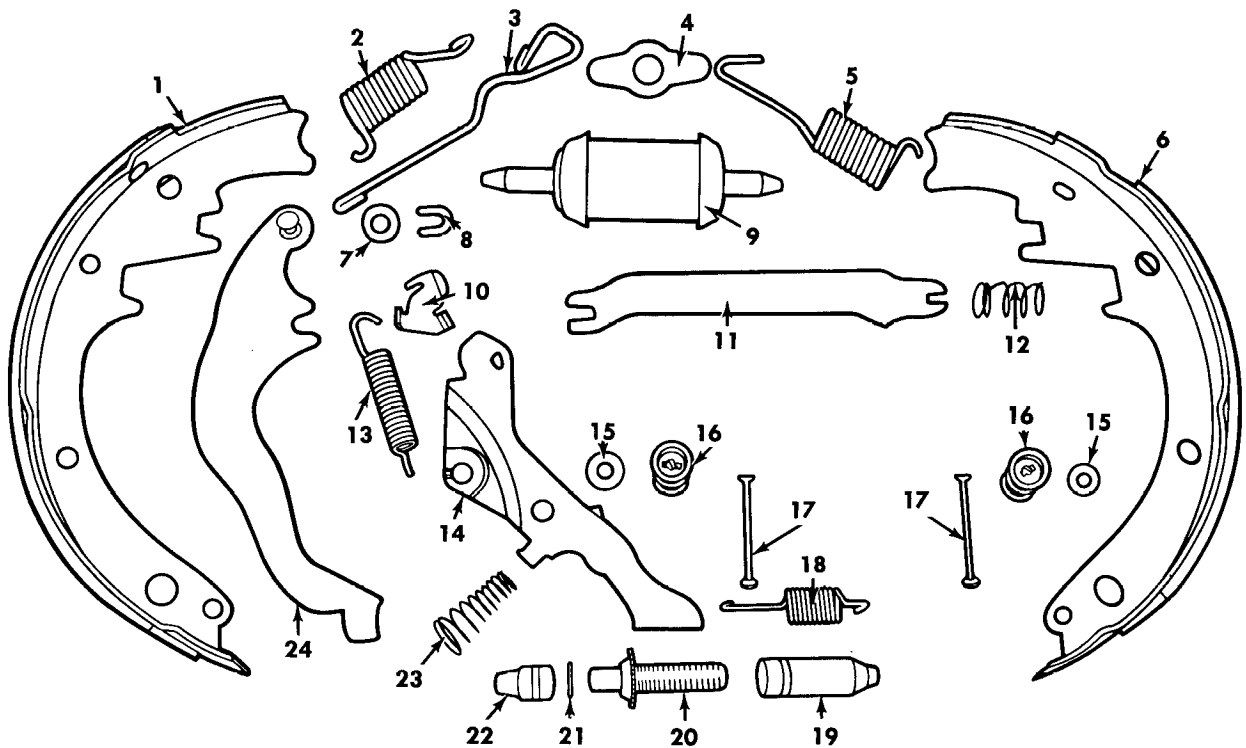

- |                              |                      |
|------------------------------|----------------------|
| 1. Secondary Shoe And Lining | 13. Override Spring  |
| 2. Return Spring             | 14. Adjuster Lever   |
| 3. Actuating Link            | 15. Washer           |
| 4. Guide Plate               | 16. Hold Down Spring |
| 5. Return Spring             | 17. Pin              |
| 6. Primary Shoe And Lining   | 18. Spring           |
| 7. Washer                    | 19. Nut              |
| 8. Clip                      | 20. Adjusting Screw  |
| 9. Wheel Cylinder            | 21. Washer           |
| 10. Pivot                    | 22. Socket           |
| 11. Strut                    | 23. Return Spring    |
| 12. Spring                   | 24. Lever            |

A-1725

Figure 11—Brake Assembly (Rear)

2. Hoist Motor Home and remove wheel.

3. Remove cotter pin, and drive axle nut and washer.

4. Position Tool J-22269 on caliper as shown in Figure 16.

5. Tighten screw of tool until caliper moves out-board far enough to push piston to bottom of piston bore. This will allow the shoes to back off from disc surface. Remove Tool J-22269.

6. Remove the two caliper to knuckle attaching bolts.

7. Carefully lift caliper assembly from disc and position so that brake hose is not kinked or stretched.

8. Loosen uniformly and remove the three bolts securing the retainer to the knuckle (figure 17).

9. Position tool No. J-24717 on hub as shown in Figure 18.

10. Operate slide hammer, tool No. J-2619, until assembly is free of knuckle.

11. Remove slide hammer and tool No. J-24717.

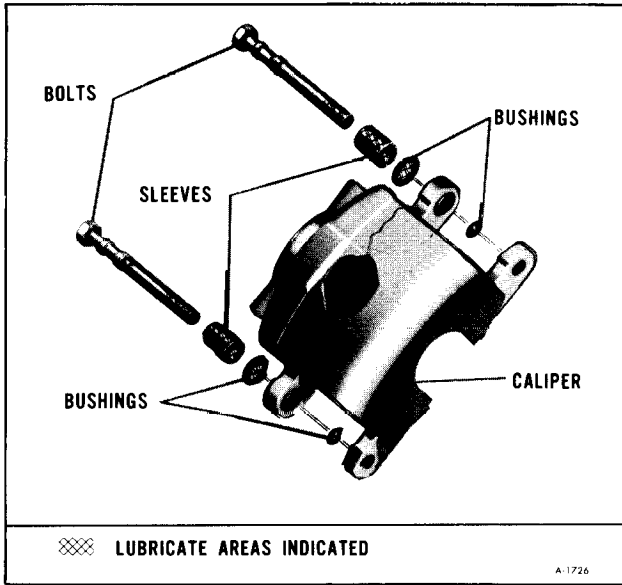

Figure 12—Caliper Sleeve and Bushing Location

12. Assemble tool No. J-23345 to tool No. J-8433-1.

13. Position tool assembly as shown in Figure 19.

14. With tool No. J-22214-6 in place, and a clamp in position tighten center screw until bearing is free of hub.

15. Remove seal and retainer.

16. Remove four bolts and separate disc from hub as shown in Figure 58.

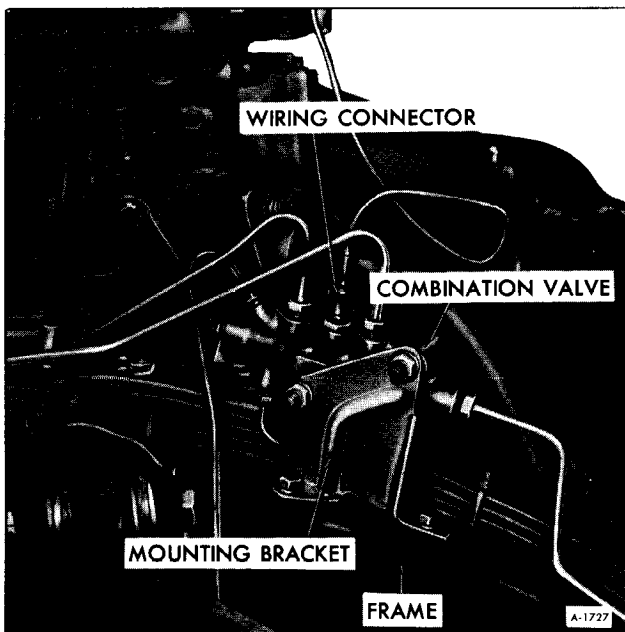

Figure 13—Combination Valve Mounting

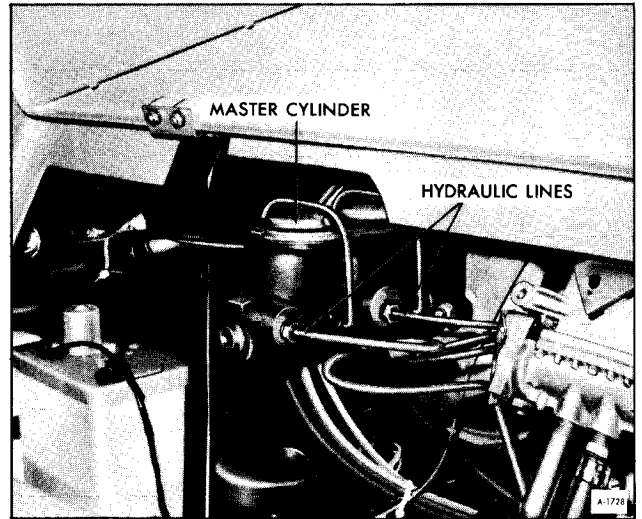

Figure 14—Hydraulic Lines at Master Cylinder

## POWER BRAKE BOOSTER REMOVAL

1. Remove four (4) screws from power level control panel.

2. Pull panel and valve assemblies out of the way, as shown in Figure 20.

3. Remove clevis pin from brake pedal (Refer to figure 21).

4. Remove master cylinder, see "Master Cylinder Removal" earlier in this section.

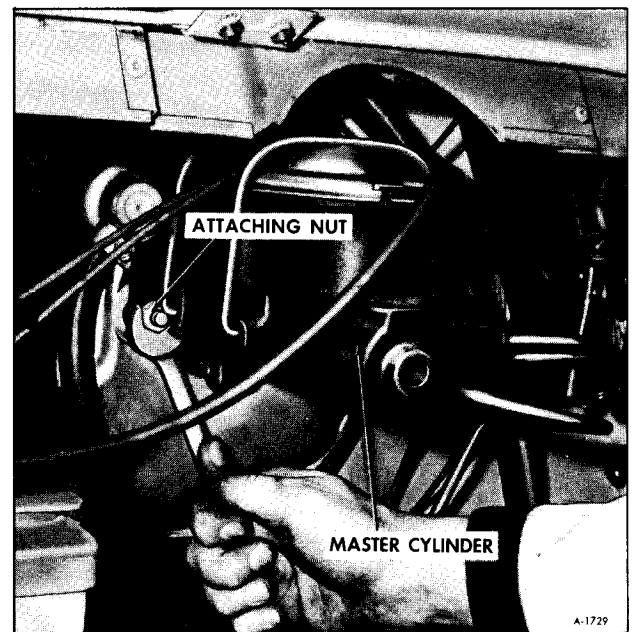

Figure 15—Removing Master Cylinder



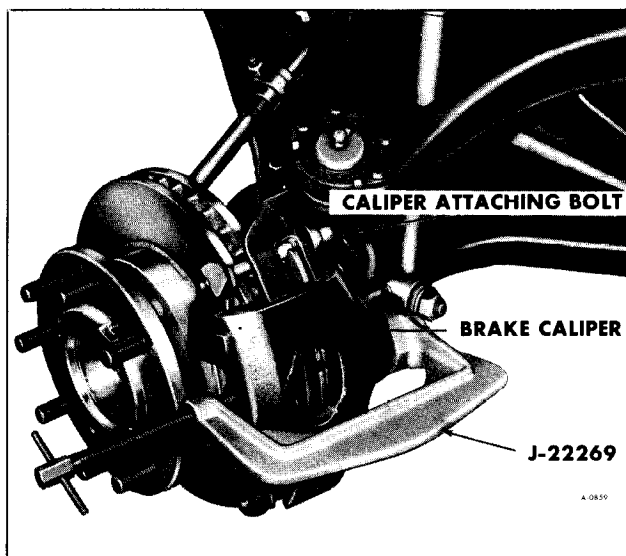

Figure 16—Tool J-22269 on Caliper

5. Remove master cylinder bracket by removing two bolts from top of bracket.

6. Remove vacuum line to power brake booster.

7. Remove four nuts retaining booster assembly to firewall, as shown in Figure 22.

8. Remove booster assembly through left front access door.

## PARKING BRAKE LEVER REMOVAL

1. Remove four nuts and bolts retaining lever to toe board (Refer to figure 23).

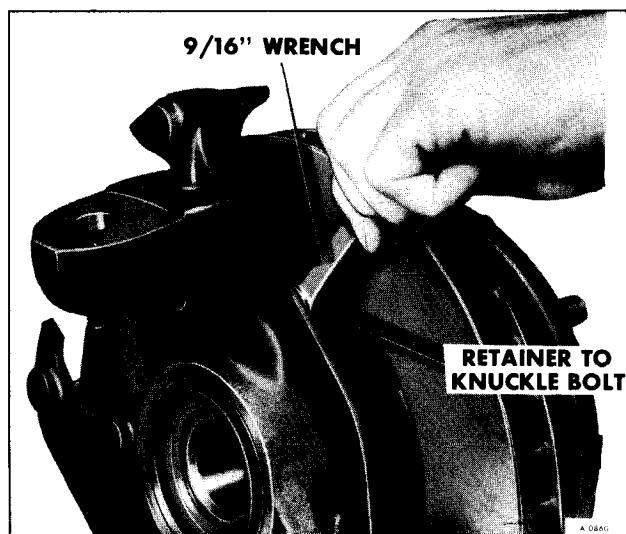

Figure 17—Removing Retainer from Knuckle

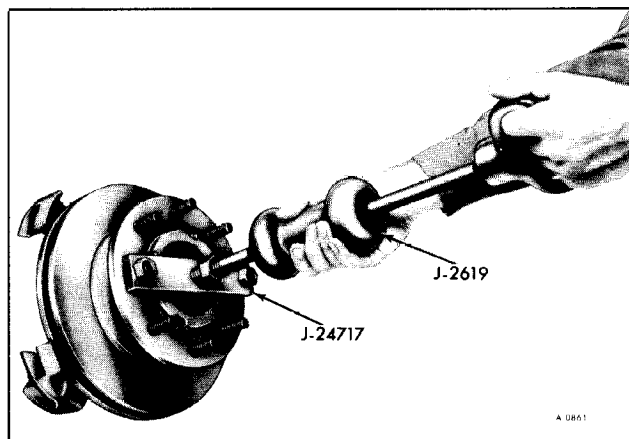

Figure 18—Installing Tool J-24717

2. Remove two nuts and bolts on cable retaining bracket, as shown in Figure 24.

3. Remove pin from bracket retaining cable end.

4. Remove one screw holding switch to parking brake lever.

5. Remove lever.

## FRONT PARKING BRAKE CABLE REMOVAL

1. Raise Motor Home with suitable lifting device.

2. Remove lock nut and adjusting nut from front equalizer (Refer to figure 25).

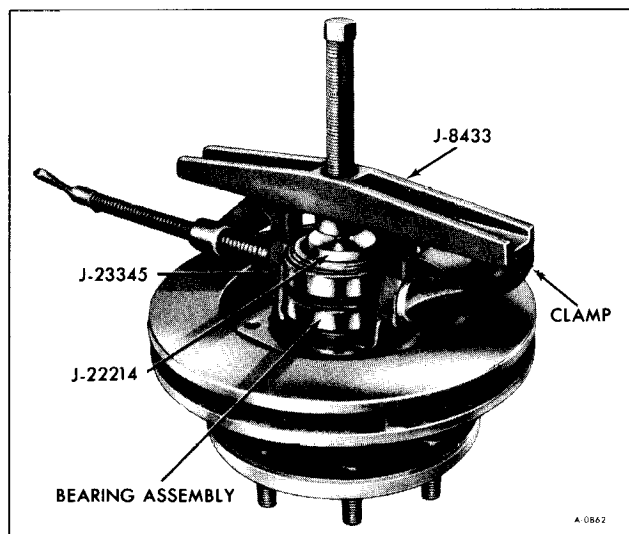

Figure 19—Bearing Removal

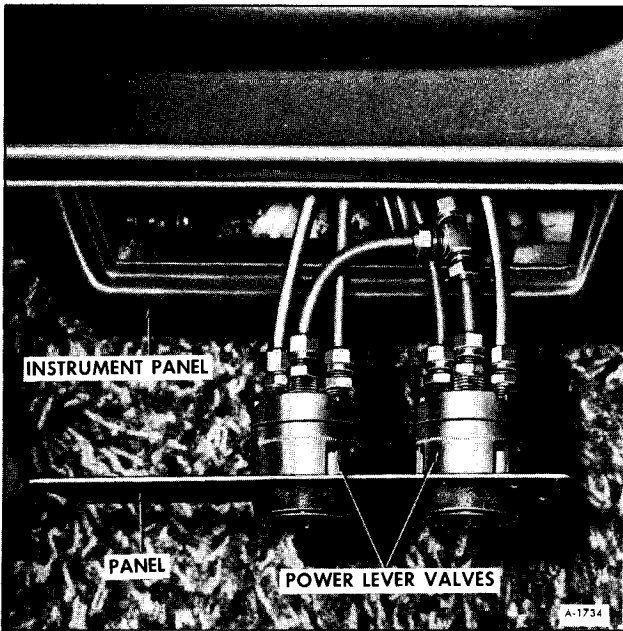

Figure 20—Power Level Panel Removed

3. Remove cable clip at shift relay bracket.
4. Remove retaining pin in parking brake lever.
5. Remove cable.

## INTERMEDIATE PARKING BRAKE CABLE REMOVAL

1. Hoist vehicle.

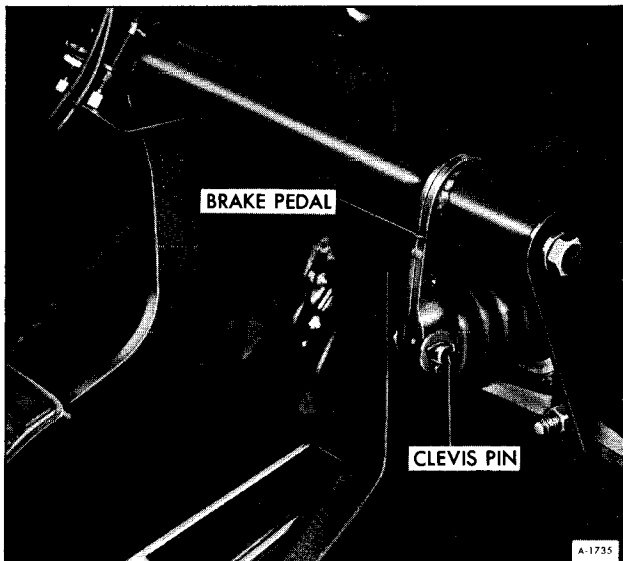

Figure 21—Clevis Pin Location

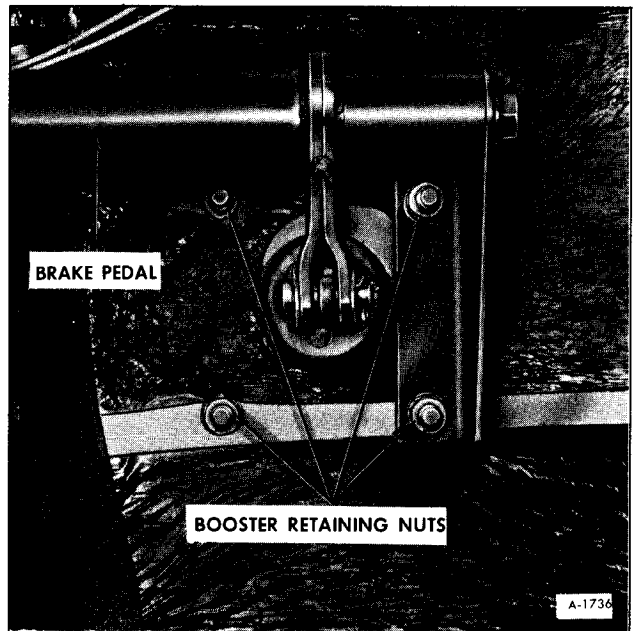

Figure 22—Booster Assembly Retaining Nuts

2. Remove lock nut and adjusting nut from two intermediate equalizers on the outside of each frame rail (Refer to figure 5).
3. Remove lock nut and adjusting nut from front equalizer as shown in Figure 25.
4. Disconnect cable from guide on frame cross-member (figure 26).



Figure 23—Removing Parking Brake Lever Retaining Nuts

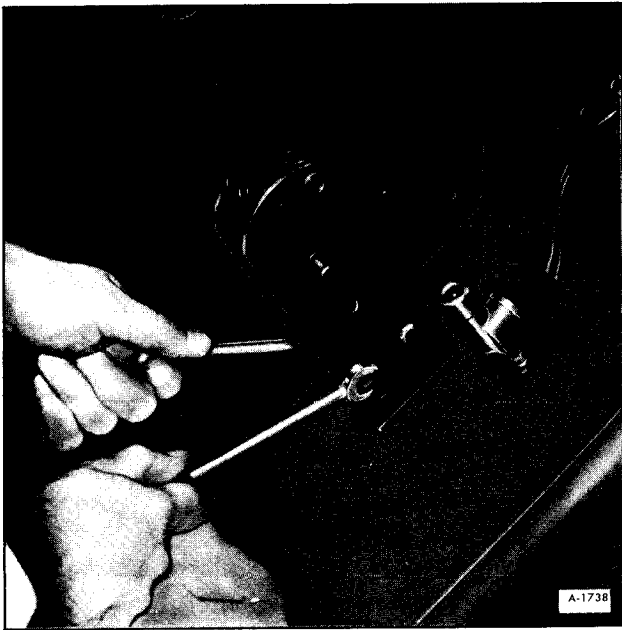

Figure 24—Removing Cable Retaining Bracket

5. Disconnect cable from guides at points where cable passes through frame rails as shown in Figure 27.

6. Remove cable.

## REAR PARKING BRAKE CABLE REMOVAL

1. Disconnect intermediate equalizer by remov-

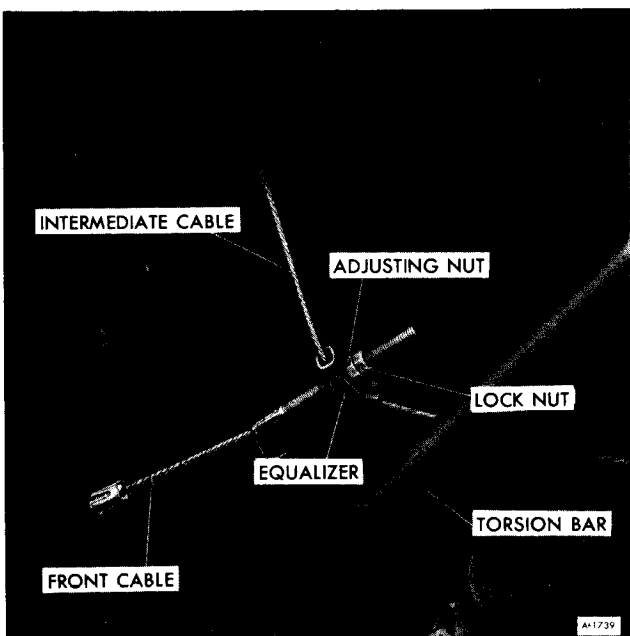

Figure 25—Parking Brake Cable

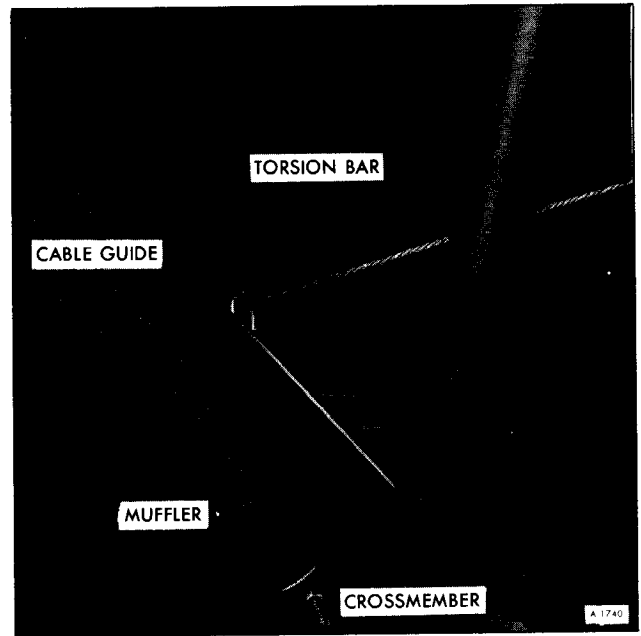

Figure 26—Cable Guide on Crossmember

ing locking and adjusting nuts (figure 5).

2. Pull wire clips at retainers on frame rails (See figure 28).

3. Remove ends of cables from cable connectors. Feed ends of cables through retainers on frame rails.

4. Remove hubs and drums.

5. Release end of cable from parking brake lever.

6. Compress the locking fingers and pull the rear cable from the backing plate refer to Figure 29.

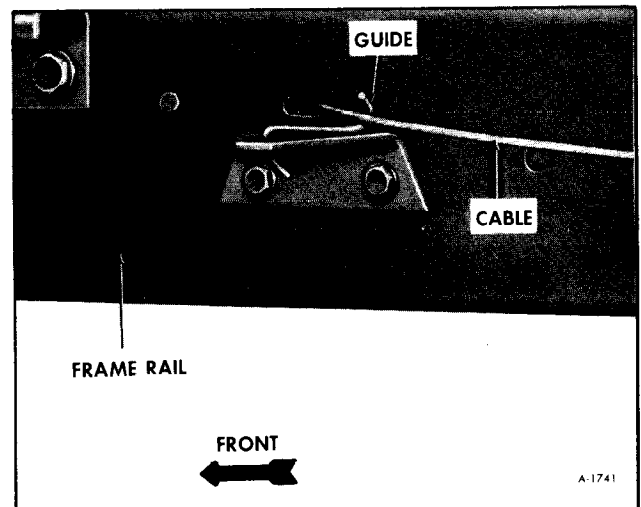

Figure 27—Cable Guide on Frame Rail

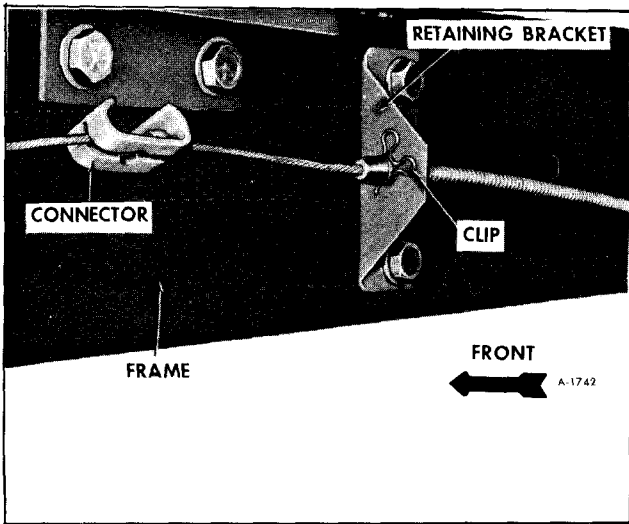

Figure 28—Clip on Frame Rail Retaining Bracket

## BRAKE PEDAL REMOVAL

1. Remove four screws from power lever control mounting panel, and pull valves and panel out (figure 20).
2. Remove stop light switch from top of brake pedal. If equipped with cruise control remove the switch next to the stop light switch (figure 30).
3. Remove cotter pin from pin retaining power

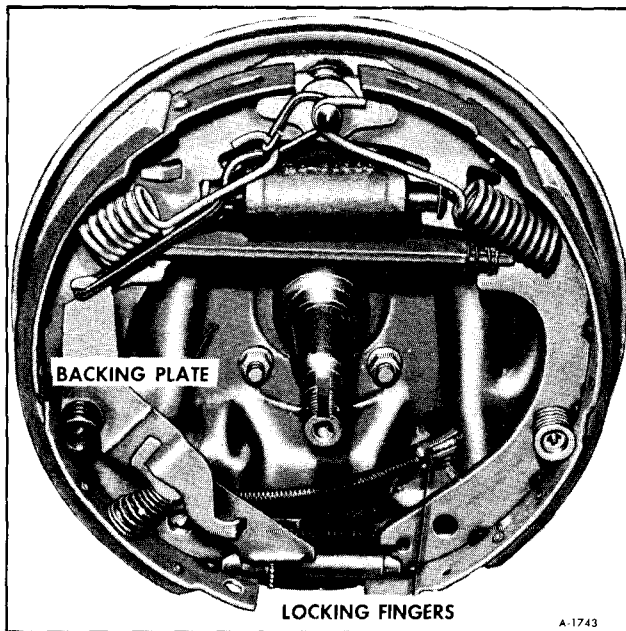

Figure 29—Locking Fingers

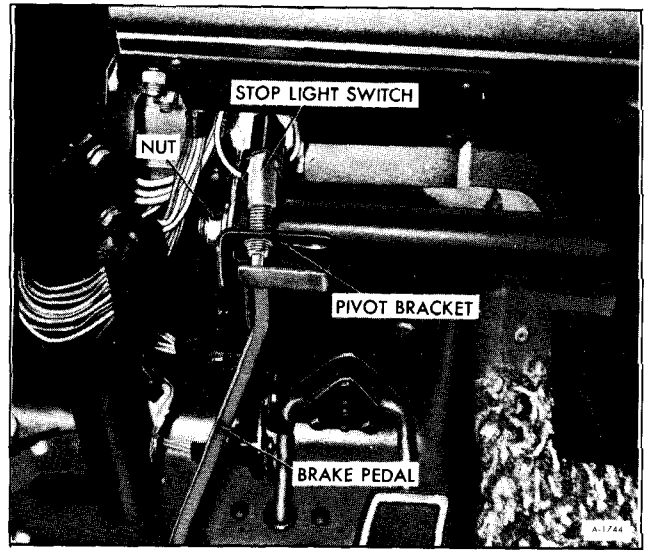

Figure 30—Brake Pedal Assembly (Left Side)

4. Remove nuts from each end of pedal assembly (figure 31).
5. Loosen left-hand brake lever pivot bracket.
6. Remove brake pedal assembly.

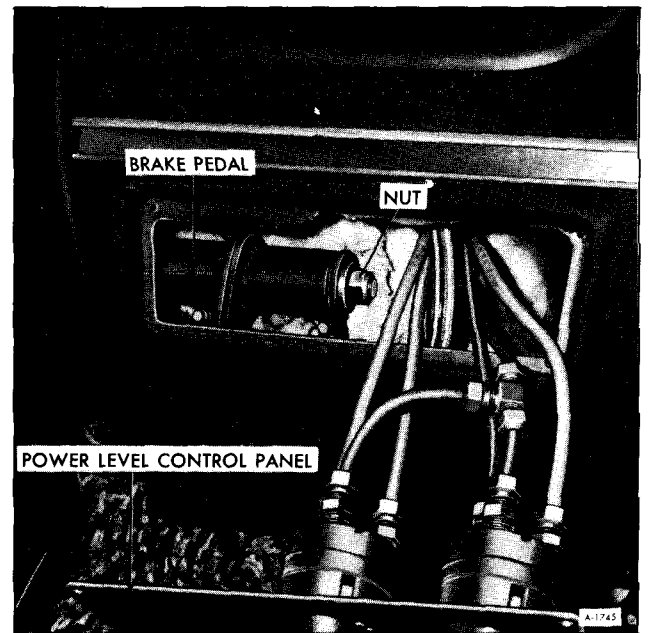

Figure 31—Brake Pedal Assembly (Right Side)

# COMPONENT OVERHAUL

## MASTER CYLINDER OVERHAUL

### DISASSEMBLY (FIGURE 32)

1. Remove the small secondary piston stop screw from the bottom of the front fluid reservoir of the master cylinder.

2. Place the master cylinder in the vise so that the lock ring can be removed from the small groove in the I.D. of the bore. Remove the lock ring and primary piston assembly. Remove the secondary piston, secondary piston spring and retainer by blowing air through the stop screw hole. If air is not available, a piece of wire may be used. Bend approximately 1/4" of one end of the wire into a right angle. Hook this end under the edge of the secondary piston and pull the secondary piston from the bore.

**NOTE:** The brass tube-fitting insert need not be removed unless visual inspection indicates the insert is damaged.

3. To replace a defective insert or check valve, the following procedure should be practiced:

a. Place the master cylinder in a vise, so that the outlet holes are up. Enlarge the outlet holes in the tube seats using a 13/64" drill. Tap a 1/4"-20 thread in these holes. Place a heavy washer over the outlet on the master cylinder and thread a 1/4"-20 x 3/4" hex head bolt into the tube seat. Tighten the bolt until the tube seat is unseated.

b. A more preferable way to remove a defective insert involves use of a self-tapping screw and a claw hammer. With a box-end or socket wrench, thread a #6-32 x 5/8" long self-tapping screw into the tube-fitting insert. Using the claw end of the hammer, remove the screw and insert.

4. Remove the casting from the vise and inspect the bore for corrosion, pits and foreign matter. Be sure the outlet ports are clean. Inspect the fluid reservoirs for foreign matter. Check the bypass and compensating ports to the master cylinder bore to determine if they are restricted.

## MASTER CYLINDER INSPECTION CHART

Part	Inspect For:	Corrective Action:
Master cylinder body.	Scratches, scores, pits, other damage affecting sealing or sliding action of piston seals in master cylinder bore. Damaged threads. Cracks, structural damage. By-pass and compensating holes to be open.	Polish light damage smooth with crocus cloth; replace piece, if damage does not clean up quickly.  Clean up or replace. Replace. Open and clean passage.
Spring retainers.	Check for cracks, deformation.	Replace.
Master cylinder primary and secondary pistons.	Nicks, scratches, corrosion on finished O.D. surfaces. Small holes in end open. Try fit in master cylinder to be free with slight play.	Do not repair; replace.  Clean. Replace piston cylinder or both if tight or sloppy.
Master cylinder reservoir diaphragm.	Hardness, holes, punch marks, cuts or abrasion.	Replace.

5. Remove the primary seal, primary seal protector and secondary seals from the secondary piston.

## CLEANING AND INSPECTION

Use clean brake fluid to thoroughly clean all reusable brake parts. Immerse in the cleaning fluid and brush metal parts with hair brush to remove foreign matter. Blow out all passages, orifices and valve holes. Air dry and place cleaned parts on clean paper or lint free clean cloth. If slight rust is found inside either the front or rear half housing assemblies, polish clean with crocus cloth or fine emery paper, washing clean afterwards.

**CAUTION:** *Be sure to keep parts clean until reassembly. Re-wash at re-assembly if there is any occasion to doubt cleanliness—such as parts dropped or left exposed for eight hours or longer.*

IF there is any suspicion of contamination or any evidence of corrosion, completely flush the vehicle hydraulic brake system. Failure to clean the hydraulic brake system can result in early repetition of trouble. Use of gasoline, kerosene, anti-freeze, alcohol or any other cleaner, with even a trace of mineral oil, will damage rubber parts.

### Rubber Parts

Wipe fluid from the rubber parts and carefully inspect each rubber part for cuts, nicks or other damage. These parts are the key to the control of fluid or air flow. If the unit is in for overhaul, or if there is any question as to the serviceability of rubber parts, **REPLACE** them! Inspect in accordance with the following table. The table is organized by power brake unit groups. Badly damaged items, or those which would take extensive work or time to repair, should be replaced. In case of doubt, install new parts. Do not rely on the brake unit being overhauled at an early or proper interval. New parts will provide more satisfactory service, even if the brake unit is allowed to go beyond the desired overhaul period.

## ASSEMBLY (FIGURE 32)

If the brass tube inserts were removed, place the master cylinder in a vise so that the outlet holes are up. Position the new brass tube inserts in the outlet holes, making sure they are not cocked. The recommended method of seating these inserts is to thread a spare brake line tube nut into each outlet hole and turn the nuts down until the insert bottoms.

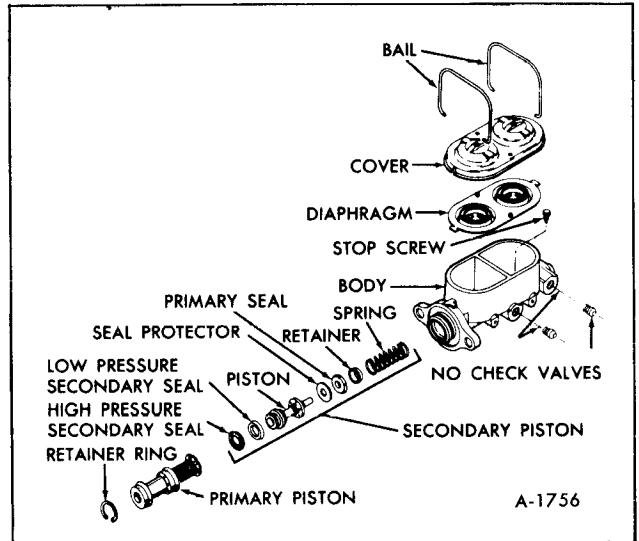

Figure 32—Master Cylinder (Exploded View)

(Remove the tube nut and check the outlet hole for loose brass burrs, which might have been turned up when the insert was pressed into position.)

Each vehicle application of these cylinders is designed to produce the correct displacement of fluid from both the front and rear chambers under normal, failed and partially failed conditions. Delco Moraine dual cylinders are designed so that this variable displacement requirement is controlled within each bore size by the dimensions A and C on the secondary piston.

Because the pistons vary in length, it is necessary to mark them with identification rings. It is imperative that exact replacements be made when servicing the master cylinders.

With all of the variables to be found in master cylinders, which look similar externally, it is important that the complete assemblies be properly identified. For this purpose a two-letter metal stamp will be found on the end of each master cylinder. This two-letter stamp indicates the displacement capabilities of a particular master cylinder. It is, therefore, mandatory that when master cylinders are replaced, they are replaced with cylinders bearing the same two-letter stamp.

1. Place new secondary seals in the two grooves in the flat end of the secondary piston assembly. The seal which is nearest the flat end will have its lips facing toward this flat end. The seal in the second groove should have its lips facing toward the end of the secondary piston which contains the small compensating holes.

2. Assemble a new primary seal and primary seal protector over the end of the secondary piston oppo-

site the secondary seals, so that the flat side of the seal seats against the flange of the piston which contains the small compensating holes.

3. In order to insure correct assembly of the primary piston assembly, a complete primary piston assembly is included in the repair kits.

4. Coat the bore of the master cylinder with clean brake fluid. Coat the primary and secondary seals on the secondary piston with clean brake fluid. Insert the secondary piston spring retainer into the secondary piston spring. Place the retainer and spring down over the end of the secondary piston so that the retainer locates inside the lips of the primary seal.

5. Holding the master cylinder with the open end of the bore up or down, push the secondary piston into the bore so that the spring will seat in against the closed end of the bore. Use a small wooden rod to push the secondary piston to seat.

6. Place the master cylinder in a vise with the open end of the bore up. Coat the primary and secondary seals on the primary piston with clean brake fluid. Push the primary piston, secondary piston stop first, into the bore of the master cylinder. Hold the piston down and snap the lock ring into position in the small groove in the I.D. of the bore.

7. Continue to hold the primary piston down. This will also move the secondary piston forward and will insure that the secondary piston will be forward far enough to clear the stop screw hole, which is in the bottom of the front fluid reservoir. The stop screw is now positioned in its hole and tightened to a torque of 25-40 inch-pounds.

8. Install a new reservoir diaphragm in the reservoir cover and install the cover on the master cylinder. Assemble the bail wires into position to retain the reservoir cover.

## WHEEL CYLINDER OVERHAUL

### DISASSEMBLY

1. Pull boots from cylinder ends and discard boots.
2. Remove and discard pistons and cups.

### CLEANING AND INSPECTION

1. Inspect cylinder bore for scoring or corrosion. It is best to replace a corroded cylinder.

**NOTE:** Staining is not to be confused with corrosion. Corrosion can be identified as pits or excessive roughness.

2. Polish any discolored or stained area with crocus cloth by revolving cylinder on cloth supported by a finger. Do not slide cloth in a lengthwise manner under pressure.

Do not use any other form of abrasive or abrasive cloth.

3. Rinse cylinder in Declene or equivalent.

4. Shake excessive rinsing fluid from cylinder. Do not use a rag to dry cylinder, as lint from the rag cannot be kept from cylinder bore surfaces.

### ASSEMBLY

1. Lubricate cylinder bore and counterbore with clean brake fluid and insert spring expander assembly.

2. Install new cups. (Be sure cups are lint and dirt free). Do not lubricate cups prior to assembly.

3. Install new pistons in the "as Received" condition—do not lubricate pistons with brake fluid.

4. Press new boots into cylinder counterbores by hand. Do not lubricate boots prior to assembly.

## CALIPER OVERHAUL

### DISASSEMBLY

Before beginning disassembly, thoroughly clean the exterior of the caliper using clean Declene or equivalent. Place the caliper on a clean work surface.

Remove the brake hose from the caliper, discarding the copper gasket. Check the hose for worn spots, cracks or other signs of deterioration. Discard the hose, if damaged, replace with a new hose at reassembly. Drain brake fluid from the caliper.

**WARNING: DO NOT PLACE THE FINGERS IN FRONT OF THE PISTON IN AN ATTEMPT TO CATCH OR PROTECT IT WHEN APPLYING COMPRESSED AIR. THIS COULD RESULT IN SERIOUS INJURY.**

Remove the piston by directing compressed air into the caliper inlet hole. As shown in Figure 33.

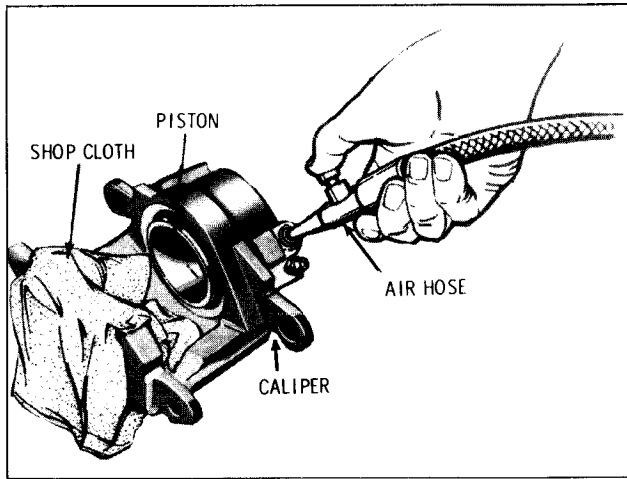

Figure 33—Removing Piston

**CAUTION:** Use just enough air pressure to ease the piston out of the bore. If the piston is blown out—even with padding provided—it may become damaged.

Use a screwdriver to pry the boot out of the caliper. Extend the screwdriver across the caliper bore, under the boot, and pry up. Be careful not to scratch the caliper bore (figure 34).

Use a piece of wood or plastic to remove the piston seal from its groove in the caliper bore. **DO NOT USE A METAL TOOL OF ANY TYPE FOR THIS OPERATION.**

Remove the bleeder valve from the caliper.

## CLEANING AND INSPECTION

The boot, piston seal, rubber bushings and

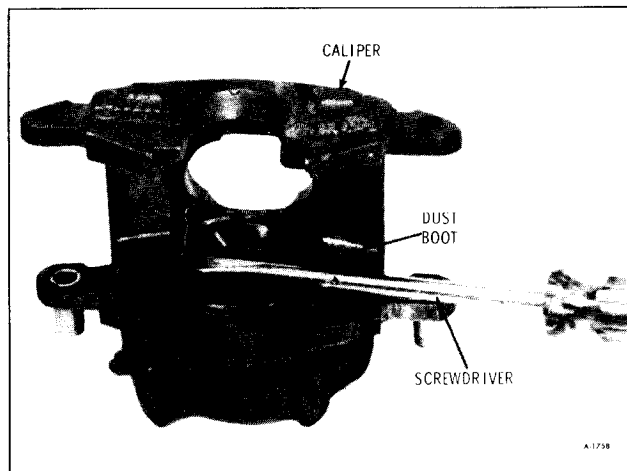

Figure 34—Removing Boot from Caliper

sleeves are to be replaced each time the caliper is overhauled.

Clean all other parts in clean Declene or equivalent. Use dry, filtered compressed air to dry parts and blow out all passages in the caliper and bleeder valve.

**WARNING: THE USE OF LUBRICATED SHOP AIR WILL LEAVE A FILM OF MINERAL OIL ON THE METAL PARTS. THIS MAY DAMAGE RUBBER PARTS WHEN THEY COME IN CONTACT AFTER REASSEMBLY.**

Check the mounting bolts for corrosion, breaks in the plating or other damage. Do not use abrasives in an attempt to clean the bolts. If bolts are damaged, replace them.

Carefully examine the piston OD for scoring, nicks, corrosion and worn or damaged chrome plating. If any surface defects are detected, replace the piston.

**NOTE:** The piston OD is the primary sealing surface in the caliper assembly. It is manufactured and plated to close tolerances. Refinishing by any means or the use of any abrasive is not acceptable.

Check the bore in the caliper for the same defects as the piston. The piston bore is not plated and stains or minor corrosion can be polished with crocus cloth. Do not use emery cloth or any other form of abrasive. Thoroughly clean the caliper after the use of crocus cloth. If the bore can not be cleaned up in this manner, replace the caliper.

## ASSEMBLY

Lubricate the bore in the caliper and the new piston seal with clean brake fluid. Position the seal in the caliper bore groove. Lubricate the piston with clean brake fluid and assemble a new boot into the groove in the piston so that the fold faces the open end of the piston. Insert the piston into the caliper bore, using care not to unseat the seal and force down to the bottom in the bore. This will require a force of 50 to 100 pounds.

Position the OD of the boot in the caliper counterbore and seat with Tool J-22904 (figure 35).

Check the boot installation to make sure that the retaining ring molded into the boot is not bent and that the boot is installed fully—below the caliper face—and evenly all around. Otherwise dirt or moisture may enter the bore and cause damage or corrosion.



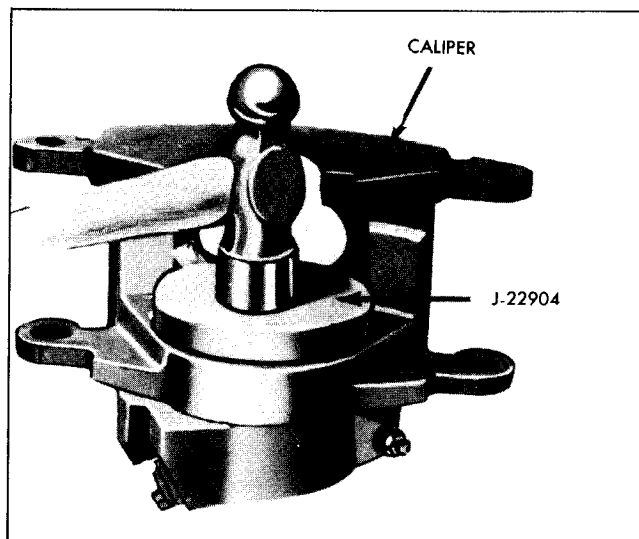

Figure 35-Boot Installation

Install the brake hose in the caliper inlet using a **NEW** copper gasket.

## POWER BRAKE BOOSTER OVERHAUL

### DISASSEMBLY

**CAUTION:** Care must be used in handling the diaphragm of power piston assembly. Guard diaphragm against grease, oil, foreign matter and nicks or cuts.

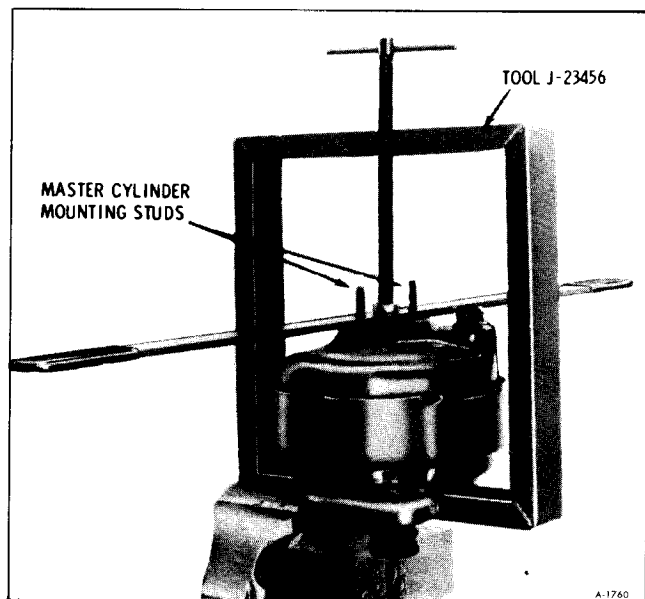

Figure 36-Separating Halves

1. Scribe front and rear housing.
  2. Remove master cylinder attaching nuts and remove master cylinder from front housing.
  3. Remove front housing seal and master cylinder piston push rod.
  4. Install Tandem Diaphragm Separating Tool J-23456 as shown in Figure 36.
  5. With cylinder clamped slightly, rotate bar counterclockwise and unlock shells.
  6. Back off on hold down sufficiently to remove front shell, return spring retainer plate and piston rod retainer.
  7. Remove assembly from tool and remove tool from vise.
  8. Remove the dust boot retainer and boot from the rear housing and push rod. Remove the felt silencer from inside the boot.
  9. Remove the power piston assembly from the rear shell and remove the primary power piston bearing from the center opening of the rear shell.
  10. Lift the bead on the outside diameter of the secondary diaphragm and remove the diaphragm support ring. (figure 37)
  11. Mount Piston Unlocking Tool, J-23101, in a vise with wide jaws up. Position the secondary power piston so that the two radial slots in the piston fit over the jaws of the tool. (figure 38)
  12. Fold back primary diaphragm from the outside diameter of the primary support plate. Grip the edge of the support plate and rotate counterclockwise to unscrew the primary power piston from the secondary power piston. (figure 39)
- NOTE:** It is possible that the primary support plate will unlock from the primary piston before the primary piston unscrews from the secondary piston. If this happens, continue to turn the primary support plate counterclockwise. Tabs ("stops") on the primary support plate will temporarily lock the primary support plate to the primary power piston and permit continued counterclockwise rotation to unscrew the primary power piston from the secondary power piston.
13. Remove the housing divider from the secondary power piston. Remove the secondary power piston bearing from the housing divider.

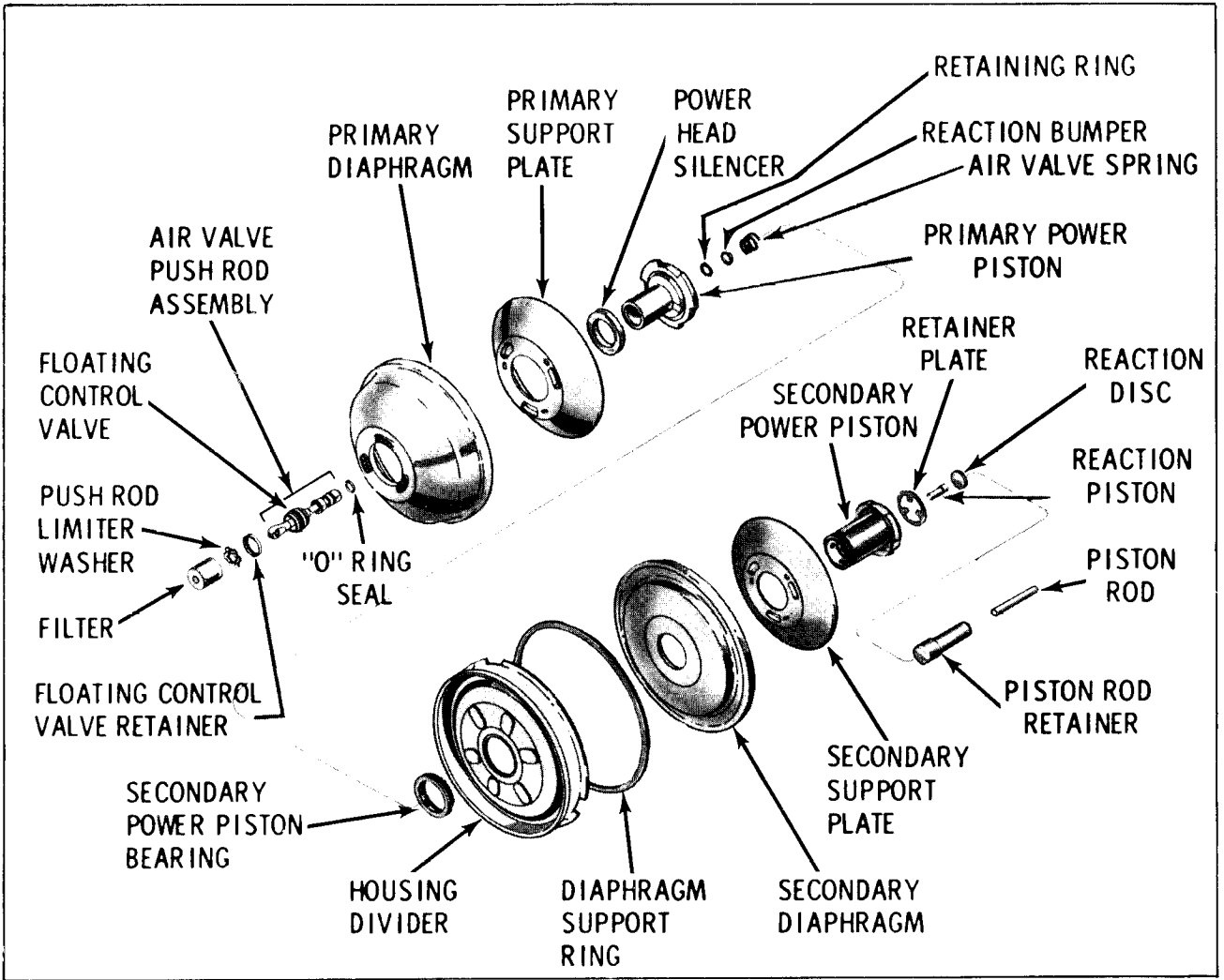

Figure 37—Exploded View of Power Piston

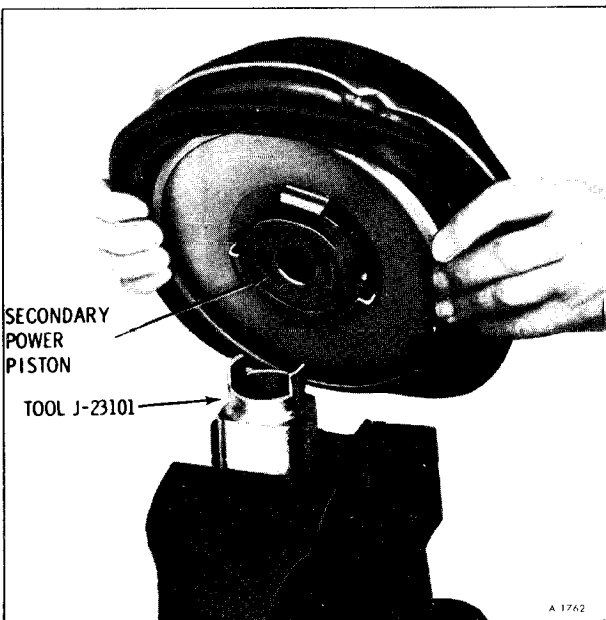

Figure 38—Positioning Secondary Power Piston



Figure 39—Unlocking Power Piston

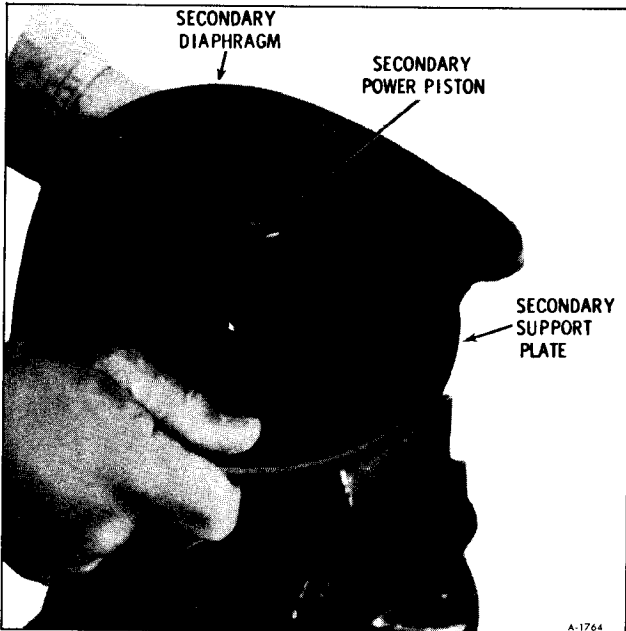

Figure 40—Removing Secondary Diaphragm

14. The secondary power piston should still be positioned on Tool J-23101. Fold back secondary diaphragm from O.D. of secondary support plate. Grip the edges of the support plate and rotate clockwise to unlock the secondary support plate from the secondary power piston. (figure 40).

15. Remove the secondary diaphragm from the secondary support plate.

16. Remove the reaction piston and reaction disc from the center of the secondary power piston by

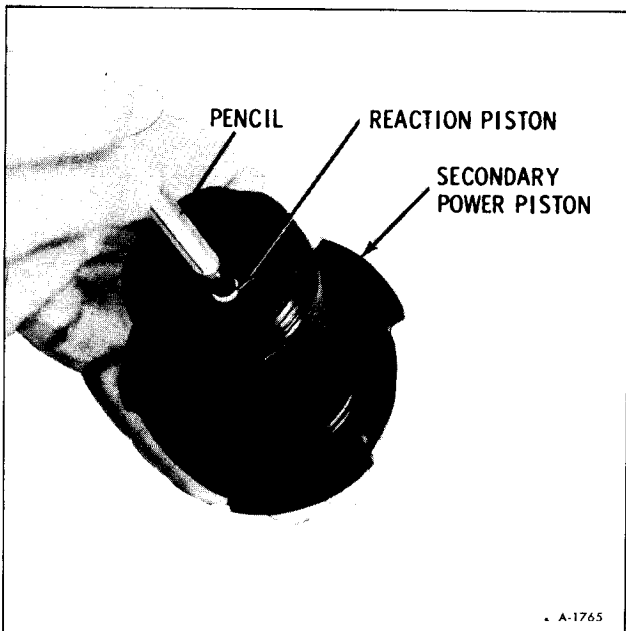

Figure 41—Removing Reaction Piston

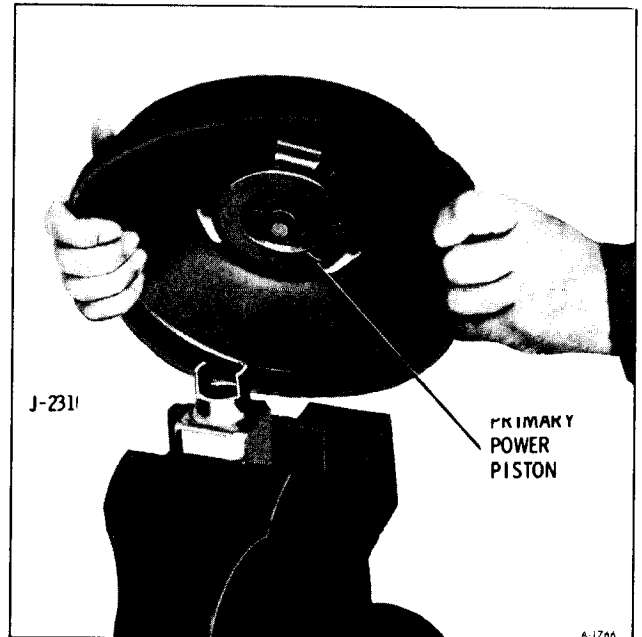

Figure 42—Positioning Primary Power Piston

pushing down on the end of the reaction piston with a small object, such as a pencil, wooden dowel or metal rod. (figure 41)

17. Remove the air valve spring from the end of the air valve.

18. Mount Tool J-23101 in a vise with small jaws up. Position the primary power piston so that the two radial slots in the piston fit over the jaws of the tool. (figure 42)

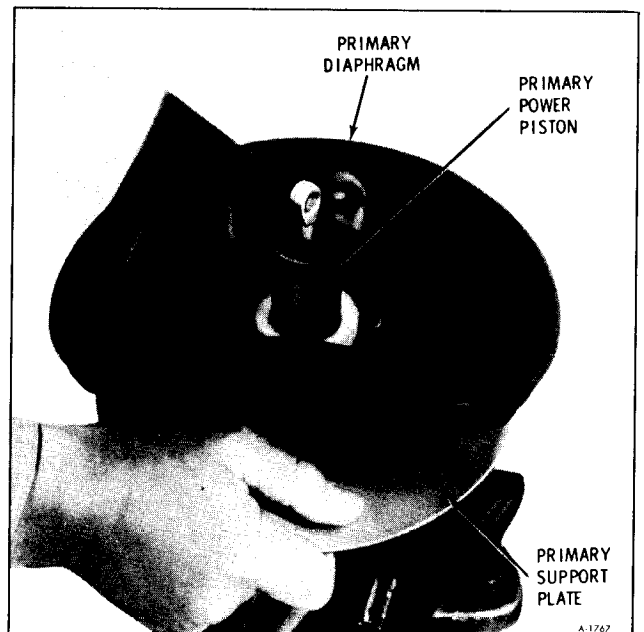

Figure 43—Removing Primary Diaphragm

19. Fold back primary diaphragm from the support plate. Grip the edge of the support plate and rotate in a counterclockwise direction to unlock the primary support plate from the primary power piston. (figure 43)

20. Remove the primary diaphragm from the primary support plate.

21. Remove the air filter and push rod limiter washer from the tubular section of the primary power piston.

22. Remove the power head silencer from the neck of the power piston tube.

23. Remove the rubber reaction bumper from the end of the air valve.

24. Remove the snap ring from the air valve. (figure 44)

25. Remove the air valve-push rod assembly from the tube end of the primary power piston by pulling on the primary power piston. (figure 45)

26. Removal of the air valve push rod assembly will disassemble the floating control valve retainer.

27. Remove the "O" ring seal from the air valve.

28. The air valve push rod assembly will be serviced using a complete assembly, since the floating control valve cannot be removed over the eye end of the push rod.

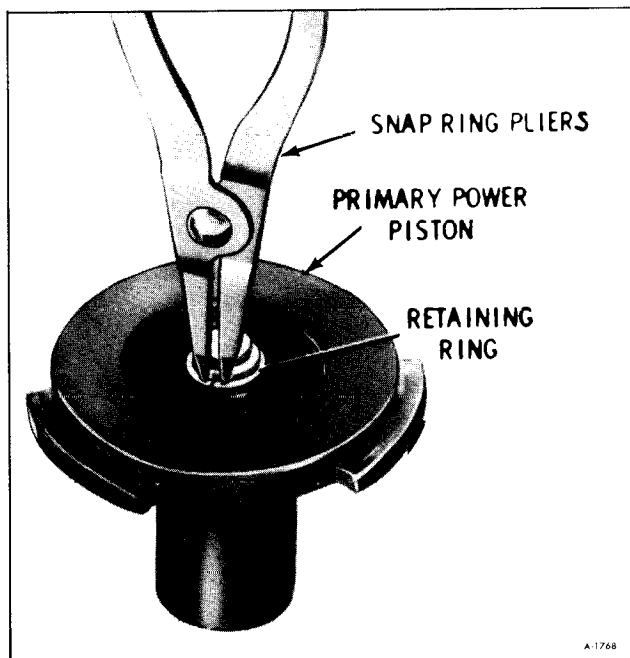

Figure 44—Removing Snap Ring from Air Valve

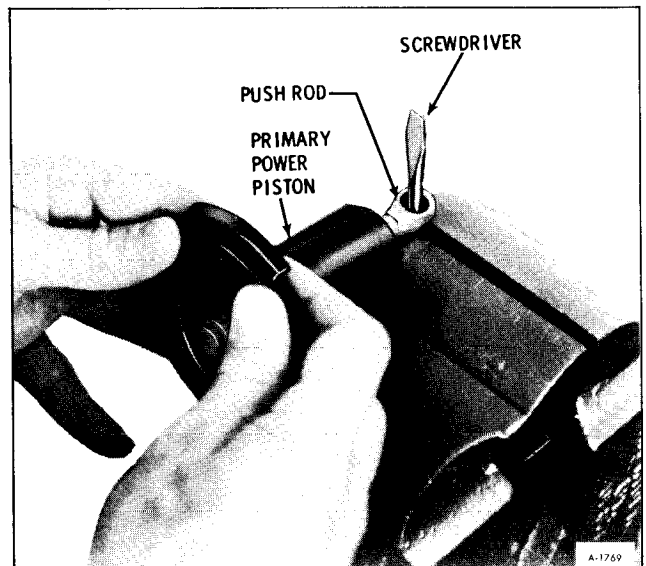

Figure 45—Removing Air Valve Push Rod Assembly

## CLEANING AND INSPECTION

**CAUTION:** *If there is any suspicion of contamination or any evidence of corrosion, completely flush the hydraulic brake system. Failure to clean hydraulic brake system can result in early repetition of trouble. Do not use gasoline, kerosene, anti-freeze alcohol or any other cleaner with even a trace of mineral oil.*

After disassembly, immerse all metal parts in metal cleaner. Plastic parts, as well as the rubber power diaphragms, should be cleaned in Declene or equivalent. Care should be taken to avoid chipping or damaging plastic parts in handling. After parts have been thoroughly cleaned, those parts which come in contact with hydraulic brake fluid (that is, all master cylinder parts and the power section push rod) should be thoroughly washed in Declene or equivalent before assembly. Use air to blow out dirt and cleaning solvent from recesses and internal passages. **DISCARD ALL RUBBER PARTS EXCEPT THE POWER DIAPHRAGMS.**

## ASSEMBLY

**NOTE:** During assembly, when a lubricant is specified, use either the lubricant furnished with the repair kit or Seal Lubricant No. 1050169 or equivalent.

1. Lubricate the "O" ring seal, Figure 37 and place on the air valve.

2. Wipe a thin film of lubricant on the large and small O.D. of the floating control valve.

3. If the floating control valve needs replacement, replace the complete air valve push rod assembly.

4. Place the air valve end of the air valve push rod assembly into the tube of the primary power piston. Manually press the air valve push rod assembly so that the floating control valve bottoms on the tube section of the primary power piston.

5. Place lip of retainer on the O.D. of Tool J-23175. (figure 46) Manually press the retainer until seated in the primary power piston tube. (figure 47)

6. Place the push rod limiter washer over the push rod and position on the floating control valve.

7. Install filter element over the push rod eye and press into the primary power piston tube.

8. Using snap ring pliers, place the snap ring into the groove in the air valve.

9. Install the rubber reaction bumper on the air valve.

**NOTE:** Tolerances of component parts affecting output of the tandem power brake are very critical. To maintain correct power brake output, the

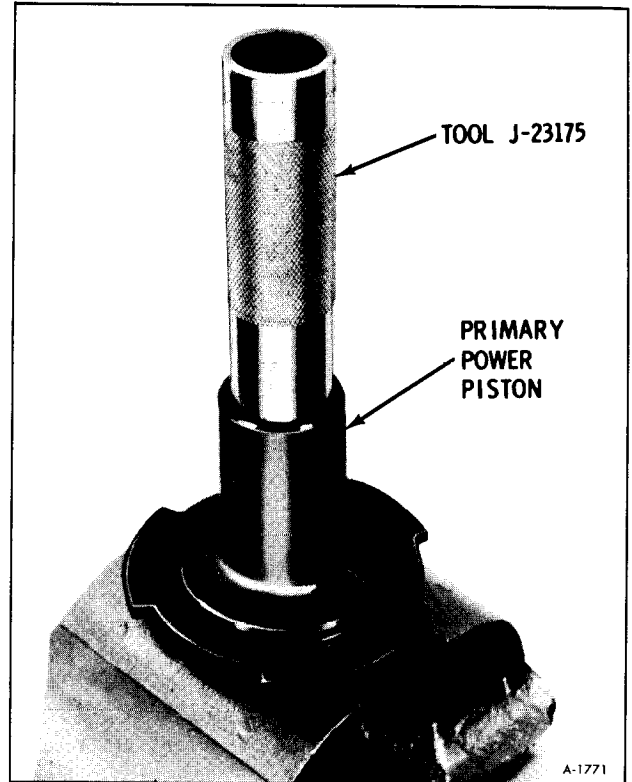

Figure 47—Retainer Ring Seated

power piston assembly is serviced as an assembly which includes a pre-selected REACTION PISTON, PRIMARY POWER PISTON, and SECONDARY POWER PISTON. NO gauging operation is required when power piston service package is used.

10. Assemble the primary diaphragm to the primary support plate from the side of the support plate opposite the locking tangs. Press the raised flange on the I.D. of the diaphragm through the center hole of the support plate. Be sure that the edge of the support plate center hole fits into the groove in the raised flange of the diaphragm. Lubricate the diaphragm I.D. and the raised surface of the flange (that fits into a groove in the primary power piston) with a light coat of lubricant.

11. Mount Tool J-23101, in a vise, small jaws up. Position the primary power piston so that the two radial slots in the piston fit over the jaws of the tool. (figure 42)

12. Fold the primary diaphragm away from the O.D. of the primary support plate.

13. Holding the edges of the support plate, with the locking tangs down, place the primary support plate and diaphragm assembly over the tube of the primary power piston. The flange on the I.D. of the

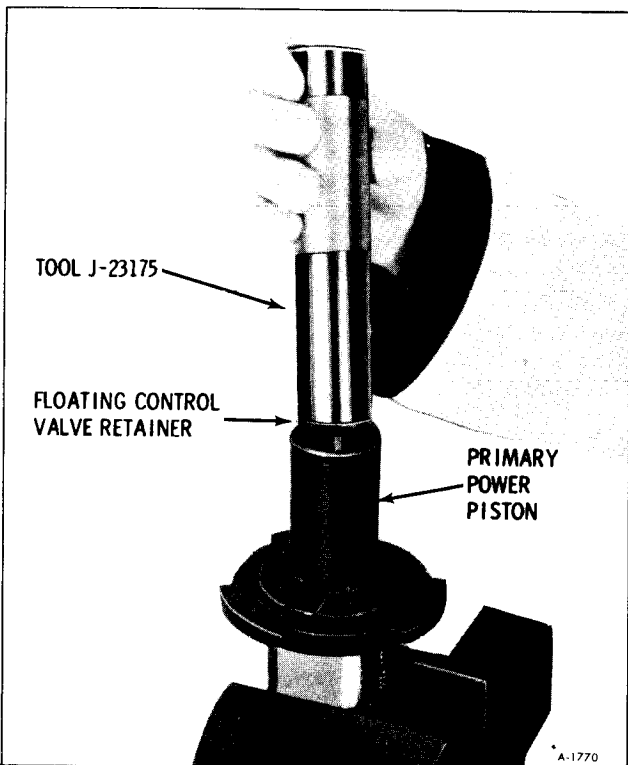

Figure 46—Installing Retainer Ring

primary diaphragm will fit into a groove in the primary power piston.

14. Grip the edges of the primary support plate, press down, and rotate clockwise until the tabs on the primary power piston contact the stops on the support plate. (figure 43)

15. Place the power head silencer on the tube of the primary power piston so that the holes at the base of the tube are covered.

16. Apply a very light film of lubricant to the O.D. of the primary power piston tube.

17. Remove the primary piston assembly from Tool J-23101.

18. Assemble the secondary diaphragm to the secondary support plate from the side of the support plate opposite the locking tangs. Press the raised flange on the I.D. of the diaphragm through the center hole of the support plate. Be sure that the edge of the support plate center hole fits into the groove in the raised flange of the diaphragm. Apply a thin coat of lubricant to the I.D. of the secondary diaphragm and the raised surface of the flange (that fits into a groove in the secondary power piston.)

19. Mount Tool J-23101 in a vise with large jaws up. Position the secondary power piston so that the radial slots in the piston fit over the jaws of the tool. (figure 38) Apply a light coat of lubricant to the tube of the secondary power piston.

20. Fold the secondary diaphragm away from the O.D. of the secondary support plate.

21. Holding the edges of the support plate, with the locking tangs down, place the secondary diaphragm and support plate assembly over the tube of the secondary power piston. The flange on the I.D. of the secondary diaphragm will fit into the groove in the secondary piston.

22. Grip the edges of the secondary support plate, press down, and rotate counterclockwise until the tabs on the secondary power piston contact the stops on the support plate. (figure 40) Fold the secondary diaphragm back into position on the secondary support plate. Leave the secondary power piston assembly on Tool J-23101 in the vise.

23. Apply a light coat of lubricant to the bead on the O.D. of the secondary diaphragm. This will facilitate assembly of front and rear housings.

24. Place the secondary diaphragm support ring on the secondary power piston assembly so that it rests on the edge of the diaphragm.

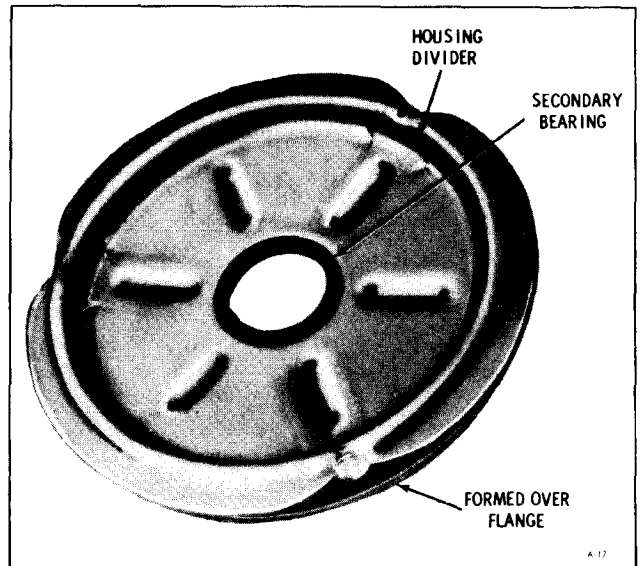

Figure 48—Installing Secondary Bearing

25. Hold the housing divider so that the formed lip (that holds the primary diaphragm) of the divider faces down. Place the secondary bearing in the I.D. of the divider so that the extended lip of the bearing faces up. (figure 48)

26. Lubricate the I.D. of the secondary bearing.

27. Position Tool J-23188, on the threaded end of the secondary power piston. (figure 49)

28. Hold the housing divider with the formed lip (that holds the primary diaphragm) facing up. Press the divider down over the tool and onto the secondary power piston tube where it will rest against the diaphragm support ring. Remove Tool J-23188 from secondary power piston. Do not remove the secondary power piston subassembly from Tool J-23101.

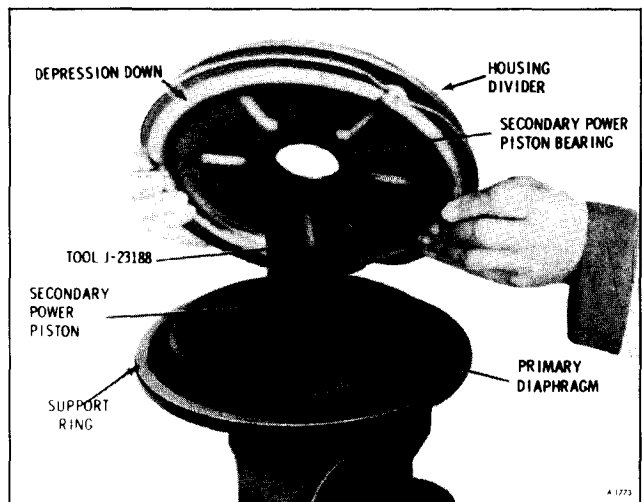

Figure 49—Installing Housing Divider

29. Pick up the primary power assembly and position the small end of the air valve return spring on the air valve so that it contacts the air valve retaining ring.

30. Fold the primary diaphragm away from the O.D. of the primary support plate.

31. Position the primary power piston on the tubular portion of the secondary power piston, making sure that the air valve return spring seats down over the raised center section of the secondary piston.

32. Grip the edge of the primary support plate, press down, and start the threads on the secondary power piston into the threaded portion of the primary power piston by rotating in a clockwise direction. (figure 39)

33. Continue to tighten the primary power piston until it is securely attached to the secondary power piston.

34. Fold the primary diaphragm back into position on the primary support plate and pull the diaphragm O.D. over the formed lip of the housing divider. Check that the bead on the diaphragm is seated evenly around the complete circumference.

35. Wipe a thin film of lubricant on the O.D. of the piston rod retainer. Insert the master cylinder piston rod retainer into the cavity in the secondary power piston so that the flat end bottoms against the rubber reaction disc in the bottom of the cavity.

36. Place the primary power piston bearing in rear housing center hole so that the formed flange of the housing center hole fits into the groove of the

primary power piston bearing. The thin lip of the bearing will protrude to the outside of the housing. (figure 50)

37. Coat the I.D. of the primary power piston bearing with a thin film of lubricant.

38. Assemble the power piston assembly to the rear shell by pressing the tube of the primary power piston through the rear housing bearing. Press down until the housing divider seats in the rear shell and the primary power piston bottoms against the shell.

39. Mount Tool J-23456 in vise and position rear shell in tool.

40. Place piston rod retainer plate on the end of the power piston and install power piston return spring.

41. Lower front shell over rear shell and position bar on front shell with bearing.

42. Tighten down on front shell and fit the tangs in the appropriate slots on the rear shell.

43. Rotate the bar clockwise into the locked position and remove power head from Tool J-23456.

44. Place the filter in the power head boot. Stretch the boot over the push rod and over the flange of the rear housing and install boot retainer.

45. Place the power head assembly in a vise with the front shell facing up. Insert the master cylinder piston rod, flat end first, into the piston rod retainer.

46. Press down on the master cylinder piston rod to be sure it is properly seated.

**NOTE:** To assure that no vacuum is in the power head while gauging, front housing seal must not be installed at this time.

47. Place gauge J-23337 over the piston rod in a position which will allow the gauge to be moved to the left or right without contacting the studs. (figure 51)

48. Position gauge over piston rod. The adjustment is correct if the lower step contacts the piston rod and the upper step clears the piston rod.

49. If the push rod is not within specifications and the push rod does not have an adjusting screw, a new service adjustable push rod must be installed and adjusted to specification. If the push rod being checked has an adjusting screw, adjust the push rod to specification.

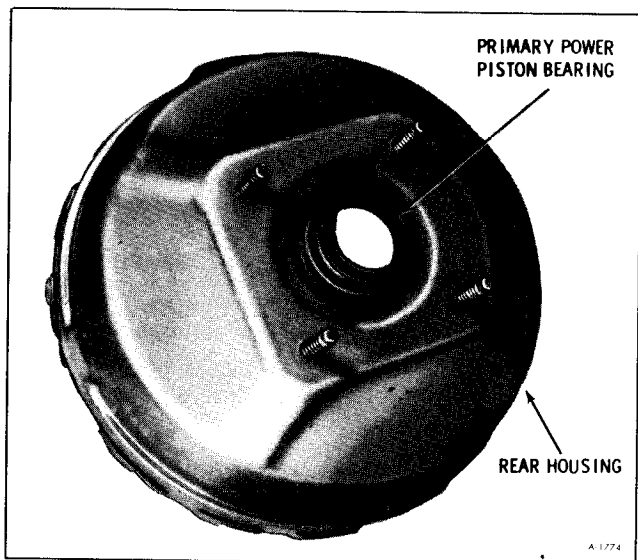

Figure 50—Installing Primary Power Piston Bearing

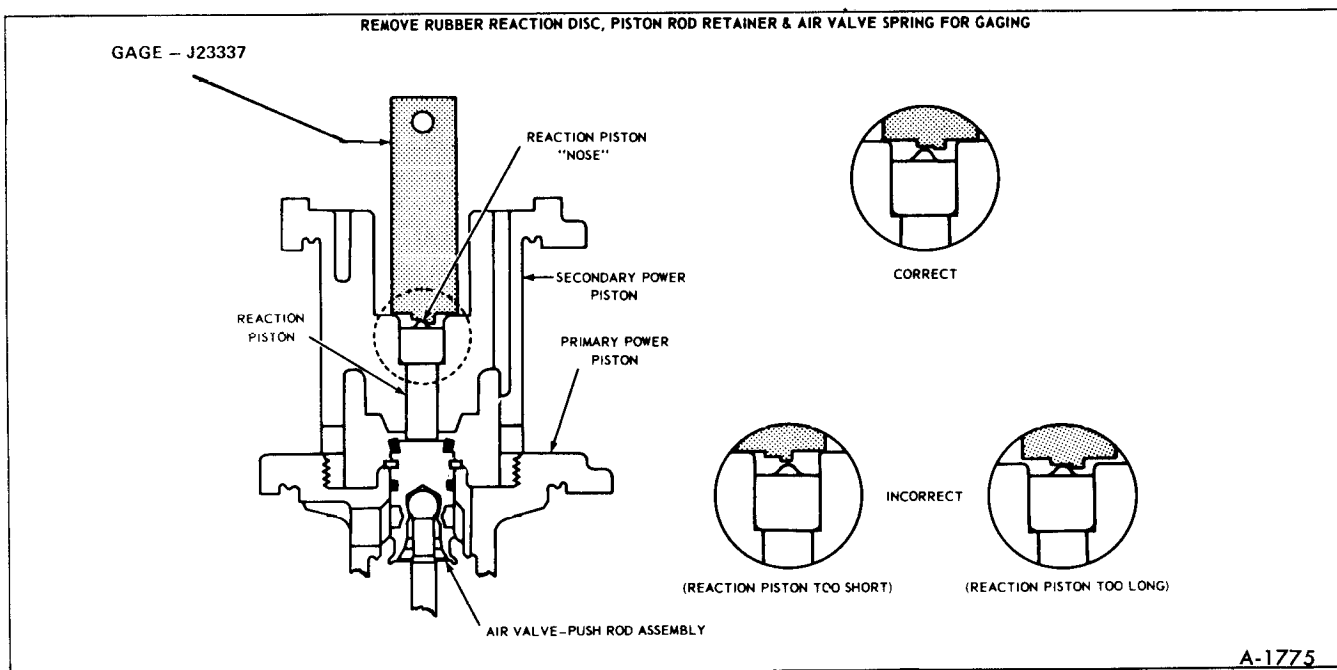

Figure 51-Gauging Piston Rod

50. Wipe a thin film of lubricant on the I.D. of the front housing seal and position seal in the depression in the housing.

51. Position the master cylinder assembly on the front housing. Install the locknuts on the studs and torque to 28 ft. lbs.

52. Install power unit into Motor Home.

## TESTING OF POWER BRAKE UNIT

1. Road test brakes by making a brake application at about 20 mph to determine if vehicle stops evenly and quickly. If pedal has a spongy feel when applying brakes, air may be present in hydraulic system. Bleed system as described in BLEEDING SYSTEM.

2. With engine stopped and transmission in neutral, apply brakes several times to deplete all vacuum

reserve in system. Depress brake pedal, hold light-foot pressure on pedal and start engine. If vacuum system is operating, pedal will tend to fall away under foot pressure and less pressure will be required to hold pedal in applied position. If no action is felt, vacuum system is not functioning.

3. Stop engine. Again deplete all vacuum reserve in system. Depress brake pedal and hold foot pressure on pedal. If pedal gradually falls away under foot pressure, hydraulic system is leaking internally or externally.

4. If brake pedal travels to within one inch of toeboard, brake shoes are not adjusting or require relining.

5. Start engine with brakes off and transmission in neutral. Run engine to medium speed and turn off ignition. Immediately close throttle. This builds up vacuum. Wait no less than 90 seconds, then try brake action. If not vacuum-assisted for two or more applications, vacuum check is faulty or there is a leak in vacuum system.

# MAJOR COMPONENT INSPECTION

## COMBINATION VALVE

No attempt should be made to disassemble or repair either valve. If any failure should occur, the complete valve should be replaced.

## REAR BRAKE SHOES AND BACKING PLATE

1. Inspect linings for wear. If linings are worn



nearly flush with rivets new linings should be installed.

2. Check wheel cylinder for leakage by removing the link. If leak exists, remove wheel cylinder for service or replacement.

3. Clean inner surfaces of brake backing plates and all shoe contacting points.

4. Clean exposed portions of parking brake cables.

5. Disassemble the adjusting screw assembly. Clean and inspect as follows:

a. Check thrust washer and mating surfaces for burrs or excessive wear.

b. Inspect teeth on sprocket for wear.

c. Remove all foreign material from adjusting screw and nut. Nut must rotate freely on threads.

6. Check the foot of the adjuster lever for wear. Replace if necessary.

7. Check the override pivot for wear or deformed parts.

8. Check brake drum inner diameter for build-up rust and dirt. Remove build-up so that drums can be installed over pre-adjusted linings. Check drum for cracks and an out-of-round condition.

## DISC BRAKE SHOE AND LINING

### LINING INSPECTION

Inspect the brake linings any time that the wheels are removed (tire rotation, etc.). Check both ends of the outboard shoe by looking in at each end of the caliper. These are the points at which the highest rate of wear normally occurs. However, at the same time, check the lining thickness on the inboard shoe to make sure that it has not worn prematurely. Look down through the inspection hole in the top of the caliper to view the inboard shoe. Whenever the thickness of any lining is worn to the approximate thickness of the metal shoe, all shoe and lining assemblies should be replaced.

Front disc brakes have a wear indicator that makes a noise when the linings wear to a degree where replacement is required. (figure 52) The spring clip is in an integral part of the inboard shoe and lining. When the lining is worn the clip contacts the rotor and produces a warning noise.

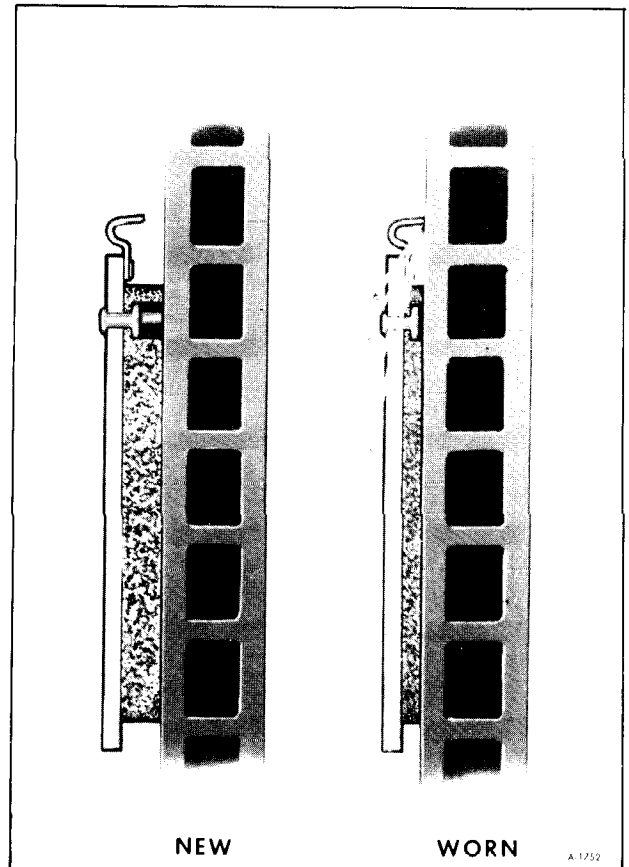

Figure 52—Wear Indicators

Check flatness of brake pads. Place inboard and outboard pad surfaces together and check for gap between pad surfaces. If more than .005" gap is measured at middle of pad (midway between attaching lugs), pad must not be used. This applies to new or used brake pads.

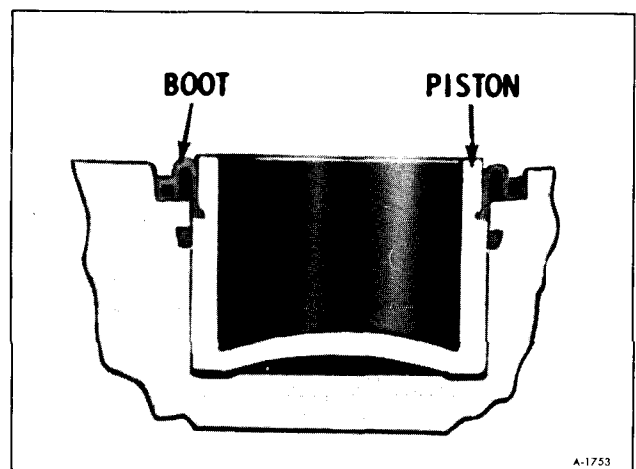

Figure 53—Boot Installation

## CLEANING AND INSPECTION

1. Thoroughly clean the holes and the bushing grooves in the caliper ears. Wipe all dirt from the mounting bolts. Do not use abrasives on the bolts since this will damage the plating. If the bolts are corroded, or damaged, they should be replaced.

2. Examine the inside of the caliper for evidence of fluid leakage. If leakage is noted, the caliper should be overhauled. Wipe the inside of the caliper clean, including the exterior of the dust boot. Check the boot for cuts, cracks or other damage. Make sure that the boot is properly engaged in the groove in the piston and also in the caliper counter-bore. (figure 53)

**CAUTION:** *Do not use compressed air to clean the inside of the caliper since this may cause the dust boot to become unseated.*

## DISC INSPECTION

Light scoring .010-.020 inch deep, of the disc braking surface will normally occur during brake application, turning is not required unless they are severely scored. It is not necessary to remove all score marks when turning. Precision equipment must be used when turning discs and the following specifications must be carefully observed. **DO NOT** reduce total thickness of the braking surface any more than the turning dimension of 1.185". If too much is removed, even maximum pedal travel will not apply the brakes if pads are worn.

Disc runout can be checked by clamping a dial indicator to the caliper or plain arm so that the stylus touches the disc about an inch from its outer edge. Rotate disc and check indicator reading. If the lateral runout exceeds specifications the disc should be replaced or refinished.

After turning, brake surface thickness must not vary more than .0005". Lateral runout must not exceed specifications. Surface finish must be non-directional and smoothness maintained at 30-50 micro inches.

If only one disc requires turning, the disc on the opposite wheel should be sanded with 60 or 80 grit emery cloth to give braking surfaces a non-directional surface.

A discard dimension 1.170" is stamped on all production installed brake disc's (See figure 54). This is the allowable wear dimension and **NOT** the allowable turning dimension. There must be .015" left for wear after turning disc's.

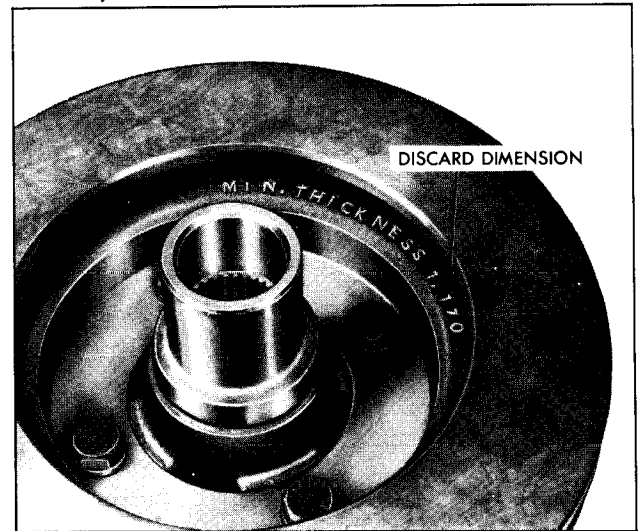

Figure 54-Discard Dimension (Disc)

## BRAKE DRUMS

### INSPECTING AND RECONDITIONING BRAKE DRUMS

Whenever brake drums are removed, they should be thoroughly cleaned and inspected for cracks, scores, deep grooves and out-of-round. Any of these conditions must be corrected since they can impair the efficiency of brake operation and cause premature failure of other parts.

### CRACKED, SCORED, OR GROOVED DRUM

**NOTE:** A cracked drum is unsafe for further service and must be replaced. Do not attempt to weld a cracked drum.

Smooth up any slight scores by polishing with fine emery cloth. Heavy or extensive scoring will cause excessive brake lining wear, and it will probably be necessary to rebores in order to true up the braking surface.

If the brake linings are slightly worn and the drum is grooved, the drum should be turned just enough to remove grooves and the ridges in the lining should be lightly removed with a lining grinder.

If brake linings are to be replaced, a grooved drum should be turned for use with oversize linings. A grooved drum, if used with new lining, will not only wear the lining, but will make it difficult, if not impossible to obtain efficient brake performance.

## OUT-OF-ROUND OR TAPERED DRUM

An out-of-round drum makes accurate brake shoe adjustment impossible and is likely to cause excessive wear of other parts of brake mechanism due to its eccentric action. An out-of-round drum can also cause severe and irregular tire tread wear as well as a pulsating brake pedal. When the braking surface of a brake drum exceeds the factory specification limits in taper (and/or) being out-of-round, the drum should be turned to true up the braking surface.

Drum out-of-round can be measured with a dial indicator and extension rod. Out-of-round measurements exceeding .006", (total indicator reading) require turning or replacement of drum.

## TURNING DRUMS

If irregularities in the braking surface of the drum cannot be removed with emery cloth or out-of-round exceeds .006" (total indicator reading), the drum can be turned to .060" greater than the original inside diameter. If a drum has smooth score marks .010" to .020", it is serviceable without turning.

If a drum is turned to a diameter less than .030" standard replacement linings may be used. Over .030" oversize linings should be used.

A discard dimension 11.090" (figure 55) is stamped on all production installed brake drums.



Figure 55-Discard Dimension (Drum)

This is the allowable wear dimension and NOT the allowable turning dimension. There must be .030" left for wear after turning drums. The maximum turning diameter is 11.060".

## REPLACING DRUMS

Whenever new drums are to be installed, the braking surface of the drum must be thoroughly cleaned with lacquer thinner to remove the rust-proof coating.

# COMPONENT INSTALLATION

## BRAKE DRUM INSTALLATION

1. Install hub and drum assembly (figure 10).
2. Install flat washer and castellated nut on hub while rotating hub and drum assembly.
3. Tighten castellated nut to 25-30 lbs. ft. torque to position bearings. (Be sure drum is rotating while tightening nut).
4. Back off nut 1/2 turn.
5. Retighten nut finger tight, secure if possible with cotter pin.
6. If unable to secure at finger tight, back off nut to first securing position.

7. Check end play between hub and spindle it should be .001 to .005 inch.

## REAR BRAKE SHOE INSTALLATION

1. Lubricate the adjusting screw threads, thrust washer mating surfaces and backing plate ledges with brake lubricant, such as Part No. 1050110 or equivalent.
2. Assemble the adjusting screw.
3. Attach the primary to secondary shoe spring to the shoes and install the adjusting screw. The primary to secondary shoe spring must not contact the adjusting screw sprocket.

4. Position shoe assembly on the backing plate. Be sure wheel cylinder links are properly positioned in the shoe notches.

5. Position the upper end of the actuating link on the brake shoe guide.

6. Engage the actuating link with the override pivot. Then position the adjuster lever and return spring on the secondary shoe. Position sleeve in the hole in secondary shoe and fasten to backing plate with hold-down spring assembly and pin.

7. Install the remaining primary hold-down spring, washer and pin.

8. Install the primary and secondary brake shoe return springs.

9. Adjust brake shoes as outlined under BRAKE SHOE ADJUSTMENT.

10. Install the hub and drum assembly. Adjust wheel bearings.

11. If wheel cylinder was removed, bleed brakes.

12. Check fluid level in master cylinder. Fluid level should be no more than 1/4" below the reservoir opening at rear.

## DISC BRAKE SHOE INSTALLATION

1. Using Silicone Lube, No. 1050018, or equivalent, lubricate new sleeves, on all surfaces. Lubricate new rubber bushings, bushing grooves and the small ends of bushings in all four caliper ears. Install rubber bushings in all four caliper ears.

**CAUTION:** *It is essential that the new sleeves and rubber bushings be used and that lubrication instructions be followed in order to insure the proper functioning of the sliding caliper design.*

2. Install the sleeves. Position the sleeves so that the end toward the shoe and lining assemblies is flush with the machined surface of the ear.

3. Install the shoe support spring by placing the single tang end of the spring over the notch in the center of the edge of the shoe. Then press the two tangs at the spring end of the inboard shoe spring over the bottom edge of the shoe so that they engage the shoe securely.

4. Position the new inboard shoe and lining as-

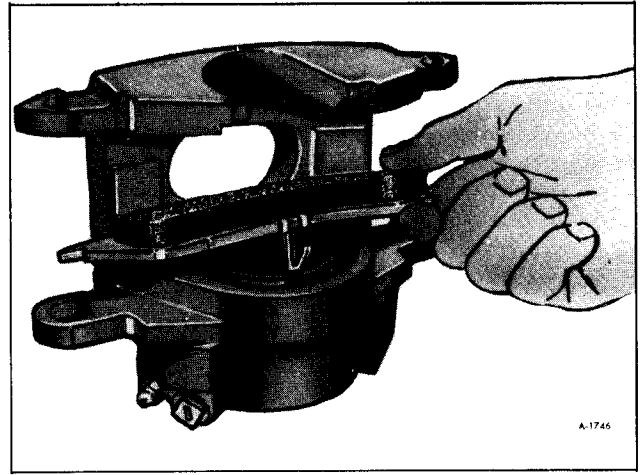

Figure 56—Installing Inboard Shoe

sembly (with spring attached) in the caliper so that the ear end of the shoe and lining is down and the bottom end up at an angle with the spring resting on the piston I.D. (figure 56). Press down on both ends of the shoe until the shoe is in a flat position, resting on the piston. The spring end of the inboard shoe support spring should be resting on the I.D. of the piston.

**NOTE:** If the shoe support spring is not installed correctly, a low or no brake pedal could occur.

5. Insert new outboard shoe into caliper making sure no clearance exists between shoe and caliper face. (figure 57)

6. Position the caliper over the disc, aligning the holes in the caliper ears with the holes in the mounting bracket.

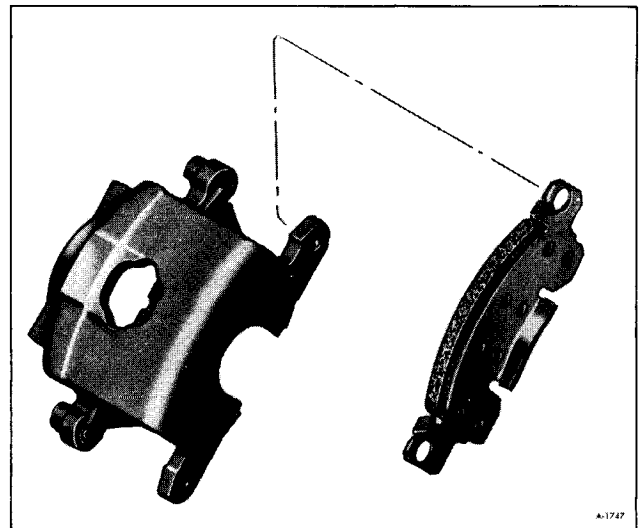

Figure 57—Installing Outboard Shoe

Make sure that the brake hose is not twisted or kinked. Start the bolts through the sleeves in the inboard caliper ears and through the mounting bracket making sure that the ends of the bolts pass under the retaining ears on the inboard shoe. Push bolts on through to engage the holes in the outboard shoes and the outboard caliper ears at the same time threading the bolts into the mounting brackets. Torque the bolts to 35 ft. lbs.

7. Fill master cylinder reservoir with new brake fluid No. 5464831 or equivalent to within 1/4" of top of reservoir.

8. Depress brake pedal to seat linings against rotor.

9. Clinch upper ears of outboard shoe by positioning channel lock pliers with one jaw on top of upper ear and one jaw in notch on bottom of shoe, opposite upper ear.

10. After clinching, ears must be flat against caliper housing with no radial clearance.

11. If radial clearance exists, repeat clinching procedure.

12. Replace the shoe and linings on the other front wheel disc brake in the same manner. Relining is to be done in full sets only.

**NOTE:** Right and left calipers must not be interchanged. When installed properly, the bleed screw will be on top.

13. When completed, reinstall the wheel and tire assemblies. Lower the Motor Home to the floor. Add brake fluid to the master cylinder reservoirs to bring the level up to within 1/4" of the top.

**NOTE:** Do not move vehicle until firm brake pedal is obtained.

Whenever the front wheel disc brakes are relined, the rear drum brakes should be checked also.

## COMBINATION VALVE INSTALLATION (FIGURE 13)

1. Install valve on mounting bracket.
2. Connect wiring to switch terminal on valve.
3. Connect all brake lines to valve.

4. Bleed entire brake system. Refer to "BLEEDING BRAKE SYSTEM" as described earlier in this section.

## MASTER CYLINDER INSTALLATION

1. Position master cylinder on power cylinder so push-rod enters cavity in master cylinder piston.
2. Install two attaching nuts (figure 15).
3. Connect two hydraulic lines to master cylinder and tighten fittings securely. (figure 14).
4. Fill master cylinder reservoir with brake fluid, No. 5464831, and bleed all wheel cylinders as outlined under "BLEEDING BRAKE SYSTEM".

## DISC INSTALLATION

1. Install four hub to disc attaching bolts, and torque to 35 ft. lbs. (figure 58). See caution on page 1 of "FRONT SUSPENSION" section 3A.
2. Position retainer over hub.
3. Lubricate seal lips with Special Seal Lubricant No. 1050169 or equivalent then position seal over hub with metal end toward retainer.
4. Install bearing as shown in Figure 59.

Lubricate O.D. of bearing with E.P. chassis grease.



Figure 58—Hub to Disc Bolts

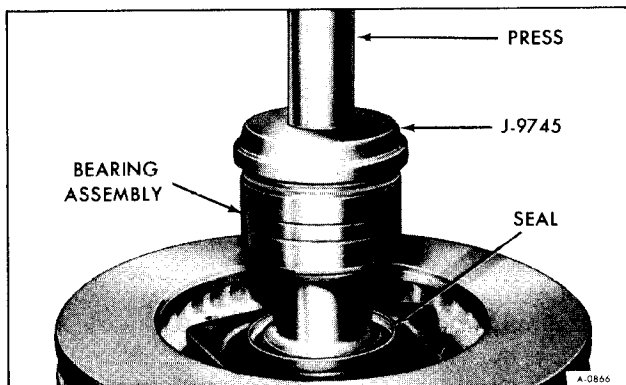

Figure 59—Installing Bearing

The outer race of the bearing is a snug fit into knuckle. Light tapping on the hubs outer surface not the disc will aid assembly.

Care must be used when installing hub assembly over drive axle splines so that splines are in correct alignment.

5. Install three bolts attaching bearing retainer to knuckle. Torque to 35 ft. lbs.

6. Install drive axle washer and nut. Torque nut to 150 ft. lbs. If necessary to align cotter pin slot, tighten nut and install NEW cotter pin and crimp. Torque not to exceed 280 ft. lbs.

**NOTE:** Do not back off nut to install cotter pin.

## POWER BRAKE BOOSTER INSTALLATION

1. Position booster assembly on firewall and install four retaining bolts. (figure 22).

2. Connect vacuum line to booster assembly.

3. Install master cylinder mounting bracket from booster assembly to firewall.

4. Install master cylinder, refer to "Master Cylinder Installation".

5. Install clevis pin retaining brake pedal to brake booster assembly clevis. Secure with cotter pin refer to Figure 21.

6. Install power level control panel and secure with four screws.

## PARKING BRAKE LEVER INSTALLATION

1. Position lever on toe board.

2. Position cable in its retaining bracket and install pin.

3. Install parking brake switch.

4. Install two nuts and bolts holding cable retaining bracket to lever base (figure 24).

5. Install four nuts and bolts holding lever to toe board (figure 23).

## FRONT PARKING BRAKE CABLE INSTALLATION

1. Position cable through toe board.

2. Install retainer and retainer pin on end of cable through lever.

3. Install clip to retain cable at shift relay bracket.

4. Install end of cable in front equalizer with front cable on top of intermediate cable. Install adjusting nut and lock nut (figure 25).

5. Adjust parking brake as described earlier in this section.

## INTERMEDIATE PARKING BRAKE CABLE INSTALLATION

1. Position cable through frame rails.

2. Place cable in guides at frame rails (figure 27).

3. Place cable in guide at crossmember (figure 26).

4. Install cable at front equalizer with intermediate cable under front cable. Install adjusting nut and lock nut (figure 25).

5. Install intermediate equalizers including adjusting and lock nuts (figure 5).

6. Adjust parking brake as described earlier in this section.

## REAR PARKING BRAKE CABLE INSTALLATION

1. Install the rear cable through the backing plate and connect the ball to the lever. Make sure the locking fingers are fully expanded on the backing plate (figure 29).

2. Install hubs and drums as described under "Brake Drum Installation".

3. Feed ends of cables through brackets on frame rails and install clips (figure 28).

4. Connect ends of cables and install intermediate equalizer, with intermediate cable on top of rear cable (figure 25).

5. Adjust parking brake as described earlier in this section.

## BRAKE PEDAL INSTALLATION

1. Properly position brake pedal assembly.

2. Install two nuts, one at each end of pedal assembly (figure 30 & 31).

3. Tighten left hand brake lever pivot bracket.

4. Insert clevis pin into clevis and brake pedal assembly. Secure with a cotter pin (figure 21).

5. Install brake light switch.

6. Install power level valve mounting panel and secure with four screws.

## BRAKE LINE TUBING INSTALLATION

**WARNING: DOUBLE FLARING TOOL MUST BE USED AS SINGLE FLARING TOOLS CANNOT PRODUCE A FLARE STRONG ENOUGH TO HOLD THE NECESSARY PRESSURE.**

Hydraulic brake tubing is a double layer annealed steel terne plate tubing which resists corro-

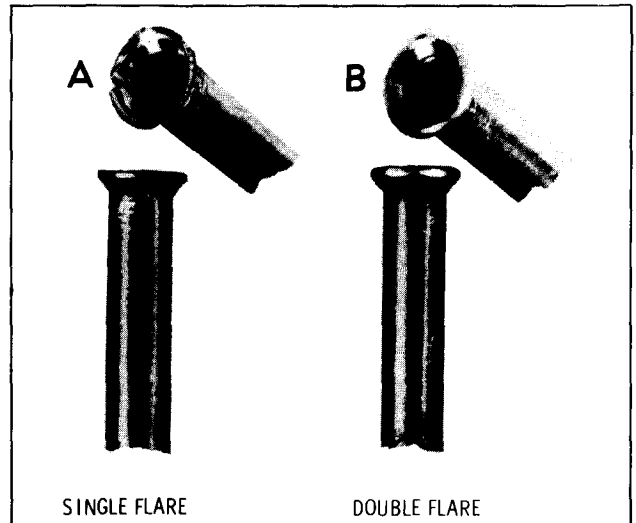

Figure 60—Single and Double Lap Flare

sion and has the physical strength to stand up under the high pressures which are developed when applying the brakes. In making up hydraulic brake pipes, it is important that the proper flaring tool be used to flare the ends of the tubing for the compression couplings. Unless the tubing is properly flared, the connections will leak and the brakes will become ineffective.

**WARNING: NEVER USE COPPER TUBING BECAUSE COPPER IS SUBJECT TO FATIGUE CRACKING WHICH WOULD RESULT IN BRAKE FAILURE.**

Steel tubing must be double-lap flared at the ends in order to produce a strong leakproof joint.

Special tools are available from tool companies for making double-lap flares. Do not attempt to flare steel tubing without proper tools. Figure 60 shows a single and a double-lap flare, note the split in the single-lap flare. The double-lap is well formed and unbroken due to the reinforcement of the double wall.

Refer to Figure 61 for brake line routing and attachment.

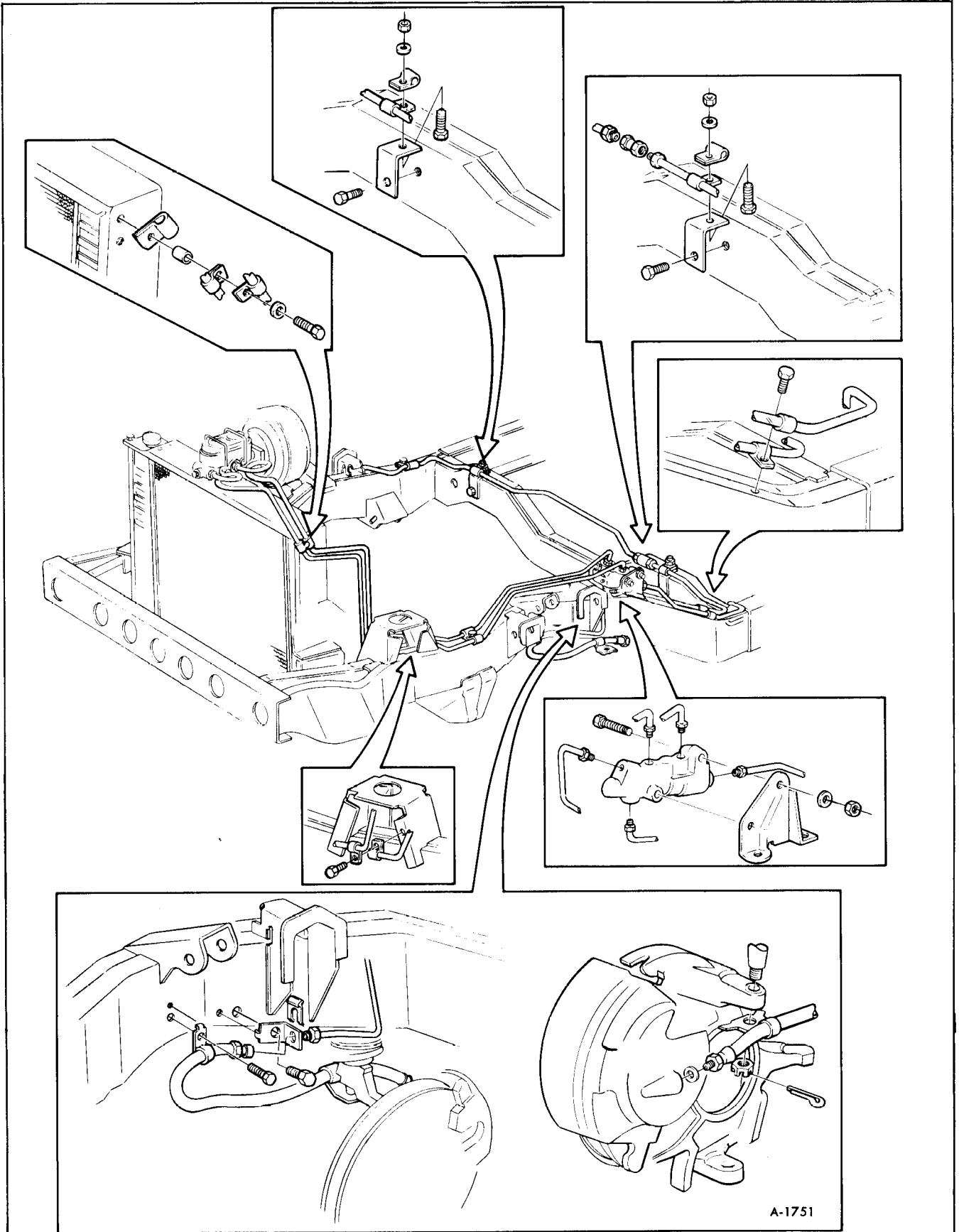

Figure 61-Brake Line Routing



## SPECIFICATIONS

### Drums

#### Inside Diameter

Original .....	11"
Maximum .....	11.090"
Max. Out-of-Round .....	(Total Indicator Reading .006")

### Discs

Outside Diameter .....	11"
Lateral Runout .....	.005"
Thickness Variation .....	.0005"
Disc Thickness	
Original .....	1.200"
Minimum .....	1.170"

### Linings

#### Drums

Length-Primary .....	8.90"
Length-Secondary .....	11.60"
Width .....	2.0"
Thickness-Primary .....	.200"
Thickness-Secondary .....	.290"

#### Discs

Length .....	5.4"
Thickness-Inner .....	.43"
Thickness-Outer .....	.40"

Fluid Type ..... Delco Supreme 11 or DOT-3 fluid or equivalent

## TORQUE SPECIFICATIONS

### Combination Valve to Mounting Bracket

Nut Torque ..... 8-12 ft. lbs.

### Combination Valve Mounting Bracket to Frame Rail

Screw Torque ..... 72 in. lb. min. (Fully Driven not Stripped)

### Power Cylinder to Firewall

Nut Torque ..... 12-16 ft. lbs.

### Master Cylinder Bracket to Firewall

Bolt Torque ..... 15-20 ft. lbs.

### Brake Lever Pivot Bolt

Bolt Torque ..... 30-35 ft. lbs.

### Brake Lever Pivot Bracket to Firewall

Nut Torque ..... 25-30 ft. lbs.

### Power Cylinder to Master Cylinder

Nut Torque ..... 28 ft. lbs.

Hub to Drum Bolt Torque ..... 70-85 ft. lbs.

Drum to Spindle Nut Torque ..... 25-30 ft. lbs.

J 22904	Dust Boot Seal Installer
J 23101	Diaphragm Plate Separator
J 23175	Control Valve Installer
J 23188	Secondary Power Piston Bearing Seal Protector
J 23337	Reaction Piston Gauge
J 23456	Brake Booster Separating Fixture
J 23518	Tandem Brake Bleeder Adapter
J 23709	Combination Valve-Metering Valve Actuator



# SECTION 6A

## ENGINE

Contents of this section are listed below:

SUBJECT	PAGE NO.
General Information .....	6A- 2
Description .....	6A- 2
Engine Maintenance and Storage .....	6A- 2
Engine Lubrication System .....	6A- 2
Engine Diagnosis .....	6A- 3
In-Vehicle Service Operations .....	6A-26
Oil Pressure Test .....	6A-26
Oil Filter .....	6A-26
Front Engine Mounts .....	6A-27
Rear Engine Mounts .....	6A-27
Intake Manifold .....	6A-29
L.H. Exhaust Manifold .....	6A-32
R.H. Exhaust Manifold .....	6A-33
Valve Cover .....	6A-33
Rocker Arm Assemblies .....	6A-33
Valve Lifters .....	6A-34
Cylinder Head and Gasket .....	6A-37
Valves and Springs with Head Removed .....	6A-38
Valve Guide Bores .....	6A-39
Replacing Valve Spring (Head on Engine) .....	6A-40
Oil Pan .....	6A-41
Oil Pump .....	6A-42
Connecting Rod and Piston Assembly .....	6A-43
Rod Bearings .....	6A-43
Piston .....	6A-45
Checking Cylinder Bore .....	6A-46
Rings .....	6A-46
Rod and Piston Assembly .....	6A-47
Piston Pins .....	6A-48
Crankshaft Pulley .....	6A-48
Belt Tension .....	6A-48
Harmonic Balancer .....	6A-48
Front Cover Oil Seal .....	6A-49
Front Cover .....	6A-50
Timing Chain and Gears .....	6A-51
Engine Replacement .....	6A-53
Out of Vehicle Service Operations .....	6A-57
Camshaft .....	6A-57
Camshaft Bearings .....	6A-57
Crankshaft .....	6A-57
Main Bearings .....	6A-59
Main Bearing Replacement .....	6A-60
Rear Main Bearing Upper Oil Seal .....	6A-61
Rear Main Bearing Lower Oil Seal .....	6A-62
Engine Specifications .....	6A-63
Torque Specifications .....	6A-65
Special Tools .....	6A-66

# GENERAL INFORMATION

## DESCRIPTION

This section of manual provides instructions for servicing the various items and tuning the engine. To adequately accomplish a satisfactory tune-up, reliable test equipment in the hands of trained personnel is necessary.

A definite, systematic maintenance program is required to assure satisfactory economical performance of engine. Included in maintenance program must be the servicing of related units and systems as well as regular servicing of engine.

## ENGINE MAINTENANCE AND STORAGE

Refer to SECTION O at the beginning of this manual for recommendations pertaining to engine servicing intervals. Winterization and storage are also covered in SECTION 24A.

## ENGINE LUBRICATION SYSTEM (FIGURE 1)

The engine oil pan forms a reservoir for engine oil to provide lubrication and also hydraulic fluid to operate the valve lifters. Oil pressure for lubrication is furnished by a gear type oil pump that is bolted to the rear main bearing cap and driven by the camshaft gear through a hexagonal drive shaft.

Oil enters the pump through a screened inlet located near the bottom rear of the oil pan. The pressurized oil from the pump passes through the engine oil cooler located in the radiator tank then to the oil filter located on the right rear side of the engine block, see Figure 2. The oil filter base has a by-pass valve which in the event of filter restriction will open at 5.3 to 6.3 psi. It then enters the right oil gallery where it is distributed to the five main bearings. The right bank valve lifters receive oil from this gallery from eight feed holes that intersect the gallery.

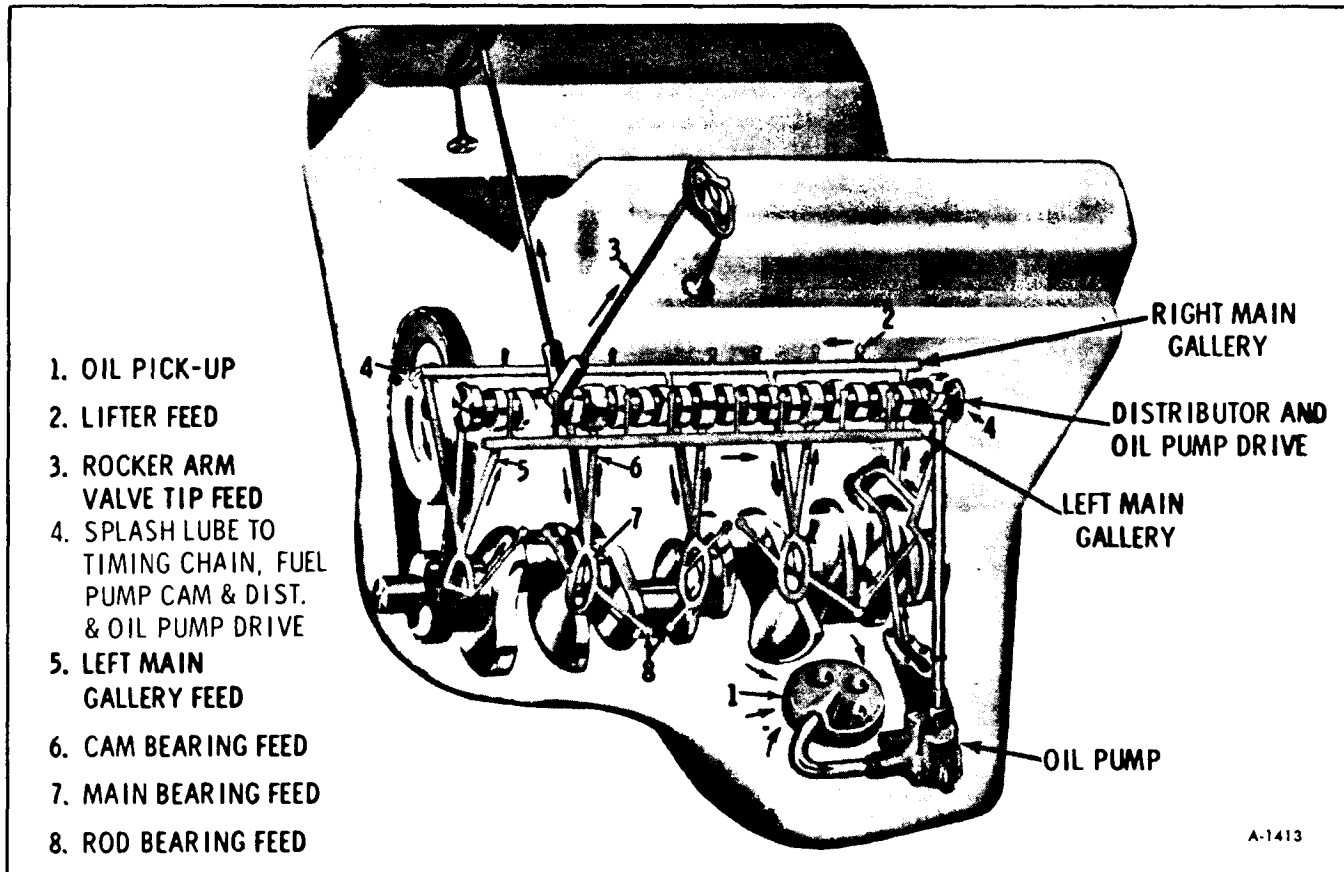

A-1413

Figure 1-Engine Lubrication

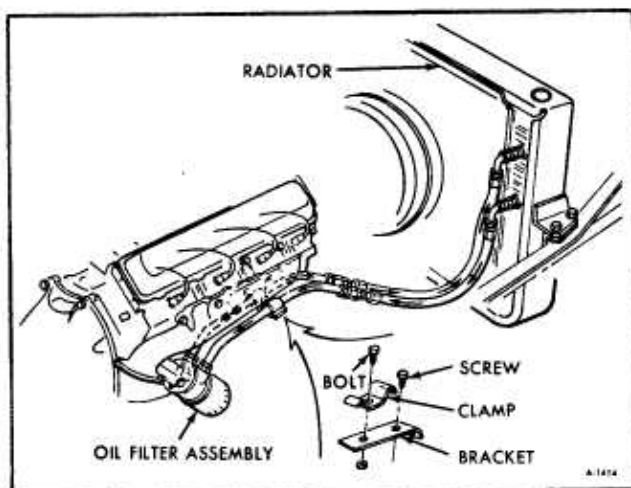

Figure 2—Oil Lines to Cooler

The five camshaft bearings are lubricated from vertical passages intersecting the main bearing oil passages. At the front main bearing a third passage connects the right main oil gallery to the left gallery which then feeds the left bank of valve lifters.

The engine oil pressure warning light switch is connected to the front of the left oil gallery. The switch is calibrated to turn on the instrument panel

warning light when engine oil pressure is too low. The switch, normally closed, is set to open at 2-6 psi. The rear oil gallery plug has a .040" orifice to help purge contaminants from the gallery.

At the front end of the right gallery, a small orifice sprays oil to lubricate the fuel pump eccentric cam and the timing chain.

The oil pump and distributor drive gear are lubricated by splash from the rear cam bearing and connecting rod bearings.

The rocker arms and valve tips are lubricated by means of oil furnished through the hydraulic lifters and hollow push-rods. A disc valve in the lifter meters oil to the push rods.

The connecting rod bearings are oiled by constant oil flow from passages drilled through the crankshaft connecting the main journals to the rod journals. A groove around each main bearing furnished oil to the drilled crankshaft passages.

Oil returns to the oil pan reservoir from the rocker arms through passages at each end of the cylinder heads. Oil from the valve lifter compartment returns through clearance holes in the lower portion of the compartment near the camshaft. The timing chain compartment drains directly into the oil pan.

## ENGINE DIAGNOSIS

**NOTE:** The numbers in parenthesis refer to **GENERAL ENGINE CHECKS** at the end of Engine Diagnosis.

SUBJECT	PAGE NO.
Engine Will Not Turn Over .....	6A- 5
Engine Turns Over Slowly But Does Not Start .....	6A- 5
Engine Turns Over at Normal Speed	
-Starts Hard When Cold.....	6A- 5
Engine Turns Over at Normal Speed	
-Starts Hard When Hot .....	6A- 6
Engine Starts - Fails to Keep Running	
or Stalls Hot or Cold.....	6A- 6
Engine Turns Over at Normal Speed	
But Does Not Start or Starts Hard .....	6A- 7
Engine Stalls at Idle - Engine Cold	
(OK When Hot).....	6A- 8
Engine Stalls at Idle - Engine Hot	
(OK When Cold).....	6A- 8
Rough Engine Idle .....	6A- 8
Engine Has Inconsistent Idle Speed (Lopes) .....	6A- 9
Engine Runs - Misses at Idle Only .....	6A- 9
Engine Runs - Misses at High Speed Only .....	6A-10

SUBJECT	PAGE NO.
Engine Runs - Misses Erratically	
At All Speeds.....	6A-10
Engine Runs - Misses Steadily at All Speeds .....	6A-11
Engine Runs - But Misses on One Cylinder .....	6A-11
Engine Runs - But Misses on Different Cylinders .....	6A-11
Engine Hesitates or Stalls During Acceleration (Spit-Back Thru Carburetor).....	6A-12
Engine Surges.....	6A-12
Lack of Power or High Speed Performance .....	6A-12
Engine Fails to Reach Operating Temperature .....	6A-13
Engine Overheats.....	6A-13
Spark Knock, Ping, or Detonation.....	6A-14
Engine Continues to Run After Ignition Is Turned Off (Dieseling) .....	6A-14
Pre-Ignition .....	6A-14
Flat Spot (Sag, Stretchiness).....	6A-15
Backfires, Popping Back, or Spitback Through Carburetor .....	6A-15
After-Burning or Muffler Explosion (Backfire).....	6A-15
Smoke (Blue, Black, White) .....	6A-16
Excessive Fuel Consumption .....	6A-16
Low Oil Pressure.....	6A-16
High Oil Pressure .....	6A-17
No Oil Pressure While Idling.....	6A-17
No Oil Pressure While Accelerating .....	6A-17
No Oil Pressure .....	6A-17
Burned, Sticking, or Broke Valves .....	6A-18
Excessive Oil Consumption.....	6A-18
Engine Noisy .....	6A-19
A. Noisy Main Bearings .....	6A-19
B. Noisy Rod Bearings .....	6A-20
C. Noisy Timing Gears .....	6A-20
D. Noisy Timing Chain.....	6A-21
E. Noisy Pistons.....	6A-21
F. Noisy Valve Mechanism.....	6A-22
G. Noisy Water Pump.....	6A-22
H. Noisy Generator .....	6A-22
I. Noisy Fan.....	6A-22
J. Noisy Fuel Pump.....	6A-23
K. Noisy Fan Belt.....	6A-23
L. Miscellaneous Noise .....	6A-23
M. Pre-Ignition or Spark Knock .....	6A-24
General Engine Checks.....	6A-24
1 Emission Control Check .....	6A-24
2 Battery Check .....	6A-24
3 Choke Check.....	6A-24
4 Flooding Check.....	6A-24
5 Carburetor Icing Check .....	6A-24
6 Spark Intensity Check .....	6A-25
7 Hard Starting Check .....	6A-25
8 Accelerating Pump Discharge Check .....	6A-25
9 Vacuum Leakage Check.....	6A-25
10 Excessive Fuel Consumption Check .....	6A-25
11 Vapor Lock Check .....	6A-26

## ENGINE WILL NOT TURN OVER

**IMPORTANT** - Delcotron generator equipped vehicles cannot be push-started when battery or starter are inoperative, because unlike a conventional generator, there is no residual magnetism in the rotor.

### GENERAL

Neutral safety switch (Automatic Transmission).

Check dipstick for congealed oil, improper viscosity, or presence of water in oil.

Remove spark plugs to check for hydrostatic lock (liquid in combustion chamber).

### ELECTRICAL

Check ignition switch and wiring.

### BATTERY

See "Battery Diagnosis Charts".

### STARTER

See "Starter Diagnosis Charts".

### MECHANICAL

Seized bearings, rings, and or pistons.

## ENGINE TURNS OVER SLOWLY BUT DOES NOT START

### GENERAL

Bad or corroded connections.

Undersized battery cable.

Poor ground.

Oil viscosity too heavy.

### MECHANICAL

Tight bearings, rings, pistons, etc.

### BATTERY

See "Battery Diagnosis Charts".

### STARTER

See "Starter Diagnosis Charts".

## ENGINE TURNS OVER AT NORMAL SPEED-STARTS HARD WHEN COLD (2) (7)

**NOTE:** Most conditions under "Does Not Start" may also cause hard starting when cold.

### IGNITION

Engine timing and dwell.

### FUEL (3) (4) (8)

If condition occurs only when ambient temperature is below 32°F., check for ice restriction in the fuel supply system. If necessary, thaw system and add anti-icing additive to the fuel. (5)

**NOTE:** In cold weather cranking speed is reduced by thickening of oil and reduction of battery efficiency.

## ENGINE TURNS OVER AT NORMAL SPEED (1)–STARTS HARD WHEN HOT (7) (11)

**NOTE:** This condition is usually caused by an over-supply of fuel due to any of the items listed under “Does Not Start” due to excessive fuel supply.

### GENERAL

Check proper starting procedure (setting choke, accelerator pumping, accelerator position, etc.).  
 Engine timing and dwell.  
 Air cleaner dirty.  
 Engine overheating. Refer to **ENGINE COOLING** in this section.

### MECHANICAL

Choke mechanism binding, sticking and/or improper adjustment. (3)

### FUEL

Vapor lock.  
 Flooding. (4)  
 Accelerator pump. (8)  
 Carburetor faulty.  
 Fuel pump faulty.  
 Fuel restricted.

### IGNITION

Check for faulty spark plugs. (6)

## ENGINE STARTS – FAILS TO KEEP RUNNING OR STALLS HOT OR COLD (7)

### GENERAL

Vapor lock. (11)  
 \*Engine overheats.  
 \*Engine runs too cool.  
 Idle speed too low.  
 Positive crankcase ventilation valve.  
 Leak in intake manifold (vacuum line faulty or disconnected). (9)  
 Exhaust crossover in intake manifold plugged.  
 Exhaust system restricted.  
 Air intake restricted.  
 Carburetor icing. (5)  
 Engine timing and dwell.

### MECHANICAL

Throttle linkage defective or improperly adjusted.  
 Valve train faulty.  
 Valve lifter or valve clearance.  
 Low compression.  
 Choke valve faulty, stuck, or binding. (3)  
 Head cracked or gasket leaking.  
 Excessive engine friction.

### FUEL

Dirt and/or water in fuel system.  
 Faulty fuel pump.  
 Float level too high. (4)  
 Idle adjustment incorrect.  
 Idle compensator valve faulty.  
 Needle valve seat faulty.  
 Mixture too rich or too lean.  
 Faulty carburetor.

### IGNITION

Spark plugs damp or dirty and/or gap incorrectly set or not installed properly.  
 Faulty coil or condenser.  
 Distributor points incorrectly set, burned, pitted or dirty.  
 Distributor advance mechanism faulty or timing improperly set.  
 Worn rotor or distributor cap loose, corroded, poor connections, or incorrect wiring.

\*Refer to **ENGINE COOLING** in this section.

## ENGINE TURNS OVER AT NORMAL SPEED BUT DOES NOT START OR STARTS HARD (7)

**NOTE:** If ignition is set too far advanced, spark may occur too early when engine is cranked. The first (and only) explosion runs the engine backward. A kickback may jam the starter or break the starter drive housing.

### IGNITION (2)

#### OPEN PRIMARY

- Burned or oxidized ignition points.
- Coil resistance unit burned out or open.
- Starting switch ignition coil resistance by-pass circuit open.
- Ignition points not closing.
- Breaker arm binding on pivot post, preventing closing of points.
- Breaker arm spring weak or broken.
- Breaker arm distorted or bent.
- Dirty ignition points.
- Primary lead connection loose at distributor or coil.
- Primary windings in coil broken.
- Open ignition switch circuit.

#### GROUNDING PRIMARY

**NOTE:** A grounded coil primary winding, a grounded ignition switch, or a grounded switch-to-coil primary lead will cause excessive current flow and will usually cause wires to burn.

- Ignition points not opening or closing due to wear or improper adjustment.
- Faulty bushing in breaker arm.
- Cracked or faulty insulator at distributor primary terminal.
- Grounded or faulty condenser.
- Distributor-to-coil lead grounded.
- Primary coil winding grounded.
- Broken or loose ignition wire or faulty switch.

### MECHANICAL

- Choke binding, sticking, or improper adjustment.
- Low or erratic compression. (Check valve train mechanism, rings, blown head gasket, etc.)

### FAULTY SECONDARY (6)

- Corroded spark plug cable terminals.
- Chafed or cracked cable insulation.
- Ignition coil weak or inoperative.
- Moisture on ignition coil, terminals, distributor cover, spark plug porcelain, or in distributor.
- Improper type of spark plugs.
- Cracked distributor cap or a burned carbon track from distributor cap center terminal to housing.
- Improper installation of spark plug cables (not correct for firing order).
- Spark plugs damaged, dirty, or wet, porcelains cracked, or gaps improperly spaced.
- Rotor contact spring bent or broken.
- Distributor rotor grounded.
- Distributor cap center terminal (inner) broken or missing.
- Broken or burned out radio suppressor in distributor cap.

### FUEL (11)

- Hot engine vapor lock.
- No fuel or insufficient fuel.
- Water and/or dirt (Fuel System).
- Excessive fuel. (4)
- Accelerator pump faulty. (8)
- Fuel pump worn or defective.
- Fuel filter dirty.
- Carburetor dirty or defective.
- Vent in fuel tank clogged or restricted.
- Carburetor mounting bolts loose.

### GENERAL

- Check proper starting procedure (setting choke, accelerator pumping, accelerator position etc.).
- Air cleaner dirty.
- Engine timing.
- Restricted exhaust.
- Poor ground or faulty wiring.



## ENGINE STALLS AT IDLE - ENGINE COLD (OK WHEN HOT)

### CARBURETOR (3) (5)

Idle too low.  
Choke high idle too low.

### MECHANICAL

Linkage improperly adjusted or damaged.

## ENGINE STALLS AT IDLE - ENGINE HOT (OK WHEN COLD)

### GENERAL

Vapor lock. (11)  
Engine overheats. (Refer to "Engine Cooling" in this section.)  
Positive crankcase ventilation valve.

### CARBURETOR (3) (4)

Idle set too low.

### MECHANICAL

Throttle linkage improperly adjusted or faulty.

## ROUGH ENGINE IDLE (1)

### GENERAL

Check all vacuum hoses for proper routing, broken or disconnected hoses and/or caps.  
Also vacuum leaks. (9)

Restricted air cleaner (Remove air cleaner with engine running and note engine rpm.).

Incorrect timing and dwell.

Positive crankcase ventilation valve dirty or stuck.

Restricted exhaust.

Cold engine (Faulty thermostat).

Fuel volatility too high or low.

### IGNITION (6)

Improper plug or plug gap.

Faulty plugs.

Improper point setting, worn or damaged.

Defective condenser and coil.

Faulty rotor or cap.

Loose wiring.

Damaged or corroded coil wiring or spark plug cables.

Moisture on wiring or in distributor cap.  
Cracked distributor cap.

### FUEL

Engine idle speed improper.

Mixture too rich or lean. (4)

Float level.

Dirt and water in fuel system.

Carburetor mounting bolts loose.

### MECHANICAL

Choke linkage, secondary throttle plates sticking, binding or damaged. (3)

Low compression.

Valve train faulty (Burnt or sticky valves, broken spring, bent push rod etc.).

Loose engine mounts or worn insulation.

Improperly torqued cylinder head.

Leaking or worn valve guides.

**NOTE:** When repairs have been made it may be necessary to re-adjust idle speed.

## ENGINE HAS INCONSISTENT IDLE SPEED (LOPES) (1)

**NOTE:** If idle speed is slow, unstable, rolling, frequent stalling, and oily engine compartment, the positive crankcase ventilation valve may be completely plugged, or the valve may be stuck in the "OPEN" position. A valve stuck in the "CLOSED" position is indicated by breather back-flow at heavy throttle and oily engine compartment. If the valve is stuck in the intermediate position it will be indicated by rough, fast idle and stalling.

### GENERAL

Restricted exhaust.  
 Vacuum leak (Intake valve stem leaking, carburetor mounting gasket leaking, carburetor throttle shaft in carburetor leaking, intake manifold or vacuum hoses leaking). (9)  
 Timing and dwell not correct.  
 Restricted air cleaner.  
 Overheated engine (Refer to "Engine Cooling" in this section). (11)  
 Blown head gasket.  
 Low compression.  
 Quality of fuel.  
 Lean idle mixture. (1)

### FUEL

Dirt and/or water in fuel system.  
 Too rich or lean mixture.  
 Filter restricted.  
 Faulty fuel pump. (4)  
 Faulty carburetor.

### MECHANICAL

Throttle shaft, accelerator pedal and/or throttle linkage sticking or binding.  
 Timing chain or gears and/or camshaft lobes worn.  
 Burned, warped, pitted, leaky or sticking valves.  
 Inoperative choke.  
 Sticking hydraulic lifter.

### IGNITION

Excessive oil or dirt on ignition system.  
 Spark plugs damp or gap incorrectly set.  
 Excessive moisture on ignition wires and caps.  
 Leaks in ignition wiring (Dirty, corroded, or faulty wiring).  
 Ignition wires making poor contact.  
 Burned, pitted, or incorrectly set contact points.  
 Faulty coil or condenser.  
 Worn distributor cam, or cracked distributor cap, radial contacts in distributor cap burned or worn.  
 Faulty spark advance mechanism.

---

## ENGINE RUNS - MISSES AT IDLE ONLY (1)

### GENERAL

Vacuum leak. (9)  
 Timing not correct.  
 Exhaust restriction.  
 Blown head gasket.  
 Low compression.  
 Fuel quality poor.  
 Air cleaner dirty.

### MECHANICAL

Leaky or incorrect valve.  
 Worn or leaky valve guide.  
 Worn timing chain, gears, sprocket or camshaft lobe.  
 Dirt in hydraulic lifter.

### IGNITION (2)

Spark plugs faulty or wrong gap.  
 Incorrect, worn, or gap incorrectly set.  
 Leaks in ignition wiring.  
 Burned, pitted, or incorrectly set contact points.  
 Faulty coil and/or condenser.  
 Faulty spark advance mechanism.  
 Defective or worn rotor and/or cap.

### FUEL (4)

Flooding in carburetor.  
 Refer to "Engine Has Inconsistent Idle Speeds" above.

## ENGINE RUNS - MISSES AT HIGH SPEED ONLY (1)

### GENERAL

Overheating (Refer to "Engine Cooling" in this section).

Detonation or pre-ignition.

Sub-standard fuel.

Faulty or dirty air cleaner.

Valve train faulty or worn.

Mild vapor lock.

Exhaust vapor lock.

Exhaust manifold clogged or restricted.

Air cleaner plugged.

### FUEL

Faulty fuel pump.

Restricted fuel filter.

Choke valve not completely closed.

Carburetor throttle lever loose on shaft.

Exhaust manifold clogged with carbon.

Exhaust manifold, muffler, or tail pipe restricted.

Intermittent delivery of fuel to carburetor so that momentarily the mixture is too weak for combustion.

### IGNITION (2)

Clean, gap, and/or replace spark plugs, as necessary.

Too hot spark plugs—change to colder type, but note that a hot plug may be due to loose installation or lack of plug gasket (if gasket is called for).

Ignition point gap much too wide or pitted.

Breaker arm binding or sticking.

Breaker arm weak.

Weak spark, coil, or condenser.

Improper ignition timing and/or dwell.

Centrifical advance not functioning properly.

Distributor cam lobe or shaft worn.

Worn rotor or damaged distributor cap.

### MECHANICAL

Incorrect valve timing.

Sticking hydraulic lifters.

Valve springs broken.

Valve springs shimmy.

Valve springs too weak to close valves promptly.

## ENGINE RUNS - MISSES ERRATICALLY AT ALL SPEEDS (1)

### GENERAL

Restricted exhaust.

Compression low.

Internal coolant leakage.

Engine overheating. (11)

Timing improperly set.

### MECHANICAL

Compression leak at head gasket or between cylinders (This can be noted when missing occurs in two adjacent cylinders).

Intermittently sticking valves.

Broken valve spring.

Valve(s) held open slightly by faulty mechanism.

### IGNITION (2)

Wrong type spark plugs.

Fouled spark plug or broken porcelain.

Faulty spark plug cables.

Low battery voltage.

Low generator voltage.

Burned or pitted ignition points.

Incorrect ignition point gap.

Faulty condenser or coil.

Weak spark or no spark in one or more cylinders.

Faulty distributor cap or rotor.

Primary circuit restricted or open intermittently.

Primary circuit detoured by short intermittently.

Secondary circuit restricted or open intermittently.

Secondary circuit detoured by short intermittently.

### FUEL

Fuel pump faulty.

Needle valve in carburetor sticking.

Improper float lever. (4)

Mixture too rich or too lean.

Passage in carburetor dirty.

**ENGINE RUNS - MISSES STEADILY AT ALL SPEEDS (1)****GENERAL**

Worn camshaft lobes.  
 Compression low.  
 Vacuum leak in intake manifold. (9)  
 Dwell and timing off.  
 Fuel poor quality.

**FUEL**

Dirty jets in carburetor.  
 Water or dirt in fuel.  
 Fuel filter plugged.  
 Fuel pump worn or diaphragm faulty.

**IGNITION (2)**

Dirty or incorrectly set points.  
 Worn, dirty, or gap set too wide in spark  
 plugs.  
 Worn distributor shaft.  
 Cam worn or burned distributor rotor.  
 Faulty coil or condenser.  
 Insufficient spring tension on points.

**MECHANICAL**

Valve train faulty.

**ENGINE RUNS - BUT MISSES ON ONE CYLINDER****GENERAL**

Compression leaking.  
 Vacuum leak at intake manifold. (9)  
 Timing and/or dwell improperly set.  
 Overheated engine. (Refer to "ENGINE  
 COOLING" in Section 6K).  
 Clogged exhaust.

**IGNITION (2)**

Defective spark plug or spark plug wire.  
 Distributor cap defective.  
 Distributor cam worn.  
 Points worn or improperly aligned.

**MECHANICAL**

Valve train defective.  
 Stuck hydraulic lifter.  
 Defective rings or piston.

**ENGINE RUNS - BUT MISSES ON DIFFERENT CYLINDERS****GENERAL**

Compression leaking.  
 Vacuum leak at intake manifold or  
 carburetor. (9)  
 Defective head gasket.  
 Dwell, timing off.  
 Poor grade fuel.  
 Carbon in engine.  
 Restricted exhaust.

**FUEL**

Fuel pump faulty.  
 Carburetor faulty.

**IGNITION (2)**

Spark plugs faulty.  
 Coil wire or distributor cap faulty.  
 Distributor cam worn.  
 Points worn or improperly set.  
 Distributor rotor faulty.

**MECHANICAL**

Faulty rings.  
 Faulty valve train.

## ENGINE HESITATES OR STALLS DURING ACCELERATION (1) (SPITBACK THROUGH CARBURETOR)

### GENERAL

Vapor lock. (11)  
 Carburetor icing. (5)  
 Restricted exhaust.  
 Compression low.  
 Intake manifold leaking (Carburetor attaching bolts loose). (9)  
 Partly blocked or dragging brake shoes (Refer to "Brake" chart).  
 Air cleaner dirty.  
 Engine timing.  
 Excessive carbon in engine.  
 Heavy oil in engine.  
 Wrong or poor grade fuel.  
 Excessive rolling resistance from low air in tires, applied brakes, wheel alignment, overloading etc.

### IGNITION (2)

Distributor faulty.  
 Wiring oily or faulty.  
 Condenser or coil faulty.  
 Faulty plugs.  
 Vacuum advance faulty.

### MECHANICAL

Accelerator pump stroke or throttle linkage improperly adjusted.  
 Stuck hydraulic lifters.  
 Intake manifold loose or leaking.  
 Carburetor mounting loose or leaking.  
 Valve train damaged or faulty.

## ENGINE SURGES (1)

### GENERAL

Exhaust system restricted or faulty.  
 Cylinder(s) not firing properly.  
 T.V.S. switch faulty. (1)  
 Vacuum leaks. (9)

### IGNITION

Check out complete ignition system. (2)  
 Faulty spark plug wires.

### FUEL (4)

Fuel pump faulty.  
 Faulty needle valve and seat.  
 Float level setting wrong.  
 Defective parts in carburetor.  
 Restrictions in fuel lines or filter.

## LACK OF POWER OR HIGH SPEED PERFORMANCE

**NOTE:** It should be noted that the altitude of operation has a decided effect on performance. An engine adjusted for normal altitudes will lack performance at high altitudes, whereas an engine when operating normally at high altitudes may have a lean carburetor adjustment and show signs of pre-ignition when operated at sea level.

### IGNITION (2)

Ignition timing or dwell incorrect.  
 Centrifugal governor advance not operating properly.  
 Vacuum advance not operating properly.  
 Ignition points burned, pitted, sticking, or bouncing. (Due to weak breaker arm spring).  
 Faulty spark plugs.  
 Faulty ignition cables.  
 Faulty ignition coil or condenser.  
 Worn or burned distributor rotor.  
 Worn distributor shaft or cam.  
 Poor ground.

### GENERAL

Pre-ignition.  
 Engine overheating. (Refer to "Engine Cooling" in this section).  
 Sub-standard fuel.  
 Overloading vehicle.  
 Excessive carbon in engine.  
 Converter defective.  
 Excessive rolling resistance (Dragging brakes, tight wheel bearings, underinflated tires).  
 Restricted exhaust.  
 Dirty air cleaner.  
 Transmission or power steering faulty.

## MECHANICAL

Choke mechanism faulty.  
Lack of engine compression.  
Incorrect valve timing.  
Inaccurate speedometer (Gives impression of lack of performance).

Valve spring weak, broken valves or valves sticking when hot.  
Valve timing incorrect.  
Worn camshaft lobes.  
Blown cylinder head gasket.  
Burned, warped or pitted valves.

---

## ENGINE FAILS TO REACH OPERATING TEMPERATURE

### GENERAL

Thermostat removed.

### COOLING

Defective thermostat (stuck open).  
Faulty temperature sending unit or dash unit.

---

## ENGINE OVERHEATS

**NOTE:** Coolant is used to cool the engine and air is used to cool the coolant. Anything which prevents the coolant air system from working properly will cause engine to overheat. (Air, oil or grease in the coolant will reduce the ability of the coolant to absorb heat from the block and to transfer heat to the coolant in the radiator.)

### GENERAL

Scale or rust deposits.  
Slipping fan belt.  
Low coolant. (Leaky system—internal or external.)  
Pre-Ignition.  
Detonation.  
Excessive friction in engine or elsewhere in power transmitting units. (Brakes dragging, etc.)  
Excessive back pressure in exhaust system.  
Overloading vehicle.  
High altitude.  
Hot climate operation.  
Insufficient oil in crankcase.

### FUEL

Carburetor mixture too lean.

### MECHANICAL

Cylinder head bolts loose.  
Warped or damaged head or block.  
Wrong head gasket.

### IGNITION

Timing late.  
Distributor advance faulty.  
Valve timing off or late.

### COOLING

Restricted flow of coolant. (Defective components—dirt, rust and scale.)  
Leaking head gasket. (Permits air in cooling system and coolant in engine.)  
Thermostat fails or wrong thermostat.  
Hoses defective.  
Exterior of radiator clogged with dirt, leaves, or insects.  
Water pump defective or loose.  
Wrong type of coolant.  
Wrong fan or hydraulic fan inoperative, or defective.  
Wrong pressure cap or faulty cap.  
Radiator fins bent or mutilated.

## SPARK KNOCK, PING, OR DETONATION

**NOTE:** A sharp metallic knock due to instantaneous abnormal combustion.

### GENERAL

Low octane fuel.  
 Too high compression.  
 Timing advanced too far.  
 Heavy carbon deposits.  
 Manifold heat control valve faulty.  
 Faulty distributor advance mechanism.  
 Breaker point dwell (or gap) too low.

### COOLING

Overheated engine. (See "Engine Cooling" in this section.)  
 Hot weather.  
 High altitude.

---

## ENGINE CONTINUES TO RUN AFTER IGNITION IS TURNED OFF (DIESELING)

**NOTE:** When the engine won't stop as the ignition is turned off, the cause is often due to red hot carbon particles resting on heavy carbon deposit in a very hot engine.

### GENERAL

Improper idle speed (too high). (1)  
 High engine temperature.  
 Poor grade fuel (octane too low).  
 Improper timing and dwell.  
 Quick shut-down of hot engine.

### IGNITION

Advanced timing.  
 Improper heat range or improperly installed spark plugs.  
 Electrical feed through ignition system (faulty switch).

### MECHANICAL

Improper valve timing.

### FUEL

Carburetor too lean.  
 Throttle plates misaligned.

---

## PRE-IGNITION

**NOTE:** Hot spot in combustion chamber ignites fuel before spark occurs. May not be noticed unless severe.

### GENERAL

Overheated engine.  
 Carbon deposits.  
 Spark plugs not tight.  
 Spark plugs with wrong heat range.  
 Timing and dwell improperly set.

### MECHANICAL

Leak at valve due to clearance, valve sticking, weak or broken spring.  
 Valve timing.

## FLAT SPOT (SAG, STRETCHINESS)

NOTE: Does not respond promptly when throttle is opened quickly.

### GENERAL

Poor fuel quality.  
Vapor lock. (11)  
Late ignition timing.

### MECHANICAL

Accelerator pump linkage adjustment incorrect.  
Accelerator linkage faulty or improperly adjusted.

### FUEL

Low fuel pump pressure.  
Accelerator pump piston or diaphragm leaks.  
Accelerator pump valves leak or passages restricted.  
Float level incorrect.  
Defective fuel pump.  
Carburetor defective or improperly set.  
Fuel filter plugged.  
Dirt in carburetor jets.

---

## BACKFIRES, POPPING BACK OR SPITBACK THROUGH CARBURETOR (SUBDUED EXPLOSION IN INTAKE MANIFOLD)

### GENERAL

Cold engine and choke too lean.  
Loose carburetor mounting bolts. (9)  
Loose intake manifold bolts. (9)  
Incorrect timing and dwell.  
Vacuum leaks (hoses etc.). (9)

### IGNITION

Leaking distributor cap may cause backfire to occur in cylinder on intake stroke.  
Two crossed spark plug wires may also cause backfire through carburetor.

### FUEL

Lean mixture.  
Dirt or water in fuel.  
Faulty accelerator pump.

### MECHANICAL

Leaky or sticky intake valve.  
Weak or broken intake valve spring.  
Faulty heat valve.  
Plugged heat crossover passage.  
Improper camshaft timing.  
Improper valve lash.

---

## AFTER-BURNING OR MUFFLER EXPLOSION (BACK FIRE)

NOTE: A subdued put-putting at the exhaust tailpipe may be due to leaky exhaust valves which permit the mixture to finish combustion in the muffler. If exhaust pipe or muffler is red hot, better let it cool, as there is some danger of setting the vehicle on fire. Most likely to occur when mixture is lean.

### GENERAL

Late timing.  
Burnt exhaust valve.  
Air cleaner restricted.  
Air leak in exhaust manifold or pipe.

### MECHANICAL

Late valve timing.  
Worn or broken exhaust valve spring.  
Tight exhaust valve.  
Choke stuck closed.



**IGNITION**

Intermittent open circuit in primary.  
(Ammeter needle swings further away from zero when generator is charging.)

Intermittent short in primary. (Ammeter swings toward zero when generator is charging.)

Short in coil or secondary coil wire.

If just a couple of explosions are heard and then no more for a time (even for days) the trouble may be due to a gradually failing condenser.

**FUEL**

Carburetor flooding.

**SMOKE****WHITE**

Condensing water vapor which is a normal product of combustion—no problem—usually seen on cold days.

**BLACK**

Excessively rich fuel mixture.  
(See "Excessive Fuel Consumption".)

**BLUE****(Or Bluish White)**

Excessive oil consumption  
(See "Excessive Oil Consumption")

**EXCESSIVE FUEL CONSUMPTION (1)****GENERAL**

"Jack Rabbit" starts.  
High speed.  
Short drives.  
Restricted Choke (partly closed).  
Clogged air cleaner.  
Loss of compression.  
Excessive rolling resistance from low tires, dragging brakes, wheel misalignment, etc.

Restricted exhaust.  
Engine overheating.  
Crankcase ventilating system faulty.  
Trailer towing.  
Worn-out or badly tuned engine.

**IGNITION**

Faulty ignition system.

**FUEL**

Excessive fuel pump pressure.  
Float level high. (4)  
Faulty carburetor.  
Leakage or loose fittings.  
Idle speed settings incorrect.  
Accelerator pump improperly adjusted.

**MECHANICAL**

Faulty valves or valve train.  
Faulty rings.  
Choke mechanism binding or improperly adjusted.  
Accelerator linkage binding or improperly adjusted.  
Fuel tank cap missing.

**LOW OIL PRESSURE****GENERAL**

Low oil level.  
Clogged oil filter.  
Thin or diluted oil (frequent stops in cold weather).

Viscosity (too light grade).  
Oil has foam from water (condensation or leaking head gasket).  
Overheating.

## MECHANICAL

Faulty pressure sending unit, line, or gauge.  
 Worn oil pump.  
 Excessive bearing clearance.  
 Oil pump relief valve dirty, worn, spring weak or worn.

Oil pump suction tube loose or cracked.  
 Screen clogged (ice, gummy, sludge or dirt).  
 Air leak in oil pump (loose cover or too thick gasket).  
 Loose connections in oil lines.

---

## HIGH OIL PRESSURE

### GENERAL

Oil too heavy (viscosity).  
 Main oil passage on pressure side of pump clogged.

### MECHANICAL

Faulty gauge.  
 Oil pressure relief valve adjustment too heavy.  
 Relief valve spring too stiff.  
 Oil pressure passage clogged.

---

## NO OIL PRESSURE WHILE IDLING

### GENERAL

Faulty oil gauge sending unit.  
 Leakage at internal oil passage.

### MECHANICAL

Oil pump not functioning properly. (Valve stuck by foreign material.)  
 Excessive clearance at bearings (camshaft, rod or main).

---

## NO OIL PRESSURE WHILE ACCELERATING

### GENERAL

Low oil level in oil pan.

### MECHANICAL

Leakage at internal oil passages.

---

## NO OIL PRESSURE

### GENERAL

Suction loss.  
 Oil pressure gauge faulty.  
 Not enough oil in pan.  
 Pipe to oil pressure gauge stopped up.  
 Oil passage on discharge side of pump stopped up.

Oil screen or passages on intake side of pump stopped up.

### MECHANICAL

Oil pump inoperative.  
 Relief valve stuck open.

## BURNED, STICKING OR BROKEN VALVES

### GENERAL

Over-speeding engine.  
Deposits on valve seats and/or gum formation on stems or guides.  
Warped valves or faulty valve forgings.  
Exhaust back pressure.  
Improper ignition timing.

### MECHANICAL

Weak valve springs.  
Improper valve clearance.  
Improper valve guide clearance and/or worn valve guides.  
Out-of-round valve seats or incorrect valve seat width.

## EXCESSIVE OIL CONSUMPTION

**NOTE:** Check the PCV valve for proper operation before checking causes of leak. A clogged crankcase vent valve can build up pressure in the crankcase which will cause seals and gaskets to leak.

### EXTERNAL LEAKAGE

Oil pan drain plug loose or gasket missing.  
Crack or hole in oil pan.  
Oil pan gasket leaks due to:

- (a) Loose screws; (b) Damaged gasket;
- (c) Improperly installed gasket;
- (d) Bent oil pan flange.

Oil pan gasket leaks due to:

- (a) Loose screws; (b) Damaged gasket;
- (c) Improperly installed gasket;
- (d) Bent oil pan flange.

Timing case cover gasket leaks due to:

- (a) Loose screws; (b) Damaged gasket;
- (c) Improperly installed gasket;
- (d) Bent cover flange;

Front crankshaft oil seal leaks due to:

- (a) Worn oil seal; (b) Seal not properly installed; (c) Rough surface on crankshaft, or fan pulley or damper;
- (d) Damper or pulley loose; (e) Seal or cover not centered on crankshaft; (f) Oil return passage to crankcase clogged up.

Rear main bearing oil seal leaks due to:

- (a) Worn oil seal; (b) Improper oil seal installation; (c) Worn rear main bearing;
- (d) Rough crankshaft. Oil passage to crankcase clogged.

Expansion plug in block at rear of camshaft leaks due to poor fit, careless installation, or corrosion.

Leakage at any external piping.

Plugs at ends of oil passages in cylinder block leak.

Oil filter leaks.

Leakage at distributor housing.

Valve cover leaks due to loose screws, defective gasket, improperly installed gasket or bent cover flange.

Rocker arm cover or push rod cover leaks due to loose screws, defective gasket, improper gasket installation or bent cover flange.  
Pipe connections loose on oil gauge or oil filter lines.

Improperly seated or broken fuel pump gasket.

Broken push rod cover gasket, oil filter gasket, or timing chain cover gasket.

Worn timing chain cover oil seal.

Worn or improperly seated rear main bearing oil seal.

Loose oil line plugs.

Rear camshaft bearing drain hole plugged.

Loose rocker arm cover, gasket broken, or cover distorted or bent.

Rear main bearing side seal improperly installed.

### INTERNAL LEAKAGE

Carbon in oil ring slot.

Rings fitted too tight in grooves.

Leaky piston rings due to wear, scuffs or broken.

Leaky piston rings due to sticking caused by gummy deposit. Try to free up with suitable solvent poured in fuel tank, Blue smoke at tail pipe indicates badly leaking rings.

Worn pistons and cylinders.

Cylinder block distorted by tightening cylinder head bolts unevenly.

Excessive clearance between intake valve stems and guides allows oil mist to be sucked into cylinders.

Worn main or rod bearings allow excessive leakage from bearings.

Result in cylinder walls are flooded with oil.

Oil pressure too high due to faulty action of oil pressure relief valve, or clogged relief passage.

If pressure lubricated, loose piston pins may permit excessive leakage to cylinder walls.

Grade of oil used is too light. A poor quality oil may become far too thin when engine is hot. Hard driving on hot days will also consume more oil.

Clogged crankcase ventilator system.  
Intake valve seals damaged or missing.  
Plugged drain back holes in head.  
Intake manifold gasket leak in conjunction with rocker cover gasket leak.  
Ring grooves or oil return slots clogged.

Rings sticking in ring grooves of piston.  
Ring grooves worn excessively in piston.  
Compression rings installed upside down.  
Excessively worn or scored cylinder walls.  
Cylinder walls not properly honed or finished.

Oil too thin (diluted).  
Oil level too high.  
Excessive main or connecting rod bearing clearance.

Piston ring gaps not staggered.  
Incorrect size rings installed.  
Piston rings out-of-round, broken or scored.  
Insufficient piston ring tension due to engine overheating.

## ENGINE NOISY

**NOTE:** When diagnosing engine noise problems, be careful that noises caused by accessories are not mistaken for engine noises. Removal of accessory drive belts will eliminate any noises caused by these units.

In general, engine noises are either synchronized to engine speed or one-half engine speed. Those that are timed to engine speed are sounds that have to do with the crankshaft, rods, pistons, and wrist pins. The sounds emitted at one-half engine speed are valve train noises.

The use of a stethoscope will often aid in locating an engine noise. Caution must be exercised, however, because noise will travel to other metal parts not involved in the problem. A timing light will aid in determining if the noise is synchronized with engine speed or at one-half engine speed.

Engine noise sometimes may be isolated by grounding the spark plug leads one at a time. If the noise lessens appreciably or disappears, it is confined to that particular cylinder.

No definite rule or test can be listed that will positively determine the source of a noise complaint.

Fuel pumps, distributors, flywheels, water pumps, drive belts, or carbon built up in the combustion chamber may contribute to noisy engine operation. The following information can therefore, be used only as a general guide to noise diagnosis. There is no substitute for experience.

### A. NOISY MAIN BEARINGS

**NOTE:** A loose main bearing is indicated by a powerful, but dull, thud or knock when the engine is pulling. If all main bearings are loose a noticeable clatter will be audible.

The thud occurs regularly every other revolution. The noise is loudest when the engine is "lugging" or under heavy load. The sound is heavier and duller than a connecting rod noise. Low oil pressure also accompanies this condition. The knock can be confirmed by shorting spark plugs on cylinders adjacent to the bearing. Knock will disappear or be less when plugs are shorted.

This test should be made at a fast idle equivalent to 15 mph. If bearing is not quite loose enough to produce a knock if oil is too thin or if there is no oil at the bearing.

Regular noise: worn main bearings; irregular; worn end-thrust bearings.

## GENERAL

Insufficient oil supply.  
Low oil pump pressure.  
Thin or diluted oil.

## MECHANICAL

Excessive bearing clearance.

Excessive crankshaft end play.  
Eccentric or out-of-round crankshaft journals.

Sprung crankshaft.  
Excessive belt tension.  
Loose harmonic balancer.  
Loose flywheel or torque converter.

**IMPORTANT:** Crankshaft End Play - Intermittent rap or knock that is sharper than a loose main bearing. Repeated disengagements of the clutch may cause a change in the rap.

## B. NOISY ROD BEARINGS

**NOTE:** Rods with excessive clearance knock under all speeds and under both idle and load conditions. At the early stage of looseness, rod noise may easily be confused with piston slap or loose pins. Rod knock noise increases in intensity with engine speed. Low oil pressure also accompanies this condition.

## GENERAL

Excessive bearing clearance.  
Worn crankpin.  
Lack of oil (thin or diluted).  
Low oil pressure.  
Journals out-of-round.

(A metallic knock which is usually loudest at about 30 mph with throttle closed. Knock can be reduced or even eliminated by shorting spark plug. If bearing is not loose enough to produce a knock by itself, the bearing may

knock if oil is too thin or if there is no oil at the bearing.)

## MECHANICAL

Misaligned rod.  
Connecting rod bolts not tightened correctly. (Should connecting rod misalignment be suspected, check for a diagonal wear pattern on the piston skirt, and for excessive wear on the opposite edges of the connecting rod bearings.)

**IMPORTANT:** Automatic transmission coupling noise caused by loose transmission-to-engine bolts sounds like rod bearing noise.

## C. NOISY TIMING GEARS

**NOTE:** A high frequency light knock difficult to isolate without a sound detecting device. It is about the same intensity whether the engine is idling or at high speeds or under load.

**GENERAL**

Gears misaligned.  
Excessive backlash.  
Chipped tooth—usually camshaft gear.

**MECHANICAL**

Gears loose on hubs or shafts.  
Eccentric gear, usually due to high keys.  
Teeth meshed too tight (new oversize gear).  
Too much end play in camshaft or crankshaft.  
Front camshaft bearing clearance excessive.

**D. NOISY TIMING CHAIN****GENERAL**

Chain loose due to wear.  
Sprocket teeth worn.  
Sprockets misaligned.  
Loose vibration damper or drive pulley.

**MECHANICAL**

Sprocket loose on hubs or shaft.  
Front camshaft bearing clearance excessive.  
Front main bearing clearance excessive.

**E. NOISY PISTONS**

**NOTE:** Piston pin, piston and connecting rod noises are difficult to tell apart. A loose piston pin causes a sharp double knock which is usually heard when engine is idling. Severity of knock should increase when spark plug to this cylinder is short-circuited. However, on some engines the knock becomes more noticeable at 25 to 35 mph on the road. Piston pin rubs against cylinder wall, caused by lock screw being loose or snap ring broken

**GENERAL**

Worn or loose piston pin or bushing.  
Improper fit of pin.  
(Listen for a light ticking or tapping noise. More noticeable with no load on engine. May disappear completely under load. Generally piston pin noise can be noticed on deceleration of the engine.)

Piston-to-cylinder bore clearance excessive.

(Sounds very similar to tappet or lifter noise. Removing one spark plug wire at a time may be helpful in determining which cylinder is noisy. One indication of piston slap is a decrease in noise as the engine warms up. Piston slap is always louder when the engine is cold. Retard timing slightly, noise should decrease.)

Lack of lubrication.

Carbon deposits on top of piston strikes cylinder head.

Worn or broken piston ring land. (Most noticeable during acceleration.)

Broken or cracked piston.  
Engine overheating.  
Fuel of too low octane rating.  
Operating without air cleaner.

**MECHANICAL**

Excessive rod bearing clearance.  
Misaligned connecting rods.  
Worn rings, cylinder walls, low ring tension, broken rings, out-of-round or tapered bores.  
Top of piston strikes ridge at top of cylinder bore.  
Piston rubs against cylinder head gasket.  
Excessive side clearance of rings in groove, clearance between ring and groove and/or ring gap.  
Undersize pistons installed.  
Wrong type and/or size rings installed.  
Cylinder bores tapered or eccentric.  
Pins improperly assembled.  
Insufficient ring gap clearance.  
Pistons 180° out of position.

## F. NOISY VALVE MECHANISM

### GENERAL

Sticking or warped valves.  
 Bent push rods.  
 Dirty, worn, or scored parts.  
 Broken or weak springs.  
 Damaged valve lifter and/or camshaft lobes.  
 Insufficient or poor oil to valve mechanism. (Thin, foaming, or diluted.)  
 Excessive valve stem-to-guide clearance.

Valve lifter incorrectly fitted to bore size.

Pulled or loose rocker arm bolts.

### MECHANICAL

Hydraulic lifter not working properly or faulty. (Faulty lifter can usually be located with the aid of a stethoscope.)

Hydraulic lifter "pumped up" from excessive speed-temporary noise.

## G. NOISY WATER PUMP

**NOTE:** Listen for a ratchety or grinding sound which increases with engine rpm. In the early stages, the grinding noise may disappear at higher engine rpm. Disconnect the fan belt, and run engine. If noise disappears, trouble most likely is the water pump bearing. Bearing failure or start of failure can be detected by grasping the water pump pulley with both hands and moving it in a sidewise motion. If sloppiness is present, the bearing is unserviceable.

### GENERAL

Rough bearing.  
 Pump seal too hard.

### MECHANICAL

Shaft pulley loose.  
 Impeller loose on shaft.

Too much end play in pump shaft.  
 Too much clearance between shaft and bearings.

Impeller blades rubbing against pump housing.

Impeller pin sheared off.  
 Impeller broken.

## H. NOISY GENERATOR

(Refer to Generator Diagnosis Charts)

### GENERAL

Brush squeal.  
 Bearings.  
 Faulty diode or stator.

### MECHANICAL

Loose mounts.  
 Belt too tight.

## I. NOISY FAN

### GENERAL

Fan blades bent.  
 Fan out-of-balance when made.  
 Fan shaft end play excessive.

### MECHANICAL

Fan blades loose on clutch.  
 Fan blades strike shroud.

## J. NOISY FUEL PUMP

**NOTE:** Diagnosis of fuel pumps suspected as noisy, requires that some form of sounding device be used. Judgment by ear alone is not sufficient, otherwise a fuel pump may be needlessly replaced in attempting to correct noise contributed by some other component. Use of a stethoscope, a long screwdriver, or a sounding rod is recommended to locate the area or component causing the noise. The sounding rod can easily be made from a length of copper tubing 1/4 to 3/16 inch in diameter. Dowel rods are also good.

If the noise has been isolated to the fuel pump, remove the pump and run the engine with the fuel remaining in the carburetor bowl. If the noise level does not change, the source of the noise is elsewhere and the original fuel pump should be reinstalled.

## K. NOISY FAN BELT

### GENERAL

- Belt worn or burned.
- Wrong belt. Does not fit pulley grooves properly.
- Belt or pulley dirty or sticky with gummy oil.
- Pulley bent, cracked or broken.

### MECHANICAL

- Belt too tight. Squeaks.
- Belt pulleys misaligned.
- Belt loose; squeaks when engine is accelerated.

## L. MISCELLANEOUS NOISE

(Rattles, squeaks, etc., from loosely mounted accessories; generator, horn, oil pan, etc.)

### LOOSE FLYWHEEL

A thud or click which is usually irregular. To test, idle the engine at about 20 mph and shut off the ignition. If thud is heard, the flywheel may be loose.

### EXCESSIVE CRANKSHAFT END PLAY

A rather sharp rap which occurs at idling speed but may be heard at higher speeds also.

### FAN SHROUD

Loose shroud or radiator.

### ENGINE VIBRATION

- Unequal compression in cylinders.
- Missing at high speed.
- Unbalances fan or loose fan blade.
- Incorrect adjustment of engine mounts, or damaged mounts.
- Loose engine mounts.
- Engine support loose on frame or cylinder block.
- Unbalanced or sprung crankshaft.
- Excessive engine friction due to tight piston etc.
- Defective vibration damper.

### LOOSE ENGINE MOUNTINGS

Occasional thud with vehicle in operation. Most likely to be noticed at the moment the throttle is opened or closed.



## M. PRE-IGNITION OR SPARK KNOCK

(Most noticeable under heavy acceleration)

### GENERAL

- Low octance fuel being used.
- Muffler or exhaust passage restricted.
- Excessive carbon deposit in combustion chamber.
- Hot spot in head—possibly caused by foreign matter clogging small water passages between head and block.
- Engine lugging—produces unbalanced heat.
- Compression too high for octane rating of fuel being used.
- Overheated spark plug due to being too “hot” for the application, not seated properly, or not torqued to specifications.

### IGNITION

- Faulty ignition system or timing advance beyond specifications.
- Dwell angle (or gap) too low.

### FUEL

- Carburetor mixture lean.
- Operating with standard specifications at high altitudes allowing rich fuel mixture.

## GENERAL ENGINE CHECKS

### 1. EMISSION CONTROL CHECK

To diagnose Emission Control Systems, refer to “Emission Control Charts” in this manual.

### 2. BATTERY CHECK

The battery must be fully charged before proceeding with engine diagnosis. When the battery has a low charge, determine and repair the cause of the low charge before proceeding with further diagnosis. Refer to “Battery Diagnosis Charts” in this manual.

### 3. CHOKE CHECK

Freedom of operation may be checked by holding the throttle in the open position and manually operating the automatic choke linkage. When possible, choke linkage should be checked on a cold carburetor. Refer to “Carburetor Diagnosis Charts” in this manual.

### 4. FLOODING CHECK

Flooding occurs when an excessive amount of fuel enters the cylinders and prevents ignition. If flooding is suspected, look for wet throttle plates, external leakage around the throttle plate shaft, ex-

ternal leakage at the bowl gasket and/or wet spark plugs. If the engine is running, a flooding condition will be indicated by a rough engine idle, poor acceleration, and heavy, black smoke from the exhaust system. Flooding is usually caused by improper operation of the carburetor fuel inlet system or a high float level setting. Additional causes are listed in “Carburetor Diagnostic Procedures” in this manual.

### 5. CARBURETOR ICING CHECK

Carburetor icing generally occurs when ambient temperatures range from 30°F. to 50°F., and the relative humidity is above 60%. Moisture from in-rushing air collects and freezes between the throttle plates and the throttle base, cutting off the air supply to the engine, and stalling the engine.

If icing occurs after the engine is at normal operating temperature, allow the engine to stand for a short period of time. The carburetor casting will absorb enough heat from the engine to thaw the ice. If the icing occurs while the engine is still cold, the ice may be melted by pouring a small amount of anti-icing additive directly into the carburetor. Neither of the above procedures will prevent a recurrence of the icing condition.

The most effective way to prevent icing is to add an anti-icing additive to the fuel.

## 6. SPARK INTENSITY CHECK

Disconnect a spark plug wire and install a terminal adapter in the terminal of the wire to be checked. Hold the adapter approximately 1/8" away from the exhaust manifold and crank the engine. The spark should jump the gap regularly and be blue in color. A good spark indicates that the ignition primary and secondary circuits are functioning properly. A weak spark (usually a pale orange color) or an intermittent spark indicates trouble within the primary and/or secondary ignition circuits.

## 7. HARD STARTING ENGINE CHECK

The problem of an engine that cranks normally but starts hard when cold can usually be traced to an excessively lean fuel mixture. Excessively lean fuel mixtures are usually caused by an improper choke setting or as insufficient amount of fuel being delivered to the cylinders.

If the engine starts OK cold, but is hard to start when hot, the problem may be due to an excessive amount of fuel being discharged through the carburetor. A hot engine hard start or no start condition may also be due to the coil breaking down after it becomes heated. Hard starting occurring only after a hot engine has been shut down for a few minutes, indicates carburetor percolation or vapor lock which causes a rich fuel condition. Refer to "Carburetor Diagnosis Charts" in this manual, for individual fuel problems. (Corroded or loosened terminal could be the cause.)

If the engine starts hard regardless of whether it is hot or cold, the problem can usually be traced to engine compression, fuel system, or ignition system. Refer to "Ignition System" or "Fuel System Diagnosis" charts in this manual for ignition and/or fuel problems.

## 8. ACCELERATING PUMP DISCHARGE CHECK

Remove the air cleaner and manually operate the throttle linkage while observing the fuel discharge from the accelerator pump nozzles. When the throttle plates are opened, a quick steady stream of fuel should be discharged into the carburetor. Failure of the accelerator pump to discharge a sufficient amount of fuel usually indicates a problem in the fuel delivery system between the supply tank and the carburetor. Refer to "Fuel Pump and/or Carburetor

Diagnosis" charts in this manual. Insufficient fuel discharge, however, may also be due to the operation of the accelerator pump circuit within the carburetor.

## 9. VACUUM LEAKAGE CHECK

With the engine at idle speed, squirt a mixture of kerosene and 10W motor oil around areas where vacuum leakage may occur. A noticeable change in the engine idle when the mixture is squirted on a given point indicates a vacuum leak at that point.

**CAUTION:** *Kerosene and oil mixture is flammable. Careless application may result in fire. DO NOT use gasoline.*

## 10. EXCESSIVE FUEL CONSUMPTION CHECK

There are a number of factors, other than engine or carburetor problems, that will contribute to excessive fuel consumption. One of the most important of these is the driving habits of the operator.

When the operator habitually makes "jack-rabbit" starts and stops, "rides" the brake pedal, overloads the vehicle, drives at excessively high speeds for prolonged periods, fails to hold a consistent throttle position. (continuously accelerates, then coasts) and/or operates the vehicle under short run conditions (cold engine) the majority of the time, this could be the problem.

Vehicle air resistance at high speeds has a major affect on fuel consumption. Head winds, excessively high speeds, or added protrusions to the vehicle profile will cause an increase in fuel consumption.

When it has been determined that the operator is not at fault, make a fuel consumption test using a calibrated fuel measuring device. The amount of fuel used to drive the vehicle a measured distance should be recorded. Then record the amount of fuel used to return to the starting point. An average of the two readings should be used in determining the existence of a fuel consumption problem. While making the fuel consumption test, the vehicle odometer should be checked over a measured mile for proper calibration.

If the results of the fuel consumption test indicate that a fuel consumption problem does exist, the diagnostic procedures outlined in this manual under "Excessive Fuel Consumption in Carburetor" and/or "Ignition Diagnosis" charts should be followed.

## 11. VAPOR LOCK CHECK

The term "vapor lock" means the flow of fuel to the mixing chamber in the carburetor has been stopped (locked) by the formation of vaporized fuel pockets or bubbles caused by overheating the fuel by hot fuel pump, hot fuel lines or hot carburetor.

The more volatile the fuel the greater the tendency for it to vapor lock. Vapor lock is encouraged by high atmospheric temperature, hard driving, defective engine cooling and high altitude.

A mild case of vapor lock will cause missing and hard starting when engine is warm; also a "sag" during an acceleration or surge during cruise. Somewhat more severe vapor lock will stop the engine which cannot be started again until it has cooled off enough so that any vaporized fuel has condensed to a liquid.

**IMPORTANT:** Percolation means simply that gasoline in the carburetor bowl is boiling over into the intake manifold. This condition is most apt to occur immediately after a hot engine is shut off. The carburetor has provision for relieving the vapor pressure of overheated fuel in the carburetor bowl by means of internal vents. If, however, percolation should take place, the engine may be started by allowing it to cool slightly and then holding the throttle wide open while cranking to clear the intake manifold of excess fuel.

Some causes of vapor lock may be due to winter grade fuel used in summer (most vapor lock occurs in April due to this), or temperature under hood is too high.

**NOTE:** Applying wet cloths to fuel lines, fuel pump and/or carburetor can cause fuel to condense and permit engine to run.

## IN-VEHICLE SERVICE OPERATIONS

### ENGINE OIL PRESSURE TEST (FIGURE 3)

1. Remove oil pressure warning light switch from the left front of the engine.
2. Install oil pressure gauge in hole.
3. Set parking brake. Put transmission selector in "N", neutral position.
4. Start engine and run until normal operating temperature is obtained.
5. Oil pressure should be at idle - 7psi min. 1500-3000 rpm - 35psi min.

5. Remove oil filter extension fitting and adaptor.

6. Remove three (3) bolts securing base to engine block.

7. Remove filter base and gasket.

### OIL FILTER (FIGURE 4)

#### REMOVAL

1. Hoist motor home.
2. Remove oil filter.
3. Loosen oil cooler line clamp bolt. See Figure 2.
4. Loosen oil cooler line fittings from the adapter and slide lines forward approximately one inch.

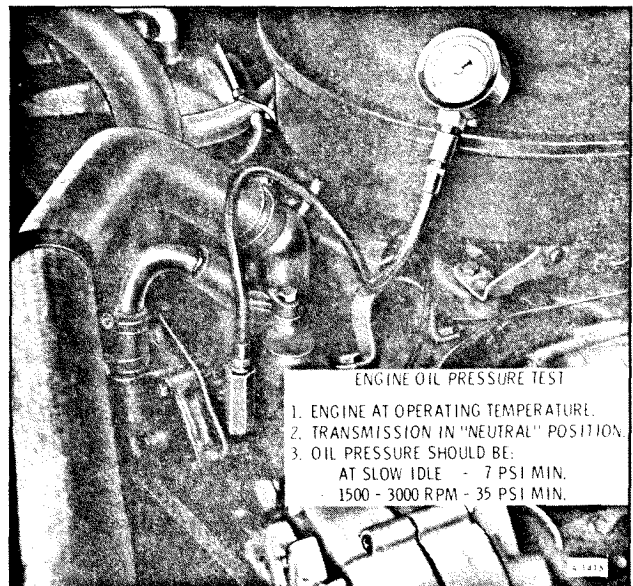

ENGINE OIL PRESSURE TEST

1. ENGINE AT OPERATING TEMPERATURE.
2. TRANSMISSION IN "NEUTRAL" POSITION.
3. OIL PRESSURE SHOULD BE:  
AT SLOW IDLE - 7 PSI MIN.  
1500 - 3000 RPM - 35 PSI MIN.

Figure 3—Checking Engine Oil Pressure

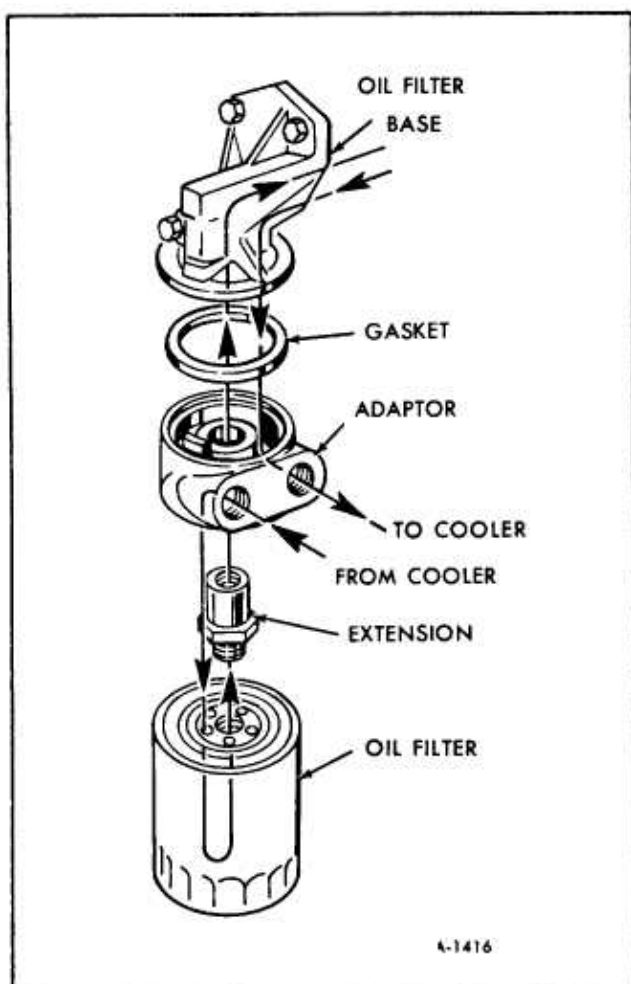

Figure 4—Oil Filter

## INSTALLATION

1. Install gasket and filter base to engine block. Torque bolts to 35 ft. lbs.
2. Install adaptor and oil filter extension fitting. Torque fitting to 55 ft. lbs.
3. Reposition oil cooler lines and attach to adaptor.
4. Torque cooler line clamp bolt to 9 ft. lbs.
5. Apply a film of engine oil to the filter gasket and install torque by tightening 2/3 turn after gasket contacts adaptor.

**NOTE:** If a new oil filter is being installed, add one quart of oil.

6. Start engine, check for possible leaks. Stop engine and after several minutes check for proper engine oil level.

## FRONT ENGINE MOUNTS

### REMOVAL

1. Disconnect coil bracket from engine.
2. Attach engine lift tool No. J-24603 as shown in Figure 5.
3. Remove bolts "A" and "B". Remove nuts "C" and "D" as shown in Figure 6.
4. Adjust tool No. J-24603 so that the front of the engine is raised just enough to enable removal of support cushion.
5. Remove engine support cushion.

### INSTALLATION

1. Install new studs into engine support cushion and torque to 30 ft. lbs.
2. Install engine support cushion into place.
3. Lower engine making sure holes in engine support line up with holes in engine support cushion.
4. Install bolts "A" and "B" and torque nuts to 45 ft. lbs.
5. Install nuts "C" and "D" and torque to 30 ft. lbs.
6. Remove tool No. J-24603, connect coil bracket to engine. Install air cleaner and engine cover.

## REAR ENGINE MOUNTS

### REMOVAL

1. Disconnect coil bracket from engine.
2. Attach engine lift tool No. J-24603 as shown in Figure 5.
3. Remove bolts "A", "B" and "C" on both sides of the engine/transmission rear support (See figure 7).
4. Adjust tool No. J-24603 so that the rear of the transmission is raised and there is enough clearance to remove the engine restrictor and transmission mount.



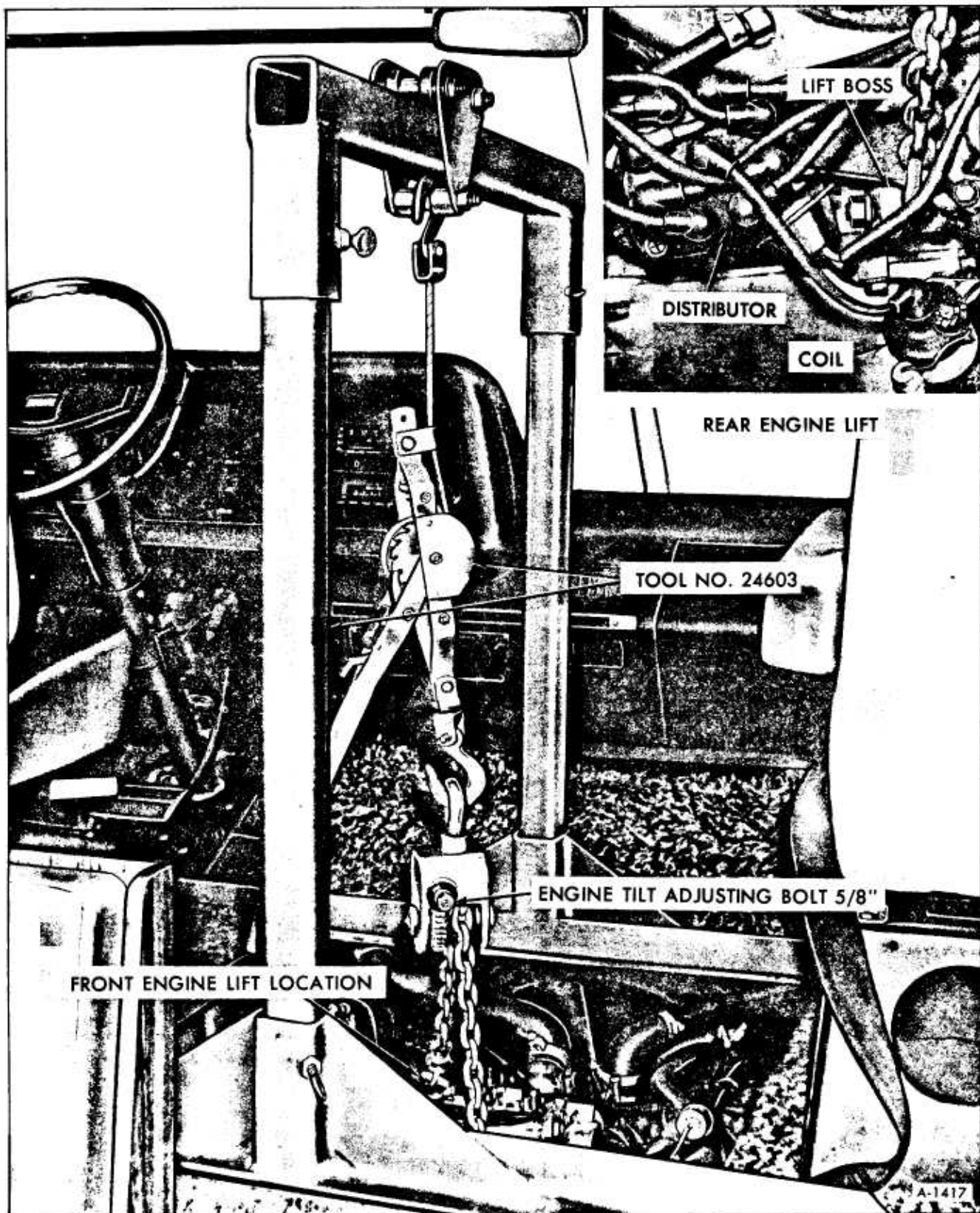

Figure 5-Attaching Engine Removal Tool

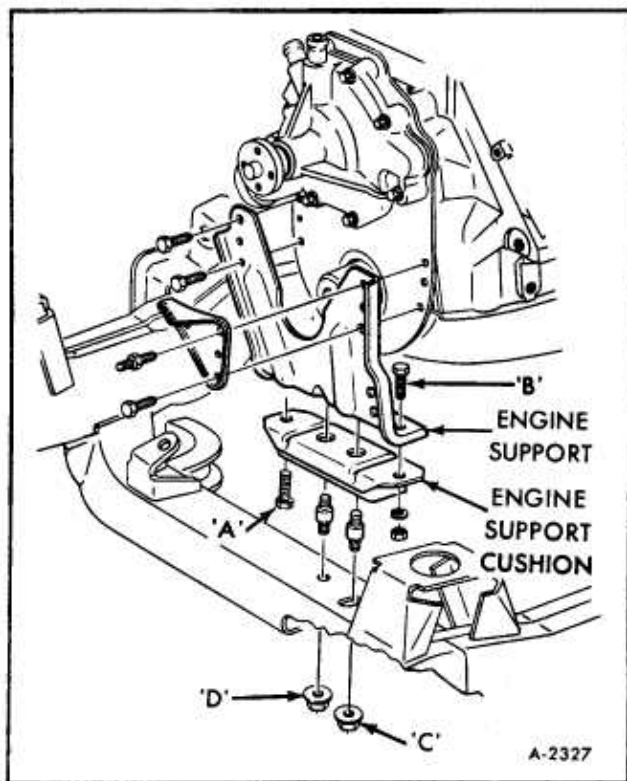

Figure 6—Front Engine Mounting

## INSTALLATION

1. Install engine restrictor and transmission mount.

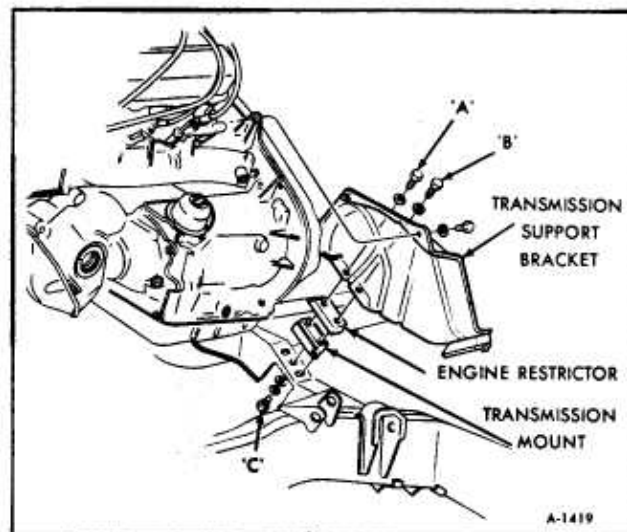

Figure 7—Engine Rear Mounting

2. Lower engine.

3. Install all bolts and nuts finger tight to insure proper alignment.

4. Torque bolts "A" and "B" to 50 ft. lbs. Torque bolt "C" to 55 ft. lbs.

5. Remove tool No. J-24603, connect coil bracket replace air cleaner, install engine cover.

## INTAKE MANIFOLD

### REMOVAL

1. Disconnect battery negative cables from both batteries.

2. Remove air cleaner assembly.

3. Drain radiator, then disconnect upper radiator hose and thermostat by-pass hose from water outlet. Disconnect heater hose at rear of manifold.

4. Remove both upper venturi ring braces on vehicles with air conditioning as shown on Figure 8. Vehicles without air conditioning require removal of L.H. upper venturi ring only.

5. If vehicle is equipped with the standard 61 amp. generator loosen belt and remove brackets shown in Figure 9.

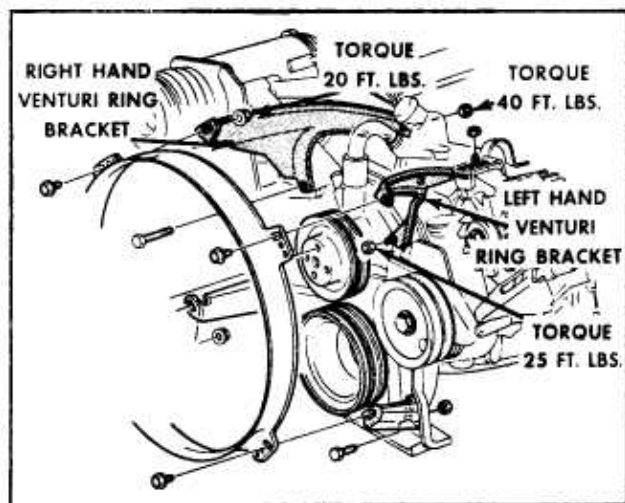

Figure 8—Upper Venturi Ring Brackets

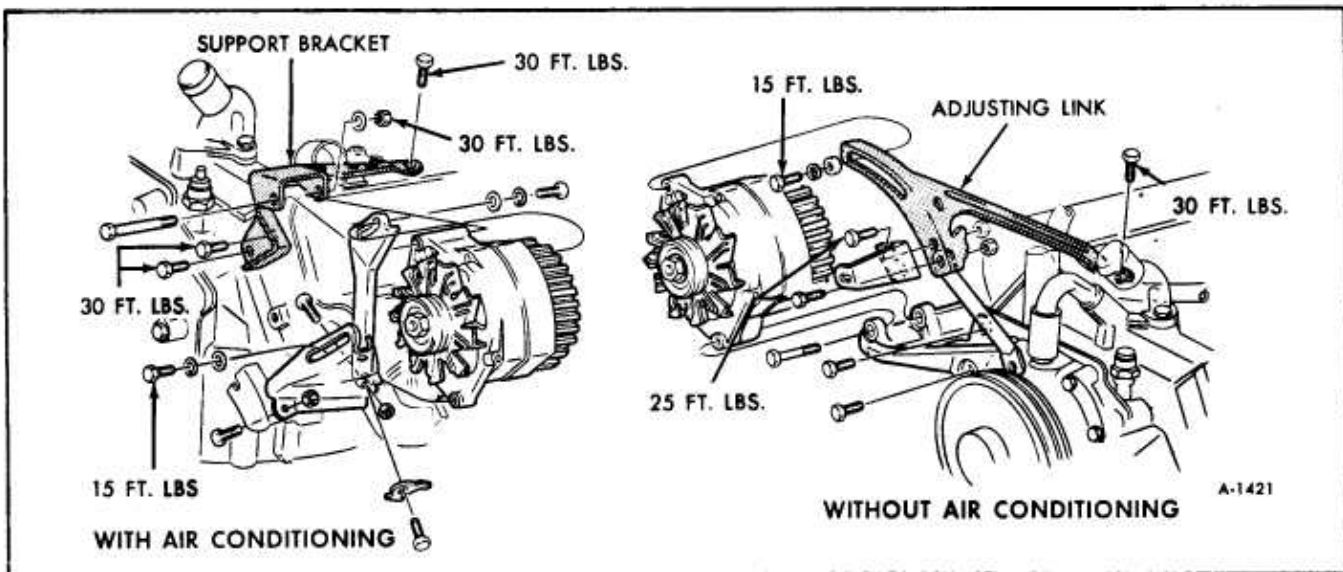

Figure 9-Generator Mounting

**NOTE:** Vehicles equipped with optional 80 amp. generator require no generator bracket removal.

6. Remove air conditioning compressor bracket (if so equipped). See Figure 10.

7. Remove engine oil filler lower tube and flexible elbow.

8. Disconnect temperature gauge wire.

9. Disconnect throttle cable, and cruise control rod (if equipped) from carburetor throttle lever. (See figure 11). Remove cruise control rod.

10. Remove fuel line from fuel pump to carburetor.

11. Disconnect vacuum lines from the distributor and tee as shown in Figure 12. Disconnect vacuum line from the front of the carburetor which leads to the carbon canister. Referring to Figure 11, disconnect from the intake manifold-vacuum lines to the brake booster (B), heater control (C) and cruise control (A) (if so equipped).

12. Pull PCV valve from grommet in the right valve cover.

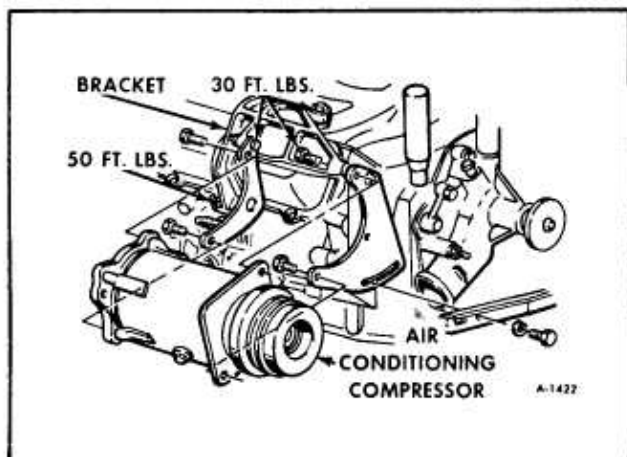

Figure 10-Air Conditioning Compressor Mounting

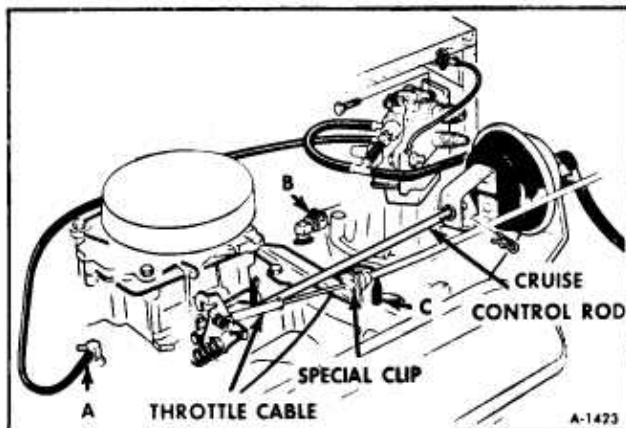

Figure 11-Location for Disconnecting Vacuum Hoses and Throttle Cable

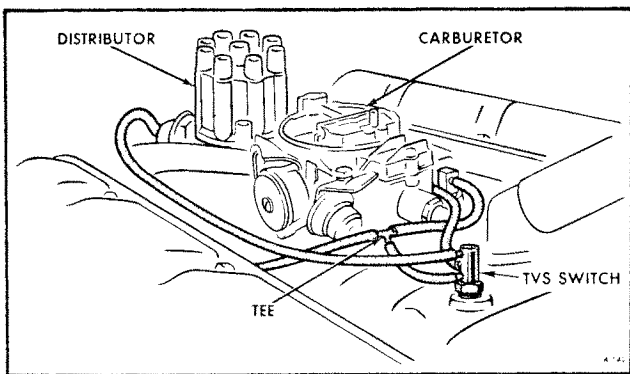

Figure 12—Distributor and Transmission Vacuum Lines

13. Disconnect spark plug cables that lead to cylinders No. 2, 4, 6 and 8 all on the right side, from the spark plugs. Disconnect distributor cap and carefully position cap and cables to the left and free of the work area.

14. Remove coil mounting bolts. Wires may be left connected to the coil if desired.

15. Remove intake manifold bolts, then remove manifold with carburetor attached.

16. Clean machined surfaces of cylinder head and intake manifold with a putty knife. Use care not to gouge or scratch machined surfaces.

## INSTALLATION

1. Coat both sides of intake manifold gasket at the sealing area with sealer 1050026 or equivalent. (See figure 13).

2. Install intake manifold. Lubricate bolts entirely with engine oil, install and torque to 15 ft. lbs. in sequence. See Figure 14. Retorque in sequence to 40 ft. lbs.

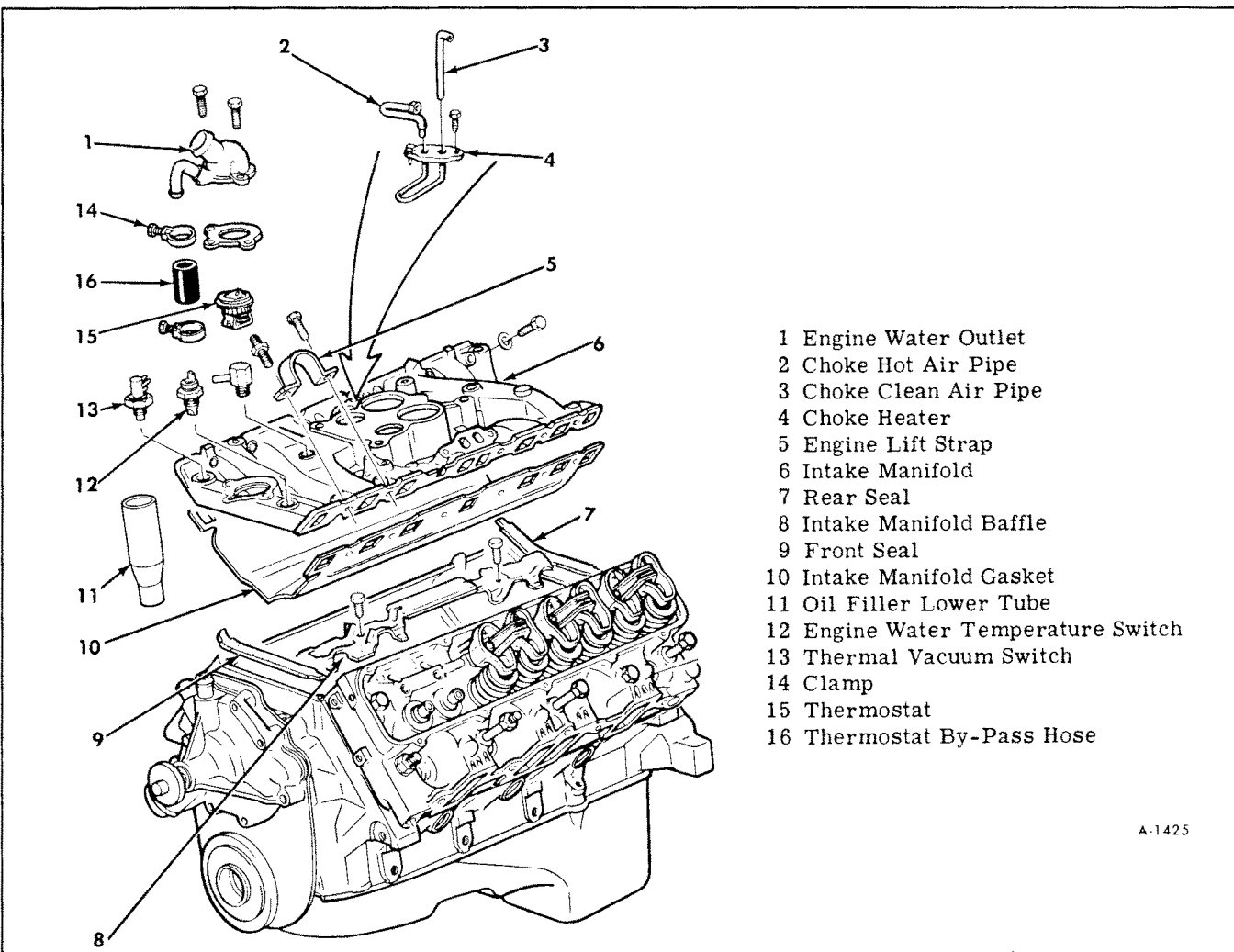

- 1 Engine Water Outlet
- 2 Choke Hot Air Pipe
- 3 Choke Clean Air Pipe
- 4 Choke Heater
- 5 Engine Lift Strap
- 6 Intake Manifold
- 7 Rear Seal
- 8 Intake Manifold Baffle
- 9 Front Seal
- 10 Intake Manifold Gasket
- 11 Oil Filler Lower Tube
- 12 Engine Water Temperature Switch
- 13 Thermal Vacuum Switch
- 14 Clamp
- 15 Thermostat
- 16 Thermostat By-Pass Hose

A-1425

Figure 13—Intake Manifold and Gasket



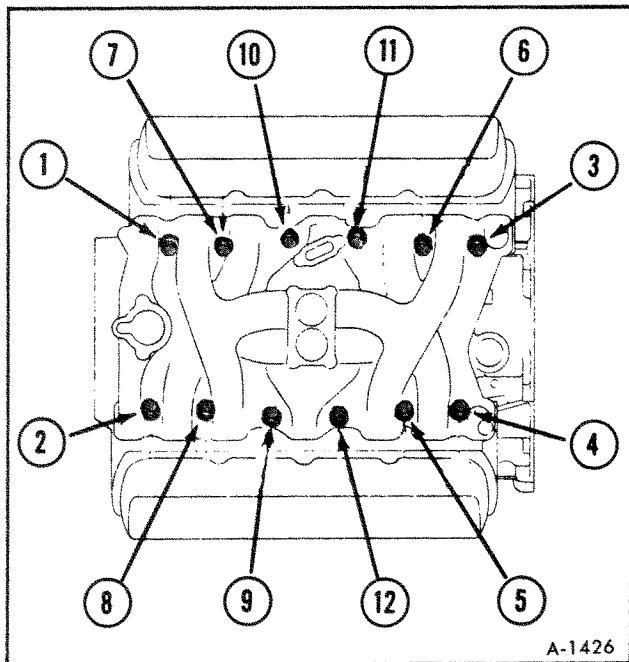

Figure 14—Intake Manifold Torque Sequence

3. Install coil mounting bolt and torque to 15 ft. lbs.

4. Install distributor cap and secure. Connect spark plug cables 2, 4, 6 and 8 on the spark plugs.

5. Install PCV valve into grommet on R.H. valve cover.

6. Connect vacuum lines to the distributor and tee as shown in Figure 12. Connect vacuum line to front of carburetor (from the carbon canister). Connect to the intake manifold vacuum lines, to the brake booster, heater control and cruise control (if equipped). See Figure 11.

7. Connect throttle cable, and cruise control (if equipped). See Figure 11.

8. Install fuel line.

9. Connect temperature gauge wire.

10. Install air conditioning bracket (if equipped). See Figure 10.

11. Install oil fill tube and flexible elbow.

12. Install generator mounting bracket, if removed. See Figure 9.

13. Adjust belt tension. Refer to "Belt Tension" later in this section.

14. Install venturi ring brace(s). See Figure 8.

15. Connect upper radiator hose, thermostat and by-pass hose to the water outlet. Connect heater hose at rear of manifold.

16. Install air cleaner.

17. Connect battery negative cables to the batteries.

18. Fill radiator. Start engine and check for leaks.

## L.H. EXHAUST MANIFOLD

### REMOVAL

1. Remove air cleaner.

2. Remove hot air shroud as shown in Figure 15.

**NOTE:** Shroud is attached to exhaust manifold by bolts No. 2 and 5.

3. Hoist vehicle.

4. Remove power steering or generator brackets as required.

5. Disconnect exhaust pipe.

6. Remove exhaust manifold.

### INSTALLATION

1. Position exhaust manifold on engine and install bolts No. 3 and 4 finger tight. (See figure 15).

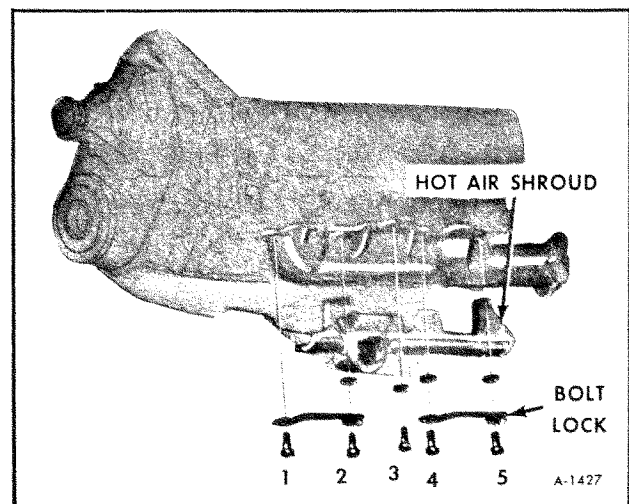

Figure 15—Hot Air Shroud

2. Position hot air shroud, power steering and generator braces (as required). Torque bolts to 25 ft. lbs. and bend tabs around bolt heads.

3. Install power steering and generator brackets, using stud "A". Torque to 25 ft. lbs.

4. Connect exhaust pipe and tighten pipe to manifold bolts until they bottom on spacer.

5. Lower vehicle.

6. Install air cleaner.

## R.H. EXHAUST MANIFOLD

### REMOVAL

1. Hoist vehicle.
2. Disconnect exhaust pipe.
3. Remove exhaust manifold.

### INSTALLATION

1. Install exhaust manifold and torque bolts to 25 ft. lbs. Bend tabs around bolt heads.

2. Connect exhaust pipe and tighten pipe to manifold bolts until bolts bottom on spacers.

3. Lower vehicle.

## VALVE COVER

### REMOVAL

1. Remove air cleaner.
2. Disconnect positive crankcase ventilation from valve cover (R.H. only).
3. Disconnect spark plug cables from spark plugs and move back and out of the way.
4. Loosen belts and remove accessories and mounting brackets as necessary. Vehicles with air conditioning, it will be necessary to wire the air conditioning compressor up for support after removing its bracket. See Figure 10.

**NOTE:** Freon lines do not have to be disconnected from the compressor.

5. Remove valve cover to cylinder head attaching screws as shown in Figure 16.

6. Clean gasket surfaces on cylinder head and valve cover.

### INSTALLATION

1. Apply part No. 1050026 sealer or equivalent to the valve cover side and install a new gasket in the cover.

2. Install valve cover and torque attaching screws as shown in Figure 16.

3. Install accessories and mounting brackets as necessary. Adjust belt tension. Refer to "Belt Tension" later in this section.

4. Connect spark plug cables, and connect positive crankcase ventilation valve to cover (R.H. only).

5. Install air cleaner.

## ROCKER ARM ASSEMBLIES (FIGURE 17)

### REMOVAL

1. Remove valve cover. Refer to "Valve Cover" earlier in this section.

2. Remove rocker arm, flanged bolts, pivot and rocker arms.

**NOTE:** Remove each set (one set per cylinder) as a unit.

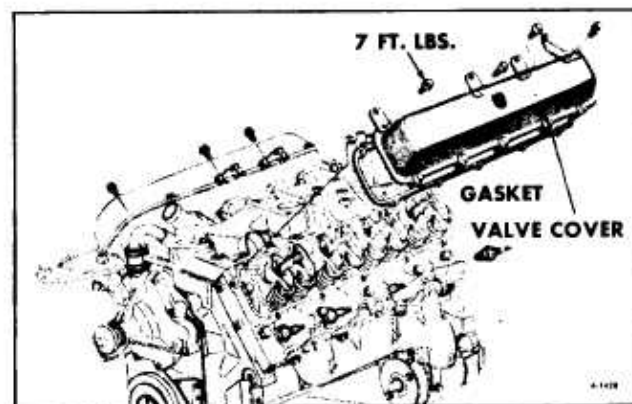

Figure 16-Valve Cover.

## INSTALLATION

1. Position a set of rocker arms (for one cylinder) in the proper location.
2. Lubricate wear points with 1050169 Lubricant or equivalent and install the pivots.
3. Install the hardened flanged bolts and tighten alternately. Torque bolts to 25 ft. lbs.

## VALVE LIFTERS

### OPERATION

Oil is supplied to the lifter through a hole in the side of the lifter body which indexes with a groove and hole in the lifter plunger. Oil is then metered past the oil metering valve in the lifter, through the push-rods to the rocker arms.

When the lifter begins to ride up the cam lobe, the ball check is held against its seat in the plunger by the ball check spring which traps the oil in the base of the lifter body below the plunger. The plunger and lifter body then raise as a unit, pushing up the push-rod to open the valve. The force of the valve spring which is exerted on the plunger through

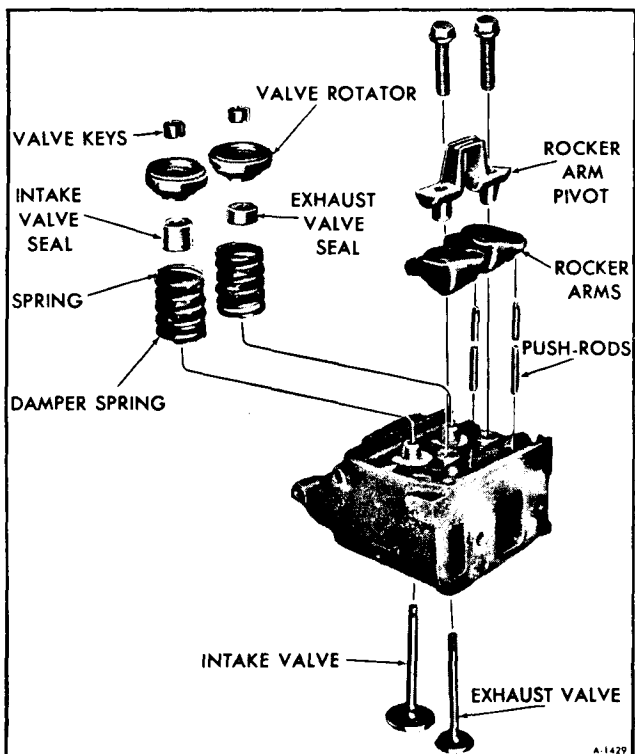

Figure 17-Cylinder Head-Exploded View

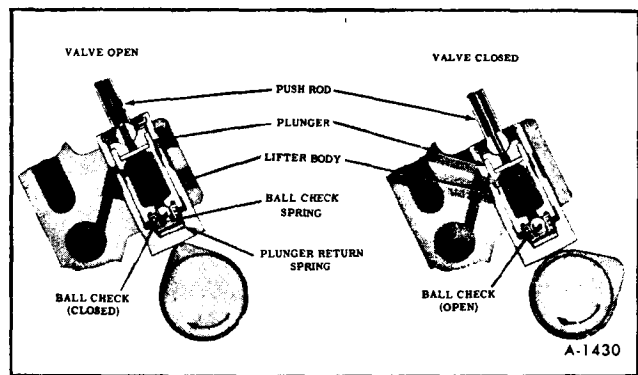

Figure 18-Valve Lifter Cutaway

the rocker arm and push-rod causes a slight amount of leakage between the plunger and lifter body. This "leak-down" allows a slow escape of trapped oil in the base of the lifter body. As the lifter rides down the other side of the cam lobe and reaches the base circle or "valve closed" position, the plunger spring quickly moves the plunger back (up) to its original position. This movement causes the ball check to open against the ball spring and oil from within the plunger is drawn into the base of the lifter. This restores the lifter to zero lash. See Figure 18.

### Valve Lifter Diagnosis

#### 1. Momentarily Noisy When Vehicle Is Started:

This condition is normal. Oil drains from the lifters which are holding the valves open when the engine is not running. It will take a few seconds for the lifter to fill after the engine is started.

#### 2. Intermittently Noisy on Idle Only, Disappearing When Engine Speed is Increased:

Intermittent clicking may be an indication of a flat or pitted ball, or it may be caused by dirt.

Correction: Clean the lifter and inspect. If ball is defective, replace lifter.

#### 3. Noisy At Slow Idle or With Hot Oil, Quiet With Cold Oil or As Engine Speed is Increased:

Insert a .015" feeler gauge between the rocker arm and valve stem. If noise momentarily disappears and then reappears after a few seconds with the feeler still inserted, it is an indication that the lifter leak-down rate is too fast.

Correction: The lifter must be replaced.

#### 4. Noisy at High Vehicle Speeds and Quiet at Low Speeds.

a. High oil level - Oil level above the "Full" mark allows crankshaft counterweights to churn the oil into foam. When foam is pumped into the lifters, they will become noisy since a solid column of oil is required for proper operation.

Correction: Drain oil until proper level is obtained. See Section O at the beginning of this manual.

b. Low oil level - Oil level below the "Add" mark allows the pump to pump air at high speeds which results in noisy lifters.

Correction: Fill until proper oil level is obtained. See Section O at the beginning of this manual.

5. Noisy at Idle Becoming Louder as Engine Speed is Increased to 1500 rpm.

a. This noise is not connected with lifter malfunction. It becomes most noticeable in the vehicle at 10 to 15 mph "L" range, or 30 to 35 mph "D" range and is best described as a hashy sound. At slow idle, it may be entirely gone or appear as a light ticking noise in one or more valves. It is caused by one or more of the following:

1. Badly worn or scuffed valve tip and rocker arm pad.
2. Excessive valve stem to guide clearance.
3. Excessive valve seat runout.
4. Off square valve spring.
5. Off square rocker arm pad.
6. Excessive valve face runout.
7. Valve spring damper clicking on rotator.

Correction: Remove valve covers and while listening with a stethoscope, locate noisy valves by increasing engine speed slightly above idle, about 1500 rpm. With gloved hand, push side-ways on valve spring. Noise will change, either becoming louder or disappearing completely. Some noise will be present in all valve locations. It is necessary to determine which are actually responsible for the noise.

a. Occasionally this noise can be eliminated by rotating the valve spring and valve. Crank engine until noisy valve is off its seat. Rotate spring. This will also rotate valve. Repeat until valve becomes quiet. If correction is obtained, check for an off square valve spring. If spring is off square more than 1/16" in free position, replace spring. See Figure 19.



Figure 19—Checking Valve Spring

b. Observe rocker arm pad for excessive wear or excessive off square. Replace as required. See Figure 20.

c. Check for excessive valve stem to guide clearance. If necessary, correct as required.

6. Valves Noisy Regardless of Engine Speed.

This condition can be caused by foreign particles or excessive valve lash.

Correction: a. With transmission in "park" and parking brake on, run the engine at a moderate speed.

If this method does not quiet the lifter, strike the rocker arm above the push-rod with a mallet while the engine is idling. This method of correction has proven successful for dislodging a foreign particle which is preventing the ball from seating properly.

b. Check for valve lash by turning engine so the piston in that cylinder is on top dead center of firing stroke. If valve lash is present, the push-rod can be freely moved up and down a certain amount with rocker arm held against valve.

Valve lash indicates one of the following:

1. Worn push-rod.
2. Worn rocker arm.

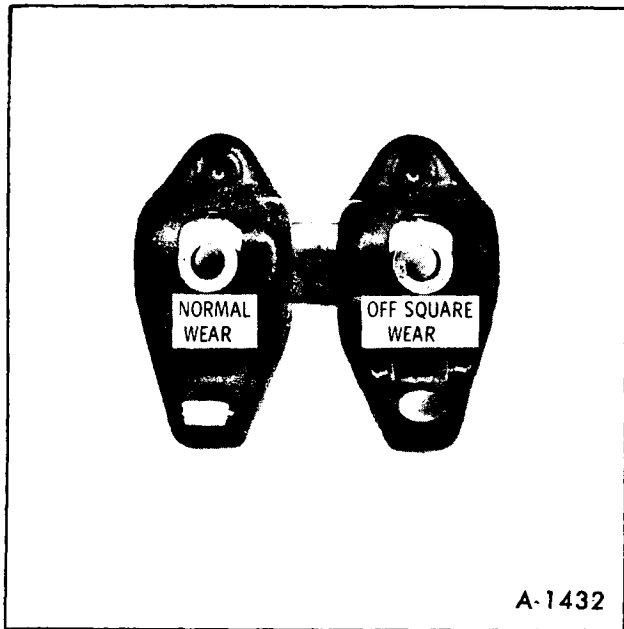

Figure 20-Rocker Arm Wear

3. Lifter plunger stuck in down position due to dirt or varnish.

4. Defective lifter.

Checking of the above four items:

1. Observe upper end of push-rod. Excessive wear of the spherical surface indicates one of the following conditions.

a. Improper hardness of the push-rod ball. The push-rod and rocker arm must be replaced.

b. Improper lubrication of the push-rod. The push-rod and rocker arm must be replaced. The oiling system to the push-rod should be checked.

2. If push-rod appears in good condition and has been properly lubricated, replace rocker arm and recheck valve lash.

3. If valve lash exists and push-rod and rocker arm are okay, trouble is in the lifter. Lifter should be replaced.

## REMOVAL

**NOTE:** Valve lifters and push-rods should be kept in order so they can be reinstalled in their original position. Some engines will have both standard and .010" oversize valve lifters, the

.010" oversize lifter is etched "O" on the side of the lifter. The cylinder block will also be marked if the oversize lifter is used.

1. Remove intake manifold and gasket. Refer to "Intake Manifold" earlier in this section.

2. Remove valve covers, rocker arm assemblies and push-rods. Refer to those areas earlier in this section.

3. If lifters are varnished, apply carburetor cleaning solution to lifter body. Allow five minutes for solution to remove varnish. Remove valve lifters.

**CAUTION:** *Carburetor cleaning solvent should be used in a well ventilated room. Avoid contact with skin and prolonged breathing of fumes.*

## DISASSEMBLY

1. Remove retainer ring with a small screwdriver.

2. Remove push-rod seat and oil metering valve.

3. Remove plunger and plunger spring. If plunger is stuck tight, allow lifter to soak in carburetor cleaning solvent for approximately five minutes, then remove.

4. Remove ball check retainer from plunger, then remove ball and spring.

## CLEANING AND INSPECTION

After lifters are disassembled, all parts should be cleaned in clean solvent. A small particle of foreign material under the ball check valve will cause malfunctioning of the lifter. Close inspection should be made for nicks, burrs or scoring of parts. If either the body or plunger is defective, replace with a new lifter assembly.

**NOTE:** Do not condemn valve lifters that have a slight gap or show evidence of leakage where the lifter foot is welded to the lifter body.

Whenever lifters are removed, check the lifter foot for abnormal wear as follows:

1. Place a straight edge across the lifter foot.

**NOTE:** Lifter foot must be clean and dry.

2. While holding the lifter at eye level check for light between the straight edge and lifter foot.

3. If light indicates a flat or concave surface of the lifter foot, the lifter should be replaced and the camshaft inspected for wear. Wear at the CENTER of the cam base circle is NORMAL. The camshaft should be replaced ONLY when wear is present across FULL WIDTH of cam base circle.

## ASSEMBLY

1. Assemble ball check, spring and retainer into plunger. See Figure 21. Make sure retainer flange is pressed tight against bottom of recess in plunger.

2. Install plunger spring over ball check retainer.

3. Hold plunger with spring up and insert into lifter body. Hold plunger vertically to prevent cocking spring.

4. Assemble oil metering valve and push rod seat and seat retaining ring in groove.

## INSTALLATION

1. Install lifters and push-rods into original position in cylinder block. See note under Removal.

2. Install baffle as shown in Figure 22. Install manifold gaskets and manifold. Refer to "Intake Manifold" earlier in this section.

3. Position rocker arms, pivots and bolts on cylinder head as shown in Figure 17.

4. Install valve covers. Refer to "Valve Cover" earlier in this section.

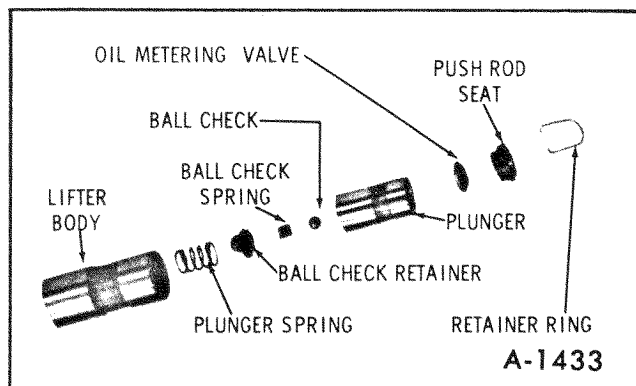

Figure 21-Valve Lifter-Exploded View

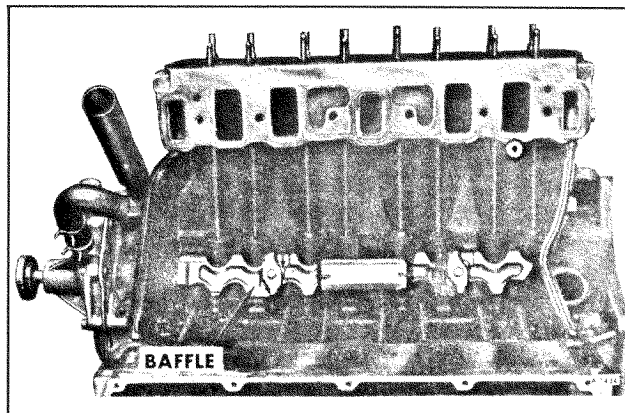

Figure 22-Baffle Installation

## CYLINDER HEAD AND GASKET

### REMOVAL

1. Drain radiator. Drain cock located at lower left side of radiator. By raising the rear wheels approximately 2-1/2 feet high, enough engine coolant will drain from the engine block to allow removal of the heads.

**NOTE:** To avoid overloading the front suspension raise front of the vehicle enough so front wheels are just off the ground.

2. Remove intake manifold. Refer to "Intake Manifold" earlier in this section.

3. Loosen exhaust pipe clamp at muffler. Remove exhaust manifold bolts and position exhaust manifold away from head.

4. Loosen or remove any accessory brackets which interfere with head removal.

5. Remove valve cover. Refer to "Valve Cover" earlier in this section.

6. Remove rocker arm bolts, pivots, rocker arms and push-rods as shown in Figure 17.

**NOTE:** Scribe pivots and keep rocker arms separated so they can be installed in their original locations.

7. Remove cylinder head bolts, then remove cylinder head.

**CAUTION:** Gasket surfaces on both the head and the block must be clean of any foreign matter and free of nicks or heavy scratches. The cylinder head bolt threads in the block and threads on cylinder head bolt must be cleaned. Dirt will affect bolt torque.

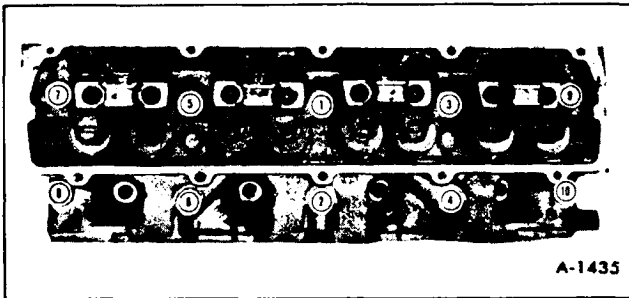

Figure 23—Cylinder Head Torque Sequence

## INSTALLATION

1. Use a new head gasket and coat both sides with part No. 1050026 sealer or equivalent. Install gasket with bead facing cylinder.

2. Dip cylinder head bolts in engine oil.

3. Install cylinder head and torque bolts to 60 ft. lbs. in sequence as shown in Figure 23. Then re-torque in sequence to 85 ft. lbs.

4. Install push rods, pivots, rocker arms and bolts. Torque rocker arm pivot bolts to 25 ft. lbs., tighten by alternating from side to side.

**NOTE:** Be sure to replace rocker arms and pivots to their original locations.

5. Install valve cover. Refer to "Valve Cover" earlier in this section.

6. Install intake manifold. Refer to "Intake Manifold" earlier in this section.

7. Install any accessory brackets that were removed previously.

8. Install exhaust manifold. Torque bolts to 25 ft. lbs. Bench tabs around bolt heads. Torque clamp on exhaust pipe at muffler to 20 ft. lbs.

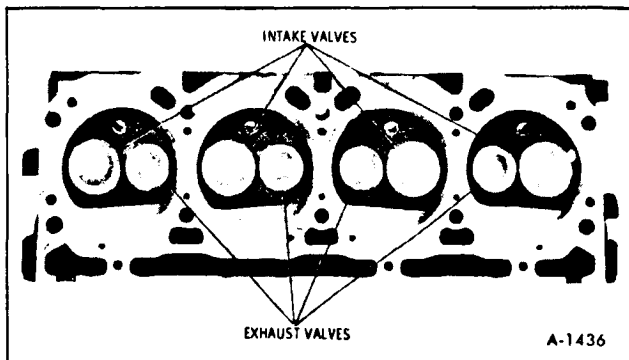

Figure 24—Valve Location

9. Add engine coolant.

10. Start engine and check for leaks.

## VALVES AND SPRINGS WITH HEAD REMOVED

### REMOVAL

1. Remove spark plugs.

2. Remove valve keys by compressing valve spring with a tool J-5892-1.

3. Remove valve spring rotators or retainers and springs.

4. Remove oil seals from valve stems.

5. Remove valves. Keep valves separated so they can be installed in their original locations. See Figure 24

### INSTALLATION

1. Install valves in their respective guides.

2. Install new oil seals over valve stem, using Tool J-24725. See Figure 25.

Position seals down as far as possible on valve stem. The seals will correctly position themselves when the engine is started.

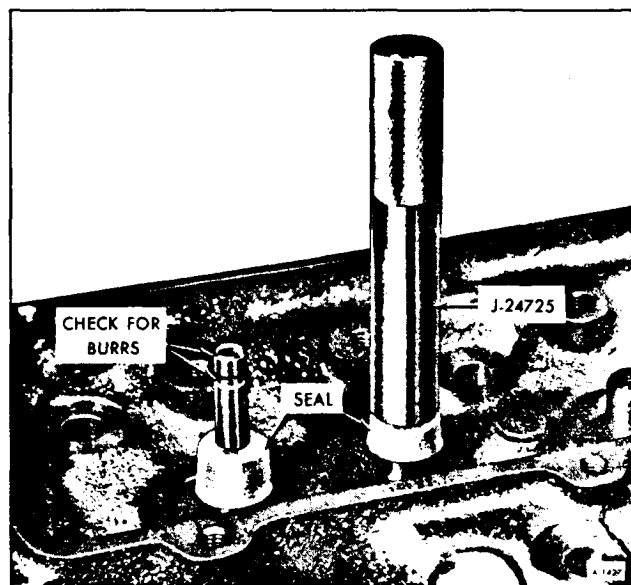

Figure 25—Valve Seal Installation



**NOTE:** Inspect seal for cracks after installation.

3. Position valve springs over valve stems.
4. Install valve rotators then compress springs with a tool J-5892-1 and install valve stem keys.
5. Check valve springs and keys to be sure they are properly seated.
6. Set spark plug gap. Lubricate plug threads with one drop of engine oil and re-install plugs. Torque to 35 ft. lbs.

### Reconditioning Valves

When reconditioning valves and valve seats, clean carbon from cylinder heads and valves using care not to gouge or scratch machined surfaces. A soft wire brush is suitable for this purpose. Whenever valves are replaced or new valves installed, the valve seats must be reconditioned.

Figure 26 shows the relation of valve angle and valve seat angle. Arc "A" should be  $44^\circ$  on the intake valve and  $30^\circ$  on the exhaust valve. Arc "B" should be  $45^\circ$  on the intake valve seat and  $31^\circ$  on the exhaust valve seat.

**NOTE:** Exhaust valve seats are hardened and must be ground, not cut.

If valve guide bores are worn excessively, they can be reamed oversize. This will require replacement of the valves with oversize valves (stems). The guide bores should be reamed before grinding the valve seats. Valve clearance in guide bore should be .001" to .004".

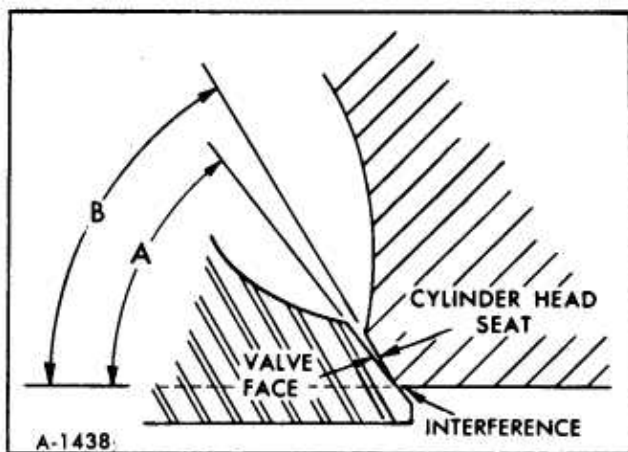

Figure 26—Relation of Valve and Seat Angles



Figure 27—Valve Guide Bore Marking

## VALVE GUIDE BORES

As previously stated, if the valve guide bores are worn excessively, they can be reamed oversize. The following reamers are available:

- .003" Oversize Valve Guide Reamer
- .005" Oversize Reamer
- .13" Oversize Valve Guide Reamer

If a standard valve guide bore is being reamed, use the .003" or .005" oversize reamer. For the .010" oversize valve guide bore, use the .013" oversize reamer. If too large a reamer is used and the spiraling is removed, it is probable that the valve will not receive the proper lubrication.

Occasionally a valve guide bore will be oversize as manufactured. These are marked on the inboard side of the cylinder heads on the machined surface just above the intake manifold surface (figure 27). These markings are visible without removing any parts other than the air cleaner assembly. Before removing the cylinder heads to perform service to either the valves or valve guide bores, the cylinder heads should be inspected to determine if these markings are present. If no markings are present, the guide bores are standard. If oversize markings are present, any valve replacement will require an oversize valve. If the oversize marking is present, only that particular bore would be oversize, not all bores in that cylinder head. Service valves are available in five different stem diameters: Standard, .003" oversize, .005" oversize, .010" oversize, and .013" oversize.



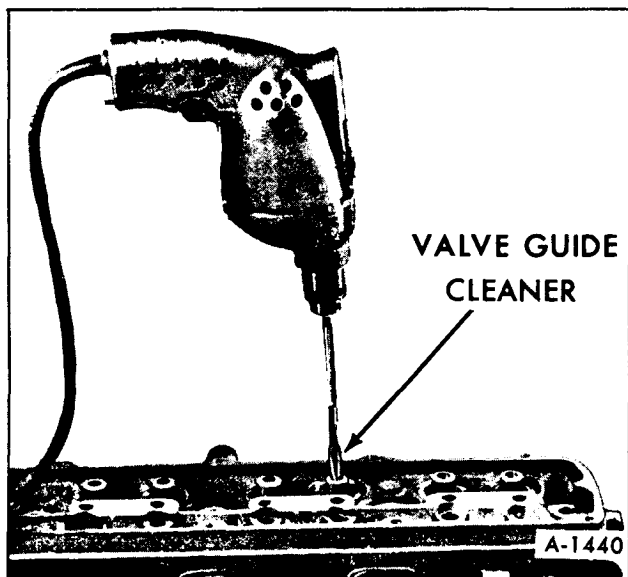

Figure 28—Cleaning Valve Guide Bores

### Reaming Procedure

Before attempting to ream the valve guide bores they should be cleaned using a tool as shown in Figure 28.

This procedure to ream valve guide bores using a reamer is shown in Figure 29. Use care to hold reamer straight in valve guide bore.

## REPLACING VALVE SPRING (HEAD ON ENGINE)

To replace a worn or broken valve spring without removing the cylinder head proceed as follows:

### REMOVAL

1. Remove valve covers. Refer to "Valve Cover" earlier in this section.
2. Remove rocker arm assemblies.
3. Remove spark plug and install Tool J-22794 into spark plug hole and attach to an air hose to hold the valve against its seat. (See figure 30).
4. Install Tool J-5892-1. See Figure 30. Compress the valve spring until valve keys are accessible, then remove keys, valve rotators and springs.

**NOTE:** If valve spring does not compress, tap tool with a hammer to break bind at rotator and keys.

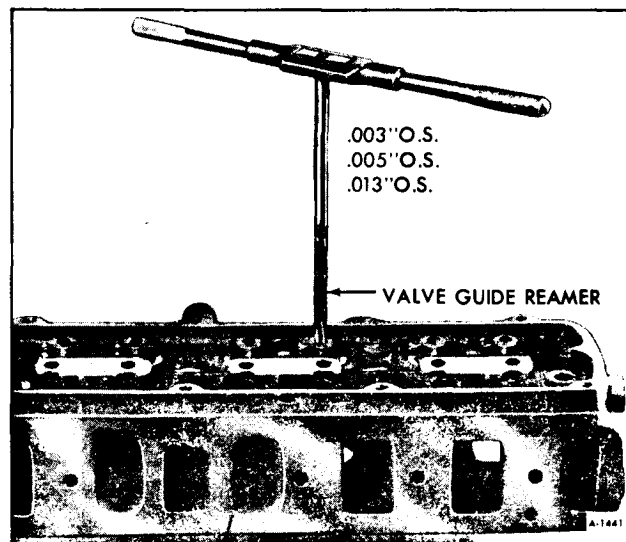

Figure 29—Reaming Valve Guide Bores

## CHECKING ROTATORS

The rotators cannot be disassembled and require replacement only when they fail to rotate the valve.

Rotator action can be checked by applying a daub of paint across the top of the body and down the collar. Run engine approximately 1500 rpm, there should appear to be motion between the body and collar, the body will appear to "walk" around the collar. Rotator action can be either clockwise or counterclockwise, sometimes on removal and reinstallation; the direction of rotation will change but this does not matter so long as it rotates.

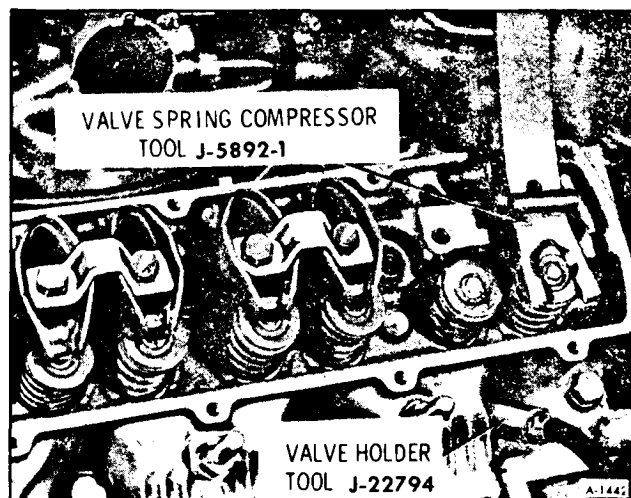

Figure 30—Removing Valve Spring

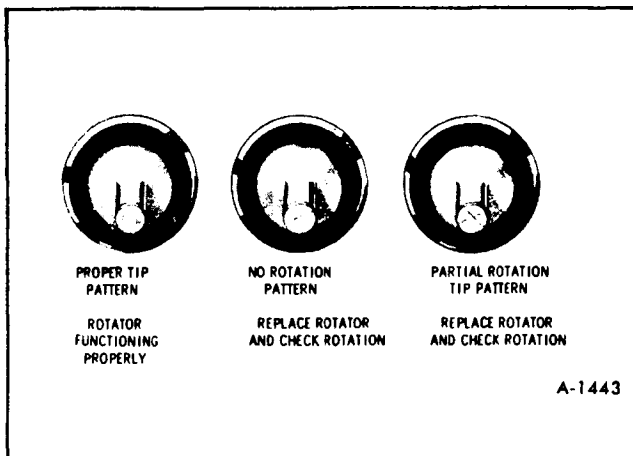

Figure 31-Valve Stem Wear

Anytime the valves are removed for service the tips should be inspected for improper pattern which could indicate valve rotator malfunction. See Figure 31.

## INSTALLATION

1. Install valve spring and rotator. Using Tool J-5892-1, compress the valve spring until the valve keys can be installed.
2. Remove tool No. J-22794 and install spark plugs. Torque 35 ft. lbs.
3. Install rocker arm assemblies.
4. Install valve covers. Refer to "Valve Cover" earlier in this section.

## OIL PAN

### REMOVAL

1. Remove transmission and final drive. Refer to "Engine Removal" later in this section.
2. Remove oil pan drain plug and drain oil.
3. Disconnect relay tie rod from the idler arm and the relay lever. Also disconnect steering shock absorber from crossmember bracket.
4. Remove L.H. lower venturi ring bracket.
5. Disconnect power steering pump.
6. Remove four (4) front support bolts and front

motor mount bolts. Position support forward. (See figure 6).

7. Remove flywheel.
8. Remove oil pan bolts.
9. Raise front of engine enough so the oil pan can be removed (approximately one inch).
10. Clean gasket surfaces on the engine block and the oil pan.

## INSTALLATION

1. Apply sealer 1050026 or equivalent to both sides of gaskets. Position all gaskets on engine block. See Figure 32.
2. Position oil pan on engine. Start all bolts and install until finger tight. Torque oil pan bolts to 10 ft. lbs.
3. Replace flywheel and torque bolts to 60 ft. lbs.
4. Lower engine to position. Install four (4) front support bolts and torque to 50 ft. lbs. See Figure 6.
5. Torque engine front support to 50 ft. lbs. (See figure 6).
6. Install power steering pump.
7. Install L.H. lower venturi ring bracket.
8. Connect relay tie rod and torque nuts to 50 ft. lbs., then insert cotter pin. Connect steering shock absorber to bracket at crossmember, torque nut to 40 ft. lbs.
9. Install oil pan drain plug. Torque to 30 ft. lbs.

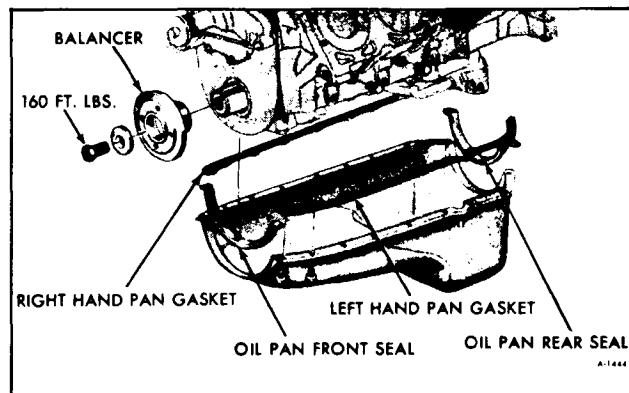

Figure 32-Oil Pan Assembly

10. Install transmission and final drive. Refer to "Engine Replacement" later in this section.
11. Lower vehicle.
12. Add engine oil. Refer to Section "O" for proper viscosity and quantity.
13. Start engine and check for leaks.

## OIL PUMP

### REMOVAL

1. Remove oil pan. Refer to "Oil Pan" earlier in this section.
2. Remove the oil pump to rear main bearing cap attaching bolts, then remove rear oil deflector, then remove pump and drive shaft extension.

### DISASSEMBLY (FIGURE 33)

1. Remove the oil pump drive shaft extension.

**NOTE:** Do not attempt to remove the washers from the drive shaft extension. The drive shaft extension and washers must be serviced as an assembly. See Figure 34.

2. Remove the cotter pin, spring and the pressure regulator valve.

**NOTE:** Position thumb over pressure regulator bore before removing cotter pin, as the spring is under pressure.

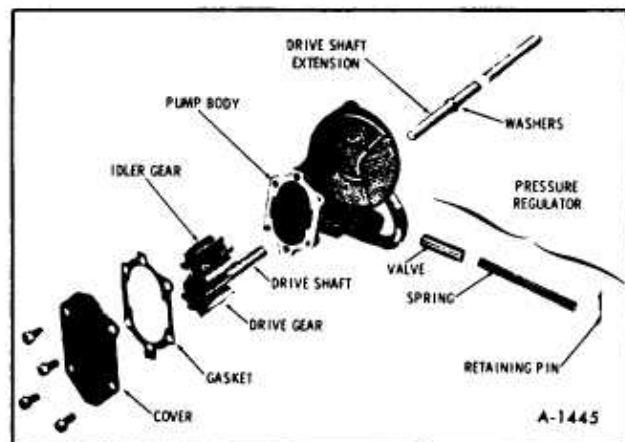

Figure 33—Oil Pump Exploded View

3. Remove the oil pump cover attaching screws and remove the oil pump cover and gasket.
4. Remove the drive gear and idler gear from the pump body.

### INSPECTION

Check the gears for scoring or other damage. If they are damaged, new gears should be installed. During assembly, the gear end clearance should be gauged. Proper end clearance is .0025" to .0065". Also check the pressure regulator valve, valve spring and bore for damage. Proper valve to bore clearance is .0025" to .0050".

### ASSEMBLY

1. Install the drive gear into the pump with the hex ID of the drive shaft toward the oil pump mounting pad, then install the idler gear.

2. Position a new gasket on the pump body and install the oil pump cover. Tighten the cover screws to 8 ft. lbs.

3. Position the pressure regulator valve into the pump cover, closed end first, then install the spring and retaining pin.

**NOTE:** When assembling the drive shaft extension to the drive shaft, the **END OF THE EXTENSION NEAREST THE WASHERS MUST BE INSERTED INTO THE DRIVE SHAFT.**

### INSTALLATION

1. Insert the drive shaft extension through the opening in the main bearing cap and block until the shaft mates into the distributor drive gear.

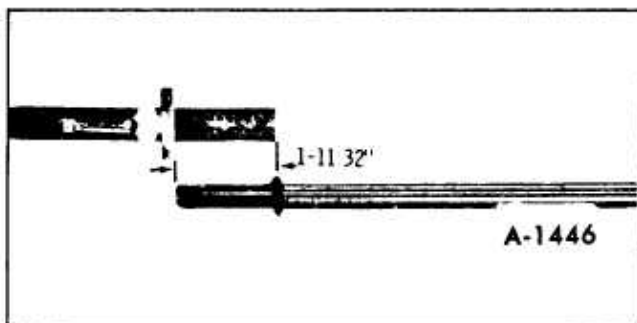

Figure 34—Oil Pump Shaft Extension

2. Position pump onto the rear main bearing cap, replace rear oil deflector and install attaching bolts. Torque bolts to 35 ft. lbs. See Figure 35.

3. Install the oil pan. Refer to "Oil Pan" installation earlier in this section.

## CONNECTING ROD AND PISTON ASSEMBLY

### REMOVAL

1. Remove intake manifold. Refer to "Intake Manifold" earlier in this section.

2. Remove head or heads, oil pan and oil pump. Refer to those areas earlier in this section.

**NOTE:** Stamp cylinder number on the machined surfaces of the bolt bosses of the connecting rod and cap for identification when reinstalling. If the pistons are to be removed from the connecting rod, mark cylinder number on piston with a silver pencil or quick drying paint for proper cylinder identification and cap to rod location. The right bank is numbered 2-4-6-8, left bank 1-3-5-7.

Examine the cylinder bore above ring travel. If ridge exists, remove ridge with ridge reamer before attempting to remove the piston and rod assembly.

3. Remove rod bearing cap and bearing.

4. Install guide hose over threads of rod bolts. This is to prevent damage to bearing journal and rod bolt threads. See Figure 36.

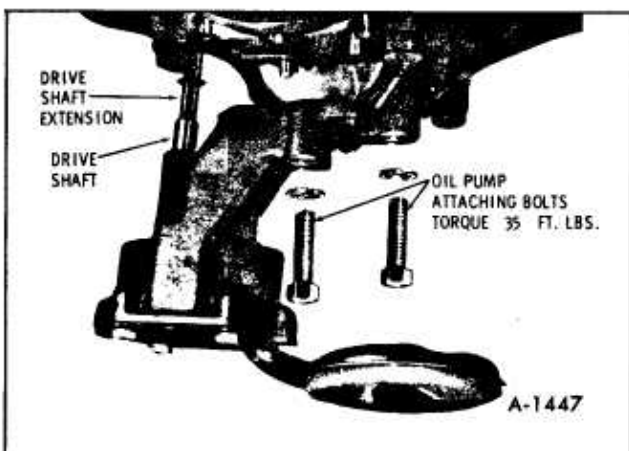

Figure 35—Oil Pump Installation

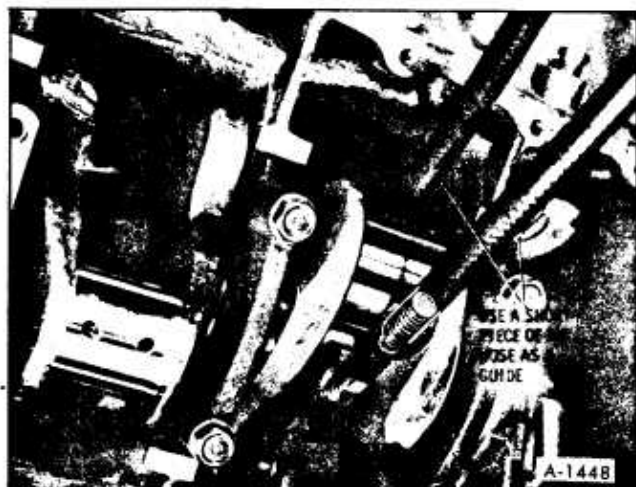

Figure 36—Connecting Rod Bolt Guide

5. Remove rod and piston assembly through the top of the cylinder bore.

6. Remove other rod and piston assemblies in the same manner.

## ROD BEARINGS

The connecting rod bearings are designed to have a slight projection above the rod and cap faces to insure a positive contact.

Connecting rod bearings can be replaced without removing the rod and piston assembly from the engine.

### REMOVAL

1. Remove oil pan. Refer to "Oil Pan" earlier in this section.

**NOTE:** It may be necessary to remove oil pump to provide access to rear connecting rod bearings.

2. With connecting rod journal at the bottom, stamp cylinder number on machined surfaces of connecting rod and cap for identification when reinstalling, then remove caps.

3. Inspect journals for roughness and wear. Slight roughness may be removed with a fine grit polishing cloth saturated with engine oil. Burrs may be removed with a fine oil stone by moving the stone on the journal circumference. Do not move the stone back and forth across the journal. If the journals are scored or ridged, the crankshaft must be replaced.

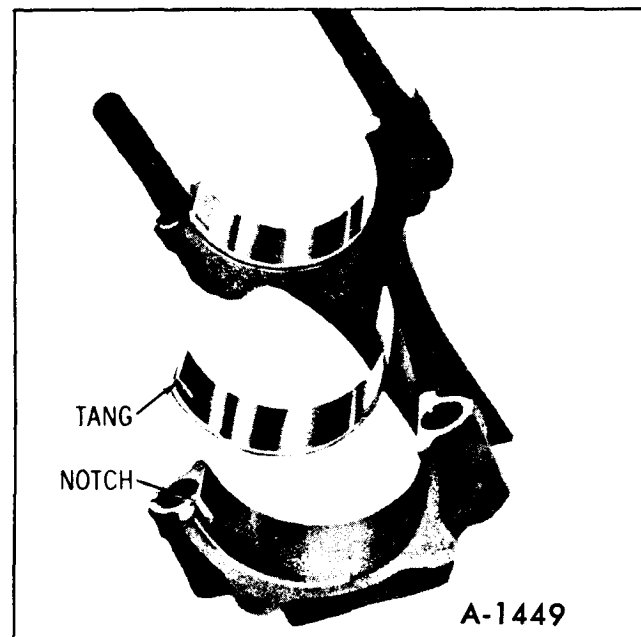

Figure 37—Bearing Tang and Notch

4. The connecting rod journals should be checked for out-of-round and correct size with a micrometer. Maximum out-of-round must not exceed .0015".

**NOTE:** Refer to "Engine Specifications" later in this section.

If Plastigauge is to be used:

5. Clean oil from journal bearing cap, connecting rod and outer and inner surface of bearing inserts.

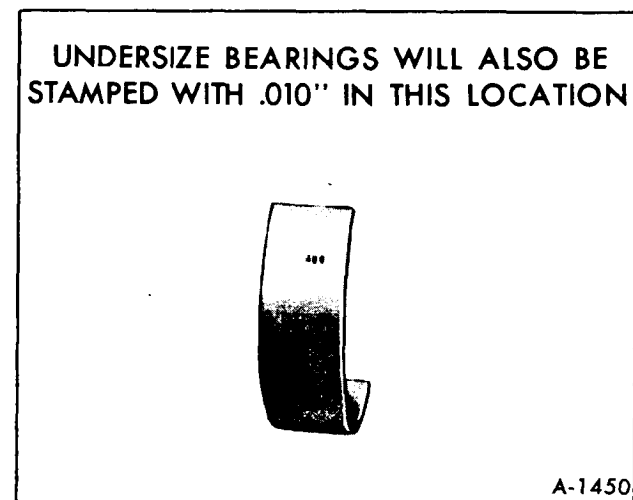

Figure 38—Bearing Identification

Position insert so that tang is properly aligned with notch in rod and cap. See Figure 37.

6. Place a piece of plastigauge in the center of lower bearing shell.

7. Reinstall bearing cap and torque to 42 ft. lbs.

8. Remove bearing cap and determine bearing clearances by comparing the width of the flattened plastigauge at its widest point with the graduation on the plastigauge container. The number within the graduation on the envelope indicates the clearance in thousandths of an inch. If this clearance is greater than .0035", replace the bearing and recheck clearance with plastigauge.

**NOTE:** Lubricate bearing with engine oil before installation. Repeat Steps 2 through 8 on remaining connecting rod bearings. All rods must be connected to their journals when rotating the crankshaft to prevent engine damage.

**NOTE:** Bearings are identified as shown in Figure 38.

9. Spread rods with screwdriver and measure the rod side clearance as shown in Figure 39. Clearance should be .006" to .020".

**NOTE:** If a rod is twisted or bent, a new rod must be installed. **NO ATTEMPT SHOULD BE MADE TO STRAIGHTEN CONNECTING RODS.**

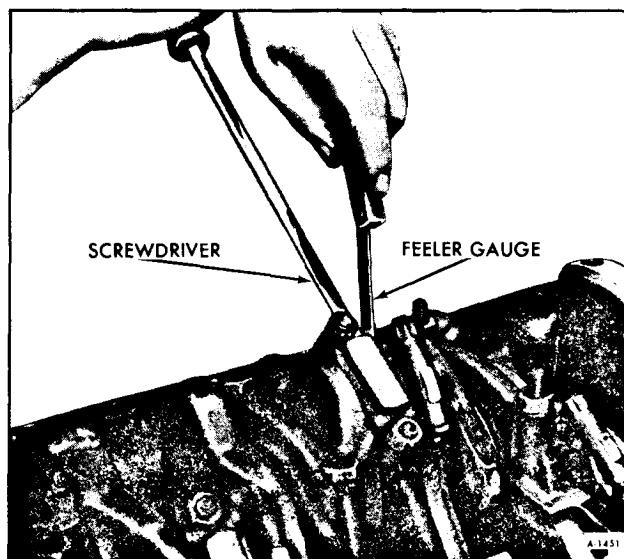

Figure 39—Connecting Rod Side Clearance

## PISTON

### MEASURING PISTON

**NOTE:** Refer to PISTON INFORMATION Chart. When replacing pistons, the original cylinder size is stamped with a code letter on the block near each cylinder on the cylinder head surface. See Figure 40.

When measuring piston for size or taper, measurement must be made on skirt 90° from piston pin hole (with the piston pin removed). See Figure 41.

When measuring taper, the largest reading must be at the bottom of the skirt. Allowable taper is .000" to .001".

The piston and cylinder bore must be free of oil and at the same temperature.

**NOTE:** In some engines, oversize pistons may be found. These pistons will be .010" oversize.

1. Place a strip of .0015" feeler gauge against the upper side of the bore, at 90° to the normal piston pin location. Attach a scale which measures in pounds to a feeler gauge. See Figure 42.

2. Insert piston upside down with pin and rings removed, into bore.

3. While holding the piston in the center of its normal travel, slowly pull the scale in a straight line and note the reading on the scale. The reading should

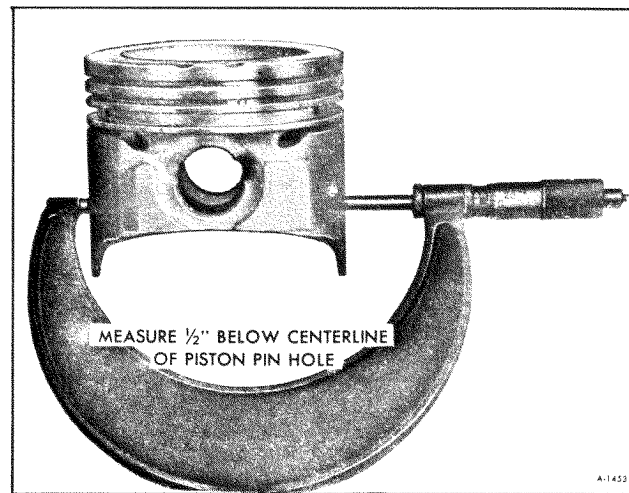

Figure 41—Measuring Piston

be between 3 to 12 pounds while pulling the feeler gauge out of the bore.

Each piston should be fitted to its individual cylinder and marked for that cylinder.

### CLEANING PISTON

Clean the pistons by scraping carbon off the top of the piston. Deposits in the ring grooves should be removed with a suitable ring groove cleaning tool. It is important that the ring grooves be completely free of deposits.

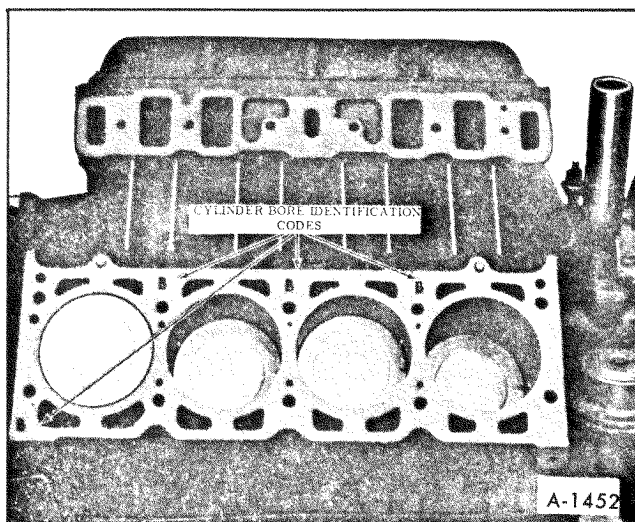

Figure 40—Cylinder Bore Marking

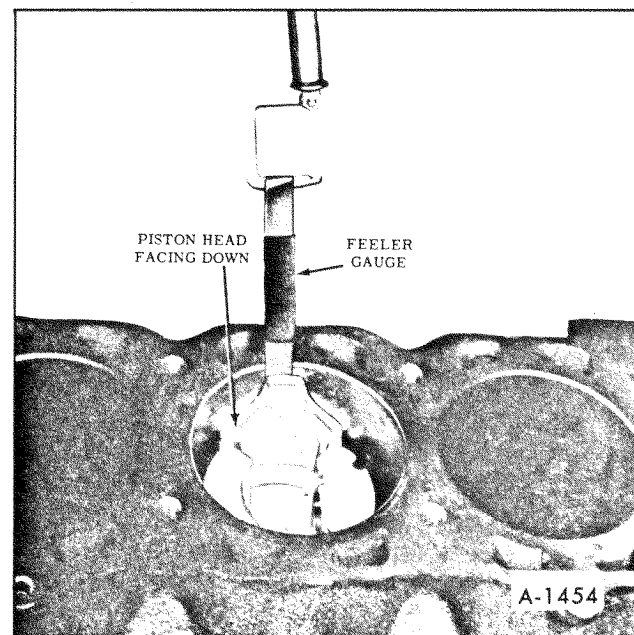

Figure 42—Checking Piston Clearance

## PISTON INFORMATION CHART

BORE DIAMETER	CYLINDER BORE SELECTION	BORE SIZES	PISTON SELECTION	PISTON SIZE	PISTON DIAMETER	PISTON TO CYL. BORE CLEARANCE	RING SIZE	
4.1250-4.1270 Std.	A	4.1250-4.1255	A	4.1240-4.1235	4.1255-4.1235 Std.	.001 to .002	Std.	
	B	4.1255-4.1260	B	4.1245-4.1240				
	C	4.1260-4.1265	C	4.1250-4.1245				
	D	4.1265-4.1270	D	4.1255-4.1250				
4.1350-4.1370 .010 O.S.	J	4.1350-4.1355	J	4.1340-4.1335	4.1355-4.1355 .010 O.S.		.001 to .002	.010" O.S.
	K	4.1355-4.1360	K	4.1345-4.1340				
	L	4.1360-4.1365	L	4.1350-4.1345				
	M	4.1365-4.1370	M	4.1355-4.1350				

### CHECKING CYLINDER BORE

**NOTE:** Refer to PISTON INFORMATION Chart.

Cylinder bore size can be measured with inside micrometers or a cylinder gauge. Maximum allowable taper of the cylinder bore is .001". The most wear will occur at the top of the ring travel.

Reconditioned cylinder bores should be held to not more than .001" out-of-round and .001" taper.

If the cylinder bores are smooth, the cylinder walls should not be deglazed. If the cylinder walls are scored the walls may have to be honed before installing new rings. It is important that reconditioned cylinder bores be thoroughly washed with a soap and water solution to remove all traces of abrasive material to eliminate premature wear.

### RINGS (FIGURE 43)

The pistons have three rings (two compression rings and one oil ring). The oil ring consists of two rails and an expander.

### RING TOLERANCES

When installing new rings, ring gap and side clearance should be checked as follows:

### PISTON RING AND RAIL GAP

Each ring and rail gap must be measured with the ring or rail positioned squarely and at the bottom of the ring-travel area of the bore. See Figure 44.

The gap measurement should be .013" to .023" for compression rings and .015" to .055" for oil rings.

### SIDE CLEARANCE

Each ring must be checked for side clearance in its respective piston groove by inserting a feeler gauge between the ring and its upper land. See Figure 45. The Piston grooves must be cleaned before checking ring for side clearance.

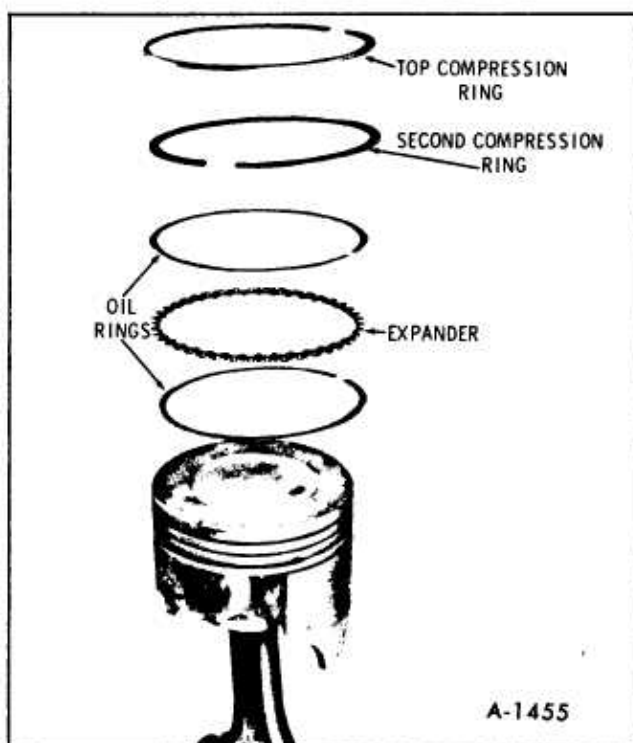

Figure 43-Piston Rings



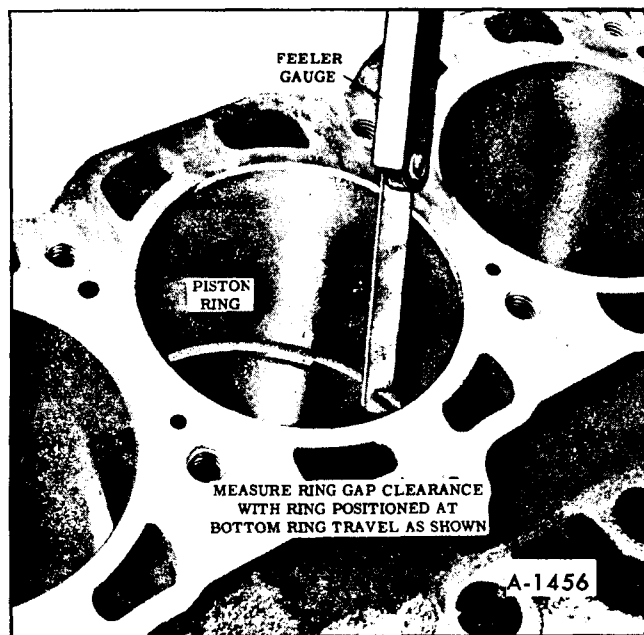

Figure 44—Measuring Piston Ring Gap

**NOTE:** To check oil ring side clearance, the oil rings must be installed on the piston.

Allowable side clearance is:	
Compression Rings	.002" to .004"
Oil Ring	.002" to .008"

## RING IDENTIFICATION AND INSTALLATION

For service ring specifications and detailed installation instructions, refer to the instructions furnished with the parts package.

## ROD AND PISTON ASSEMBLY INSTALLATION

1. Install connecting rod bolt guide hose over rod bolt threads. (See figure 36).

2. Apply engine oil to rings and piston, then install piston ring compressing tool on piston. See Figure 46.

3. Install assembly in its respective cylinder bore so notch cast in top of piston is towards the front of engine.

4. Lubricate the crankshaft journal with engine

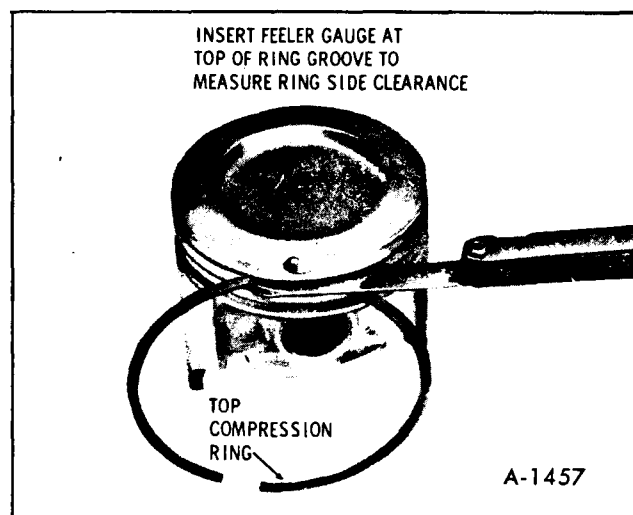

Figure 45—Piston Ring Side Clearance

oil and install connecting rod bearing and cap, with bearing index tang in rod and cap on same side.

**NOTE:** When more than one rod and piston assembly is being installed, the connecting rod cap attaching nuts should only be tightened enough to keep each rod in position until all have been installed. This will facilitate installation of remaining piston assemblies.

The clearance between the adjacent rods, when checked with a feeler gauge on each crankpin, should be from .006" to .020". Refer to Figure 39.

5. Torque rod bolt nuts to 42 ft. lbs.

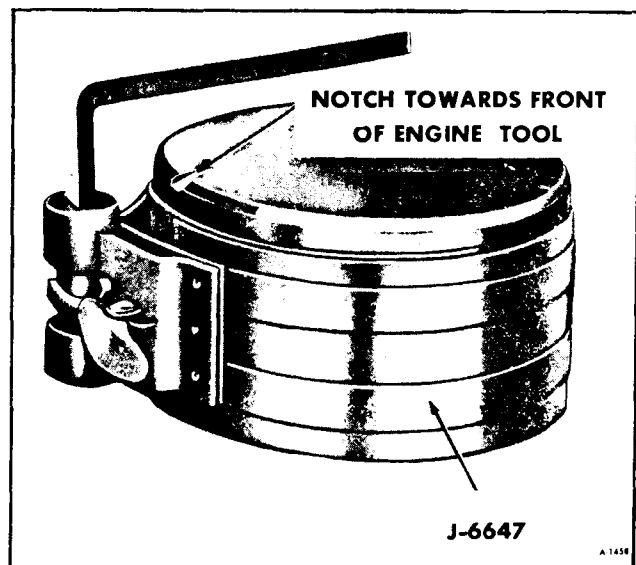

Figure 46—Piston Ring Compressor



## PISTON PINS

The correct piston pin fit in the piston is .0003" to .0005" loose. If the pin to piston clearance is to the high limit (.0005"), the pin can be inserted in the piston with very little hand pressure and will fall through the piston by its own weight. If the clearance is .0003", the pin will not fall through. It is important that the piston pin hole be clean and free of oil when checking pin fit. The pin is a press fit in the connecting rod.

Whenever the replacement of a piston pin is necessary, use the following procedure.

### REMOVAL

1. Place piston on piston pin remover with letter "F" on piston facing up.
2. Press out piston pin.

### INSTALLATION

1. Place piston on piston pin installer with letter "F" on piston facing up.
2. Coat piston pin and hole with engine oil. Press in piston pin. Piston pin to connecting rod fit is .0008" to .0018" interference fit.

## CRANKSHAFT PULLEY

### REMOVAL

1. Loosen all belts enough so they may be slipped off crankshaft pulley.
2. Hoist motor home.
3. Remove four (4) pulley bolts and pulley.

### INSTALLATION

1. Install pulley and four (4) bolts. Torque bolts to 10 ft. lbs.
2. Install belts. Refer to "Belt Tension" next in this section.

## BELT TENSION

**NOTE:** All belt tension checks must be taken midway on the greatest span of that belt.

1. Using belt tension checking gauge J-23600 or other suitable gauge check power steering belt (vehicles equipped with automotive air conditioning **MUST** have power steering belt checked and adjusted if necessary first). A used power steering belt should be adjusted to 70-80 lbs. A new power steering belt should be adjusted to 110-140 lbs.

2. Check and adjust as required the generator and air conditioning compressor (if equipped) belts. Belt tension should be the same as above.

## HARMONIC BALANCER

### REMOVAL

1. Remove engine cover.
2. Loosen all accessory drive belts.
3. Raise vehicle.
4. Remove venturi ring seal retainer strap. Push seal forward and over shroud.
5. Slip belts off crankshaft pulley.
6. Remove four (4) crankshaft pulley bolts and remove pulley.
7. Remove harmonic balancer hub bolt and washer.
8. Using balancer puller, remove balancer as shown in Figure 47.

**CAUTION:** *Use of any other type puller such as a universal claw type which pulls on the outside of the hub can destroy the balancer. The outside ring of the balancer is bonded in rubber to the hub; by pulling on the outside, rather than the hub, it is possible to break the bond. The timing mark is on the outside ring of the balancer; if the bond between the hub and the outside ring is broken, the outside ring could slip which would change the location of the timing mark.*

If it is suspected that the bond has been broken and the timing mark changed, it can be visually checked as shown in Figure 48. Keyway should be approximately 16° from timing slot. In addition there are

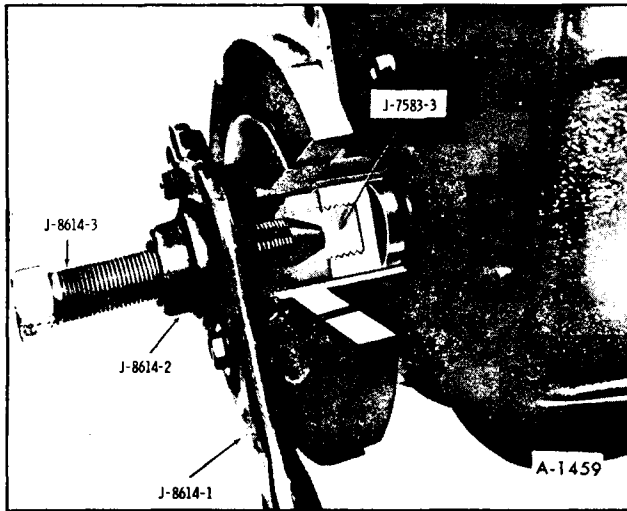

Figure 47—Removing Harmonic Balancer

chisel aligning marks between the weight and hub. These marks should be aligned.

## INSTALLATION

1. Apply sealer 1050026 or equivalent, to inside diameter of pulley hub and to crankshaft key to prevent possible oil leakage. Coat outside area of crankshaft pulley hub which enters seal with Special Seal Lubricant No. 1050169, or equivalent.

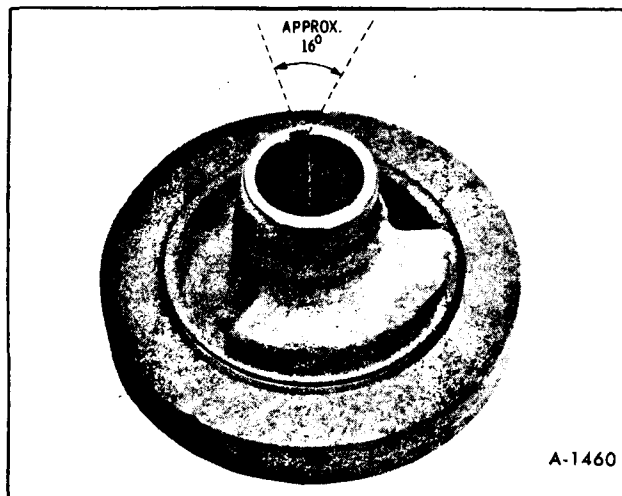

Figure 48—Harmonic Balancer

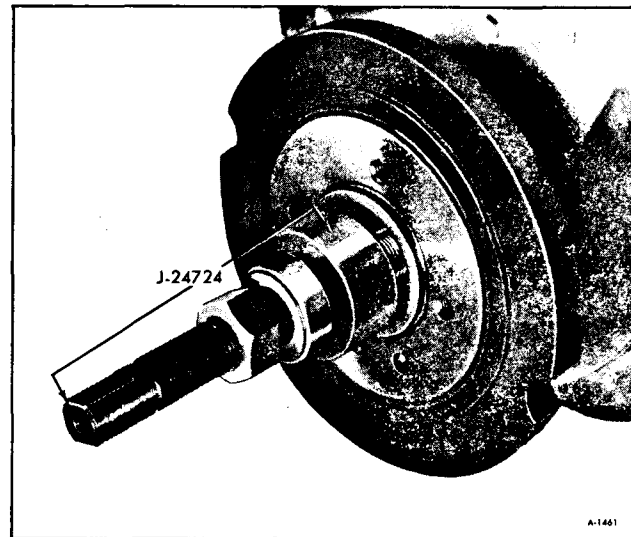

Figure 49—Installing Harmonic Balancer

2. Install harmonic balancer on crankshaft (Figure 49). Use tool J-24724.

**NOTE:** Balancer to crankshaft fit is .001" tight to .0007" loose.

3. Install washer and bolt. Torque bolt to 160 ft. lbs.

4. Install crankshaft pulley and torque four (4) bolts to 10 ft. lbs.

5. Position belts over pulley.

6. Reposition venturi ring seal and install seal retainer strap.

7. Lower vehicle.

8. Tension drive belts. Refer to "Belt Tension" earlier in this section.

9. Install engine cover.

## FRONT COVER OIL SEAL

### REMOVAL (FRONT COVER INSTALLED)

1. Raise motor home.

2. Loosen belts so they may be slipped off crankshaft pulley.

3. Remove crankshaft pulley and harmonic balancer. Refer to "Crankshaft Pulley" and "Harmonic Balancer" earlier in this section.

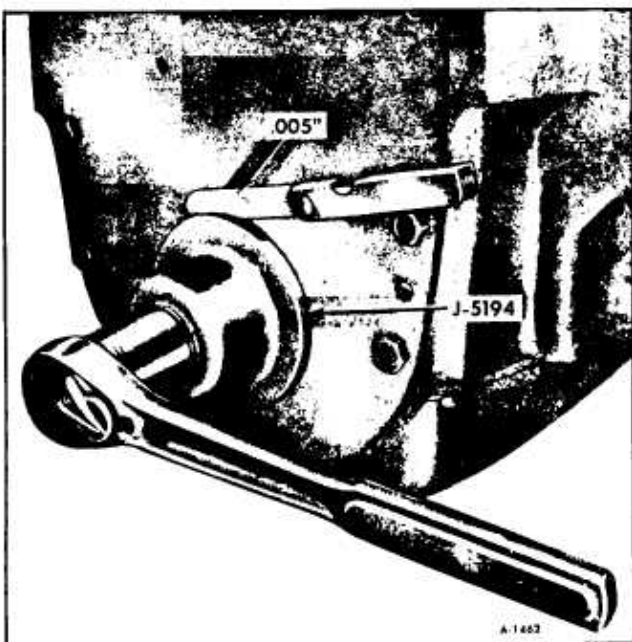

Figure 50—Front Cover Oil Seal Installation

4. Pry seal out of cover from the front with a large screwdriver, being careful not to damage the surface on the crankshaft.

## INSTALLATION

1. Apply 1050026 sealer or equivalent to outside diameter of seal.

2. Using Tool J-5154, install oil seal as shown in Figure 50. Tighten until .005" feeler gauge will fit between front cover and tool.

3. Install crankshaft pulley and harmonic balancer. Refer to "Crankshaft Pulley" and "Harmonic Balancer" earlier in this section.

4. Install belts. Refer to "Belt Tension" earlier in this section.

5. Lower motor home.

## FRONT COVER

### REMOVAL

1. Raise motor home.

2. Drain cooling system. Disconnect radiator hoses, heater hoses, and by-pass hose from the water pump and radiator.

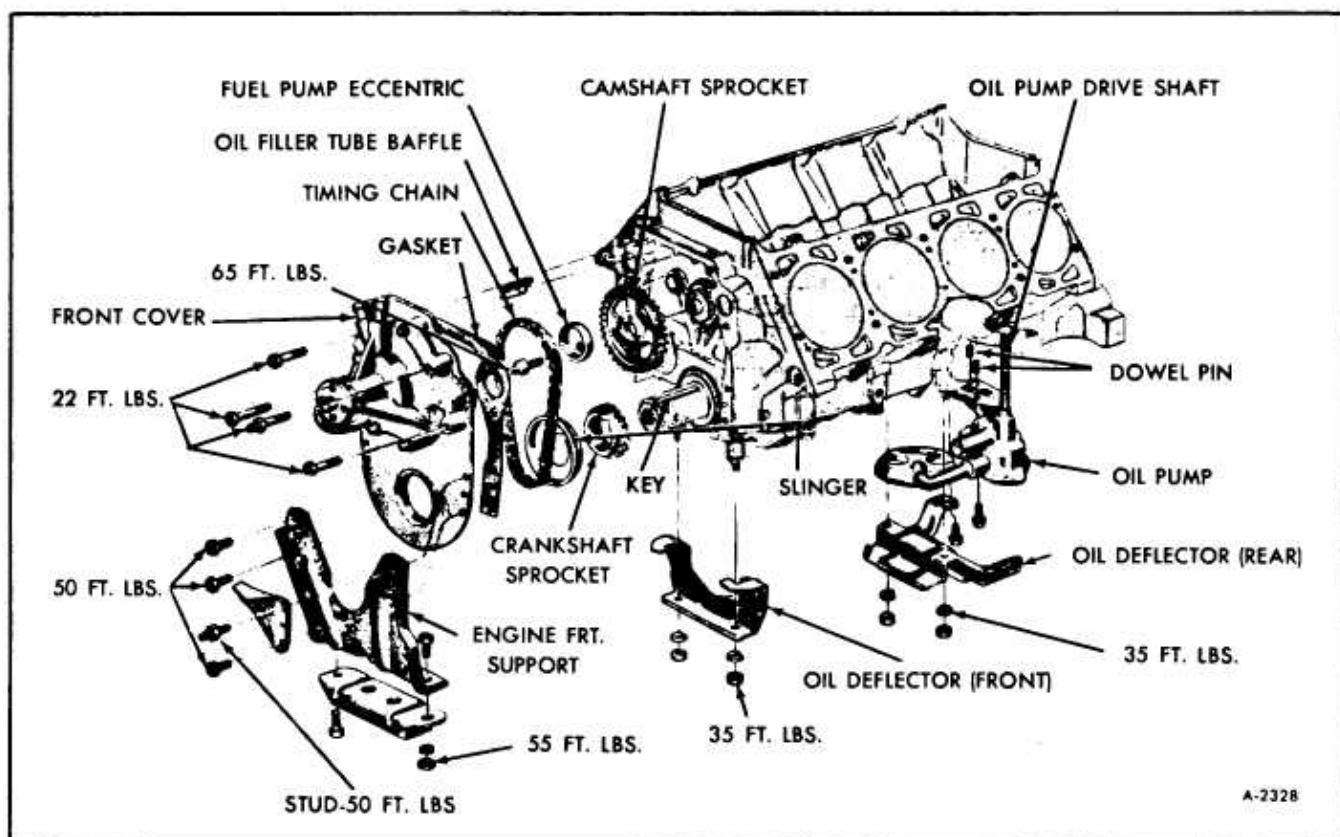

Figure 51—Engine Front Cover Exploded View

3. Drain oil.
4. Remove shroud seal retainer strap.
5. Roll shroud to venturi ring seal over shroud.
6. Remove fan clutch assembly.
7. Remove venturi ring.
8. Remove engine drive belts.
9. Remove crankshaft pulley and harmonic balancer. See "Crankshaft Pulley" and "Harmonic Balancer" earlier in this section.
10. Remove oil pan. Refer to "Oil Pan" earlier in this section.
11. Remove front cover to block attaching bolts and remove front cover, timing indicator and water pump assembly (See figure 51).

## INSTALLATION

1. Install new cover gasket. Apply 1050026 or equivalent, sealer to gasket around water holes and place gasket on block.
2. Install front cover, timing indicator and water pump assembly. Apply engine oil to bolts and torque bolts as shown in Figure 52.
3. Apply lubricant 1050169 or equivalent, on pulley hub seal surface.
4. Install oil pan. See "Oil Pan" earlier in this section.
5. Install harmonic balancer and crankshaft pulley. Refer to "Harmonic Balancer" and "Crankshaft Pulley" earlier in this section.
6. Install belts. Refer to "Belt Tension" earlier in this section.
7. Install venturi ring and torque nuts to 20 ft. lbs.
8. Install fan clutch assembly and torque nuts to 15 ft. lbs.
9. Roll shroud-to-venturi ring seal off of shroud and install shroud seal retainer strap.
10. Connect radiator hoses, heater hoses and bypass hose to water pump and radiator.

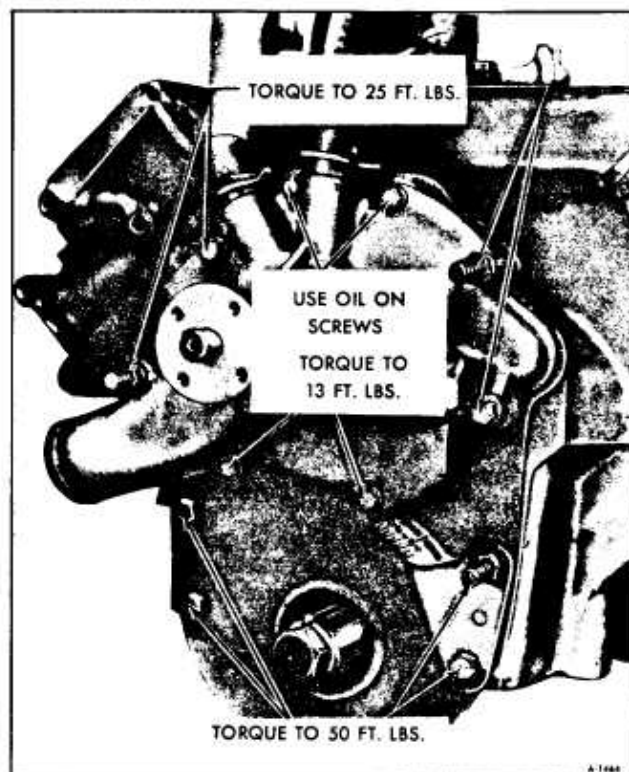

Figure 52—Engine Front Cover Bolts

11. Replace oil drain plug and shut radiator drain cock.
12. Lower motor home.
13. Fill radiator and crankcase. Start engine and check for leaks.

## TIMING CHAIN AND GEARS

### REMOVAL

1. Raise motor home.
2. Remove front cover. See "Front Cover" earlier in this section.
3. Remove fuel pump eccentric.
4. Remove oil slinger, camshaft and timing chain.
5. Remove key then crankshaft gear.

**NOTE:** Gear to crankshaft fit tolerances may be such that a puller is necessary. (See figure 53).

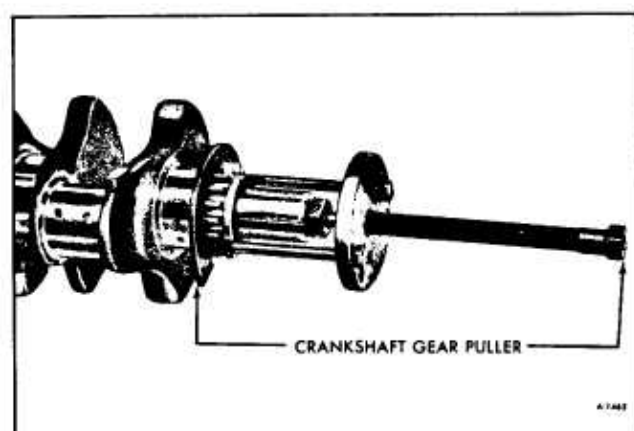

Figure 53—Crankshaft Gear Removal

**CAUTION:** Remove crankshaft key, if possible before using puller; if not, align puller so that it does not overlap end of key when using puller, keyway is machined only part way in crankshaft gear and breakage would occur.

## INSTALLATION

1. Install camshaft gear crankshaft gear and timing chain together, and then align timing marks as shown in Figure 54.

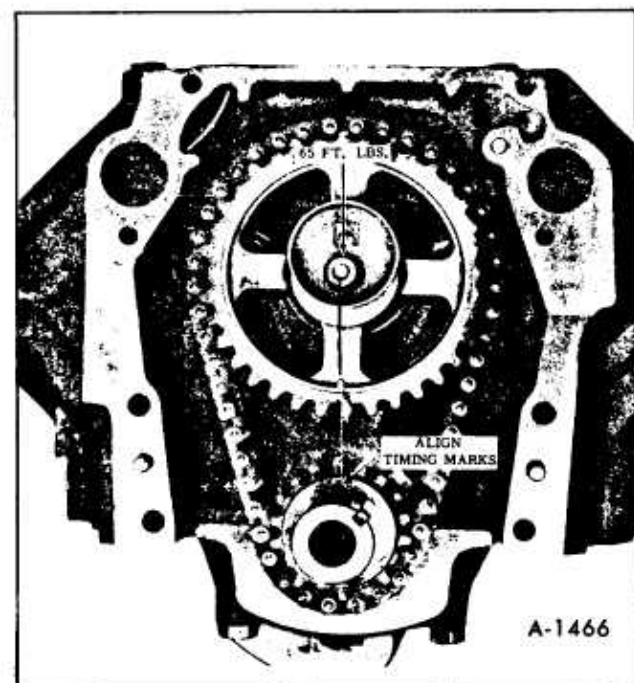

Figure 54—Timing Gear Position

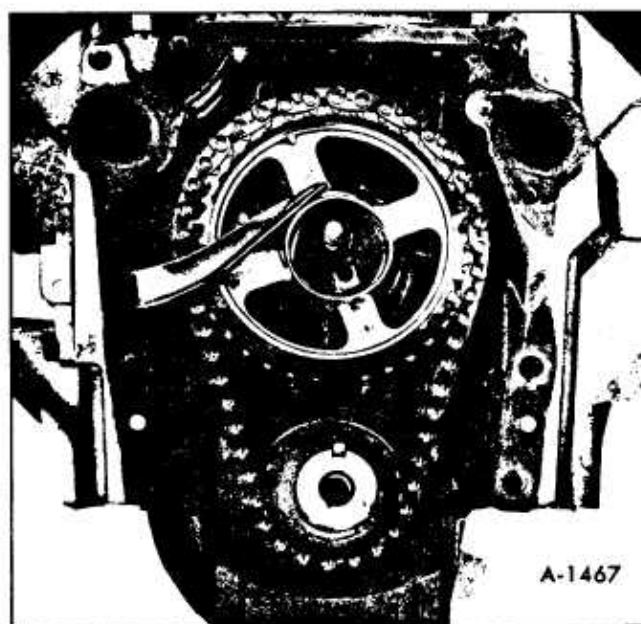

Figure 55—Fuel Pump Eccentric

2. Install fuel pump eccentric with flat side rearward. See Figure 55. Torque bolt to 65 ft. lbs.

3. Drive crankshaft gear key in with a brass hammer until it bottoms.

4. Install oil slinger.

5. Install front cover. See "Front Cover" earlier in this section.

6. Lower motor home.

## CHECKING VALVE TIMING WITHOUT REMOVING FRONT COVER

1. Remove distributor cap, right valve cover, No. 4 cylinder intake and exhaust rocker arms and pivot.

2. Ground coil wire to engine.

3. Turn ignition switch on. Crank engine until rotor is in line with No. 4 spark plug wire position. No. 4 piston will be approximately at the top of the cylinder.

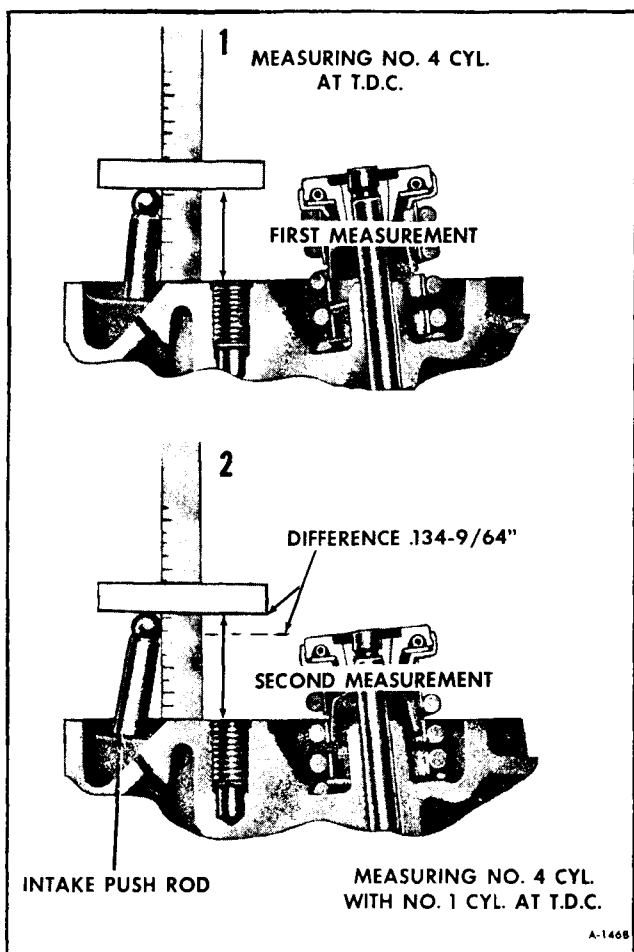

Figure 56—Checking Valve Timing

4. Measure from pivot boss on head surface to top of No. 4 intake push-rod. Record measurement. See Figure 56.

5. Slowly turn engine 1-1/2 revolutions until rotor approaches No. 1 spark plug wire position. Continue to turn engine until timing mark on crank pulley is aligned with O on indicator. This is top dead center of No. 1 piston.

6. Again measure from pivot boss surface to top of No. 4 cylinder intake push-rod. See Figure 56.

7. Measurement should increase over the first measurement as shown in Figure 56.

8. If measurement increase is not within 1/32" of that shown on chart, camshaft is advanced or retarded.

## ENGINE REPLACEMENT

The engine assembly may be removed with or without the transmission and final drive attached.

**NOTE:** It is recommended to remove the transmission and final drive from the vehicle before the engine.

In some situations repair to the engine (ie. piston replacement, oil pan gasket replacement, oil pump repair etc.) requires removal of the engine oil pan. If this is the case, refer to "Oil Pan" earlier in this section.

Refer to steps 1 through 20 for removal of transmission and final drive with engine remaining in vehicle.

Refer to steps 21 through 46 for removal of engine after the transmission and final drive have been removed.

**WARNING:** A VEHICLE OF THIS SIZE AND WEIGHT COMBINED WITH THE WEIGHT AND BULKINESS OF THE ENGINE AND/OR TRANSMISSION AND FINAL DRIVE DURING REMOVAL PRESENTS A POTENTIALLY DANGEROUS SITUATION TO PERSONNEL. ENGINE, TRANSMISSION AND FINAL DRIVE REMOVAL EITHER AS A UNIT OR SEPARATE COMPONENTS SHOULD BE PERFORMED WHILE USING A "TWIN POST" HOIST.

## REMOVAL

1. Disconnect negative (-) battery cables from both the automotive and living area batteries.

**NOTE:** Drain radiator before raising vehicle.



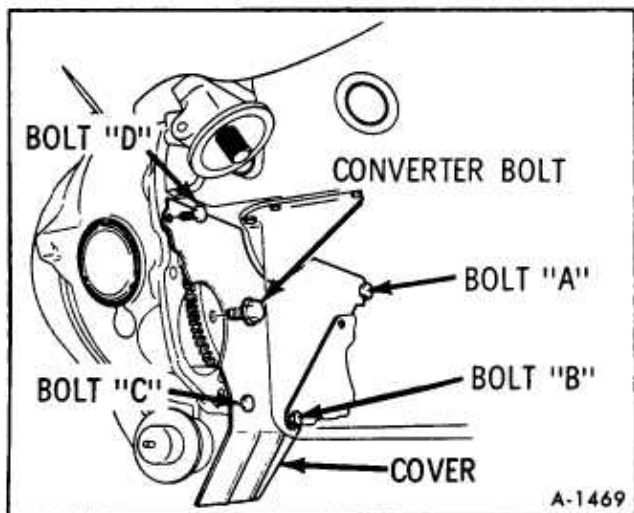

Figure 57—Flywheel Cover Removal

2. Remove engine cover, remove air cleaner, disconnect coil bracket and position engine removal Tool No. J-24603 to the engine. Adjust lift mechanism until all slack is removed from the cable. (See figure 5).

3. Raise motor home. See WARNING at the beginning of "Engine Replacement".

4. Disconnect wires from starter solenoid.

5. Remove starter motor.

6. Referring to Figure 57, remove flywheel cover bolts "B", "C" and "D". Loosen bolt "A" and pivot cover out of the upper L.H. bolt "A" slot.

7. Disconnect transmission shift linkage and speedometer cable from transmission and position to one side.

8. Disconnect transmission fluid cooler lines, detent solenoid wire and modulator tube from the transmission. Position all to the side.

9. Disconnect R.H. drive axle from the final drive output shaft. (Refer to Section 3B). Move drive axle rearward.

10. Remove lower R.H. venturi ring bracket.

11. Remove output shaft bracket from engine and remove R.H. output shaft assembly from final drive.

12. Disconnect L.H. drive axle from flange at the flange and reposition axle rearward and remove the flange.

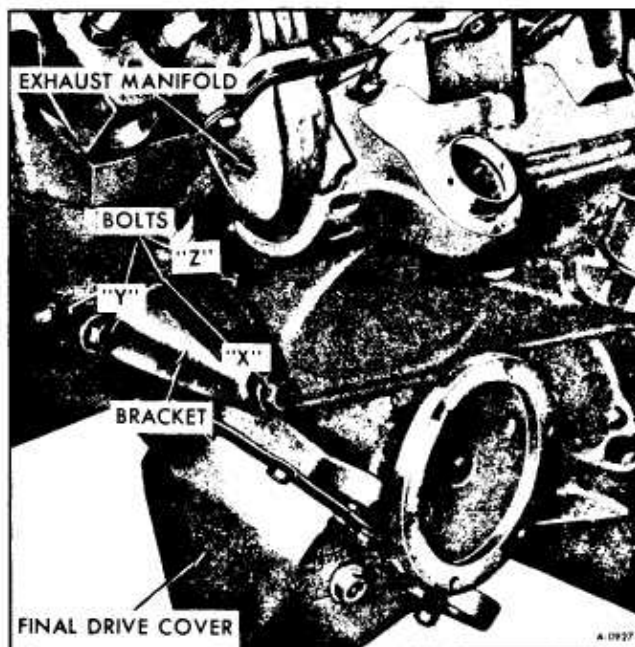

Figure 58—Disconnecting Final Drive From Engine

13. Remove bolt "Z". (See figure 58).

14. Remove three (3) bolts that secure the converter to the flywheel.

NOTE: Rotate flywheel to gain access (Refer to figure 57).

15. Remove three (3) transmission to support bracket bolts (Figure 7).

16. Remove support bracket to crossmember bolts.

17. Position transmission jack under transmission as shown in Figure 59.



Figure 59—Transmission Jack Installation

18. Remove six (6) bolts that attach the flywheel housing to the engine.

19. Slide transmission rearward.

**NOTE:** Reposition transmission support bracket upward as required to obtain clearance between transmission and floor.

20. Remove transmission and final drive.

21. Lower vehicle.

22. Remove engine oil dipstick.

23. Disconnect vacuum lines to the brake booster and heater controls from the intake manifold. Disconnect the vacuum line to the carbon canister from the front of the carburetor.

24. Disconnect throttle linkage (See figure 11).

25. Disconnect coil bracket from engine and position on top of intake manifold. Disconnect wire from the negative coil terminal.

26. Disconnect heater hoses.

27. Disconnect wire from brake combination valve.

28. Disconnect engine harness.

29. Remove engine oil filler upper tube.

30. Remove engine oil dipstick tube.

31. Disconnect upper radiator hose from engine.

32. Disconnect air conditioning compressor (if equipped) from bracket and with wire support it up and out of the way.

**NOTE:** Freon lines do not have to be disconnected.

33. Remove generator.

34. Remove both upper venturi ring brackets.

35. Raise vehicle.

36. Disconnect both R.H. and L.H. exhaust pipes at exhaust manifolds.

37. Disconnect engine oil cooler tubes from tube to hose union.

38. Disconnect fuel line from fuel pump.

39. Remove fan and clutch assembly.

40. Remove lower L.H. venturi ring bracket.

41. Remove venturi ring retainer strap. Remove venturi ring and radiator shroud.

42. Disconnect lower radiator hose.

43. Disconnect power steering hoses from the power steering pump.

44. Remove engine front mounting bolts.

45. Remove hub cap from L.H. hub. Remove cotter pin and axle nut. Tap lightly on outboard end of L.H. axle until splines are free. Remove L.H. drive assembly.

46. Raise engine assembly using engine removing tool J-24603.

47. Gradually remove engine assembly by alternately raising, tilting and lowering the engine assembly. Use care when supporting engine on dolly to prevent damage to oil pan.

## INSTALLATION

1. Using tool J-24603 as shown in Figure 5, raise engine assembly adjusting and tilting until engine front mount lines up so bolts may be installed. Install nuts finger tight.

2. Install L.H. drive axle into knuckle and torque axle nut to 110 ft. lbs. Advance nut to next castellation if necessary and install cotter pin.

**NOTE:** Do not allow drive axle to hang unsupported. Use a piece of wire to support drive axle.

3. Raise transmission and final drive using the transmission jack. Position transmission support bracket while raising the transmission.

4. Position transmission and install six (6) bolts that attach flywheel housing to engine torque bolts to 25 ft. lbs.

5. Position transmission support bracket and referring to Figure 7 torque bolts "A", "B" and "C" to 55 ft. lbs. Torque bolts "D" and "E" to 55 ft. lbs.

6. Install three (3) converter to flywheel bolts. Torque to 30 ft. lbs.

**NOTE:** Rotate flywheel to gain access. Refer to Figure 57.



7. Referring to Figure 58, install bolt "Z" and torque to 105 ft. lbs.
8. Properly position L.H. drive axle and torque NEW attaching bolts to 65 ft. lbs.
9. Install R.H. output shaft into final drive and attach support bolts to engine.
 

**IMPORTANT:** When attaching the right hand output shaft to the engine bracket, do not let the shaft hang. Assemble bracket bolts loosely, and by moving the flange end of the shaft up and down, and back and forth, find the center location. Hold the shaft in this position and then torque the bolts to 55 ft. lbs. on support.
10. Install lower R.H. venturi ring bracket. Torque nut on engine stud to 45 ft. lbs. Torque nut at venturi ring attachment to 20 ft. lbs.
11. Position R.H. drive axle and torque NEW attaching bolts to 65 ft. lbs.
12. Connect transmission cooler lines and tighten fittings to 20 foot-pounds and then connect detent solenoid wire and modulator tube.
13. Connect transmission shift linkage and speedometer cable.
14. Referring to Figure 57, install flywheel cover and tighten bolts "A", "B", "C" and "D" to 5 ft. lbs. torque.
15. Install starter and torque bolts to 30 ft. lbs. Connect wires to starter.
16. Tighten engine front mounting nuts to 50 ft. lbs. torque.
17. Connect power steering lines to the power steering pump.
18. Install fan shroud and torque bolts to 15 ft. lbs.
19. Install engine fan and clutch assembly. Torque nuts to 15 ft. lbs.
20. Install L.H. lower venturi ring bracket. Torque nuts to 20 ft. lbs.
21. Install venturi ring. Make sure seal overlaps the venturi ring.
22. Secure venturi ring to brackets by installing nuts and bolts finger tight. Install shroud seal retainer strap.
23. Connect lower radiator hose. Torque clamp to 17 in. lbs.
24. Connect fuel line to fuel pump.
25. Connect engine oil cooler lines.
26. Connect R.H. and L.H. exhaust pipes. Tighten pipe to exhaust manifold bolts until they bottom on spacer.
27. Lower vehicle and remove engine removal tool J-24603.
28. Install both upper venturi ring brackets. Torque nuts to 25 ft. lbs.
29. Install generator. See Figure 9 for torque values. Refer to "Belt Tension" earlier in this section.
30. Install air conditioning compressor. See Figure 10 for torque values. Refer to "Belt Tension" earlier in this section.
31. Connect upper radiator hose to engine. Torque clamp to 17 in. lbs.
32. Install engine oil dipstick tube.
33. Install engine oil filler upper tube.
34. Connect engine harness.
35. Connect wire to the brake combination valve.
36. Connect heater hoses.
37. Connect coil bracket to engine. Connect wire to negative coil terminal.
38. Connect throttle linkage.
39. Connect vacuum lines to the brake booster and heater controls to the intake manifold. Connect the vacuum line from the carbon canister to the front of the carburetor.
40. Add engine oil and transmission fluid, as required. Add engine coolant. Refer to "Engine Cooling" later in this manual. Refer to SECTION 7 for details on "Checking and Adding Transmission Fluid".
41. Connect battery negative(-) ground cables.
42. Check transmission shift linkage. Refer to SECTION 7 under "Linkage Adjustment".
43. Shut engine off. After several minutes check engine oil level.

# OUT OF VEHICLE SERVICE OPERATIONS

## CAMSHAFT

### REMOVAL

1. Remove engine. Refer to "Engine Replacement" earlier in this section.
2. Remove oil pan. Refer to "Oil Pan" earlier in this section.
3. Remove crankshaft pulley and harmonic balancer. Refer to "Crankshaft Pulley" and "Harmonic Balancer" earlier in this section.
4. Remove front cover. Refer to "Front Cover" earlier in this section.
5. Remove valve covers. Refer to "Valve Covers" earlier in this section.
6. Remove spark plug cables and distributor cap intact.
7. Remove intake manifold. Refer to "Intake Manifold" earlier in this section.
8. Remove rocker arms, push rods and valve lifters. Refer to those items earlier in this section for removal.

**NOTE:** Parts position should be noted so they will be installed in their original location.

9. Remove bolt securing fuel pump eccentric, remove eccentric, camshaft gear, oil slinger and timing chain. Refer to "Timing Chain and Gears" in this section.
10. Remove camshaft by carefully sliding it out the front of the engine.

**NOTE:** Do not force shaft as damage can occur to camshaft bearings.

### INSTALLATION

1. Coat camshaft and bearings liberally with Part No. 1051396 or equivalent before installing.

2. Slide camshaft into block.

**NOTE:** Do not force shaft as damage may occur to camshaft bearings.

3. Install gears, timing chain, eccentric and oil slinger. Refer to "Timing Chain and Gears" earlier in this section.

4. Install valve lifters, push rods and rocker arms. Refer to "Rocker Arm Assemblies" earlier in this section.

5. Install intake manifold. Refer to "Intake Manifold" earlier in this section. Install belts and adjust. Refer to "Belt Tension" as described earlier in this section.

6. Install distributor as described in SECTION 6Y of this manual.

7. Install valve covers. Connect spark plug cables.

8. Install front cover. Refer to "Front Cover" earlier in this section.

9. Install crankshaft pulley and harmonic balancer. Refer to "Harmonic Balancer" and "Crankshaft Pulley" earlier in this section.

10. Install oil pan. Refer to "Oil Pan" as described earlier in this section.

11. Install engine. Refer to "Engine Replacement" earlier in this section.

## CAMSHAFT BEARINGS

The camshaft bearings must be replaced in complete sets. All bearings must be removed before any can be installed. No. 1 bearing must be removed first, then No. 2, then 3, 4, and 5. When installing the bearings, No. 5 must be installed first, then, 4, 3, 2 and 1.

### REMOVAL

1. Remove camshaft as described in "Camshaft" earlier in this section.

2. Using a cam bearing remover set drive out camshaft bearings starting with No. 1.

3. When removing No. 5 drive out rear cup plug, located behind No. 5 camshaft bearing. See Figure 60.

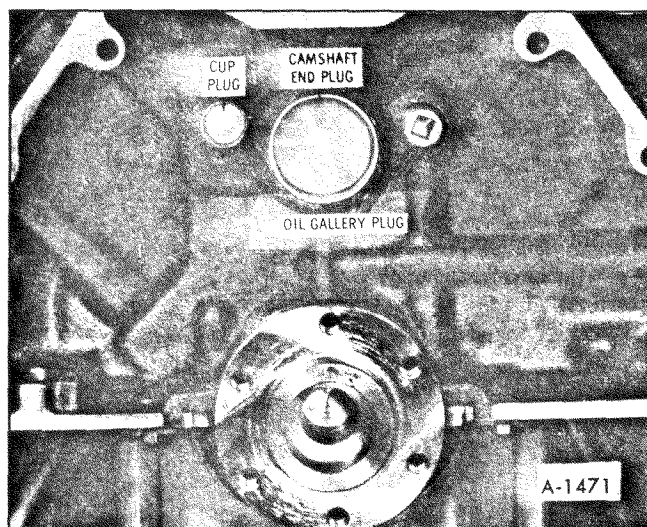

Figure 60—Camshaft and Oil Galley Plug

## INSTALLATION

1. Install new cup plug in rear of No. 5 bearing bore and seal with a permanent type sealer.

**NOTE:** To aid aligning bearings with oil passages, place each bearing in the front bore with tapered edge toward block and align the oil hole in the bearing with the center of the oil slot in the bore. Mark top of bearing. When installing the bearings the mark will act as a guide.

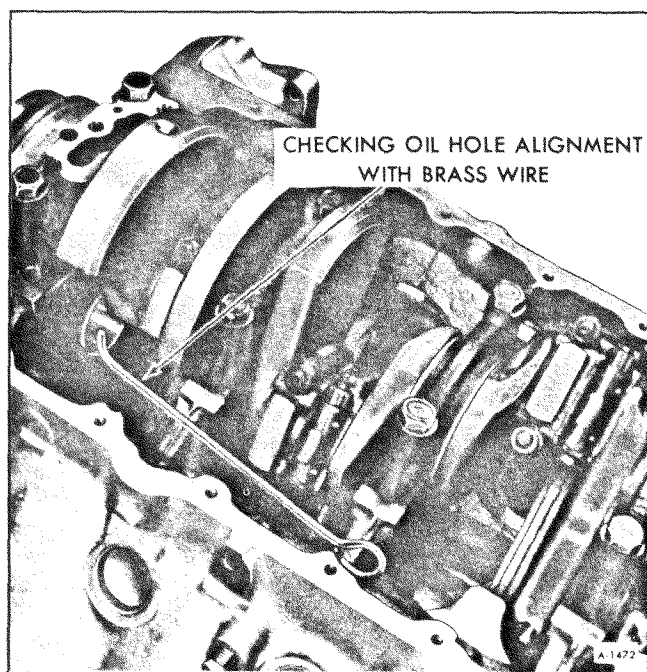

Figure 61—Checking Oil Hole Alignment

2. Drive No. 5 camshaft bearing into place and check oil hole alignment as shown in Figure 61.

3. Install remaining bearing checking for proper alignment of oil holes. Wire must enter hole or the bearing will not receive sufficient lubrication.

## CRANKSHAFT

### REMOVAL

1. With engine on stand and oil pan, oil pump and front cover removed, rotate crankshaft to the position where the connecting rod nuts are most accessible. Figure 62 shows No. 3 and No. 4 rods in the fully extended position.

2. Remove main bearing caps.

3. Remove connecting rod caps and install thread protectors.

4. Note position of keyway in crankshaft so it can be installed in the same position.

5. Lift crankshaft out of block. Rods will pivot to the center of the engine when the crankshaft is removed.

Do not allow pistons to move in their bore during or after crankshaft removal.

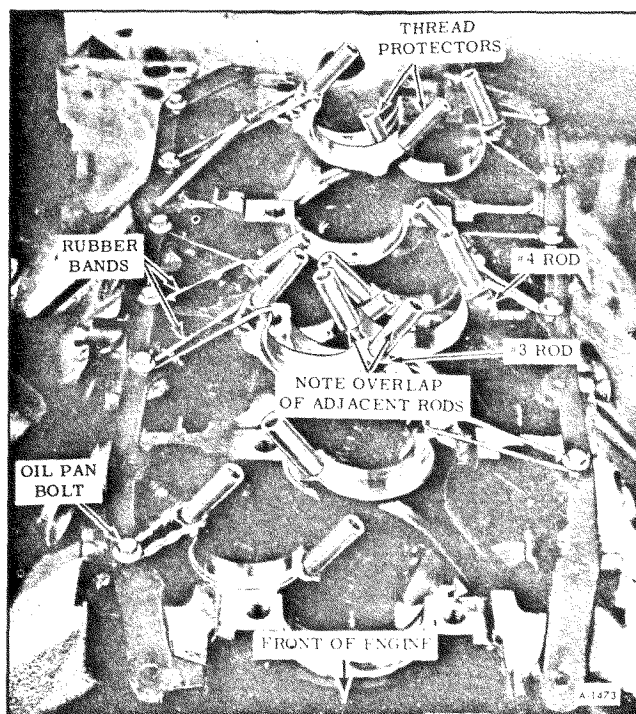

Figure 62—Crankshaft Removal

## INSTALLATION

1. Install sufficient oil pan bolts in pan rails to align rods with rubber bands as shown in Figure 62.

Align rods so that the inner thread protectors of adjacent rods overlap approximately one inch as shown. Alignment can be adjusted by increasing tension on rubber bands with additional turns around the pan bolts or thread protectors.

2. Position upper half of main bearings in block and lubricate with engine oil.

3. Install a new rear main bearing seal.

4. After oil passages in crankshaft have been checked for being open and shaft is clean, place shaft in block. Lubricate thrust flanges of the center bearing with 1050169 Lubricant or equivalent. Install caps with lower half of bearing lubricated with engine oil. Lubricate cap bolts with No. 1050125 or equivalent, and install, but do not tighten.

5. With a block of wood (figure 63) bump shaft in each direction to align thrust flanges of center main bearing.

**NOTE:** After bumping shaft in each direction, wedge the shaft to the front and hold it while torquing No. 3 cap bolts.

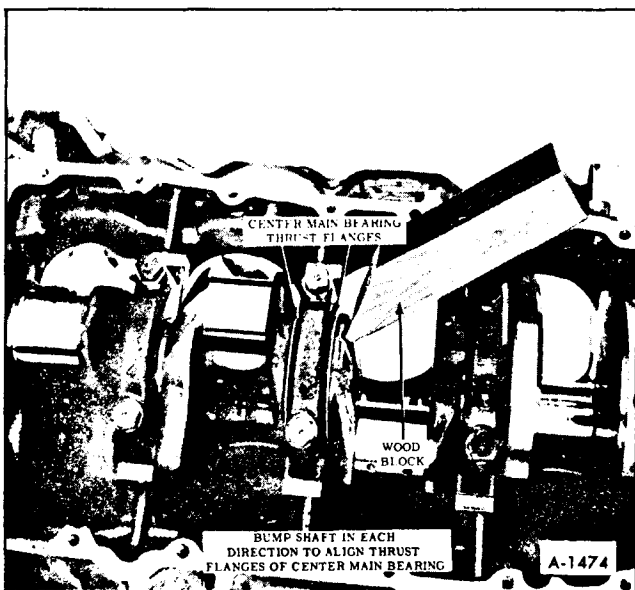

Figure 63—Aligning Center Main Bearing Flanges

6. Remove rubber bands, thread protectors and oil pan bolts.

7. Install main bearing caps and torque bolts to 120 ft. lbs.

8. Reassemble engine.

## MAIN BEARINGS

Main bearing clearance must not exceed .0035" on all bearings. The .0035" clearance is permissible only if the engine is disassembled for other than a bearing noise condition. If bearings are noisy or if a visual inspection indicates defective bearings, new bearings must be installed within the specifications outlined under "Main Bearings".

Bearings which fall within the .0035" specifications should not be rejected if the bearings show a normal wear pattern or slight radial grooves, unless it has been established to be defective.

## CHECKING BEARING CLEARANCES

1. If not already removed, remove oil pan. Refer to "Oil Pan" earlier in this section.

2. Remove bearing cap and wipe oil from crankshaft journal and outer and inner surfaces of bearing shell.

3. Place a piece of plastigauge in the center of bearing.

4. Use a floor jack or other means to hold crankshaft against upper bearing shell. This is necessary to obtain accurate clearance readings when using plastigauge.

5. Reinstall bearing cap and bearing. Place Lubricant No. 1050125 or equivalent on cap bolts and install.

Torque to 120 ft. lbs. cap bolts.

5. Remove bearing cap and determine bearing clearance by comparing the width of the flattened plastigauge at its widest point with graduation on the plastigauge container. The number within the graduation on the envelope indicates the clearance in thousandths of an inch. (figure 64) If this clearance is greater than .0035" **REPLACE BOTH BEARING SHELLS AS A SET.** Recheck clearance after replacing shells.

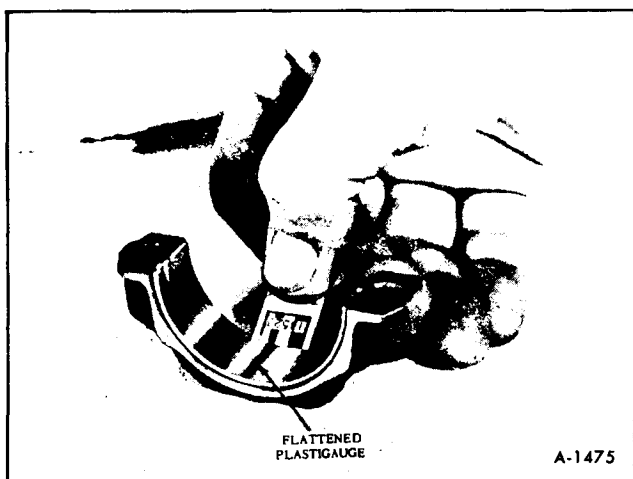

Figure 64—Checking Bearing Clearance

**NOTE:** Main bearing end thrust clearance should be .004" to .008" as checked with a dial indicator.

## MAIN BEARING REPLACEMENT

Main bearing clearance must be corrected by the use of selective upper and lower shells. **UNDER NO CIRCUMSTANCES** should the use of shims behind the shells, to compensate for wear, be attempted.

**NOTE:** The upper and lower shells must be installed in pairs (figure 65). Sizes of the bearings are located on the tang (figure 66). It is possible to have more than one bearing size in the same engine.

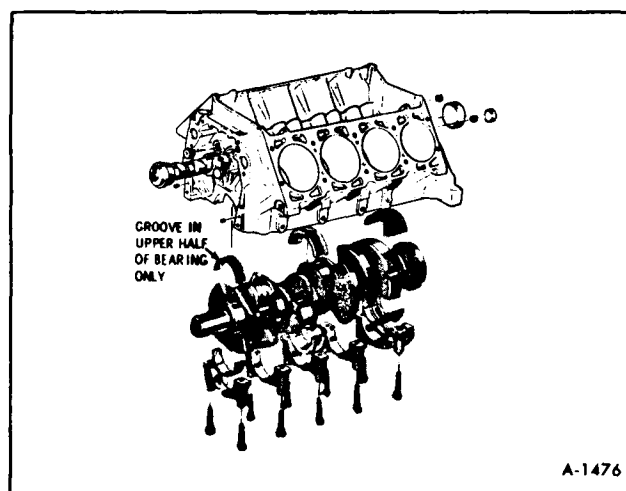

Figure 65—Crankshaft Exploded View

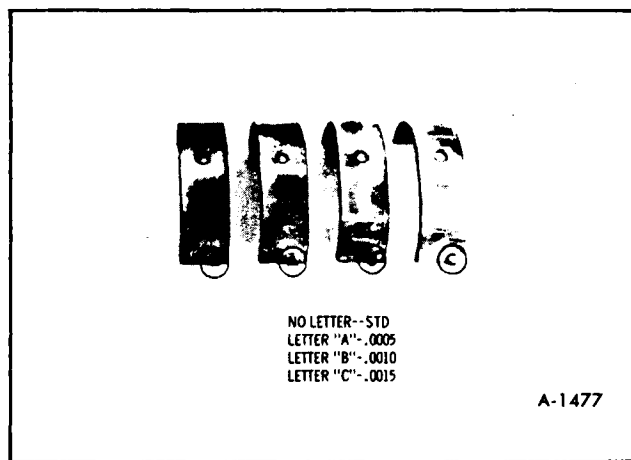

Figure 66—Main Bearing

To install main bearing shells, proceed as follows:

1. Remove bearing cap and remove lower shell.

2. Insert a flattened cotter pin, roll out pin or tool J-8080 (if available) in the oil passage hole in the crankshaft, then rotate the crankshaft in the direction opposite to cranking rotation. The pin will contact the upper shell and roll it out.

3. The main bearing journals should be checked for roughness and wear. Slight roughness may be removed with a fine grit polishing cloth saturated with engine oil. Burrs may be removed with a fine oil stone. If the journals are scored or ridged, the crankshaft must be replaced.

**NOTE:** The journals can be measured for out-of-round with the crankshaft installed by using a crankshaft caliper and inside micrometer or a main bearing micrometer. The upper bearing shell must be removed when measuring the crankshaft journals. Maximum out-of-round of the crankshaft journals must not exceed .0015".

4. Clean crankshaft journals and bearing caps thoroughly before installing new main bearings.

5. Apply Special Lubricant, No. 1050169 or equivalent to the thrust flanges of bearing shells on No. 3 bearing.

6. Place new upper shell on crankshaft journal with locating tang in correct position and rotate shaft to turn it into place using cotter pin or roll out pin as during removal.

7. Place new bearing shell in bearing cap.

8. No. 5 bearing - Install new asbestos oil seal in the rear main bearing cap as described later in this section. Install sealer on cap as shown.

9. Install bearing caps, lubricate bolt threads with No. 1050125 Lubricant or equivalent, and install.

Torque cap bolts to 120 ft. lbs.

10. Install oil pan. Refer to "Oil Pan" earlier in this section.

## REAR MAIN BEARING UPPER OIL SEAL

### REPAIR

Tool J-21526 is available to provide a means of correcting engine rear main bearing upper seal leaks with the necessity of removing the crankshaft. Replacement of the rear main bearing upper oil seal requires crankshaft removal. The procedure for seal leak correction is listed below.

1. Drain oil and remove oil pan and rear main bearing cap.

2. Insert Packing Tool J-21526-2 against one end of seal in cylinder block and drive the old seal gently into the groove until it is packed tight. This varies from 1/4" to 3/4" depending on the amount of pack required. See Figure 67.



Figure 67-Packing Seal Into Cylinder Block

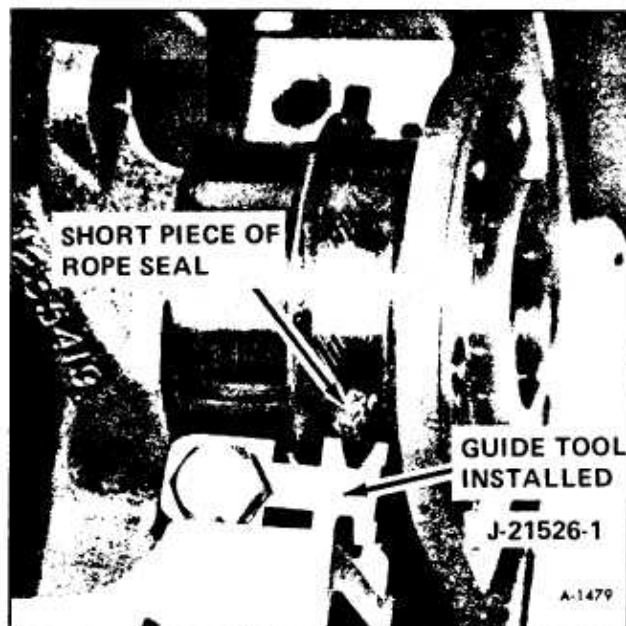

Figure 68-Guide Tool Installed

3. Repeat this on the other end of the seal in the cylinder block.

4. Measure the amount the seal was driven up on one side; add 1/16", then cut this length, from the old rear main lower oil seal removed from the cap, with a single edge razor blade. Measure the amount the seal was driven up on the other side. Add 1/16" and cut another length from old seal. Use main bearing cap as a holding fixture when cutting seal.

5. Place a drop of 1050026 Sealer or equivalent, on each end of seal and cap as indicated.

6. Work these two pieces of seal into the cylinder block (one piece on each side) with two small screwdrivers. Use guide tool J-21526-1 as shown in Figure 68. Using packing tool, pack these short pieces up into the block. See Figure 69.

**NOTE:** Place a piece of shim stock between seal and crankshaft to protect bearing surface before trimming.

7. Form a new rope seal in the rear main bearing cap. Refer to "Rear Main Lower Oil Seal" next in this section.

8. Assemble the cap to the block and torque to 120 ft. lbs.

### REPLACEMENT

1. Remove crankshaft. Refer to "Crankshaft" earlier in this section.

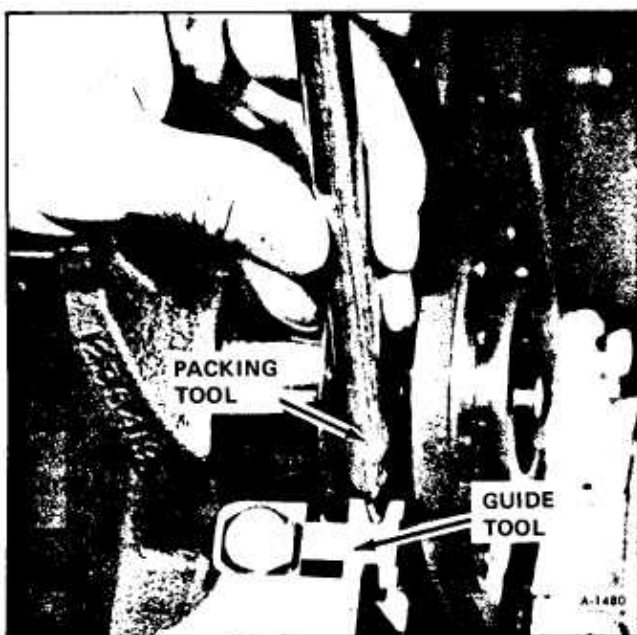

Figure 69—Packing Seal Into Guide and Cylinder Block

2. Remove upper oil seal.

3. Install a new rear main bearing upper seal. Use tool J-7588 as shown in Figure 70.

4. After correctly positioning seal, rotate tool slightly and cut off each end of seal flush with block.

5. Install crankshaft as described earlier in this section under "Crankshaft".

## REAR MAIN LOWER OIL SEAL

### REMOVAL

1. Remove oil pan. Refer to "Oil Pan" earlier in this section.

2. Remove the rear main bearing cap.

3. Remove rear main bearing insert and old seals.

4. Clean bearing cap and seal grooves and inspect for cracks.

### INSTALLATION

1. Install seal into bearing cap, packing by hand.

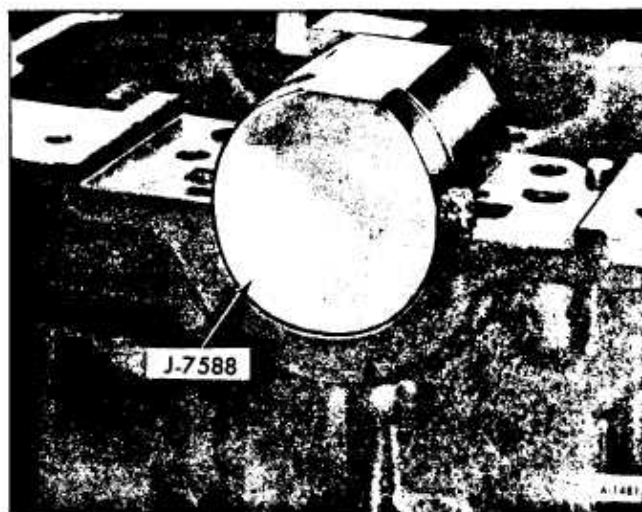

Figure 70—Installing Rear Main Seal—Upper Half

2. Using seal installer J-7588 hammer seal into groove. (See figure 71).

**NOTE:** To check if seal is fully seated in the bearing cap, slide the tool away from seal. With tool fully seated in the bearing cap, slide tool against the seal. If undercut area of tool slides over the seal, the seal is fully seated. If tool butts against the seal, the seal must be driven further into the seal groove. Rotate tool before cutting off excess seal packing.

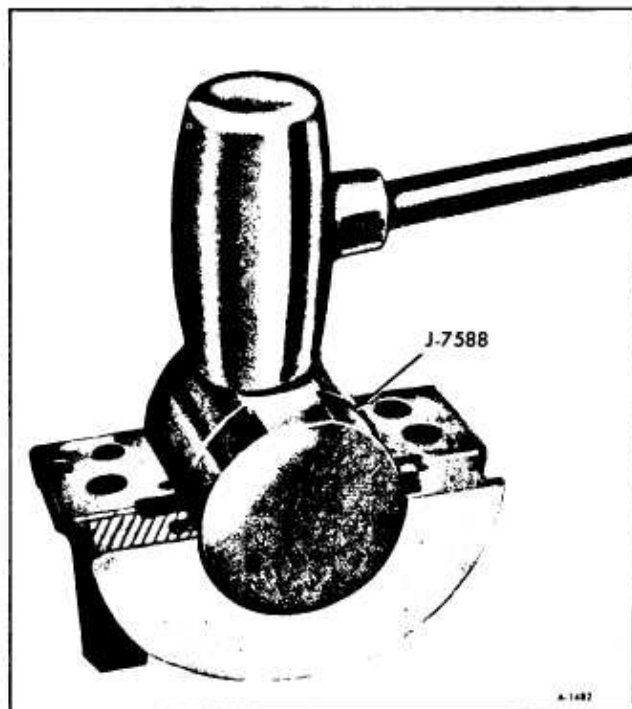

Figure 71—Installing Rear Main Seal—Lower Half



3. With tool slightly rotated, cut seal flush with mating surface. With screwdriver, pack seal end fibers towards center, away from edges. Rotate seal installer when cutting seal to avoid damage to tool.

4. Apply sealer on shaded areas of Figure 71.

5. Clean bearing insert and install in bearing cap.

6. Clean crankshaft bearing journal and seal contact. Install sealer on cap as shown.

7. Install bearing caps, lubricate bolt threads with No. 1050125 Lubricant or equivalent and install. Torque bearing cap bolts to 120 ft. lbs.

8. Install oil pan. Refer to "Oil Pan" earlier in this section.

## ENGINE SPECIFICATIONS

### CYLINDER BLOCK

Engine Type .....	90° V-Type
No. of Cylinders .....	8
Bore and Stroke .....	4.126" x 4.250"
Piston Displacement-455 cu. in.	
Compression .....	8.5:1
Firing Order .....	1-8-4-3-6-5-7-2
Main Bearing Bore (I.D.) .....	3.188" - 3.189"

### CRANKSHAFT

Diameter-Main Bearing Journal .....	3.0003" - 2.9993"
Width-Main Bearing Journal (with fillets)	
No. 1 .....	1.185"
No. 2 & 4 .....	1.156" - 1.166"
No. 3 .....	1.199" - 2.001"
No. 5 .....	1.882"
Diameter-Connecting Rod Bearing Journal .....	2.4998" - 2.4988"
Width-Connecting Rod Bearing (with fillets) .....	1.877" - 1.887"
Length-Overall Crankshaft .....	26.470"
Diameter - Oil Holes in Crankshaft .....	.201" - .223"
Clearance - Crankshaft End .....	.004" - .008"

### MAIN BEARINGS

Bearing Clearance - Crankshaft 1,2,3, & 4 .....	.0005" - .0021"
(Vertical) <sup>5</sup> .....	.0020" - .0034"
Width-Bearing Shell	
No. 1,2, and 4 .....	.970" - .980"
No. 3 .....	1.193" - 1.195"
No. 5 .....	1.624"

### CONNECTING RODS

Length-Center to Center .....	6.733" - 6.737"
Diameter-Connecting Rod Bore .....	2.6243" - 2.6250"
Diameter-Pin Bore .....	.9789" - .9795"
Bearing Clearance - (Vertical) .....	.0004" - .0033"
Side Clearance - Big End .....	.006" - .020"

### PISTON

Diameter Nominal Outside .....	4.1245"
Length Overall .....	3.490"
Top of Piston to Center of Pin .....	1.738" - 1.742"
Clearance at Thrust Surface (selective) .....	.001" - .002"
Weight Less Pin Rings .....	24.057 oz.
Skirt Taper .....	.0005" - .0015" Larger at Bottom
Ring Width (2 compression) .....	.0798" - .0808"
Ring Width (1 oil) .....	.1881" - .1891"

### PISTON PINS

Diameter .....	.9803" - .9807"
Length Overall .....	2.980"
Pin to Piston Clearance .....	.0003" - .0005"
Pin to Rod Fit .....	.0008" - .0018" Press



**PISTON RINGS**

No. of Compression Rings (per piston) .....	2
Width of Compression Rings (top bottom) .....	.0770" - .0780"
Gap Clearance Compression Rings.....	.010" - .023"
Clearance in Groove Compression Rings-Upper .....	.0020" - .0040"
Lower .....	.0020" - .0040"
No. of Oil Rings (per piston) .....	1
Gap Clearance, Oil Ring.....	.015" - .055"

**CAMSHAFT****Bearing Journal Diameters**

No. 1.....	2.0365" - 2.0357"
No. 2.....	2.0165" - 2.0157"
No. 3.....	1.9965" - 1.9957"
No. 4.....	1.9765" - 1.9757"
No. 5.....	1.9565" - 1.9557"

**Width (including chamfers)**

No. 1.....	.810"
No. 2, 3 and 4 .....	.741"
No. 5.....	.788"

Journal Clearance in Bearing (all) ..... .0020" - .0058"

End Clearance ..... .011" - .077"

Push Rod - Length ..... 9.570"

**VALVE - INTAKE**

Diameter Head..... 2.000" - 1.990"

Diameter - Stem..... .3425" - .3432"

Angle - Valve (A°) See Fig. 26 ..... 44°

Angle - Valve Seat (B°) See Fig. 26 ..... 45°

Width - Valve Seat (Cylinder Head) ..... .037" - .075"

Overall Length..... 4.667"

Clearance in Guide ..... .0010" - .0027"

Lash ..... Hydraulic

**VALVE EXHAUST**

Diameter - Head ..... 1.627" - 1.617"

Diameter - Stem..... .3420" - .3427"

Angle - Valve (A°) See Fig. 26 ..... 30°

Angle - Valve Seat (B°) See Fig. 26 ..... 31°

Width - Valve Seat (Cylinder Head) ..... .050" - .090"

Overall Length..... 4.675"

Clearance In Guide ..... .0015" - .0032"

Lash ..... Hydraulic

**VALVE SPRINGS**

Length ..... 1.96"

Diameter - Wire..... .192"

Inside Diameter ..... 1.065" - 1.041"

Load ..... 76 - 84 Lbs. @ 1.620"

Load @ 1.270" ..... 180 - 194 Lbs.

**VALVE LIFTERS**

\*Diameter - Body ..... .8422" - .8427"

Length - Overall..... 2.000"

Clearance in Boss..... .0005" - .0020"

\*Also available in .010" Over Size

**CAMSHAFT SPROCKET**

Width of Sprocket ..... .529" - .521"

Pitch ..... .500"

No. of Teeth..... 471" - 461"

**CRANKSHAFT SPROCKET**

Width of Sprocket ..... .529" - .521"

Overall Width of Gear ..... 1.001" - .991"

Pitch ..... .500"

No. of Teeth..... 18

## TIMING CHAIN

Width .....	Morse-.762, Linkbelt-.844"
No. of Links.....	48
Pitch .....	.500"

## FLYWHEEL

No. of Teeth on Starter Gear .....	166
No. of Teeth on Starter Pinion.....	9

## LUBRICATION SYSTEM

Crankcase Capacity Drain and Refill.....	5 Qts.
Drain Refill with Filter Change .....	6 Qts.
Oil Pump	
Clearance Pressure Relief Valve in Bore .....	.0025" - .0050"
End Clearance-Gear.....	.0025" - .0065"

## TORQUE SPECIFICATIONS

Specified torque is for installation of parts only. Checking of torque during inspection may be 10% below specification.

APPLICATION	FT. LBS.
<b>FUEL PUMP</b>	
Fuel Pump to Block Bolt and Nut.....	25
Fuel Pump to Eccentric to Camshaft.....	65
<b>EXHAUST SYSTEM</b> .....	15-20
<b>ENGINE</b>	
Crankshaft Bearing Cap Bolts.....	120
Flywheel to Crankshaft .....	60
Oil Pump to Bearing Cap Bolts .....	35
Oil Deflector to Bearing Cap .....	35
Oil Pump Cover to Pump Bolts .....	8
Rocker Arm Pivot Bolt to Head .....	25
Valve Cover Bolts .....	7
Oil Pan Bolts .....	10
Oil Pan Drain Plug .....	30
Crankshaft Balancer or Hub to Crankshaft Bolt.....	160 Min.
Oil Filter Element to Base .....	20
Oil Filter Assembly to Cylinder Block Bolts.....	35
Oil Filter Extension Fitting.....	55
Support/Front Cover Block .....	50
Fan Driving Pulley to Balancer Bolts .....	10
Fan Clutch Assembly to Pulley Nuts.....	15
Water Pump to Front Cover Bolts.....	13
Water Outlet to Manifold Bolts .....	20
*Intake Manifold to Cylinder Head Bolts .....	40
Exhaust Manifold to Cylinder Head Bolts.....	25
Carburetor to Intake Manifold Bolts .....	15
Choke Tube and Plate to Intake Manifold Bolts.....	15
Air Cleaner to Carburetor Stud .....	5
Engine Front Support Cushion Studs.....	30
Engine Support to Mount .....	45
Engine Mount to Crossmember Mount .....	30
Transmission Rear Mount to Crossmember.....	55
Transmission Rear Mount to Support .....	50
Starter to Cylinder Block Bolts.....	35
Distributor Clamp to Cylinder Block Bolt.....	17
Spark Plugs .....	35
Coil to Intake Manifold Bolt .....	15
*Cylinder Head Bolts .....	85
Connecting Rod Nuts .....	42

\*Clean and dip entire bolt in engine oil before tightening to obtain a correct torque reading.

## **SPECIAL TOOLS**

J-5194	Timing Cover Oil Seal Installer
J-5892-1	Valve Spring Compressor
J-6647	Piston Ring Compressor (3-7/8")
J-7583-3	Pilot (used with J-8614-01 Harmonic Balancer Remover)
J-7588	Rear Main Bearing Oil Seal Installer
J-8080	Main Bearing Shell Remover
J-21526-1	Rope Seal Repair Guide Tool
J-21526-2	Rope Seal Repair Packing Tool
J-22794	Valve Holder
J-24603	Engine Removal Fixture
J-24724	Crankshaft Harmonic Balancer Installer
J-24725	Valve Stem Seal Installer
J-23600	Belt Tension Gauge

# SECTION 6K

## ENGINE COOLING

Contents of this section are listed below:

SUBJECT	PAGE NO.
General Description.....	6K-1
Cooling System Trouble Diagnosis.....	6K-3
Draining, Flushing and Refilling Cooling System.....	6K-4
Water Pump.....	6K-5
Thermostat.....	6K-6
Fan/Fan Clutch.....	6K-7

**IMPORTANT:** For maintenance recommendations and cooling system capacities, refer to section 0 of this manual.

### GENERAL DESCRIPTION

The engine cooling system is the closed-pressure type with thermostatic control of coolant circulation. The radiator is equipped with separate coolers in the right tank which aid in cooling engine oil and automatic transmission fluid (See figure 1).

The cooling system is sealed by a pressure type radiator filler cap which causes the system to operate at higher than atmospheric pressure. The higher pressure raises the boiling point of the coolant and increases the cooling efficiency of the radiator. The 9 pound pressure cap used raises the coolant boiling point approximately 22 degrees F.

The pressure type radiator filler cap contains a blow off or pressure valve and a vacuum or atmospheric valve. The pressure valve is held against its seat by a spring of predetermined strength which protects the radiator by relieving the pressure if the pressure should exceed that for which the radiator is designed.

The vacuum valve is held against its seat by a light spring which permits opening of the valve to relieve vacuum created when the system cools off.

A pressure-vacuum valve radiator cap is used which allows the coolant to expand through the pressure valve in the center of the cap without building unnecessary pressure. The expanding coolant flows into the coolant reservoir (See figure 2). The vent valve closes due to expansion and coolant flow. The nominal 9 pound pressure will not be reached until the system is working at maximum capacity.

Any air or vapor in the cooling system will be forced to the coolant reservoir under the liquid level and leave through the vent tube at the top of the reservoir. As the system cools, the extra coolant in the reservoir will be drawn back to the radiator through the vent valve. In this manner, the radiator will keep itself full at all times. The need for additional coolant can be detected by observing the level of coolant in the reservoir at the "COLD" level line when the engine is cold.

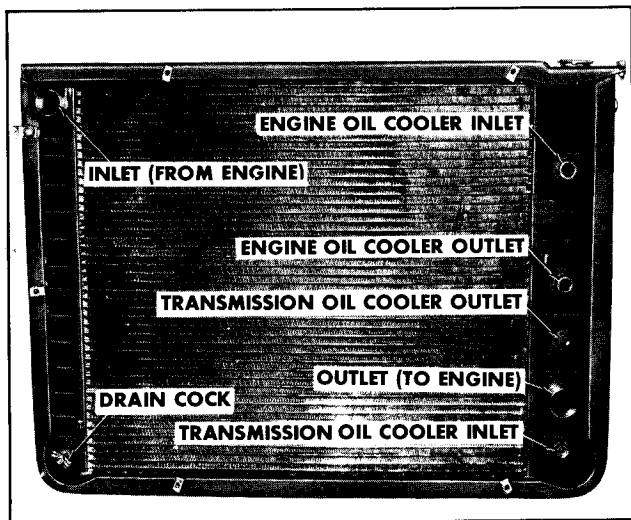

Figure 1-Radiator Core

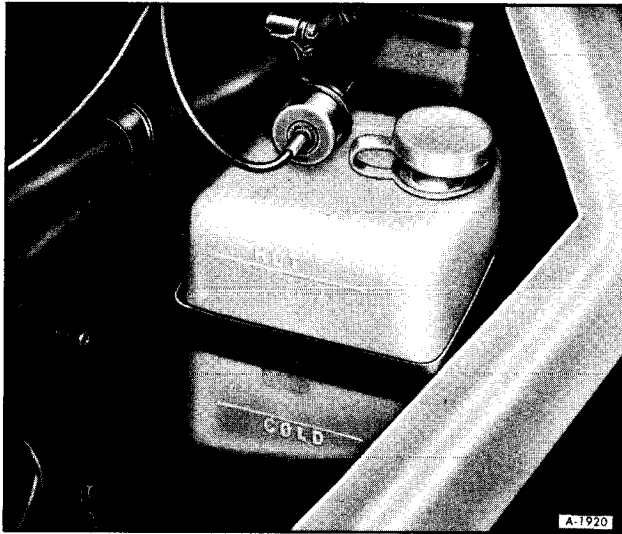

Figure 2—Coolant Recovery Reservoir

## COOLING SYSTEM CIRCULATION (FIGURE 3)

The coolant is circulated by a centrifugal pump mounted on the front engine cover which forms the outlet side of the pump. The engine fan and pulley(s) are bolted to the pump shaft hub at its forward end. Thus both the fan and pump are belt driven by a crankshaft pulley bolted to the harmonic balancer. The pump shaft and bearing assembly is pressed in the water pump cover. The bearings are permanently lubricated during manufacture and sealed to prevent loss of lubricant and entry of dirt. The pump is sealed against coolant leakage by a packless non-adjustable seal assembly mounted in the pump in position to bear against the impeller hub. The inlet pipe cast in the pump body feeds into the passage formed by the cover and the front face of the impeller, which is mounted on the bearing shaft with the vanes facing forward. Coolant flows through the inlet passage to the low pressure area at the center where it then flows radially through six openings in the impeller. Vanes on the rotating impeller cause the coolant to flow rearward through two discharge passages cast in the engine block. These passages deliver an equal

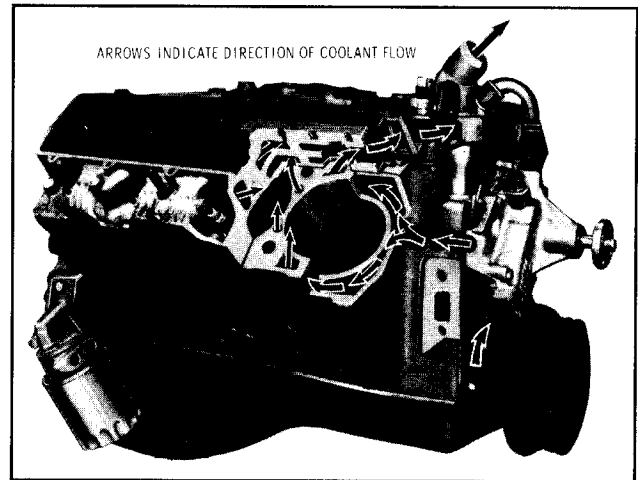

Figure 3—Cooling System Circulation

quantity of coolant to each cylinder bank water jacket.

The coolant then flows rearward through the water jacket which surrounds each cylinder barrel and extends below the lower limit of piston ring travel. After flowing the full length of the cylinder banks, the coolant flows up through openings to the rear of the cylinder bank into the cylinder heads. The coolant flows forward in the cylinder heads to cool the combustion chamber areas.

Next, the coolant flows into the intake manifold water passage from the forward port of the cylinder heads to the thermostat housing and thermostat by-pass. A nipple in the pump body allows connection of the heater hose.

A pellet type thermostat housed in the forward (outlet) end of the intake manifold controls the circulation of water through the engine radiator. During cold engine operation when the thermostat is closed, a thermostat by-pass, open at all times, allows recirculation of coolant through the engine to provide rapid warm-up. When the thermostat opens, (195 degrees F.) coolant is directed to the left tank of the radiator, through the radiator core and right tank to the water pump inlet where the cycle is repeated.

## COOLING SYSTEM TROUBLE DIAGNOSIS

Problem	Possible Cause	Correction
<p>Engine overheats (Engine temperature gauge indicates coolant temperature is HOT or coolant overflows from reservoir onto ground while engine is running).</p>	<p>Loss of coolant.</p> <p>Low coolant protection (should be -20°). Belt tension too low.</p> <p>Ignition timing retarded.</p> <p>Timing retarded by sticking or inoperative vacuum or mechanical advance. Thermal Vacuum Switch (T.V.S.) not switching.</p> <p>Radiator fins obstructed.</p> <p>Cooling system passages blocked by rust or scale. Reservoir hose pinched or kinked (especially at radiator filler neck). Lower radiator hose collapses.</p> <p>Defective fan clutch.</p>	<p>See "Loss of Coolant" condition below pressure check system with suitable checking equipment. Correct as necessary.</p> <p>Test solution. Add 50/50 coolant/water solution as required. Check with J-23600. Adjust if loose.</p> <p>Set timing to specifications. See "Engine Electrical" later in this manual. Check and correct. See "Engine Electrical" later in this section.</p> <p>Test and replace if necessary. See "Thermal Vacuum Switch" later in this section.</p> <p>Clean away bugs, leaves, etc.</p> <p>Flush system—add fresh coolant.</p> <p>Relieve kinks by re-routing. Replace if permanently kinked.</p> <p>Check for hose spring position by squeezing lower end of hose. Replace if necessary. Replace fan clutch.</p>
<p>Loss of coolant.</p>	<p>Leaking radiator.</p> <p>Radiator cap defective, or filler neck distorted.</p> <p>Leaking coolant reservoir or hose. Loose or damaged hoses or connections.</p> <p>Water pump seal leaking. Water pump gasket leaking. Improper cylinder head bolt torque. Cylinder head or gaskets, cylinder block or core plug, heater core or heater water valve leaking.</p>	<p>Inspect cooling system. Repair or replace as required. Pressure check radiator and cap with suitable testing equipment. If neck upper sealing area is distorted, use wood block and mallet to reform evenly so cap will fit. Replace reservoir or hose.</p> <p>Reseat or replace hoses or clamps. Include hoses to pre-heater if equipped. Replace water pump. Replace gasket. Torque bolts to 85 ft. lbs.</p> <p>Repair or replace as necessary to correct.</p>

## COOLING SYSTEM TROUBLE DIAGNOSIS (Cont'd.)

Problem	Possible Cause	Correction
Loss of coolant.	Thermostat stuck in closed position.	Replace thermostat.
Engine fails to reach normal operating temperature. Indicated by cool air blown from heater.	Thermostat stuck open or wrong type thermostat.  Coolant below add mark.	Install new thermostat of correct type and heat range.  Add coolant (50/50-coolant/water solution).
HOT reading indicated on temperature gauge with no loss of coolant.	Defective engine temperature switch.	Replace switch.

## DRAINING, FLUSHING AND REFILLING COOLING SYSTEM

Before draining the cooling system, inspect the system and perform any necessary service to insure that it is clean, does not leak and is in proper working order.

**CAUTION:** *To avoid the danger of being burned, and prevent loss of coolant, do not remove the radiator cap while the engine and radiator are still hot, because the cooling system will blow out scalding fluid and steam under pressure.*

1. Run engine, with radiator cap removed, until normal operating temperature is reached. On air conditioned models (automotive type), open water temperature control valve by moving the heater temperature control to maximum temperature position.

2. With engine stopped, drain radiator coolant by opening radiator drain valve located at the lower left corner of the radiator as shown in Figure 4. Remove engine block drain plug on right lower side of block if desired.

3. Close radiator drain valve, install block drain plug, if removed, add sufficient water to fill system.

4. Run engine, drain and refill the system, as described in Steps 1, 2 and 3, a sufficient number of times until the drained liquid is nearly colorless.

5. Allow system to drain completely and install block drain plugs, if removed.

6. Fill radiator to filler neck with coolant meeting GM Specification 1899-M (for ease and speed of filling use a 20-inch length of rubber hose and funnel to add coolant at radiator cap), to provide the required freezing and corrosion protection (at least a 44 percent solution for -20°F.) Install radiator cap.

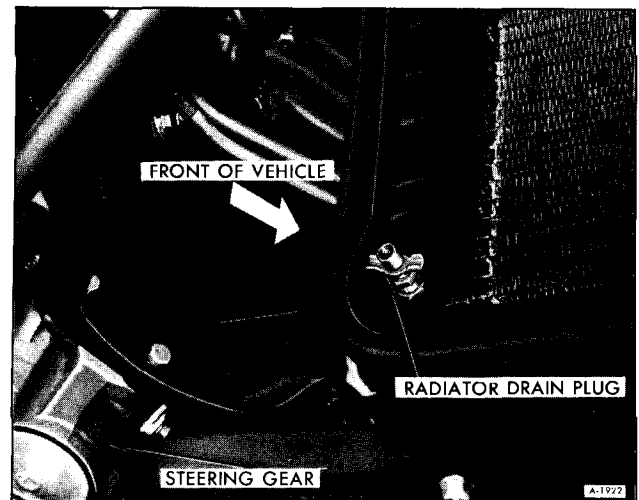

Figure 4-Radiator Drain Plug

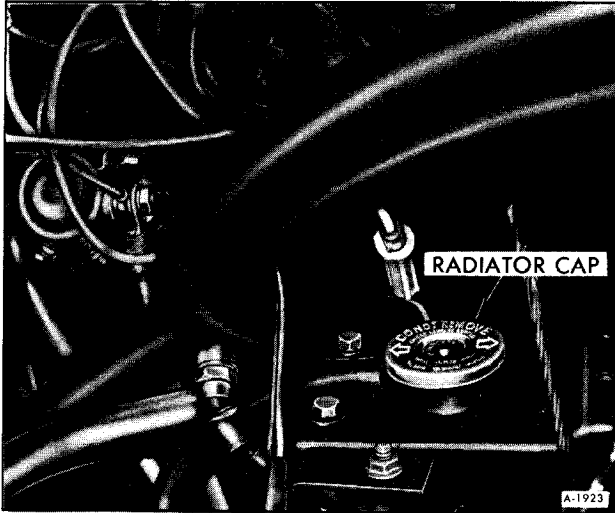

Figure 5-Radiator Cap

Make certain arrow on cap lines up with overflow tube. See Figure 5.

7. Fill reservoir to "COLD" level mark. See Figure 2.

8. Add anti-foam GM-1050531 to vehicles equipped with automotive air conditioning. Run engine with heater controls in "HEATER" and "HOT" position until normal operating temperature is reached.

9. Check and adjust coolant to proper level. Install coolant reservoir cap.

**CAUTION:** *Vehicles equipped with water heater pre-heat must have coolant checked at reservoir and coolant added as necessary after checking several times. The additional heater hose used for the pre-heat requires a longer period to normalize the cooling system.*

## WATER PUMP

### REMOVAL

1. Drain radiator. Disconnect bypass and remove heater hose from water pump. Loosen all belts.

2. Raise Motor Home. Disconnect lower radiator hose from water pump.

3. Remove venturi ring seal strap.

4. Fold venturi ring to shroud seal forward and over shroud.

5. Remove four (4) nuts attaching fan clutch to water pump hub. See Figure 6. Position fan and fan clutch assembly forward in the shroud. Be careful not to allow the assembly to damage the radiator core.

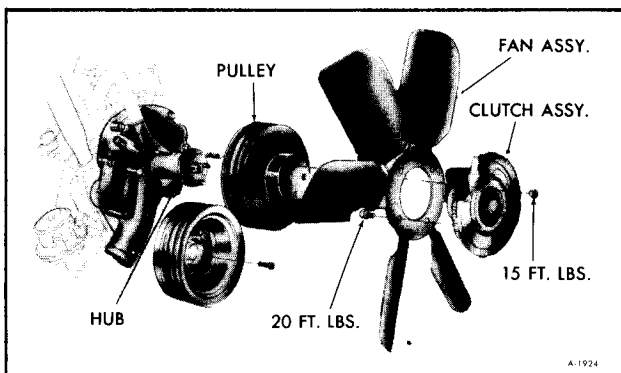

Figure 6-Fan Installation

6. Remove the venturi ring.

7. Remove water pump pulley.

8. Disconnect the power steering pump and L.H. upper venturi ring bracket.

9. Remove water pump attaching bolts. Remove water pump.

10. Clean engine block of old gasket at sealing surfaces.

### INSTALLATION

1. Apply a thin coat of 1050026 Sealer or equivalent to the pump housing to retain the new gasket, then position on the housing.

2. Install the pump assembly. Coat all bolts with engine oil and torque the self-tapping bolts to 13 ft. lbs. and torque the others to 25 ft. lbs.

3. Connect the power steering pump bracket and the L.H. upper venturi ring bracket. Torque nut to 22 ft. lbs.

4. Install venturi ring and torque nuts to 25 ft. lbs.

5. Install water pump pulley. Reposition all belts.



6. Install fan and fan clutch assembly. Torque four (4) nuts to 15 ft. lbs. (See figure 6).
7. Reposition shroud to venturi ring seal over venturi ring.
8. Install venturi ring seal strap.
9. Connect lower radiator hose to water pump.

10. Lower motor home.
11. Secure clamp on bypass hose and install heater hose to water pump.
12. Tension belts. Refer to "Belt Tension" in Section 6A in this manual.
13. Refill radiator. If new coolant is used refer to Section 0.

## THERMOSTAT

The thermostat consists of a restriction valve actuated by a thermostatic element. A 195° thermostat is used and the use of thermostats rated above 195 degrees F. control temperatures are not recommended. This is mounted in the housing at the cylinder head water outlet above the water pump. The thermostat should be installed with the word **FRONT** up and toward the radiator. This way the coolant has a smooth unobstructed flow through the thermostat and water outlet. See Figure 7.

When the thermostat is incorrectly installed, as in "B" shown in Figure 7, the thermostat valve acts as a baffle, forcing the coolant to change direction to pass around the valve. This change in direction interrupts the smooth unobstructed flow of coolant to the

radiator and can possibly result in overheating conditions.

Thermostats are designed to open and close at predetermined temperatures and if not operating properly should be removed and tested.

An operational check of the thermostat can be made by hanging thermostat on a hook in a 33% glycol solution at 220°F. Submerge the valve completely and agitate the solution thoroughly. Under this condition the valve should open. Remove the thermostat and place in a solution of 33% glycol solution at 185°F. With the valve completely submerged and the solution agitated thoroughly, the valve should close completely.

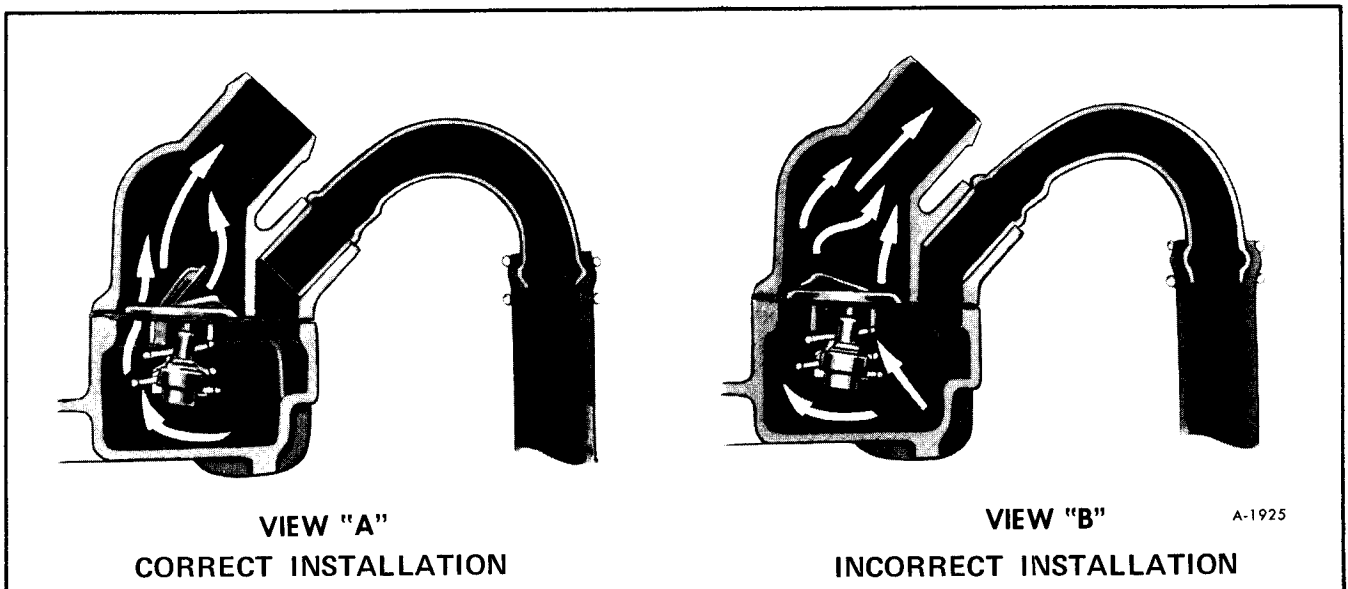

Figure 7—Thermostat Installation

# FAN AND FAN CLUTCH

## REMOVAL

1. Raise motor home.
2. Remove shroud to venturi ring seal retainer strap.
3. Fold venturi ring to shroud seal forward and over shroud.
4. Remove the four (4) nuts attaching fan clutch to water pump hub (See figure 6).
5. With assembly in the shroud area and removed from the hub, remove the four (4) attaching bolts that secures fan clutch.
6. Remove fan and fan clutch after they are separated.

**WARNING: IF A FAN BLADE IS BENT OR DAMAGED IN ANYWAY, NO ATTEMPT SHOULD BE MADE TO REPAIR AND REUSE THE DAMAGED PART. A BENT OR DAMAGED FAN ASSEMBLY SHOULD ALWAYS BE REPLACED WITH A NEW FAN ASSEMBLY. IT IS ESSENTIAL THAT FAN ASSEMBLIES REMAIN IN PROPER BALANCE AND PROPER BALANCE CANNOT BE ASSURED ONCE A FAN ASSEMBLY HAS BEEN BENT OR DAMAGED. A FAN ASSEMBLY THAT IS NOT IN PROPER BALANCE COULD FAIL AND FLY APART DURING SUBSEQUENT USE CREATING AN EXTREMELY DANGEROUS CONDITION.**

## INSTALLATION

1. Install fan and fan clutch separately into the area in the shroud between the water pump and the radiator. Be careful not to damage the radiator core.
2. Install four (4) attaching bolts that secure the fan to the fan clutch and torque to 20 ft. lbs. (See figure 6).
3. Position the assembly over the water pump hub studs and torque the attaching nuts to 15 ft. lbs.
4. Fold venturi ring to shroud seal back over the venturi ring.
5. Install seal retainer strap.
6. Lower Motor Home.

## FAN CLUTCH

Automatic fan clutches, Figure 8, are hydraulic devices used to vary the fan speed in relation to the engine temperature. Automatic fan clutches permit the use of a high delivery fan to insure adequate cooling at reduced engine speeds while eliminating overcooling, excessive noise, and power loss at high speeds.

The automatic fan clutch has two modes of operation, the engaged mode and the disengaged mode. The disengaged mode (engine cold or high speed driving) occurs when the silicone fluid is contained in the reservoir area of the fan clutch. As the temperature of the engine rises so does the temperature of the bimetallic coil. This bimetallic coil is connected to the arm shaft in such a way that as the temperature rises the shaft moves the arm exposing and opening the pump plate. This opening allows the silicone fluid to flow from the reservoir into the working chamber of the automatic fan clutch. The silicone fluid is kept circulating through the fan clutch by wipers located on the pump plate. A hole is located in front of each wiper.

The speed differential between the clutch plate and the pump plate develops high pressure areas in front of the wipers, thus the fluid is forced back into the reservoir. But as the temperature rises the arm uncovers more of the large opening and allows more of the silicone fluid to re-enter the working chamber. The automatic fan clutch becomes fully engaged when the silicone fluid, circulating between the working chamber and the reservoir, reaches a sufficient level in the working chamber to completely fill the grooves in the clutch body and clutch plate. The resistance of the silicone fluid to the shearing action caused by the speed differential between the grooves

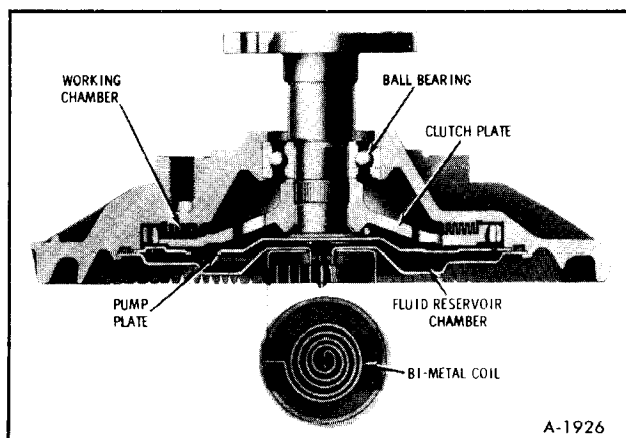

Figure 8—Fan Clutch Assembly

transmits torque to the clutch body. The reverse situation occurs when the temperature drops. The arm slowly closes off the return hole thus blocking the fluid flow from the reservoir into the working chamber. The continuous action of the wipers removes the silicone fluid from the grooves in the working chamber and reduces the shearing action. Thus, less torque is transmitted to the clutch body and the speed of the fan decreases.

The temperature at which the automatic fan clutch engages and disengages is controlled by the setting of the bimetallic coil. This setting is tailored to satisfy the cooling requirement of the Motor Home.

## FAN CLUTCH TROUBLE DIAGNOSIS

### 1. NOISE

Fan noise is sometimes evident under the following normal conditions:

a. When clutch is engaged for maximum cooling.

b. During first few minutes after start-up until the clutch can re-distribute the silicone fluid back to its normal disengaged operating condition after overnight setting.

However, fan noise or an excessive roar will generally occur continuously under all high engine speed conditions (2500 rpm and up) if the clutch assembly is locked up due to an internal failure. If the fan cannot be rotated by hand or there is a rough grating feel as the fan is turned, the clutch should be replaced.

### 2. LOOSENESS

Under various temperature conditions, there is a visible lateral movement that can be observed at the tip of the fan blade. This is normal condition due to the type of bearing used. Approximately 1/4" maximum lateral movement measured at the fan tip is allowable. This is not cause for replacement.

### 3. SILICONE FLUID LEAK

The operation of the unit is generally not affected by small fluid leaks which may occur in the area around the bearing assembly. However, if the degree of leakage appears excessive, proceed to item 4.

### 4. ENGINE OVERHEATING

a. Start with a cool engine to insure complete fan clutch disengagement.

b. If the fan and clutch assembly free-wheels with no drag (revolves over 5 times when spun by hand), the clutch should be replaced. If clutch performs properly with a slight drag go to Step C.

**NOTE:** Testing a fan clutch by holding the small hub with one hand and rotating the aluminum housing in a clockwise/counterclockwise motion will cause the clutch to free-wheel, which is normal condition when operated in this manner. This should not be considered a test by which replacement is determined.

c. Position thermometer so that it is located between the fan blades and radiator. This can be achieved by inserting the sensor through one of the existing holes in the fan shroud or fan guard, or by placing between the radiator and the shroud. On some models, it may be necessary to drill a 3/16" hole in the fan shroud to insert thermometer.

**CAUTION:** *Check for adequate clearance between fan blades and thermometer sensor before starting engine.*

d. With thermometer in position, cover radiator grille sufficiently to induce a high engine temperature. Start engine and turn on A/C if equipped, operated at 2,000 rpm.

e. Observe thermometer reading when clutch engages. It will take approximately 5 to 10 minutes for the temperature to become high enough to allow engagement of the fan clutch. This will be indicated by an increase or roar in fan air noise and by a drop in the thermometer reading of approximately 5-15 degrees F. If the clutch did not engage between 150-190 degrees F. the unit should be replaced.

**NOTE:** Be sure fan clutch was disengaged at beginning of test.

If no sharp increase in fan noise or temperature drop was observed and the fan noise level was constantly high from start of test to 190 degrees F, the unit should be replaced. Do not continue test past a thermometer reading of 190 degrees F. to prevent engine overheating.

f. As soon as the clutch engages, remove the radiator grille cover and turn off the A/C to assist in engine cooling. The engine should be run at approximately 1500 rpm.

g. After several minutes the fan clutch should disengage, as indicated by a reduction in fan speed and roar.

If the fan clutch fails to function as described, it should be replaced.



# SECTION 6M ENGINE FUEL SYSTEM

Contents of this section are listed below:

SUBJECT	PAGE NO.
Carburetor .....	6M-1
General Description.....	6M-1
Theory of Operation .....	6M-2
Carburetor Diagnosis.....	6M-6
Carburetor Replacement .....	6M-14
Carburetor Adjustments .....	6M-21
Accelerator Linkage .....	6M-26
Fuel Pump .....	6M-26
Air Cleaner .....	6M-27

## CARBURETOR

### GENERAL DESCRIPTION

The Model 4MC (Quadrajets) is a 4 barrel carburetor having two stages of operation.

The primary (fuel inlet) side has two small bores each with a triple venturi which are equipped with a discharge nozzle. Fuel is metered to the primary bores by two tapered metering rods connected to a power piston which is actuated by manifold vacuum.

The secondary side has two very large bores which have greatly increased air capacity to meet engine demands. The air valve opens as air velocity increases and thereby controls the air/fuel mixture in the secondary bores. This mixture combines with the fuel mixture in the primary side. Using the air valve principle, fuel is metered in direct proportion to the air passing through the secondary bores.

The fuel reservoir is centrally located and uses a single float pontoon.

A pleated paper fuel filter is mounted in the fuel inlet casting of the float bowl and is easily removed for replacement.

Carburetor identification information is located as shown on Figure 1. If replacing a float bowl assembly, follow the directions received in the service package to transfer the information.

The primary side of the carburetor has six systems of operation. They are float, idle, main metering, power, pump, and choke. The secondary side has one metering system for controlling the air/fuel mixture which combines with the primary side. The primary and secondary side receive fuel from a common float bowl.

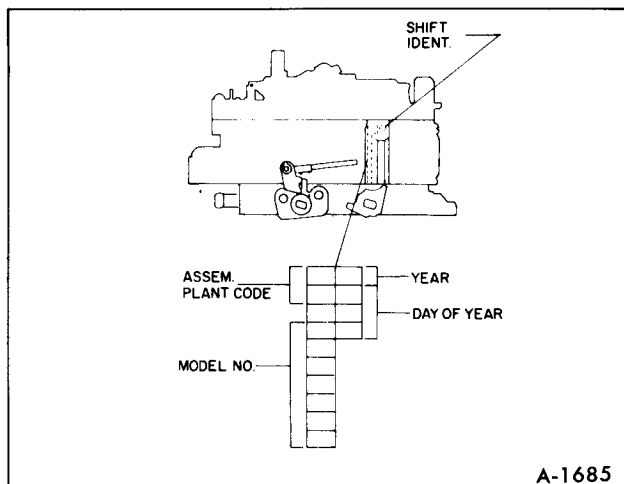

A-1685

Figure 1—Carburetor Identification

## THEORY OF OPERATION

### FLOAT SYSTEM (FIGURE 2)

The float system consists of a float chamber, plastic float pontoon assembly, float hinge pin and retainer combination, a float valve and needle assembly and a needle valve pull clip. The float system operates as follows:

Fuel from the engine fuel pump enters the carburetor fuel inlet passage. It passes through the filter element and on into the float inlet valve chamber. The open needle valve allows fuel to enter the float bowl.

As incoming fuel fills the float bowl to the prescribed fuel level, the float pontoon rises and forces the fuel inlet valve closed, shutting off all fuel flow. As fuel is used from the float bowl, the float drops and allows more incoming fuel to enter the float bowl until the correct fuel level is reached. This cycle continues constantly maintaining a positive fuel level in the float bowl.

A needle valve pull clip is used to assist in lifting the needle valve off its seat whenever fuel pump pressure or the fuel level in the float bowl is low.

A plastic filler block is located in the top of the float chamber in the area just above the float valve. This block prevents fuel slosh on severe brake applications maintaining a more constant fuel level to prevent stalling.

The carburetor float bowl is internally vented. Internal vent tubes are located in the primary side of the carburetor air horn just above the float bowl. The purpose of the internal vents is to equalize the air

pressure on the fuel in the float bowl with the air pressure within the air cleaner. Therefore, a balanced air/fuel mixture ratio can be maintained during part throttle and power operation because the same pressure acting upon the fuel in the float bowl will be balanced with the air flow through the carburetor bores. The internal vent tubes allow the escape of fuel vapors in the float bowl during hot engine operation. This prevents fuel vaporization from causing rich mixtures due to excessive pressure in the float bowl.

### IDLE SYSTEM (FIGURE 3)

The idle system is only used in the two primary bores of the carburetor. Each bore has a separate idle system. They consist of: Idle tubes, idle passages, idle air bleeds, idle channel restrictions, idle mixture needles, and idle discharge holes. Idle mixture screw limiter caps are installed on all carburetors. The screws are preset at the factory and **SHOULD NOT BE REMOVED**.

During curb idle, the primary throttle valves are held slightly open by the throttle stop screw to give the engine the desired idle speed. Since the engine requires very little air for idle and low speeds, the idle discharge holes below the throttle valves are exposed directly to engine manifold vacuum. With the idle discharge holes in a very low pressure area and the fuel in the float bowl vented to atmosphere (high pressure), the idle system operates as follows:

Engine manifold vacuum at the idle discharge ports causes fuel to flow from the float bowl through the primary metering jets into the main fuel wells. The fuel is picked up and metered at the lower tip of the idle tubes. It passes up through the idle tubes, then through a cross channel in the air horn casting to the idle down channels where it is mixed with air at a side idle bead located just above the idle channel restriction. The mixture continues downward

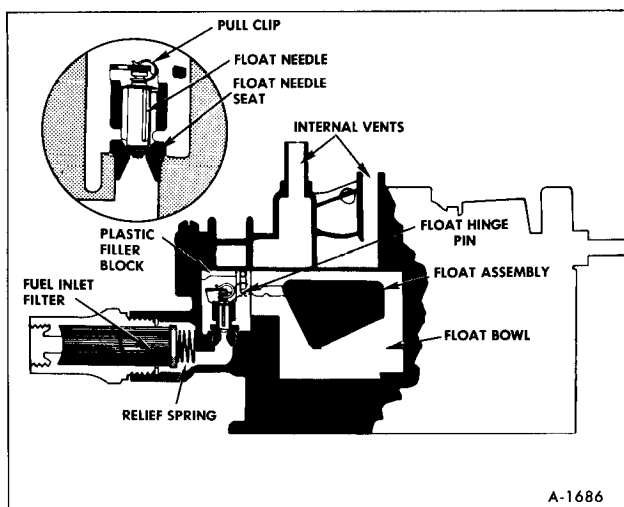

Figure 2—Float System

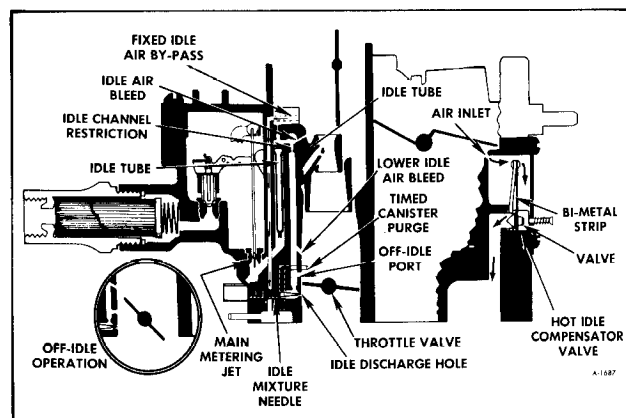

Figure 3—Idle System

through the calibrated idle channel restrictions, past the lower idle air bleeds and off-idle discharge ports, where it is further mixed with air. The air fuel mixture moves down to the idle mixture needle discharge holes where it enters the carburetor bores and blends with air passing the slightly open throttle valves. The combustible mixture then passes through the intake manifold to the engine cylinders.

A fixed idle air by-pass system is used to supplement the idle air passing by the slightly open throttle valves. The purpose of the idle air by-pass is to reduce the amount of air going through the carburetor bores and still maintain sufficient air for the correct idle speed. This reduces the amount of air passing through the venturi system to prevent the main fuel nozzles from feeding at idle. The venturi system is very sensitive to air flow and where large amounts of air is needed to maintain idle speeds, the fixed idle air by-pass system is used.

In that the fuel tank will not be vented to atmosphere, all fuel vapors are collected in a vapor collection canister. A timed purge port is provided in the carburetor throttle body above the throttle valves adjacent to the off-idle discharge ports. The timed bleed purge holes provide adequate purge to remove all vapors that will be collected in the vapor canister. They will bleed constantly during off-idle and part throttle operation of the engine.

## OFF-IDLE OPERATION

As the primary throttle valves are opened from curb idle, additional fuel is needed to combine with the extra air entering the engine. This is accomplished by the slotted, off-idle discharge ports. The primary throttle valves open gradually exposing the off-idle ports to high engine vacuum below the throttle valves. The additional fuel added from the off-idle ports mixes with the increasing air flow past the opening throttle valves to meet increased engine air and fuel demands.

Further opening of the throttle valves causes low pressure at the lower idle air bleeds. As a result, fuel begins to discharge from the lower idle air bleed hole and continues to do so from part throttle to wide open throttle.

## MAIN METERING SYSTEM (FIGURE 4)

The main metering system consists of main metering jets, vacuum operated metering rods, main fuel well, main well air bleeds, fuel discharge nozzles, and triple venturi. The system operates as follows:

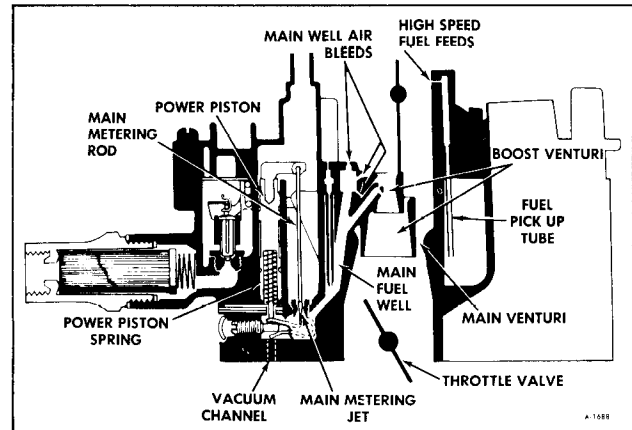

Figure 4—Main Metering System

During cruising speeds and light engine loads, engine manifold vacuum is high. Manifold vacuum holds the main metering rods down in the main metering jets against spring tension. Manifold vacuum is supplied through a channel to the vacuum operated power piston connected to the primary main metering rods. Fuel flow from the float bowl is metered between the metering rods and main metering jet orifice.

Primary throttle valves opened beyond off-idle range allows more air to enter the manifold which increases air velocity in the venturi. This causes a drop in pressure in the large venturi and a much greater drop in pressure in the small venturi. Low pressure in the small boost venturi causes air fuel to flow from the main discharge nozzle.

Fuel flows from the float bowl through the main fuel well metering jets into the main fuel well. The fuel in the main fuel well is mixed with air from the main well air bleeds then passes through the main discharge nozzles into the boost venturi.

The fuel mixture is combined with air in the boost venturi into a combustible mixture and passes through the throttle hoses.

**CAUTION:** *An adjustable part throttle feature is incorporated in all carburetors. This adjustment is made at the factory and no attempt should be made to adjust it in the field.*

The adjustable part throttle features a power piston with a pin pressed into it, which protrudes through the float bowl and gasket and contacts the adjustable link in the throttle body. The primary main metering rods have a double taper on the metering tip and can be identified by the suffix "B" stamped after the diameter on the rod. The purpose

of this feature is to give improved control of fuel during the main metering range.

Two calibrated holes, one in each primary bore are located just above the choke valve and feed fuel from the float bowl. During high carburetor air flows, low pressure created in the air horn bore pulls fuel from the high speed fuel feeds, supplementing fuel flow from the main metering system. The pull over enrichment system begins to feed fuel at approximately 8 lbs. of air per minute, and continues to feed at higher engine speeds to provide extra fuel necessary for good engine performance.

## POWER SYSTEM (FIGURE 5)

The power system in the Quadrajet carburetor provides an extra mixture under heavy acceleration or high speed operation. The richer mixture is supplied through the main metering system in the primary and secondary sides of the carburetor.

The power system located in the primary side consists of a spring loaded power piston located in a cylinder which is exposed to manifold vacuum. The spring loaded power piston tends to push upward against manifold vacuum.

On part throttle and cruising ranges, manifold vacuum is sufficient to hold the power piston down against spring tension so that the larger diameter of the metering rod tip is held in the main metering jet orifice. When engine load is increased to a point where an extra rich mixture is required, the spring tension overcomes the vacuum pull on the power piston and the tapered primary metering rod tip moves upward in the main metering jet orifice. The smaller diameter of the metering rod tip allows more fuel to pass through the main metering jet and enrich the mixture flowing into the primary main wells and out the main discharge nozzles. When the engine

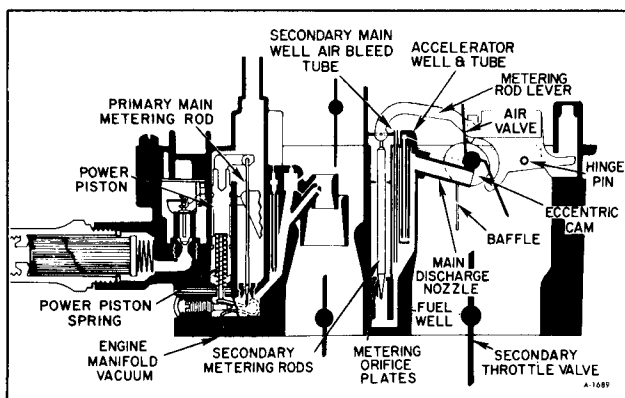

Figure 5—Power System

operation is returned to part throttle and cruising ranges, increased manifold vacuum overcomes the power piston spring and returns the larger portion of the metering rod into the metering jet orifice giving a leaner mixture.

When engine speed is increased to a point where the primary side of the carburetor cannot supply sufficient air and fuel requirements, the secondary side of the carburetor is used.

The secondary throttle valves are actuated by a connecting linkage to the primary throttle lever. With the throttle valves opened, a low pressure (vacuum) is created beneath the air valve. Atmospheric pressure on top of the offset spring loaded air valve forces the valve open allowing the required air to flow through the throttle bores to meet engine demands.

As the air valve opens, the upper edge passes the accelerating well port causing a low pressure (vacuum) at that point. Fuel starts flowing immediately and continues to flow until the well is empty.

The fuel from the accelerating ports prevents a momentary hesitation and provides an immediate charge of fuel until air/fuel begins to flow from the secondary discharge nozzles.

The secondary main discharge nozzles (one for each secondary bore) are located just below the air valve and above the secondary throttle valves in the area of lowest pressure. As the air valve opens, it rotates a plastic cam attached to the center of the main air valve shaft. The cam lifts a lever attached to the secondary main metering rods out of the secondary orifice discs. Fuel flows from the float bowl through the secondary orifice discs into secondary main wells, where it is mixed with air from the secondary main well air bleed tubes. The air/fuel mixture travels from the main wells to the secondary discharge nozzles and is expelled into the secondary bores. The air/fuel mixture is mixed with more air traveling through the secondary bores and combined with the air/fuel mixture delivered from the primary bores enters the engine cylinders as a combustible mixture.

As the secondary throttle valve is opened further, the increase in air flow through the throttle bores opens the air valve which rotates the eccentric cam lifting the tapered secondary metering rods further out of the metering orifice discs, increasing fuel flow in direct portion to air passing through the secondary throttle bores. By using this principle a correct air/fuel ratio can be maintained throughout the operation of the secondary side of the carburetor.

A baffle plate is used in each secondary bore extending up and around the secondary fuel dis-

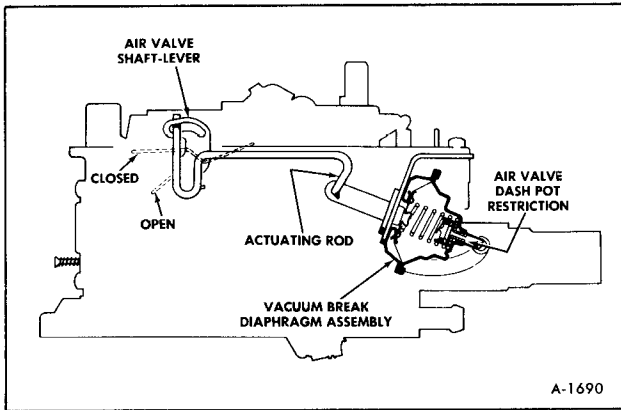

Figure 6—Air Valve Dashpot

charge nozzles. Their purpose is to provide good fuel distribution at lower air flows by preventing too much fuel from going to the front of the engine.

The depth of the main metering rods in the orifice discs in relation to the air valve position are factory adjusted to meet the air/fuel requirements for the specific engine model. No further adjustment should be required.

### AIR VALVE DASHPOT (FIGURE 6)

The secondary air valve is connected to the vacuum break unit by a rod, to control the opening rate of the air valve and prevent any fuel lag from the secondary discharge nozzle.

Whenever manifold vacuum is above 5" to 6" vacuum, the vacuum break diaphragm stem is seated and pulls the rod to the end of the slot in the air valve shaft lever, holding the air valve closed. However, when the secondary valves are opened and manifold vacuum drops below 5" to 6" vacuum, the spring in the vacuum break unit will force the diaphragm off its seat and allow the air valve to open. The rate of movement of the air valve spring is controlled by a restriction in the internal check valve in the vacuum break unit.

### ACCELERATING PUMP SYSTEM (FIGURE 7)

During quick acceleration when the throttle valves are opened rapidly, the sudden increase in air flow passing the fuel discharge nozzles tends to leave the fuel behind, which is heavier, causing a momentary leanness. The accelerator pump provides an additional charge of fuel during this time.

The accelerating pump system is located in the primary side of the carburetor consisting of a spring loaded pump plunger and pump return spring, located in the pump bore. The pump plunger is operated by a pump lever on the air horn which is connected directly to the throttle lever by a pump rod.

As the throttle is returned from an open to a closed position, the pump return spring pushes the pump plunger upward against the pump lever. As the pump begins to move up, the discharge check ball immediately seats in the pump discharge passage so that no air will be drawn into the passage, which could cause a hesitation. The pump well is always filled with fuel from the float bowl through a slot in the top of the pump well which is lower than the fuel level. When the pump plunger moves up, the floating pump cup unseats (moves down) from the flat surface on the plunger head and allows free flowing of fuel through the inside of the cup into the bottom of the pump well. This also vents any vapors which may be in the bottom of the pump well so that a solid charge of fuel can be maintained in the fuel well. When the primary throttle valves are opened, the connecting linkage forces the pump plunger down instantly seating the pump cup against the plunger forcing fuel through the discharge passage unseating the discharge check ball. The fuel is then forced up through a passage to the pump jets located in the air horn and sprayed into the venturi area of each primary bore.

It should be noted that the pump plunger is spring loaded. The top pump duration spring is calibrated so as to deliver a smooth charge of fuel from the pump jets by applying a pressure on the fuel that remains constant through pump travel regardless of speed or distance the throttle linkage is moved. When the throttle valves are opened instantly to wide open position, the spring loaded plunger will continue to supply fuel until the plunger reaches the

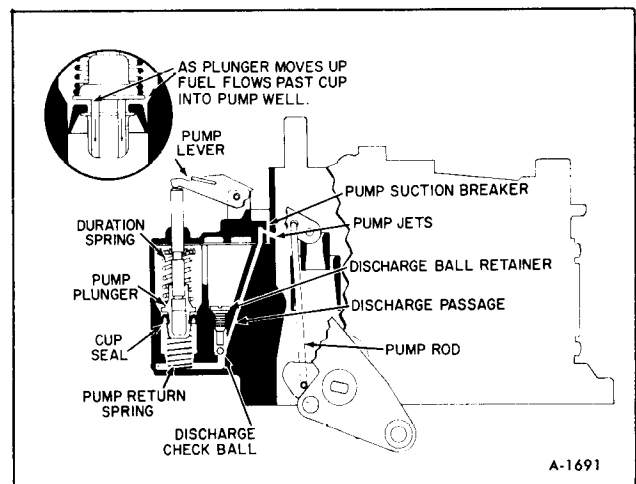

Figure 7—Accelerating Pump System



bottom of the pump well insuring an adequate fuel supply until the fuel starts to flow from the main discharge nozzle.

Due to vacuum at the pump jets during high speed operation, the pump discharge passage has been vented to the top of the air horn, outside the carburetor bores to balance the air pressure on the fuel in the pump discharge passage with the fuel in the float bowl. This prevents fuel from being pushed out of the pump jets when the pump is not in use.

## CHOKE SYSTEM (FIGURE 8)

The choke system consists of a choke valve, a vacuum break diaphragm, a choke housing and coil located on the side of the float bowl, fast idle cam, connecting linkage and air valve lockout lever. The thermostatic coil holds the choke valve closed when the engine is cold. Opening the throttle valves allows the choke to close and move the fast idle cam to the high step. When the choke valve is closed, the air valve lockout lever keeps the air valve closed.

During engine cranking, the choke valve is held closed by the tension of the thermostatic coil. This restricts air flow through the carburetor to provide a richer starting mixture. When the engine starts, manifold vacuum applied to the vacuum diaphragm opens the choke valve to a point where the engine will run without loading or stalling. The vacuum diaphragm unit has an internal bleed check valve which delays the diaphragm action a few seconds before it becomes seated allowing the engine manifold to be wetted and engine friction to decrease so that when the vacuum break point is reached, the engine will run without loading or stalling. When the choke valve moves to the vacuum break position, the fast idle cam follower will drop from the high step on the fast idle cam to the next lower step when the

throttle is opened. This gives the engine sufficient fast idle speed and correct fuel mixture for running until the engine begins to warm up and heat the thermostatic coil in the choke housing. Engine vacuum pulls heat from the manifold heat stove into the choke housing and gradually relaxes choke coil tension which allows the choke valve to continue opening through inlet air pressure pushing on the off set choke valve. Choke valve opening continues until the thermostatic coil is completely relaxed, at which point the choke valve is wide open and the engine is thoroughly warm.

During the last few degrees of choke valve opening, a tang on the choke lever contacts the secondary air valve lockout lever and rotates the lever counter-clockwise so that the tang over the air valve will move completely away from the valve, allowing the air valves to open and operate.

The choke system is equipped with an unloader mechanism which is designed to partially open the choke valve, should the engine become loaded or flooded. To unload the engine the accelerator pedal must be depressed so that the throttle valves are held wide open. A tang on a lever on the choke side of the primary throttle shaft contacts the fast idle cam and through the intermediate choke shaft forces the choke valve slightly open. This allows extra air to enter the carburetor bores and pass on into the engine manifold and cylinders to lean out the fuel mixture so that the engine will start.

## CARBURETOR DIAGNOSIS

Before proceeding with carburetor diagnosis it should be noted that proper carburetor operation is dependent upon the following:

1. Fuel supply.
2. Linkage and emission control systems.
3. Engine compression.
4. Ignition system firing voltage.
5. Ignition spark timing.
6. Secure intake manifold.
7. Engine temperature.
8. Carburetor adjustments.

## ANY PROBLEMS IN THE ABOVE AREAS CAN CAUSE THE FOLLOWING:

1. No start or hard starting - (hot or cold)

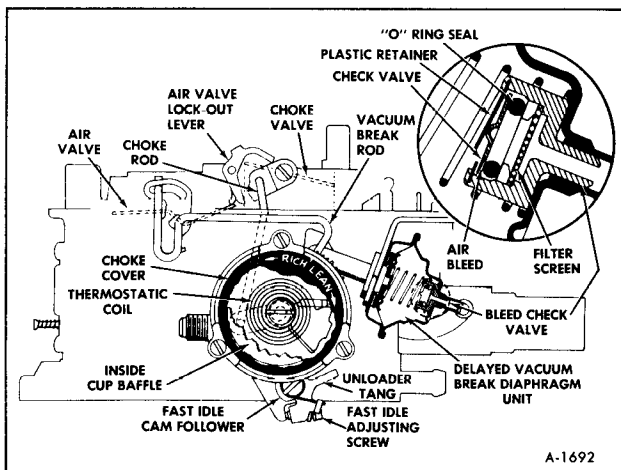

Figure 8—Choke System

- |  |                                  |
|--|----------------------------------|
| 2. Rough engine idle and stalling              | 5. Engine to run uneven or surge |
| 3. Hesitation on acceleration                  | 6. Poor fuel economy             |
| 4. Loss of power on acceleration and top speed | 7. Excessive emissions           |

## ENGINE CRANKS (TURNS OVER) WILL NOT START OR STARTS HARD WHEN COLD

Possible Cause	Corrective Action
Improper starting procedure used.	Check with the customer to determine if proper starting procedure is used, as outlined in the operating manual.
No fuel in gas tank.	Add fuel. Check fuel gauge for proper operation.
Choke valve not closing sufficiently when cold.	Adjust the choke thermostaic coil.
Choke valve or linkage binding or sticking.	Realign the choke valve or linkage as necessary. If caused by dirt and gum, clean with automatic choke cleaner. Do not oil choke linkage. If parts are replaced, check adjustments.
Vacuum leaks in carburetor base or intake manifold.	Check all manifold vacuum hoses for being connected and in proper location. Check manifold and carburetor base gaskets for leaks. Tighten or replace as necessary. Torque carburetor to manifold bolts to 15 ft. lbs.
No fuel in carburetor.	<ol style="list-style-type: none"> <li>1. Remove fuel line at carburetor. Connect hose to fuel line and run into metal container. Remove the high tension coil wire from center tower on distributor cap and ground. Crank over engine - if there is no fuel discharge from the fuel line, check for kinked or bent lines. Disconnect fuel line at tank and blow out with air hose, reconnect line and check again for fuel discharge. If none, replace fuel pump. Check pump for adequate flow.</li> <li>2. If fuel supply is o.k., check the following. <ol style="list-style-type: none"> <li>a. Inspect fuel filter. If plugged, replace.</li> <li>b. If filter are o.k., remove air horn and check for a bind in the float mechanism or a sticking float needle. If o.k., adjust float.</li> </ol> </li> </ol>

Possible Cause	Corrective Action
<p>Engine flooded. NOTE: To Check for flooding, remove air cleaner with engine off, and look into carburetor bores. Fuel will be dripping off discharge nozzles and carburetor bores will be very wet.</p>	<ol style="list-style-type: none"> <li>1. Check to determine if customer is using proper carburetor unloading procedure. Depress the accelerator to the floor and check carburetor to determine if the choke valve is opening. If not, adjust throttle linkage and unloader.</li> <li>2. If choke unloader is working properly - check for carburetor flooding. NOTE: Before removing the carburetor air horn, use the following procedure which may eliminate the flooding. Remove the fuel line at carburetor and plug. Start and run the engine until the fuel bowl runs dry. Turn off engine and connect fuel line. Then restart and run engine. This will usually flush dirt past the carburetor float needle and seat.</li> <li>3. If dirt is in the fuel system, clean the system and replace fuel filter as necessary. If excessive dirt is found, remove the carburetor unit. Disassemble and clean.</li> <li>4. Check float needle and seat for proper seal. If a needle and seat tester is not available, apply mouth suction needle seat with needle installed. If needle and seat is defective, replace with factory matched set.</li> <li>5. Check float for being loaded with fuel, bent float arm or binds in the float hanger. Free up or replace parts as necessary. NOTE: A solid float can be checked for fuel absorption by lightly squeezing between fingers. If wetness appears on surface or float feels heavy (check with known good float), replace float assembly.</li> <li>6. After making preceding checks, adjust float assembly.</li> </ol>

## ENGINE STARTS AND STALLS

Possible Cause	Corrective Action
<p>Engine does not have enough fast idle speed when cold.</p>	<p>Check and reset fast idle screw and fast idle cam.</p>
<p>Choke vacuum break unit is not adjusted to specification or is defective.</p>	<ol style="list-style-type: none"> <li>1. Adjust choke vacuum break assembly to specifications.</li> <li>2. If adjusted O.K., check the vacuum break unit for proper operation as follows. Connect a piece of hose to the nipple on the vacuum break unit and apply suction by mouth or vacuum source. Diaphragm plunger should move inward and hold vacuum. If not, replace diaphragm unit. NOTE: Always check fast idle cam (choke rod) adjustment first before adjusting vacuum break unit.</li> </ol>

Possible Cause	Corrective Action
Choke coil rod out of adjustment.	Adjust choke coil rod.
Choke valve and/or linkage sticking or binding.	<ol style="list-style-type: none"> <li>1. Clean and align choke valve and linkage. Replace if necessary.</li> <li>2. Re-adjust if part replacement is necessary.</li> </ol>
Idle speed setting.	Adjust idle speed to specifications on decal in engine compartment.
Not enough fuel in carburetor.	<ol style="list-style-type: none"> <li>1. Test fuel pump pressure and volume, as outlined in service manual.</li> <li>2. Check for partially plugged fuel inlet filter. Replace, if dirty.</li> <li>3. Check fuel tank lines and tank vent lines for being open. Clean as necessary.</li> <li>4. Remove air horn and check float adjustment.</li> </ol>
Carburetor flooding  NOTE: Check for flooding by using procedure outlined under "Engine cranks - will not start - engine flooded" Page 1.	<ol style="list-style-type: none"> <li>1. Check all fuel filters for dirt. Clean and replace as necessary.</li> <li>2. If carburetor still floods, remove air horn and check float needle and seat for proper seal. If a needle seat tester is not available, mouth suction can be applied to the needle seat with needle installed. If needle seat leaks, replace with a factory matched set.</li> <li>3. Check float for being loaded with fuel, bent float arms or binds in float hanger. NOTE: A solid float can be checked for fuel absorption by lightly squeezing between fingers. If wetness appears on surface or float feels heavy (check with known good float), replace float assembly.</li> <li>4. Check float adjustments.</li> <li>5. If excessive dirt is found in the carburetor, clean fuel system and carburetor.</li> </ol>

## ENGINE IDLES ROUGH AND STALLS

Possible Cause	Corrective Action
Idle speed setting.	Re-set idle speed per instructions on decal in engine compartment.
Manifold vacuum hoses disconnected or improperly installed.	Check all vacuum hoses leading into the manifold or carburetor base for leaks or being disconnected. Install or replace as necessary.
Carburetor loose on intake manifold.	Torque carburetor to manifold bolts (to 15 ft. lbs.).

Possible Cause	Corrective Action
Intake manifold is loose or gaskets are defective.	Using a pressure oil can, spray light oil or kerosene around manifold legs and carburetor base. If engine RPM changes, tighten or replace the manifold gaskets or carburetor base gaskets as necessary.
Hot idle compensator not operating (where used).	Normally the hot idle compensator should be closed when engine is running cold and open when engine is hot (approx. 140°F at comp.) replace if defective.
Air leaks into carburetor idle channels.	Tighten all carburetor screws. If gaskets are hard or cracked, replace as necessary.
Poor secondary throttle valve alignment.	If mis-aligned, loosen screws, align valves, tighten screws and re-stake as necessary.
Carburetor flooding. NOTE: Check by using procedure outlined under engine flooded. Page 1.	<ol style="list-style-type: none"> <li>1. Remove air horn and check float adjustments.</li> <li>2. Check float needle and seat for proper seal. If a needle seat tester is not available, mouth suction can be applied to the needle seat with needle installed. If needle and seat are defective, replace with factory matched set.</li> <li>3. Check float for being loaded with fuel, bent float arm or binding float hanger.</li> </ol> <p>NOTE: A solid float can be checked for fuel absorption by lightly squeezing between fingers. If wetness appears on surface or float feels heavy (check with known good float), replace float assembly.</p>
Dirt in idle channels.	If excessive dirt is found in carburetor or idle channels, clean fuel system and carburetor. Replace fuel filter as necessary.

## ENGINE HESITATES ON ACCELERATION

Possible Cause	Corrective Action
Defective accelerator pump system. NOTE: A quick check of the pump system can be made as follows. With the engine off, remove air cleaner and look into carburetor bores and observe pump shooters, while briskly opening throttle valves. A full stream should emit from each pump jet and enter the center of the carburetor bore.	<ol style="list-style-type: none"> <li>1. Remove carburetor air horn and check pump cup. If cracked, scored or distorted, replace pump plunger. Check pump discharge ball for proper seating and location.</li> </ol> <p>To check discharge ball for proper seating, fill cavity above discharge ball with fuel. If "leak down" occurs remove discharge ball and clean check ball seat and pump passages and jets. If clean, stake discharge ball seat by tapping ball lightly against seat with drift punch and small hammer. Replace with new discharge ball.</p>

Possible Cause	Corrective Action
Dirt in pump passes or pump jet.	Clean and Blow out with compressed air.
Float level	Check for sticking float needle or binding float. Free up or replace parts as necessary. Check and reset float level to specification.
Leaking air horn to float bowl gasket.	Torque air horn to float bowl using proper tightening procedure.
Carburetor loose on manifold.	Torque carburetor to manifold bolts (to 15 ft. lbs.).
Air valve binding (sticks open)	1. Torque air horn screws evenly using proper tightening sequence. 2. Free-up air valve shaft and align air valves. 3. Check air valve spring for closing tension. If defective, replace with spring kit part number 7035344.
Secondary throttle valve lockout.	1. Free-up and check for proper operation. 2. Adjust secondary throttle valve lockout.

## NO POWER ON HEAVY ACCELERATION OR AT HIGH SPEED

Possible Cause	Corrective Action
Carburetor throttle valve not going wide open. (Check by pushing accelerator pedal to floor	Adjust throttle linkage to obtain wide open throttle in carburetor.
Dirty or plugged fuel filter.	Replace as necessary.
Secondary throttle valves not unlocking after engine warms up.	Free-up and adjust secondary throttle lockout.
Air valves binding, stuck closed or wide open.	1. Free-up air valve shaft and align air valves. 2. Torque air horn screws evenly using proper tightening sequence. 3. Check air valve spring for closing tension. If defective, replace with spring kit, part number 7035344.
Power system not operating.	1. Check power piston for free up and down movement. Proceed as follows. Use a .300 plug gauge or 19/64" drill and insert in front air horn vent stack. Push gently downward on top of power piston with engine off. Power piston should move downward approximately 1/4" and return to up position under spring tension. If power piston is sticking, remove the carburetor air horn and check power piston and cavity for dirt or scores. Check power piston spring for distortion.

Possible Cause	Corrective Action
Float level too low.	Check and reset float level.
Float not dropping far enough in bowl.	Check for bind in float hanger and float arm, float alignment in bowl and needle pull clip for sufficient clearance on float arm.
Main metering jets or metering rods dirty, plugged or incorrect part.	<ol style="list-style-type: none"> <li>1. If the main metering jets are plugged or dirty or excessive dirt is in fuel bowl, the carburetor should be completely disassembled and cleaned.</li> <li>2. If the jets or rods are incorrect size, consult the parts list for proper usage. The last two digits stamped on the primary rods and jets are the last two digits of the part number.</li> </ol>

## ENGINE STARTS HARD WHEN HOT

Possible Cause	Corrective Action
Choke valve not opening completely.	<ol style="list-style-type: none"> <li>1. Check for binding choke valve and/or linkage. Clean and/or replace as necessary. Do not oil choke linkage.</li> <li>2. Check and adjust choke thermostatic coil.</li> </ol>
Engine flooded, carburetor flooding.	See procedure under "Engine cranks, will not start engine flooded."
No fuel in carburetor.	<ol style="list-style-type: none"> <li>1. Check fuel pump. Run pressure and volume test.</li> <li>2. Check float needle for sticking in seat, or binding float.</li> <li>3. Check and adjust float level.</li> </ol>
Leaking float bowl.	Fill bowl with fuel and look for leaks.

## ENGINE RUNS UNEVEN OR SURGES.

Possible Cause	Corrective Action
Fuel restriction.	Check all hoses and fuel lines for bends, kinks or leaks. Straighten and secure in position. Check all fuel filters, if plugged or dirty - replace.
Dirt or water in fuel system.	Clean fuel tank, lines and filters. Remove and clean carburetor.
Fuel level.	Adjust float. Check for free float and float needle valve operation. Free up or replace as necessary.
Metering rods bent or incorrect part. Main metering jets dirty, defective, loose or incorrect part	Clean or replace as necessary.

Possible Cause	Corrective Action
Power system in carburetor not functioning properly. Power piston sticking.	Free up or replace as necessary.
Vacuum leakage.	It is absolutely necessary that all vacuum hoses and gaskets are properly installed with no air leaks. The carburetor and manifold should be evenly tightened to specified torque. Carburetor to manifold (to 15 ft. lbs.).
Secondary throttle valves sticking open or not seating properly.	Loosen secondary throttle valve screws. Align valves in carburetor bores and tighten securely.

## POOR FUEL ECONOMY

Possible Cause	Corrective Action
Engine needs complete tune up.	Check engine compression, examine spark plugs, (if dirty or improperly gapped, clean and re-gap or replace), ignition point dwell, condition, re-adjust ignition points if necessary and check and reset ignition timing. Clean or replace air cleaner element if dirty. Check for restricted exhaust system and intake manifold for leakage. Make sure all vacuum hoses are connected correctly.
Choke valve not fully opening.	<ol style="list-style-type: none"> <li>1. Clean choke and free-up linkage.</li> <li>2. Check choke coil for proper adjustment.</li> </ol>
Fuel leaks.	Check fuel tank, fuel lines and fuel pump for any fuel leakage.
High fuel level in carburetor or carburetor flooding.	<ol style="list-style-type: none"> <li>1. Check for dirt in the needle and seat. Test using suction by mouth or needle seat tester.</li> <li>2. Check for loaded float.</li> <li>3. Re-set carburetor float.</li> <li>4. If excessive dirt is present in the carburetor bowl, the carburetor should be cleaned.</li> </ol>
Power system in carburetor not functioning properly. Power piston sticking in up position.	Free-up or replace as necessary.
Metering rods bent or incorrect part. Main metering jets, defective, loose or incorrect part	Clean or replace as necessary.
Fuel being pulled from accelerator system into venturi through pump jets.	Run engine at RPM where nozzles are feeding fuel. Observe pump jets. If fuel is feeding from jets, check pump discharge ball for proper seating by filling cavity above ball with fuel to level of casting. No "leak down" should occur with discharge ball in place, Re-stake or replace leaking check ball
Air bleeds or fuel passages in carburetor dirty or plugged.	Clean carburetor or overhaul as necessary.



## CARBURETOR REPLACEMENT

### REMOVAL

1. Remove engine cover.
2. Remove air cleaner. Refer to "Air Cleaner" later in this section.
3. Disconnect vacuum hoses. Disconnect fuel inlet line.
4. Disconnect throttle cable. Disconnect cruise control rod if equipped.
5. Remove air cleaner stud.
6. Disconnect choke housing pipe.
7. Remove four (4) carburetor to manifold attaching bolts.
8. Remove carburetor.

### INSTALLATION

1. Install a new carburetor to manifold gasket.
2. Install carburetor. Torque attaching bolts to 15 ft. lbs. in sequence as shown in Figure 10.
3. Connect choke housing pipe.
4. Install air cleaner stud.
5. Connect throttle cable. Connect cruise control rod if removed.
6. Connect vacuum lines. Connect fuel inlet line. Hold fuel inlet nut while connecting fuel line to avoid damaging inlet nut nylon gasket.
7. Install air cleaner.
8. Install engine cover.

### CARBURETOR OVERHAUL

**NOTE:** Before performing any service on the carburetor it is essential that the carburetor be placed on a holding fixture. The secondary throttle valves in the wide open position extend below the throttle body casting. Without the use of the carburetor fixture it is possible to bend or nick the aluminum throttle valves.

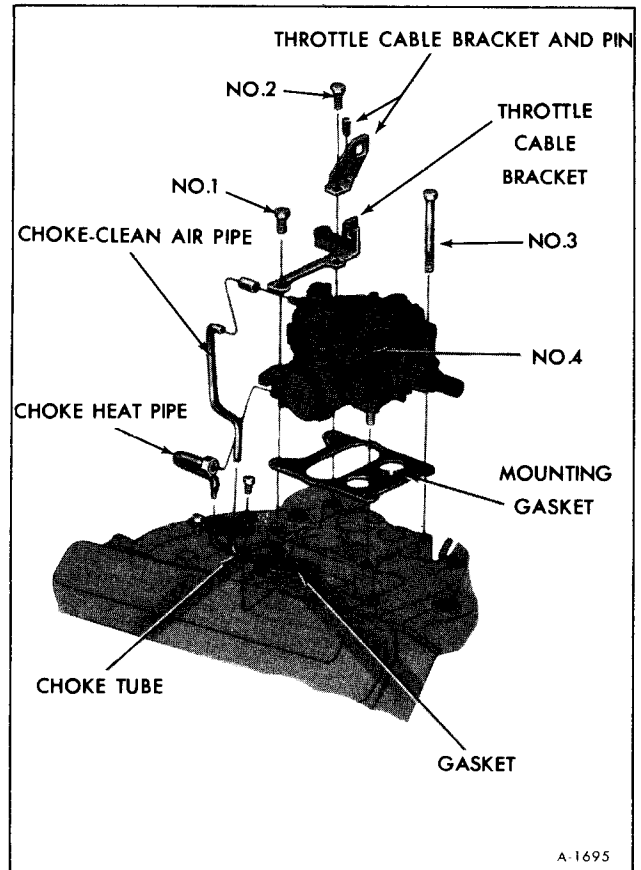

Figure 10—Carburetor Installation

### AIR HORN REMOVAL

1. Remove air cleaner assembly.

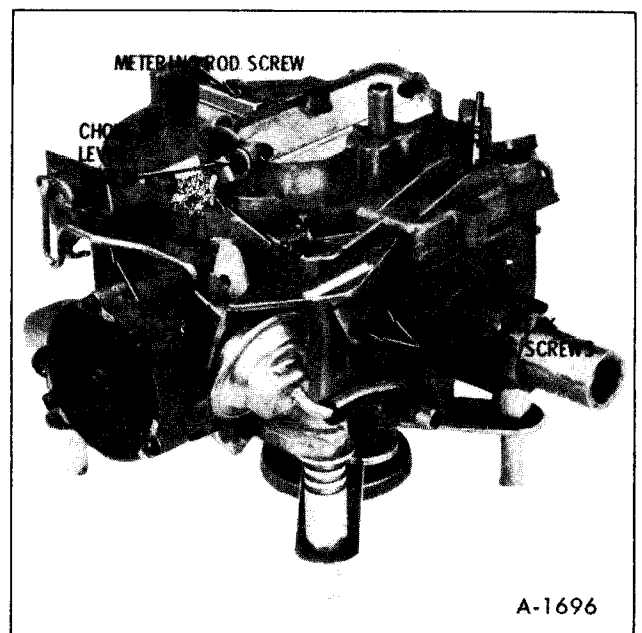

Figure 11—Carburetor Assembly

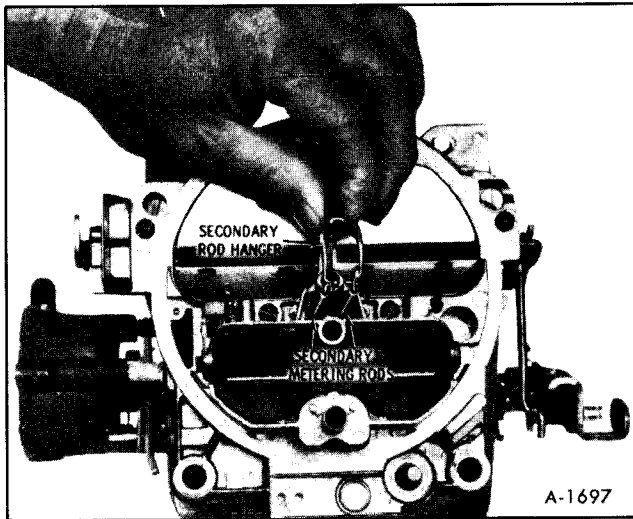

Figure 12—Secondary Metering Rods

2. Remove upper choke lever from the end of choke shaft by removing retaining screw (figure 11). Then remove the upper choke lever from the end of choke rod and choke rod from lower lever inside the float bowl casting.

**NOTE:** Remove rod by holding lower lever outward with small screwdriver and twisting rod counterclockwise.

3. Remove vacuum break hose, remove vacuum break bracket attaching screws. The diaphragm assembly may now be removed from the dashpot rod and the dashpot rod from the air valve lever.

4. Remove secondary metering rods by removing the small screw in the top of the metering rod hanger. Lift upward on metering rod hanger until the secondary metering rods are completely out of the air horn. Metering rods may be disassembled from the hanger by rotating ends out of the holes in the end of the hanger (See figure 12).

5. Remove nine air horn to bowl attaching screws; two attaching screws are located next to the primary venturi. (Two long screws, five short screws, two countersunk screws.) See Figure 13.

6. The air horn assembly may now be removed from the float bowl by opening the throttle valve wide open and lifting up on the air horn and turning sideways until the pump rod disengages from the upper pump lever as shown in Figure 14.

**CAUTION:** Care must be taken not to bend the small bleed tubes and accelerating tubes in air horn casting. These are permanently pressed into casting. Do Not Remove.

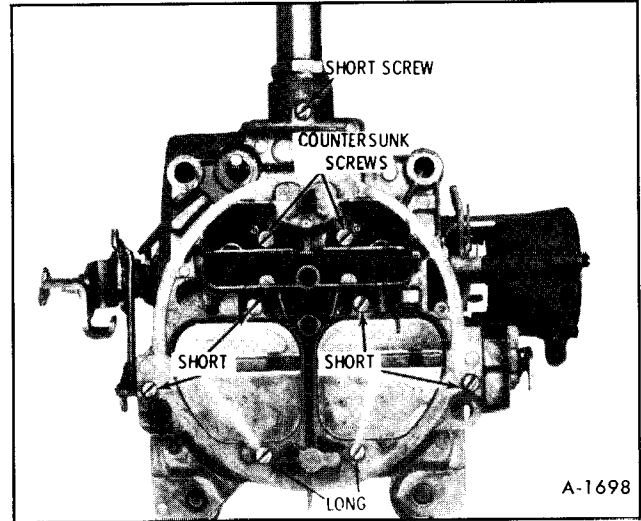

Figure 13—Air Horn Attaching Screws

## AIR HORN DISASSEMBLY

Further disassembly of the air horn is not recommended for cleaning purposes. If part replacement is required, proceed as follows:

1. Remove choke valve attaching screws, then remove choke valve and shaft from air horn.

**NOTE:** Air valves and air valve shaft should not be removed. However, if it is necessary to replace the air valve closing spring or center plastic eccentric cam, a repair kit is available. Instructions for assembly are included in the repair kit.

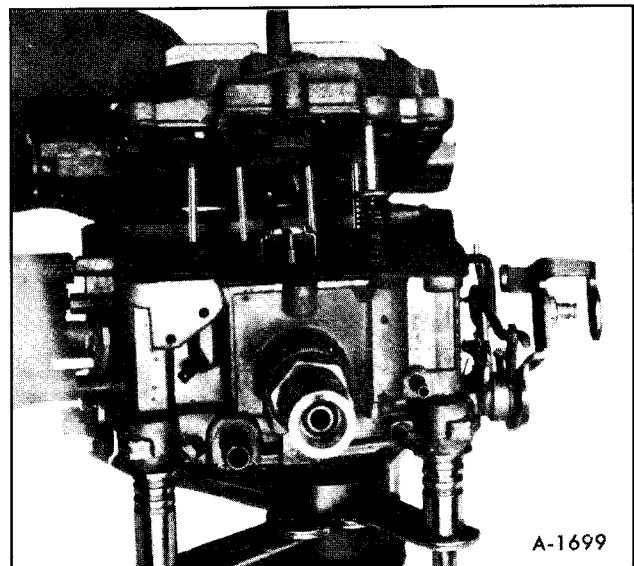

Figure 14—Removing Air Horn

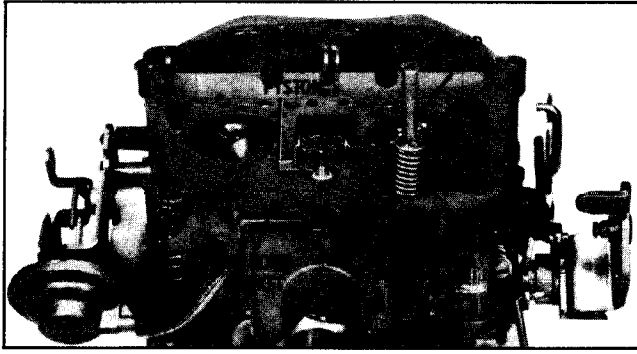

Figure 15-Float Bowl Assembly

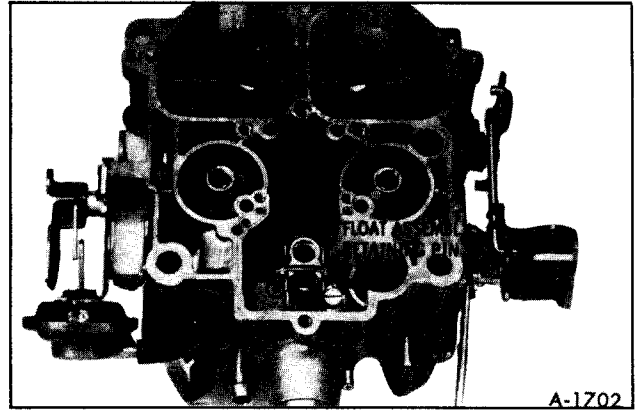

Figure 17-Float Assembly

### FLOAT BOWL DISASSEMBLY

1. Remove pump plunger from pump well. See Figure 15.
2. Remove air horn gasket from float bowl.
3. Remove pump return spring from pump well.
4. Remove plastic filler over float valve.
5. Remove power piston and primary metering rods by depressing piston stem and allowing it to snap free. Remove power piston spring from well.

**NOTE:** Piston may require several snaps to come free.

6. Remove metering rods from power piston by disconnecting tension spring from top of each rod then rotating rod to remove from hanger as shown in Figure 16.

7. Remove float assembly and float needle by pulling up on retaining pin. Remove float needle seat and gasket (figure 17).

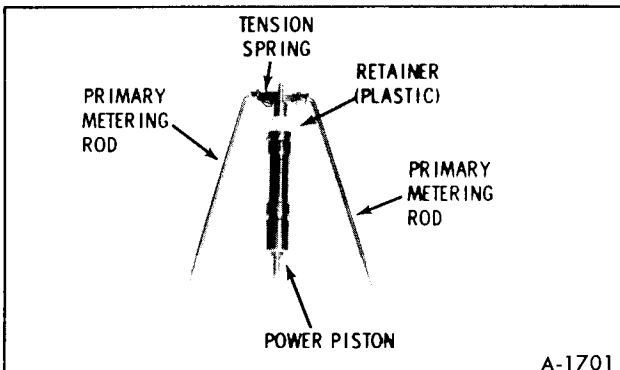

Figure 16-Power Piston and Metering Rod

8. Remove primary metering jets. No attempt should be made to remove secondary metering plates (figure 18).

9. Remove pump discharge check ball retainer and check ball.

10. Remove baffle from secondary side of bowl.

**CAUTION:** Do not place vacuum break assembly in carburetor cleaner. Remove choke assembly. If further disassembly is necessary, spread the retaining ears on bracket next to vacuum break assembly, then remove vacuum break from bracket.

### CHOKE DISASSEMBLY

1. Remove three retaining screws and retainers from choke cover and coil assembly. Then pull straight outward and remove cover and coil assembly from choke housing. See Figure 19.

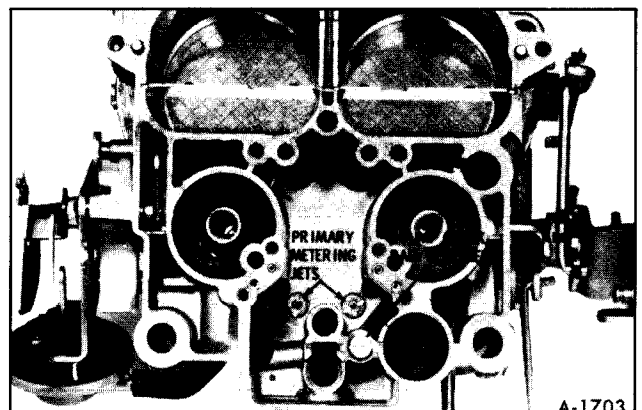

Figure 18-Primary Metering Jets

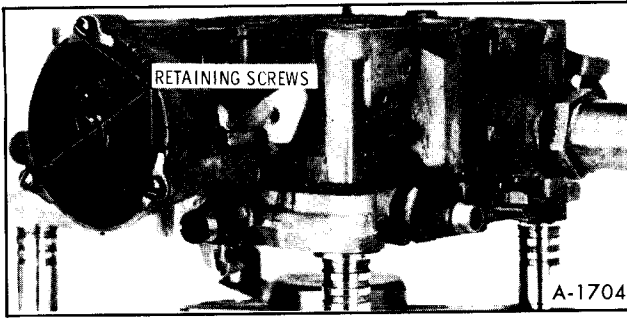

Figure 19—Choke Housing

**NOTE:** It is not necessary to remove baffle plate beneath the thermostatic coil. Distortion of the thermostatic coil may result if forced off the center retaining post on the choke cover.

2. Remove choke housing assembly from float bowl by removing retaining screw and washer inside the choke housing (figure 20). The complete choke assembly can be removed from the float bowl by sliding outward. Remove plastic tube seal from choke housing. Remove lower choke lever from inside float bowl cavity by inverting bowl.

**CAUTION:** *Plastic tube seal should not be immersed in carburetor cleaner.*

3. To disassemble intermediate choke shaft from choke housing, remove coil lever retaining screw at end of shaft inside the choke housing (figure 21). Then remove thermostatic coil lever from flats on intermediate choke shaft. Remove intermediate choke shaft from the choke housing by sliding outward. The fast idle cam can now be removed from the intermediate choke shaft. See Figure 22.

**CAUTION:** *Remove the cup seal from inside choke housing shaft hole, if the housing is to be immersed in carburetor cleaner. Also,*

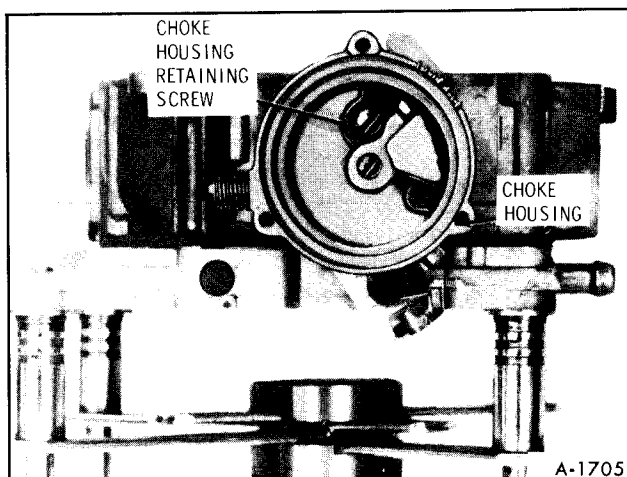

Figure 20—Choke Housing Attachment

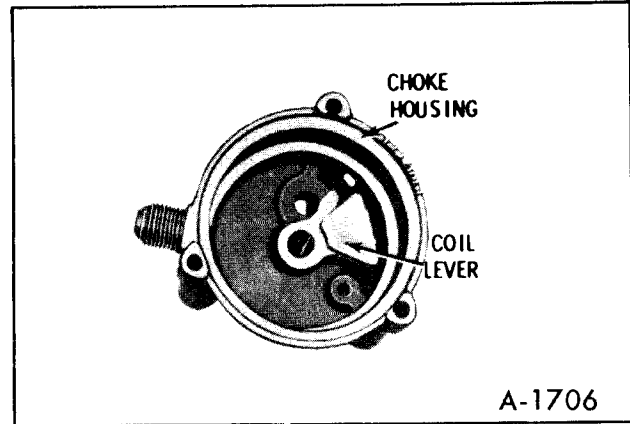

Figure 21—Choke Coil Lever

*remove the cup seal from the float bowl plastic insert for bowl cleaning purposes. Do not attempt to remove plastic insert.*

## DISASSEMBLY OF REMAINING FLOAT BOWL PARTS

1. Remove fuel inlet nut, gasket and filter. See Figure 23.

2. Remove throttle body by removing throttle body to bowl attaching screws as shown in Figure 24.

3. Remove throttle body to bowl insulator gasket. See Figure 25.

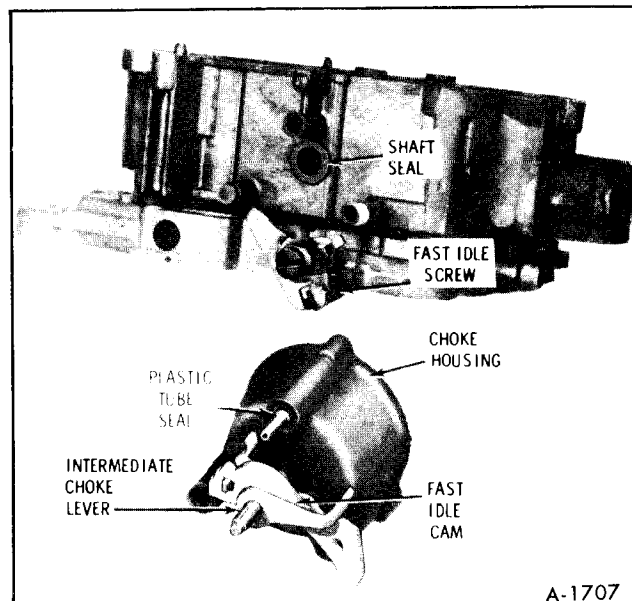

Figure 22—Choke Housing Sealing

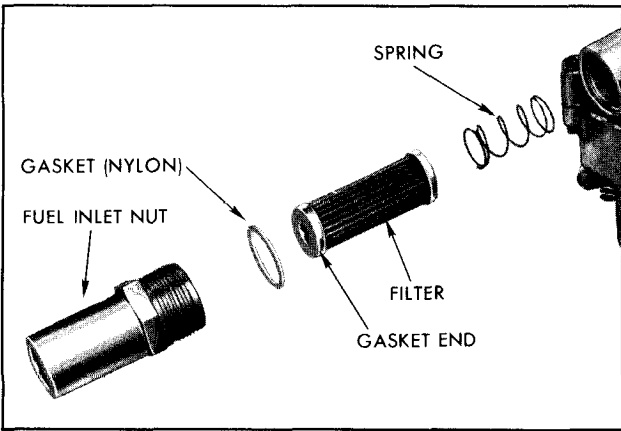

Figure 23-Fuel Filter

### THROTTLE BODY DISASSEMBLY

1. Remove pump rod from throttle lever.
2. **DO NOT REMOVE** idle mixture limiter caps, unless it is necessary to replace the mixture needles or normal soaking and air pressure fails to clean the idle passages. If the idle mixture needles are removed, adjustment procedures will be covered in the "Carburetor ——— Adjustment" chart. If necessary to remove the idle mixture needle, destroy plastic limiter cap. Do not install a replacement cap as a bare mixture screw is sufficient to indicate that the mixture has been readjusted.

### CLEANING AND INSPECTION

1. Thoroughly clean carburetor castings and metal parts in an approved carburetor cleaner.

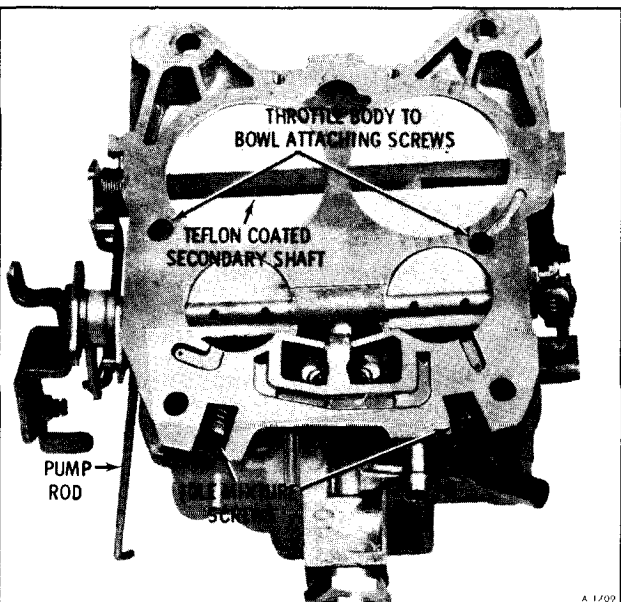

Figure 24-Throttle Body Attaching Screws

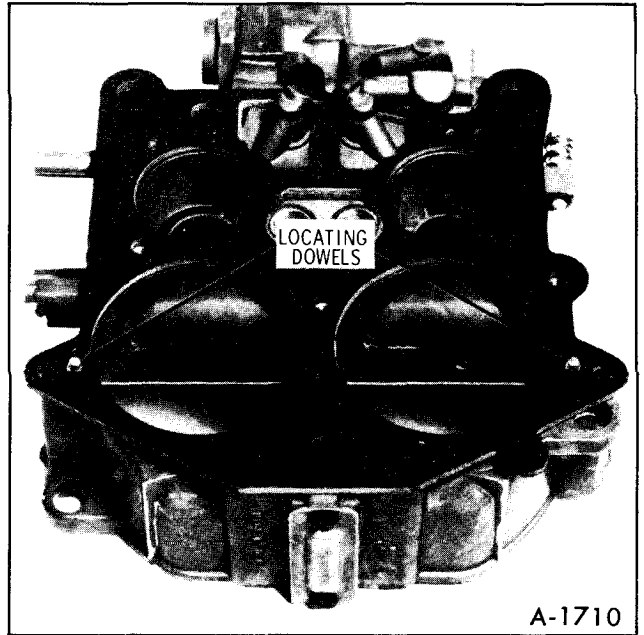

Figure 25-Throttle Body Gasket

**CAUTION:** *Rubber parts, plastic parts, and pump plungers should not be immersed in carburetor cleaner. However, the delrin cam on the air valve shaft and the throttle valve shafts will withstand normal cleaning in carburetor cleaner.*

2. Blow out all passages in castings with compressed air.

**CAUTION:** *Do not pass drills through jets or passages.*

3. Examine float needle and seat for wear. Replace if necessary with float needle assembly.
4. Inspect upper and lower surfaces of carburetor castings for damage.
5. Inspect holes in levers for excessive wear or out of round conditions. If worn, levers should be replaced.
6. Examine fast idle cam for wear or damage.
7. Check air valve for binding conditions. If air valve is damaged air horn assembly must be replaced.
8. Check all throttle levers and valves for binds or other damage.

### THROTTLE BODY

1. If removed, install idle mixture needles and

springs until seated. Back out the mixture needles six turns as a preliminary idle adjustment. Final adjustment must be made on the engine using the procedure described under slow idle adjustment.

2. Install lower end of pump rod in throttle lever by aligning tang on rod with slot in lever. End of rod should point outwards towards throttle lever.

## FLOAT BOWL ASSEMBLY

1. Install new throttle body to bowl gasket over two locating dowels on the bowl as shown in Figure 25.

2. Install throttle body making certain throttle body is properly located over dowels on float bowl then install throttle body to bowl screws and tighten evenly and securely. See Figure 24.

3. Install fuel inlet filter spring, new gasket and inlet nut and tighten nut securely (18 ft. lbs.) as shown in Figure 23.

**CAUTION:** *Tightening beyond specified torque can damage nylon gasket.*

## CHOKE HOUSING ASSEMBLY TO FLOAT BOWL

1. Install new cup seal into plastic insert on side of float bowl for intermediate choke shaft. Lip on cup seal faces outward.

2. Install fast idle cam onto the intermediate choke shaft (steps on fast idle cam face downward) as shown in Figure 22.

3. Install new rubber cup seal inside choke housing. Lips on seal face inward, towards inside of housing.

4. Carefully install fast idle cam and intermediate choke shaft assembly through seal in choke housing; then install thermostatic coil lever onto flats on intermediate choke shaft. Inside thermostatic choke coil level is properly aligned when both inside and outside levers face towards fuel inlet. Install inside lever retaining screw into end of intermediate choke shaft. Tighten securely.

5. Install lower choke rod lever into cavity in float bowl. Install plastic tube seal into cavity on choke housing before assembling choke housing to bowl. Install choke housing to bowl sliding inter-

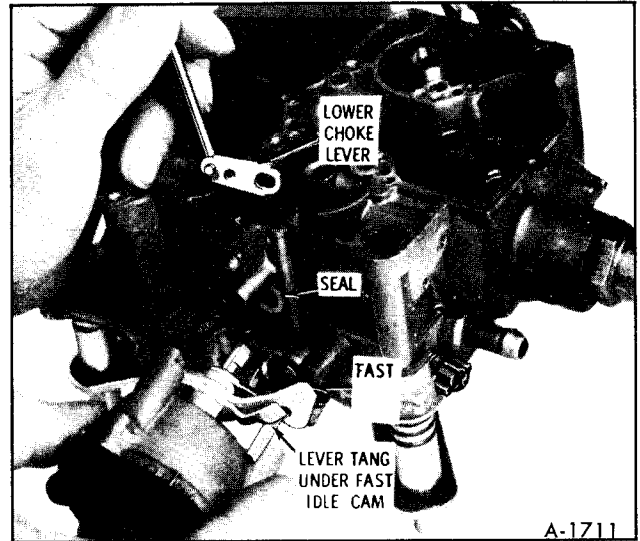

Figure 26—Lower Choke Lever

mediate choke shaft into lower choke lever. See Figure 26.

6. Install choke housing retaining screw and washer and tighten securely.

**NOTE:** The intermediate choke shaft lever and fast idle cam are in correct relation when the tang on lever is beneath the fast idle cam. Do not install choke cover and coil assembly until inside coil lever is adjusted. See On Vehicle Adjustment Chart (figure 9).

## COMPLETION OF FLOAT BOWL ASSEMBLY

1. Install baffle in secondary side of float bowl with notches toward top of bowl.

2. Install pump discharge check ball and retainer in passage next to pump well. Tighten retainer securely.

3. Install primary metering jets. See Figure 18.

4. Install new needle seat assembly.

**NOTE:** To make adjustment easier, bend float arm upward at notch in arm before assembly.

5. Install float by sliding float lever under pull clip from front to back. With float lever in pull clip, hold float assembly at toe and in tall retaining pin from pump well side.

**NOTE:** Do not install float needle pull clip into holes in float arms.

## 6. Float level adjustment:

a. With adjustable T-scale, measure from top of float bowl gasket surface (gasket removed) to top of float at toe/locate gauging point 1/16" back from toe.

Make sure float retainer is held firmly in place and arm of float is seated on float needle.

b. Bend float arm as necessary for proper adjustment by pushing on pontoon. Refer to adjustment chart for specification.

7. Install power piston spring into power piston well. If primary main metering rods were removed from hanger, re-install making sure that tension spring is connected to top of each rod (figure 16). Install power piston assembly in well with metering rods properly positioned in metering jets. Press down firmly on plastic power piston retainer to make sure the retainer is seated in recess in bowl and the top is flush with the top of the bowl casting.

8. Install plastic filler block over float needle, pressing downward until properly seated.

9. Install pump return spring in pump well.

10. Install air horn gasket around primary main metering rods and piston. Position gasket over two dowels on secondary side of bowl.

11. Install pump plunger in pump well.

## AIR HORN ASSEMBLY

1. If removed, install choke shaft, choke valve and two attaching screws. Tighten screws securely and stake lightly in place.

## AIR HORN TO BOWL INSTALLATION

1. Holding the primary throttle valves wide open, rotate the air horn assembly so that the pump rod slides into hole in pump lever and then carefully lower air horn assembly onto the float bowl. Make sure that the bleed tubes and accelerating well tubes are positioned properly through the holes in the air horn gasket. Do not force the air horn assembly onto the bowl, but rather lightly lower in place.

2. Install two long air horn screws, five short screws, and two countersunk screws into primary venturi area. All screws must be tightened evenly and securely. See Figure 27.

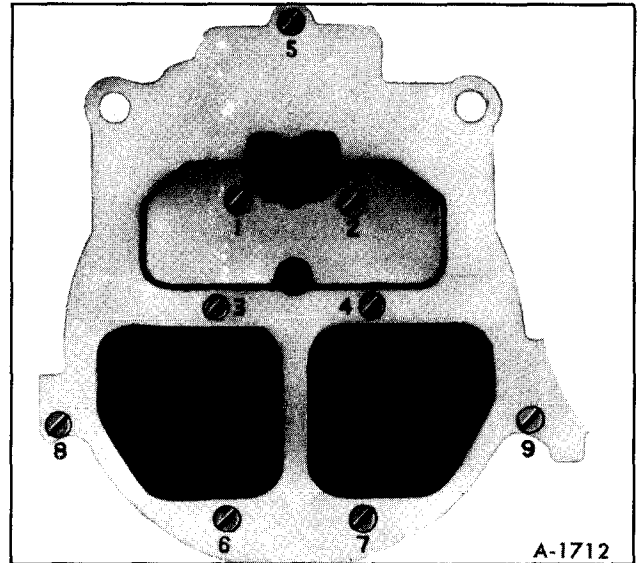

Figure 27—Air Horn Tightening Sequence

3. Install vacuum break diaphragm combination rod into the slot in lever on the end of the air valve shaft. Then install the other end of rod into hole in the vacuum diaphragm plunger. Install vacuum diaphragm assembly to float bowl using two retaining screws through bracket. Tighten securely.

4. Install rubber hose between the vacuum diaphragm and vacuum tube on float bowl.

5. Connect choke rod into lower choke lever inside bowl cavity; then install upper end of rod into upper choke lever and retain the choke lever to the end of choke shaft with attaching screw. Tighten securely.

**NOTE:** Make sure that the flats on the end of the choke shaft align with flats in the choke lever.

6. Install the secondary metering rods to the secondary metering rod hanger. The ends of the secondary metering rods point inward. Lower secondary metering rods into float bowl cavity and place hanger on actuating lever. Install small retaining screw and tighten lightly and securely.

**NOTE:** The thermostatic coil lever inside the choke housing has to be indexed properly before installing the choke thermostatic coil cover baffle and gasket assembly. Refer to adjustment charts (figures 28, 29, 30 and 31) for adjustment information.

After the inside thermostatic coil lever is adjusted, the thermostatic coil, cover and gasket assembly should be installed and rotated counterclockwise until the choke valve just closes. At this point, the index cover should be set as shown on adjustment chart (Choke Coil Adjustment). Install three choke cover retainers and screws and tighten securely.

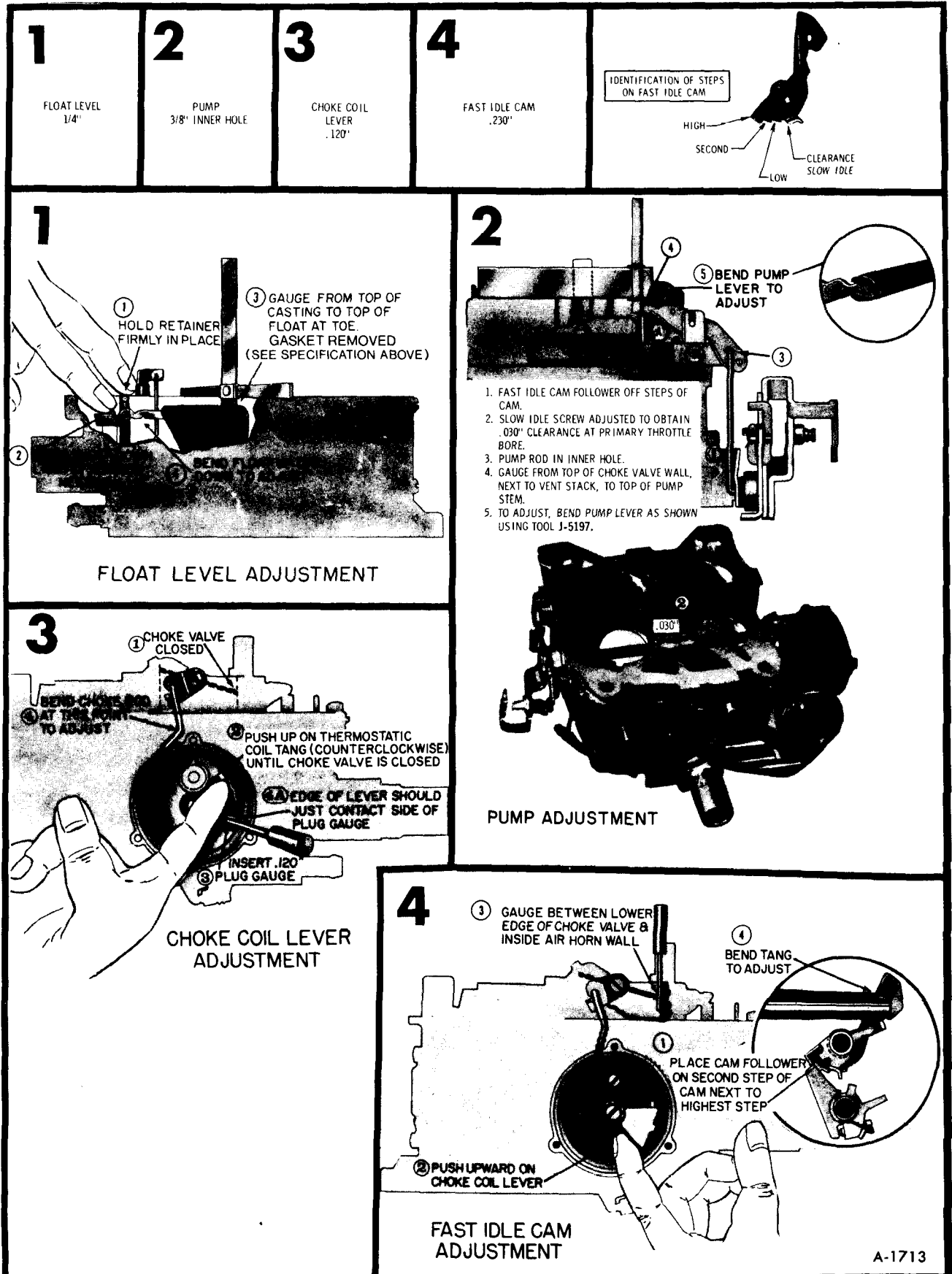

Figure 28—Carburetor Adjustments



<p><b>5</b></p> <p>AIR VALVE DASHPOT .050"</p>	<p><b>6</b></p> <p>CHOKE COIL ADJUSTMENT</p>	<p><b>7</b></p> <p>VACUUM BREAK (1973)—.215 (1974)—.275</p>	<p><b>8</b></p> <p>UNLOADER .300"</p>	<p><b>9</b></p> <p>AIR VALVE LOCKOUT .035"</p>	<p><b>10</b></p> <p>SECONDARY OPENING .070"</p>	<p>IDENTIFICATION OF STEPS ON FAST IDLE CAM</p>
<p><b>5</b></p> <p>AIR VALVE DASHPOT ADJUSTMENT</p>		<p><b>6</b></p> <p>CHOKE COIL ADJUSTMENT</p>				
<p><b>7</b></p> <p>VACUUM BREAK ADJUSTMENT</p>		<p><b>8</b></p> <p>UNLOADER ADJUSTMENT</p>				
<p><b>9</b></p> <p>AIR VALVE LOCKOUT ADJUSTMENT</p>		<p><b>10</b></p> <p>SECONDARY OPENING ADJUSTMENT</p>				

Figure 29—Carburetor Adjustments

**11** AIR VALVE SPRING

**12**  
SLOW IDLE  
SEE STEP 12 BELOW

**13**  
FAST IDLE  
SEE STEP 13 BELOW

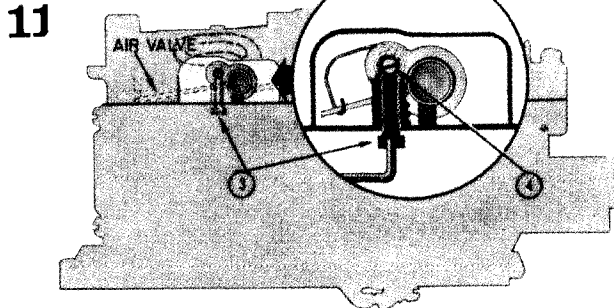

**AIR VALVE SPRING ADJUSTMENT**

1. REMOVE VACUUM BREAK DIAPHRAGM, AND ROD.
2. OPEN CHOKE VALVE.
3. LOOSEN LOCK SCREW (ALLEN HEAD).
4. TURN TENSION ADJUSTING SCREW COUNTER-CLOCKWISE UNTIL AIR VALVE OPENS PART WAY.
5. TURN TENSION ADJUSTING SCREW CLOCKWISE WHILE TAPPING LIGHTLY ON CASTING WITH HANDLE OF A SCREWDRIVER.
6. WHEN AIR VALVE JUST CLOSSES, TURN TENSION ADJUSTING SCREW CLOCKWISE AN ADDITIONAL AMOUNT AS SPECIFIED ABOVE.
7. TIGHTEN LOCK SCREW AND REPLACE VACUUM BREAK DIAPHRAGM, AND ROD.

**12** CHOKE VALVE WIDE OPEN AND CAM FOLLOWER OFF STEPS OF FAST IDLE CAM

**SLOW IDLE ADJUSTMENT**

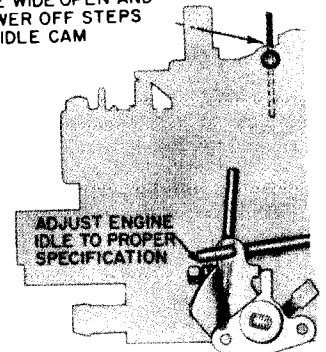

1. ENGINE AT NORMAL OPERATING TEMPERATURE, REMOVE AIR CLEANER, DISCONNECT AIR CLEANER VACUUM HOSE AT INTAKE MANIFOLD, THEN PLUG FITTING.
2. CHOKE OPEN AND AIR CONDITIONING OFF.
3. SET PARKING BRAKE AND BLOCK DRIVE WHEELS.
4. DISCONNECT CARBURETOR HOSE FROM VAPOR CANISTER (PLUG HOSE).
5. DISCONNECT DISTRIBUTOR VACUUM HOSE AT DISTRIBUTOR AND PLUG.
6. WITH DWELL AND TIMING PROPERLY ADJUSTED AND TRANSMISSION IN DRIVE ADJUST IDLE SPEED TO OBTAIN 600 R.P.M.
7. CONNECT DISTRIBUTOR VACUUM HOSE, CONNECT CARBURETOR HOSE TO VAPOR CANISTER, CONNECT AIR CLEANER HOSE AND INSTALL AIR CLEANER.

**13**

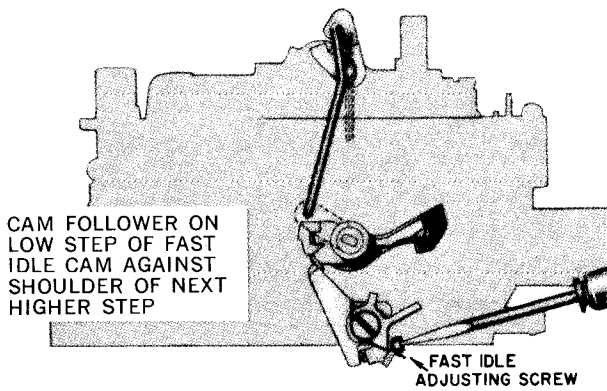

**FAST IDLE ADJUSTMENT (ON VEHICLE)**

1. ENGINE AT NORMAL OPERATING TEMPERATURE, REMOVE AIR CLEANER, DISCONNECT AIR CLEANER VACUUM HOSE AT INTAKE MANIFOLD, THEN PLUG FITTING.
2. CHOKE OPEN AND AIR CONDITIONING OFF.
3. SET PARKING BRAKE AND BLOCK DRIVE WHEELS.
4. DISCONNECT CARBURETOR HOSE FROM VAPOR CANISTER AND PLUG.
5. DISCONNECT DISTRIBUTOR VACUUM HOSE AT DISTRIBUTOR AND PLUG.
6. WITH DWELL AND TIMING PROPERLY ADJUSTED, PLACE CAM FOLLOWER ON LOW STOP AND AGAINST SHOULDER OF NEXT HIGHER STEP. ADJUST FAST IDLE SCREW TO OBTAIN 1100 RPM (TRANS. IN PARK).
7. UNPLUG DISTRIBUTOR VACUUM HOSE AND RECONNECT TO DISTRIBUTOR. UNPLUG VACUUM FITTING AT INTAKE MANIFOLD AND RECONNECT AIR CLEANER HOSE. CONNECT CARBURETOR HOSE TO CANISTER. INSTALL AIR CLEANER AND RECHECK IDLE RPM.

Figure 30-Carburetor Adjustments

# 14 IDLE MIXTURE ADJUSTMENT

## ENGINES CERTIFIED FOR 1973

(REFER TO LABEL ON R.H. VALVE COVER FOR YEAR OF CERTIFICATION)

IN CASE OF HIGH IDLE CO (OVER 1.0%) MAJOR OVERHAUL, THROTTLE BODY REPLACEMENT, OR WHEN POOR IDLE QUALITY IS APPARENT, REQUIRING REMOVAL OF THE IDLE LIMITER CAPS, THE FOLLOWING PROCEDURE MUST BE USED.

(HOWEVER)

BEFORE SUSPECTING THE CARBURETOR TO BE THE CAUSE OF POOR ENGINE PERFORMANCE OR ROUGH IDLE, CHECK IGNITION INCLUDING DISTRIBUTOR, CHECK TIMING, PLUGS AND WIRES, CHECK AIR CLEANER, EVAPORATIVE EMISSION SYSTEM, PCV SYSTEM AND COMPRESSION. ALSO, CHECK VACUUM HOSES FOR LEAK.

1. WITH ENGINE AT OPERATING TEMPERATURE, STOP ENGINE AND DISCONNECT CARBURETOR HOSE FROM VAPOR CANISTER AND PLUG HOSE.
2. REMOVE IDLE LIMITER CAPS.
3. LIGHTLY SEAT IDLE MIXTURE SCREWS, THEN BACK OUT 6 FULL TURNS
4. CONNECT CO METER TO THE EXHAUST SYSTEM.
5. WITH ENGINE RUNNING AT NORMAL CURB IDLE SET PARKING BRAKE AND BLOCK DRIVE WHEELS, AUTOMATIC TRANSMISSION IN DRIVE. ADJUST EACH IDLE MIXTURE SCREW AN EQUAL NUMBER OF TURNS TO OBTAIN A SATISFACTORY IDLE AT 600 RPM WITH A MAXIMUM CO READING OF .3%.
6. TEMPORARILY PLACE AIR CLEANER ON CARBURETOR AND RECHECK CO. READING MUST NOT BE ABOVE .3%. ADJUST IDLE MIXTURE SCREWS IF NECESSARY.
7. INSTALL NEW IDLE LIMITER CAPS (RED). INSTALL AIR CLEANER AND CARBURETOR HOSE TO CANISTER.

## ENGINES CERTIFIED FOR 1974

(REFER TO LABEL ON R.H. VALVE COVER FOR YEAR OF CERTIFICATION)

IN THE CASE OF HIGH IDLE CO (OVER .5%) MAJOR CARBURETOR OVERHAUL, THROTTLE BODY REPLACEMENT, OR WHEN POOR IDLE QUALITY EXISTS, IDLE MIXTURE MAY BE ADJUSTED. TO PROPERLY SET IDLE MIXTURE TO ACHIEVE THE SMOOTHTEST IDLE WHILE MAINTAINING EMISSION LEVELS WITHIN THE STANDARDS PRESCRIBED BY FEDERAL LAW, THE FOLLOWING PROCEDURES MUST BE FOLLOWED:

(HOWEVER)

BEFORE SUSPECTING THE CARBURETOR TO BE THE CAUSE OF POOR ENGINE PERFORMANCE OR ROUGH IDLE, CHECK IGNITION INCLUDING DISTRIBUTOR, CHECK TIMING, PLUGS AND WIRES, CHECK AIR CLEANER, EVAPORATIVE EMISSION SYSTEM, PCV SYSTEM AND COMPRESSION. ALSO, CHECK VACUUM HOSES FOR LEAK.

IF ACCURATE CO METER IS AVAILABLE.

1. WITH ENGINE AT NORMAL OPERATING TEMPERATURE. REMOVE AIR CLEANER AND DISCONNECT AIR CLEANER VACUUM HOSE AT INTAKE MANIFOLD, THEN PLUG FITTING.
2. CHOKE OPEN AIR CONDITIONING OFF.
3. SET PARKING BRAKE AND BLOCK FRONT DRIVE WHEELS.
4. DISCONNECT CARBURETOR HOSES FROM VAPOR CANISTER, DISTRIBUTOR, AND PLUG HOSES.
5. CONNECT CO METER TO EXHAUST SYSTEM TAILPIPE.
6. SET IDLE SPEED TO 600 RPM.
7. TURN EACH IDLE MIXTURE CAP IN EQUAL AMOUNTS (MAXIMUM ADJUSTMENT IS ONE HALF) UNTIL IDLE CO IS AT OR BELOW .2%. RESET IDLE SPEED, IF NECESSARY, WITH AIR CLEANER IN PLACE.
8. RECONNECT CARBURETOR TO CANISTER HOSE AND DISTRIBUTOR VACUUM ADVANCE HOSE. INSTALL AIR CLEANER AND CONNECT VACUUM HOSE.

NOTE: CO METER MUST BE CAPABLE OF LOW LEVEL, ACCURATE READINGS. METERS SHOULD BE ACCURATE WITHIN  $\pm .1\%$  CO IN THE SETTING RANGE SPECIFIED. THE METER SCALE SHOULD HAVE DIVISIONS OF .2% CO OR LESS.

IF ACCURATE CO METER IS NOT AVAILABLE.

1. WITH ENGINE AT NORMAL OPERATING TEMPERATURE. REMOVE AIR CLEANER AND DISCONNECT AIR CLEANER VACUUM HOSE AT INTAKE MANIFOLD, THEN PLUG FITTING.
2. CHOKE OPEN AIR CONDITIONING OFF.
3. SET PARKING BRAKE AND BLOCK FRONT DRIVE WHEELS.
4. DISCONNECT CARBURETOR HOSES FROM VAPOR CANISTER, DISTRIBUTOR AND PLUG HOSES.
5. SET DWELL. SET TIMING AT SPECIFIED RPM.
6. BREAK TABS OFF FROM IDLE MIXTURE SCREW CAPS.
7. CONNECT AN ACCURATE VACUUM GAUGE TO THE INTAKE MANIFOLD.
8. WITH TRANSMISSION IN DRIVE, ADJUST IDLE SPEED SCREW TO OBTAIN 600 RPM.
9. EQUALLY RICHEN (TURN OUT) MIXTURE SCREWS UNTIL MAXIMUM IDLE SPEED IS ACHIEVED. NOTE MANIFOLD VACUUM READING.
 

NOTE: IF MIXTURE SCREWS ARE APPARENTLY OUT-OF-BALANCE OR CARBURETOR IS BEING OVER-HAULED, LIGHTLY SEAT IDLE MIXTURE SCREWS, THEN BACK OUT 4 FULL TURNS. ADJUST IDLE SPEED SCREW TO OBTAIN 650 RPM.
10. EQUALLY LEAN (TURN IN) MIXTURE SCREWS UNTIL THE IDLE SPEED IS 600 RPM. MANIFOLD VACUUM READING SHOULD NOT BE REDUCED BY MORE THAN 2 INCHES OF MERCURY FROM READING OBTAINED IN STEP 9. IF READING IS REDUCED MORE THAN 2 INCHES, REPEAT PROCEDURE.
11. RECONNECT DISTRIBUTOR AND CANISTER HOSES.
12. INSTALL AIR CLEANER AND AIR CLEANER VACUUM HOSE.
13. IDLE CO SHOULD BE .2% MAXIMUM.

**15**SECONDARY CLOSING  
.020"**16**DOWNSHIFT SWITCH  
ADJUSTMENT**15**

1. CHOKE FULLY OPEN AND FAST IDLE CAM FOLLOWER OFF STEPS OF FAST IDLE CAM.
2. SLOW IDLE PROPERLY SET.
3. MAKE SURE THROTTLE LEVER TANG IS AGAINST SECONDARY THROTTLE ROD OPERATING LEVER AS SHOWN IN 3.
4. GAUGE BETWEEN ROD AND END OF SLOT AS SHOWN IN 4. SEE SPECIFICATION ABOVE.
5. TO ADJUST, OPEN THROTTLE SLIGHTLY AND BEND TANG WITH J-5197 AS SHOWN.

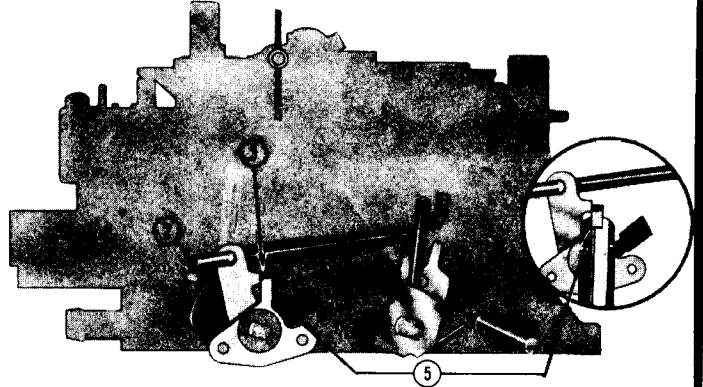
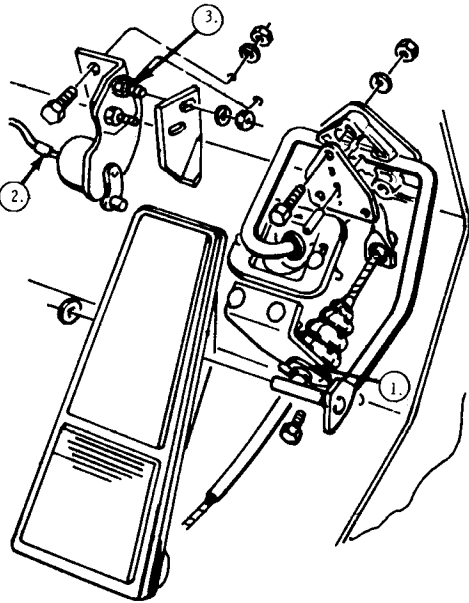
SECONDARY CLOSING ADJUSTMENT  
(ON VEHICLE)**16**

1. INSPECT TO ASSURE THAT VEHICLE HAS FULL THROTTLE TRAVEL, ADJUST TOE PANEL ACCELERATOR CABLE BRACKET IF NECESSARY.
2. CONNECT TEST LIGHT TO UPPER TERMINAL ON DOWNSHIFT SWITCH.
3. LOOSEN DOWNSHIFT SWITCH MOUNTING BOLTS.
4. FULLY DEPRESS ACCELERATOR PEDAL AND TURN IGNITION TO RUN POSITION.
5. ROTATE DOWNSHIFT SWITCH UPWARD UNTIL TEST LAMP LIGHTS—CONTINUE ROTATION 10°.
6. TIGHTEN DOWNSHIFT SWITCH MOUNTING BOLTS.

A-1895

Figure 32—Carburetor Adjustments

## ACCELERATOR LINKAGE

The accelerator control system is of the cable type. By repositioning the cable mounting bracket below the accelerator pedal some adjustment in cable length may be made to assure a full throttle position at the carburetor is obtained.

### THROTTLE CABLE ADJUSTMENT (FIGURE 33)

1. Loosen nuts "A" and "B" located on the underside of the toe panel.
2. Adjust cable until a dimension of 4-1/16" is obtained at "C".
3. Tighten nuts and torque to 7 ft. lbs.
4. Inspect carburetor during accelerator pedal operation to make certain that full throttle is obtained without overtravel.

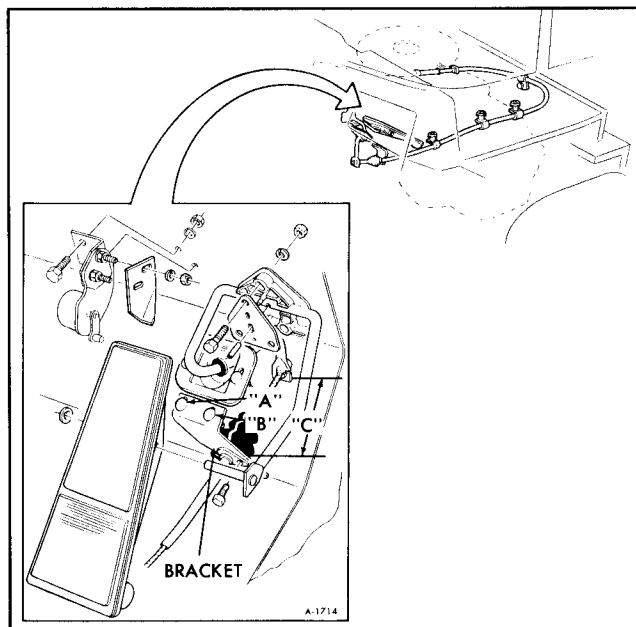

Figure 33-Accelerator Linkage

## FUEL PUMP

The fuel pump rocker arm is held in constant engagement with the eccentric on the camshaft by the rocker arm spring. As the end of the rocker arm which is in contact with the eccentric moves upward, the fuel link pulls the fuel diaphragm downward. The action of the diaphragm enlarges the fuel chamber drawing fuel from the tank through the inlet valve and into the fuel chamber. The pump delivers fuel to the carburetor only when the pressure in the outlet line is less than the pressure maintained by the diaphragm spring. Therefore, when the carburetor float needle valve opens, the spring will expand to move the diaphragm upward to force fuel past the outlet valve to the carburetor. When the carburetor float needle valve closes, the pump builds up pressure in the fuel chamber until the diaphragm spring is again compressed. The diaphragm will then remain stationary until more fuel is required by the carburetor.

### INSPECTION AND TEST

There are three tests that can be preformed to evaluate the fuel pump without removing the pump from the engine. It is important that the pump performs properly using all three tests.

1. Be sure there is gasoline in the tank.

2. Check for loose line connections. A leak at the pressure side of the system (line from pump to carburetor) will be indicated by dripping fuel. A leak in the suction side of the system (line from gas tank to pump) will not be apparent except in its effect of reducing volume of fuel on the pressure side of the system.

3. Look for bends or kinks in lines or hoses which will reduce flow. Check the fuel pump inlet hose routing to be sure it is not bent or kinked.

#### Fuel Flow Test

- a. Remove coil secondary wire from distributor and ground to block so that engine can be cranked without starting.

- b. Disconnect fuel line at the carburetor inlet fitting. Install a rubber hose approximately 8-10" long over the end of the fuel line.

- c. Place suitable container at end of the hose and crank engine a few revolutions.

**NOTE:** If little or no gasoline flows from open end of line, then the fuel line is restricted, gas

tank filter restricted or the pump is inoperative. Before removing pump, disconnect fuel lines at fuel pump and at gas tank and blow through them with an air hose to make sure they are clear. Reconnect fuel lines to pump and gas tank.

d. Reconnect fuel line at the carburetor, tighten line fitting while holding carburetor fuel inlet nut. Start engine and check for leaks.

#### Pump (Inlet) Vacuum

Low vacuum or complete loss of vacuum provides insufficient fuel to the carburetor to operate the engine throughout normal speed range.

a. Disconnect hose from fuel tank to fuel pump at the fuel pump. Fasten hose in an up position so that fuel will not run out.

b. Connect one end of a short hose to the fuel pump inlet and attach a vacuum gauge to the other end. Start engine, gauge should register not less than 15 in. vacuum. If less than 15 in. of vacuum, replace pump.

#### Pump (Outlet) Pressure

Even if fuel flows in good volume from line at carburetor, it is advisable to make certain that pump is operating within limits.

a. Disconnect fuel line at the carburetor inlet fitting. Install a rubber hose approximately 8/10" long over the line and attach a low reading pressure gauge. Hold the gauge up so that it is approximately 16" above the fuel pump.

b. Start engine and run at slow idle (using gasoline in carburetor bowl) and note reading on pressure gauge.

c. If pump is operating properly, the pressure should be 5-1/2 to 6-1/2 constant. If pressure is too high or too low or varies materially at different engine speeds, the pump should be replaced.

## FUEL PUMP REPLACEMENT

### Removal

1. Raise Motor Home.
2. Disconnect fuel line to carburetor and fuel hose from fuel tank.
3. Loosen nut securing top of fuel pump to block.
4. Remove bolt securing bottom of fuel pump to block.
5. Remove pump.

### Installation

1. Install fuel pump with new gasket.
2. Install bolt and tighten alternately with nut to assure an even draw down of pump to block.
3. Connect fuel hose and line to fuel pump. Tighten fuel fittings to carburetor and fuel pump. Hold nut at carburetor inlet while applying torque.
4. Lower Motor Home.

## AIR CLEANER

### REMOVAL

1. Remove engine cover.
2. Remove wing nut on top of air cleaner.
3. Disconnect P.C.V. pipe from the air cleaner housing. See Figure 34.
4. Lift air cleaner housing off carburetor high enough to reach underneath it and disconnect the vacuum hose from the intake manifold. See Figure 34.
5. Remove air cleaner housing.
6. Inspect air cleaner housing gasket on carburetor, replace gasket as needed.

NOTE: : To install new gasket:

1. Completely remove old gasket.
2. Remove protective paper from adhesive side of new gasket.
3. Install new gasket adhesive side down, on carburetor air horn.

### INSTALLATION

1. While installation the air cleaner housing connect the vacuum hose to the intake manifold.

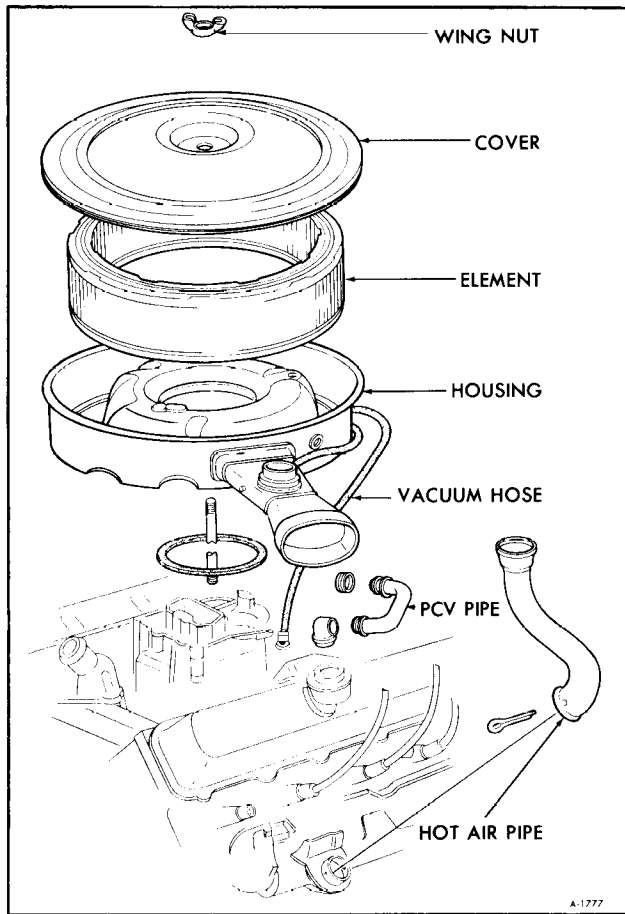

Figure 34-Air Cleaner

2. Position hot air pipe so it enters the air cleaner properly.

3. Connect P.C.V. pipe to the air cleaner housing.

4. Install wing nut and tighten.

5. Install engine cover.

### AIR CLEANER ELEMENT

The air cleaner element should be replaced regularly according to the maintenance information in Section 0 of this manual.

The element is accessible by removing the wing nut and the air cleaner cover.

# SECTION 6T

## EMISSION CONTROL SYSTEMS

Contents of this section are listed below:

SUBJECT	PAGE NO.
Positive Crankcase Ventilation (P.C.V.)	
Description .....	6T-2
P.C.V. System Testing .....	6T-2
Instruction For Testing P.C.V. Valve.....	6T-2
Instruction For Testing Complete System .....	6T-2
Controlled Combustion System (C.C.S.)	
Description .....	6T-3
Purpose.....	6T-3
Operation .....	6T-3
Diagnosis .....	6T-4
Vacuum Motor Replacement .....	6T-5
Sensor Replacement.....	6T-6
Exhaust Manifold Shroud .....	6T-6
Evaporation Control System (E.C.S.)	
Thermal Vacuum Switch (T.V.S.)	
Description .....	6T-6
Operation .....	6T-6
Vacuum Hose Routing .....	6T-7
Functional Check.....	6T-7

## POSITIVE CRANKCASE VENTILATION (P.C.V.)

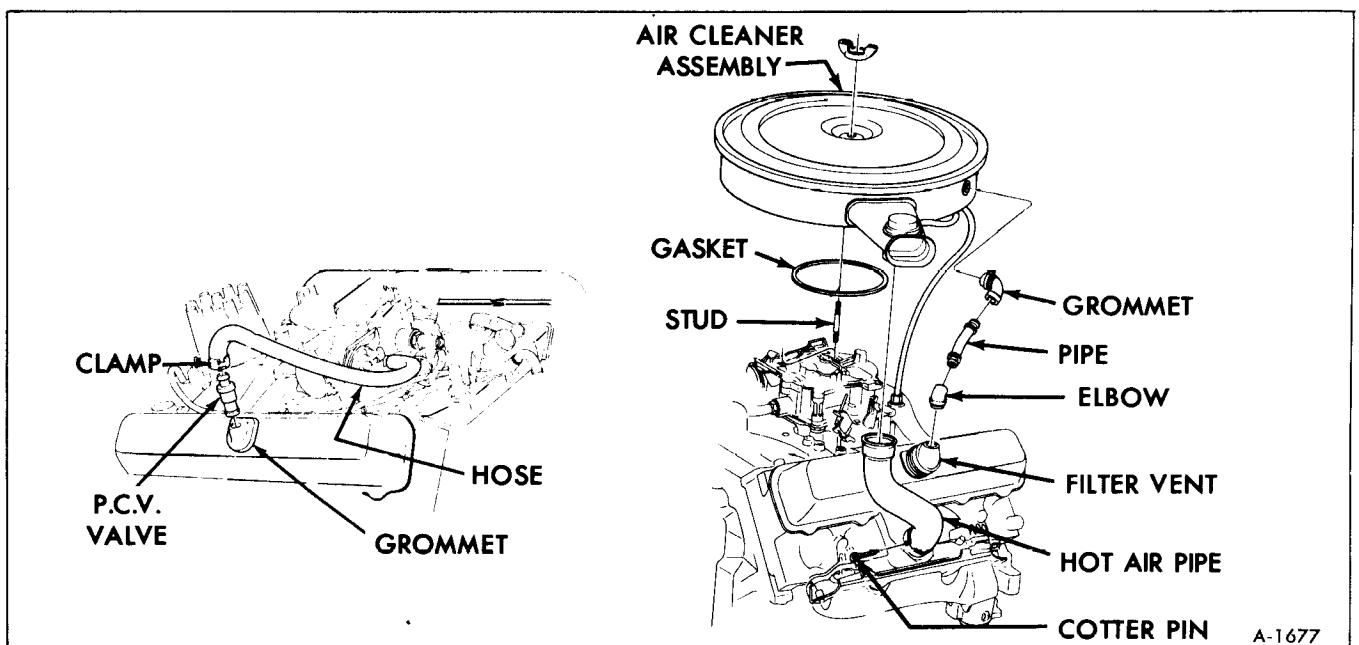

Figure 1-Positive Crankcase Ventilation System



## DESCRIPTION (FIGURE 1)

At idle or normal road speeds, intake manifold vacuum causes fresh air to be drawn through the engine air filter, then to the left valve cover where it joins with the crankcase vapors. This mixture is then drawn through the P.C.V. valve to the base of the carburetor where the vapors are mixed with normal fuel air mixture and burned.

When the engine is running either at idle or the vehicle is traveling at normal speeds, intake manifold vacuum is sufficient to draw crankcase vapors caused by engine blow-by through the spring loaded P.C.V. valve.

At high road speeds or heavy acceleration, the engine blow-by is increased and at the same time, intake manifold vacuum decreased. When this occurs, there is a reverse action, crankcase vapors released through the crankcase filter are returned back into the intake manifold through the carburetor. When operating the engine under zero vacuum or a manifold pressure condition such as a backfire or during engine cranking, the check valve is closed by spring tension to prevent fuel vapor from entering the crankcase. The valve is also closed under wide-open throttle condition but since this is for a very short duration of time, no irregularity will exist.

## P.C.V. SYSTEM TESTING

The CT-3 tester is an extremely sensitive vacuum-pressure gauge designed to accurately indicate the small amount of vacuum or pressure in the system. The tester is also used to test the P.C.V. valve after it has been removed.

### INSTRUCTIONS FOR TESTING P.C.V. VALVE

1. Disconnect P.C.V. valve from crankcase – leave valve connected to hose.

2. Adjust tester selector knob to “E”.
3. Connect hose to tester body and vent valve adapter CT-18.
4. With engine at operating temperature, at idle and transmission in “PARK,” hold the vent valve adapter CT-18 against the crankcase end of the vent valve.
5. Hold the tester upright and look directly into the test window and observe the color. Be sure the adapter is firmly sealed against the valve, there are no leaks and hose is not kinked.
6. An all “GREEN” window reading indicates valve is OK. Any “YELLOW” showing indicates the valve needs replacing.

### INSTRUCTIONS FOR TESTING COMPLETE SYSTEM

1. Remove oil dipstick and plug hole with dipstick hole plug CT-12 (part of CT-3 tester).
2. Remove tube from elbow at air cleaner and plug tube with CT-11.
3. Adjust tester selector knob to “K”.
4. Connect hose to tester body and tester adapter CT-14
5. Remove oil filler cap and place tester adapter CT-14 into opening.
6. With engine at operating temperature, running at idle and transmission in “PARK,” hold tester upright and look directly into tester window and note the color, it should be green. If not, be sure there are no leaks and hose is not kinked. Refer to P.C.V. Diagnosis Chart for other items to look for.

## P.C.V. DIAGNOSIS CHART (USING CT-3 TESTER)

WINDOW READING	PROBABLE CAUSE	CORRECTION
GREEN	System Satisfactory. Vent valve partially plugged. Blow-by close to capacity of valve.	Check Valve.

## P.C.V. DIAGNOSIS CHART (USING CT-3 TESTER)

WINDOW READING	PROBABLE CAUSE	CORRECTION
YELLOW	Tester hose kinked or blocked. Crankcase not sealed properly. Tester "selector knob" set incorrectly. Vent-valve partially plugged. Slight kink in CT-3 tester hose.	Reposition or clean hose.  Check tester plugs and other seal-off points. Check setting.  Check vent valve.  Reposition tester hose.
YELLOW-GREEN	Slight engine blow-by. Crankcase not sealed properly. Tester "selector knob" set incorrectly. Vent-valve partially or fully plugged.	Check vent valve. Check tester plugs and other seal-off points. Check setting.  Check vent valve.
RED-YELLOW	Engine blow-by exceeds valve capacity. Rubber vent hose collapsed or plugged.	Engine overhaul indicated.  Clean or replace hose.
RED	Vent-valve plugged. Vent-valve stuck at engine off position. Rubber vent hose collapsed or plugged. Extreme engine blow-by.	Check vent valve. Check vent valve.  Replace hose.  Engine requires major overhaul.

## CONTROLLED COMBUSTION SYSTEM (C.C.S.)

A Controlled Combustion System is standard equipment on the engine. The Controlled Combustion System consists of an air cleaner assembly which includes a temperature sensor, vacuum motor, control damper assembly and connecting vacuum hoses. The motor is controlled by the temperature sensor. The vacuum motor operates the air control damper assembly to control the flow of pre-heated and non pre-heated air. The pre-heated air is obtained from the hot air pipe and shroud on the exhaust manifold.

### PURPOSE

At underhood temperatures below 79 degrees F. the Control Combustion System directs heated air

into the air cleaner. This system provides the most desirable emission control throughout the operating range of the engine and results in improved fuel economy, improved engine warm-up and eliminates tendency for ice to form in the carburetor.

### OPERATION (FIGURES 2, 3 & 4)

During engine warm-up with engine compartment temperature at 79 degrees F. the temperature sensor is closed. This allows engine vacuum to be directed to the vacuum motor closing the damper assembly to outside air. With the damper closed, the cool air will flow through the openings at the ends of the shroud where it is heated. The heated air then

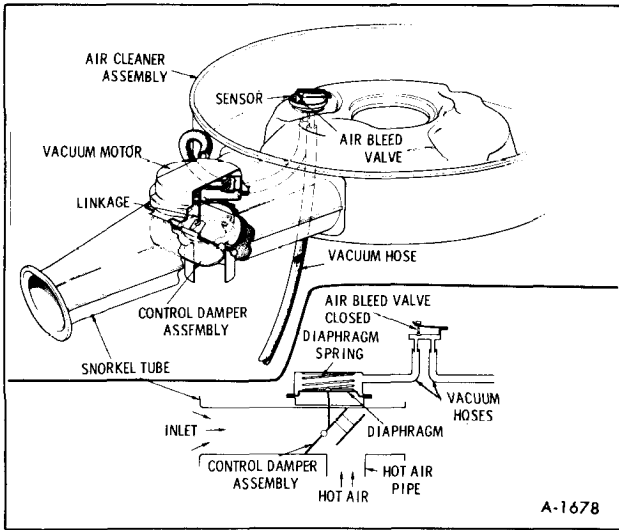

Figure 2—Hot Air Delivery Mode

flows up through the hot air pipe and adapter into the air cleaner. As the temperature inside the air cleaner reaches approximately 123 degrees F, the sensor bleeds off vacuum to the vacuum motor causing the control damper to open allowing underhood air to be mixed with the heated air as needed to keep the air temperature approximately 123 degrees F. If the ambient temperature is 123°F or below.

Under full throttle or below 3 in. Hg. to 7 in. Hg., the vacuum motor will no longer hold the valve open to hot air. The hot air pipe is closed off allowing only outside air to enter the air cleaner.

## DIAGNOSIS

### VACUUM MOTOR AND DAMPER ASSEMBLY

1. With the engine off, remove air cleaner cover

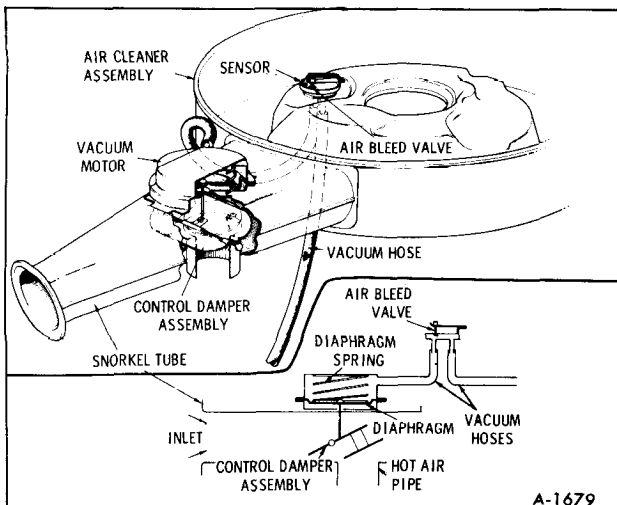

Figure 3—Regulating Mode

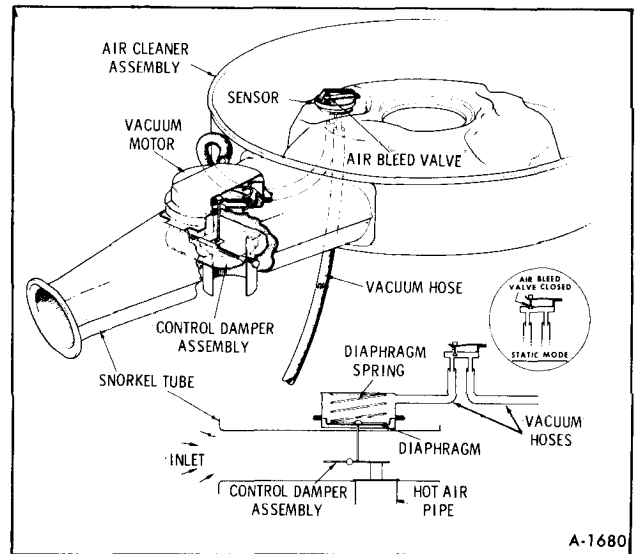

Figure 4—Cold Air Delivery Mode

and tape thermometer J-5421 in air cleaner next to sensor (See figure 5).

**NOTE:** If temperature is below 79 degrees F, continue to Step 2. If temperature is above 79 degrees F remove air cleaner and allow to cool to at least 72 degrees F.

2. Install a tee in vacuum line at vacuum motor and connect a vacuum gauge in line.

3. With the engine off, the control damper should be open.

4. Install the cover on air cleaner without the wing nut and start the engine.

5. With engine at idle speed, the control damper should be closed with the ambient temperature at or below 79 degrees F.

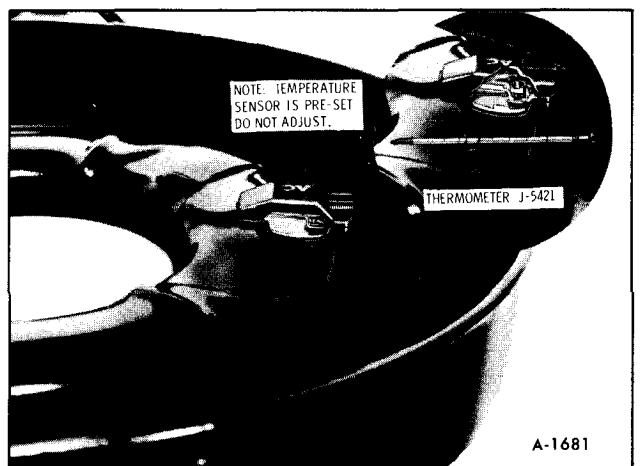

Figure 5—Checking Sensor

6. Using a small mirror observe the control damper snorkel; when it reaches the full open position (outside air), quickly remove cover on air cleaner and record reading on thermometer and vacuum gauge.

## SPECIFICATIONS FOR DAMPER OPERATION

### Temperature:

- 79 degrees F. or lower, damper fully closed.
- 123 degrees F. or higher, damper fully open.

### Vacuum:

- 3 in. hg. of vacuum or lower, damper fully open below 79 degrees F.
- 7 in. hg. of vacuum or higher, damper fully closed below 79 degrees F.

1. If temperature is within specifications, Controlled Combustion System is functioning properly.

2. If temperature is out of specifications and vacuum is correct, replace sensor.

3. If both temperature and vacuum are within specifications and damper is not operating correctly, replace vacuum motor.

4. If both temperature and vacuum are not within specifications it is an indication that the vacuum motor diaphragm is leaking.

## VACUUM MOTOR REPLACEMENT REMOVAL

1. Remove air cleaner.
2. Disconnect vacuum hose from motor.
3. Drill out the two spot welds initially with a 1/16" drill, then enlarge as required to remove the retaining strap. Do not damage the snorkel tube (See figure 6.).
4. Remove motor retaining strap.
5. Lift up motor, cocking it to one side to unhook the motor linkage at the control damper assembly.

## INSTALLATION

1. Drill a 7/64" hole in snorkel tube at point "A" as shown in Figure 6.
2. Insert vacuum motor linkage into control damper assembly.

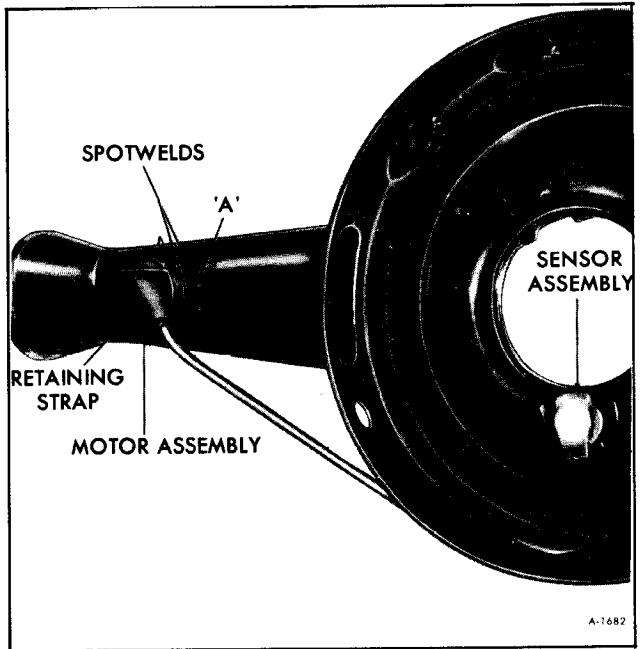

Figure 6—Air Cleaner Spot Welds

3. Use the motor retaining strap and sheet metal screw provided in the motor service package to secure the retaining strap and motor to the snorkel tube.

4. Make sure the screw does not interfere with the operation of the damper assembly. Shorten screw if required.

5. Connect vacuum hose to motor and install air cleaner.

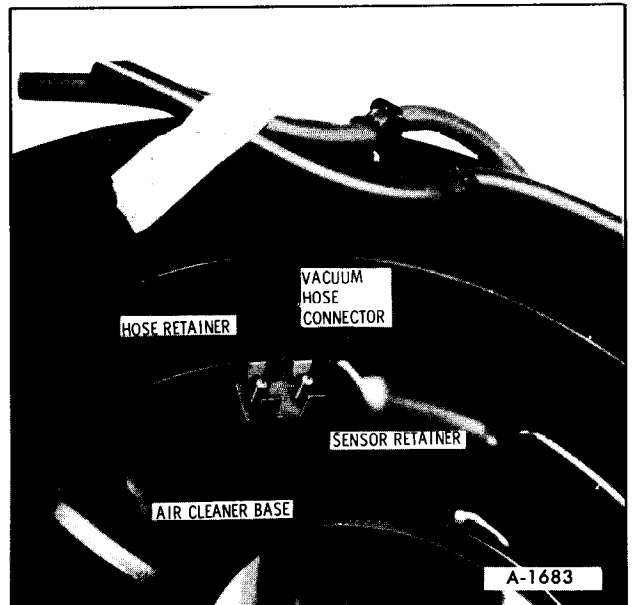

Figure 7—Sensor Retainer

## SENSOR REPLACEMENT

### REMOVAL

1. Remove air cleaner.
2. Detach hoses at sensor.
3. Pry up tabs on sensor retaining clip and remove clip and sensor from air cleaner. Note position of sensor for installation (See figure 7).

### INSTALLATION

1. Install sensor and gasket assembly in original position.
2. Press retainer clip on hose connectors.
3. Connect vacuum hoses and install air cleaner on engine.

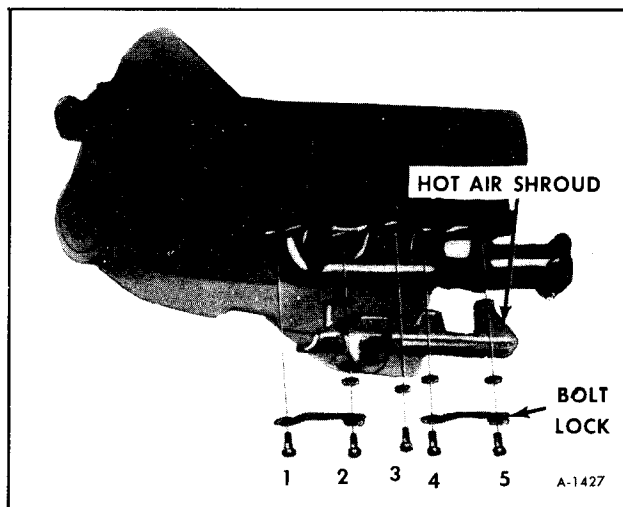

Figure 8—Hot Air Shroud

## EXHAUST MANIFOLD SHROUD

Exhaust manifold hot air shroud is shown in Figure 8. Refer to Section 6A for replacement procedures.

## EVAPORATION CONTROL SYSTEM

This system is designed to reduce fuel vapor emissions that normally vent to atmosphere from the gasoline tank and carburetor fuel bowl. The air cleaner filter mounted at the bottom of the canister

requires replacement at intervals specified in Section 0. All other parts are serviced as outlined in Section 8 of this manual.

## THERMAL VACUUM SWITCH (T.V.S.)

### DESCRIPTION

The retarded spark setting at idle speeds required for effective emission control makes engines tend to run hotter during idle or low speed conditions.

To protect against overheating, the engine is equipped with a thermostatic vacuum switch (T.V.S.). The temperature-sensitive switch and valve assembly is mounted in the engine cooling jacket near the right front of the engine, see Figure 9, and connected into the vacuum advance system.

pressure and directs manifold vacuum to the advance mechanism. This advances the spark timing slightly and speeds up the engine. The result is less heat rejected to the coolant together with higher fan

### OPERATION

When the engine coolant reaches a specified high temperature (216°F.), the valve opens against spring

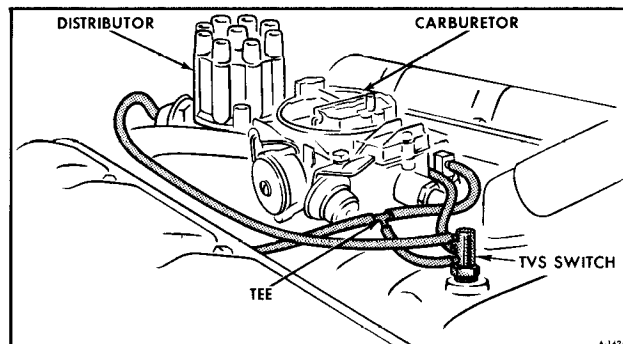

Figure 9—T.V.S. Location

speeds for better cooling action. When the engine has cooled down, the TVS switch moves the valve back to retard spark timing.

### VACUUM HOSE ROUTING TO T.V.S. SWITCH (FIGURE 9)

Port "D"	Vacuum hose to the distributor vacuum advance.
Port "C"	Vacuum hose to the carburetor port.
Port "MT"	Vacuum hose to intake manifold elbow.

### FUNCTIONAL CHECK

To test the switch function, disconnect the distributor vacuum hose at port "D" of the T.V.S. switch, see Figure 10, connect a vacuum gauge and check for vacuum with the engine idling at normal operating temperature. If more than 5 in. Hg. of vacuum is present and the hoses are connected to the proper ports, check further with instruments designed to test the switch such as BT-7002.

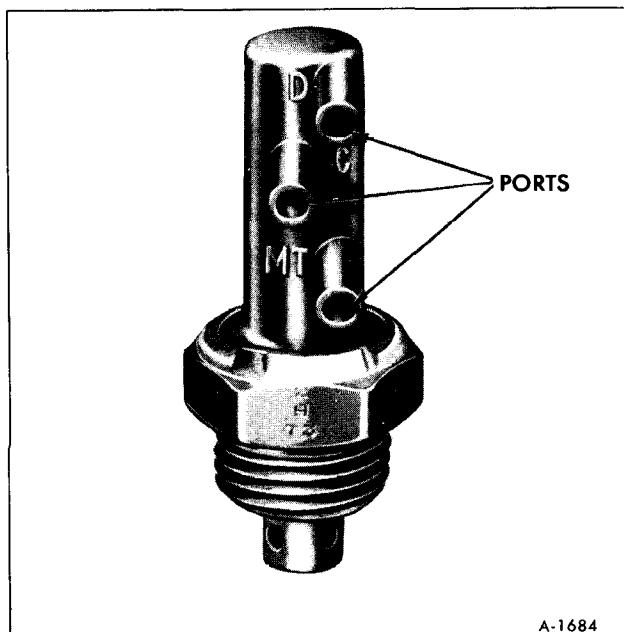

Figure 10—Thermostatic Vacuum Switch

The switch must be installed with a soft setting sealant on the threads.



# SECTION 6Y

## ENGINE ELECTRICAL

Contents of this section are listed below:

SUBJECT	PAGE NO.
Batteries .....	6Y-1
Battery Specifications .....	6Y-13
Generating System.....	6Y-13
Generator Specifications .....	6Y-25
Ignition System .....	6Y-25
Ignition System Specifications.....	6Y-42
Starting System .....	6Y-42
Starter Specifications .....	6Y-50

## BATTERIES

**CAUTION:** *Never expose battery to open flame or electric spark—battery action generates hydrogen gas which is flammable and explosive. Don't allow battery fluid to contact skin, eyes, fabrics, or painted surfaces—fluid is a sulfuric acid solution which could cause serious personal injury or property damage. Wear eye protection when working with battery.*

*Remove rings, metal watchbands and other metal jewelry before jump starting or working around a battery, and be careful in using metal tools—if such metal should contact the positive battery terminal (or metal in contact with it) and any other metal on the vehicle a short circuit may occur which could cause personal injury.*

The Motor Home will have two batteries mounted behind the right front access door and a third near the motor generator if the vehicle is so equipped.

The GMC Dual Battery System provides power from two batteries to the Motor Home 12-volt electrical system either in combination or singularly. The components used to provide charging and/or switching are conventional, except for a diode assembly with which both batteries will receive charging current whenever the vehicle is running. The diode assembly has separate outputs to the two batteries and provides isolation between the batteries and their associated circuits whenever the engine is not running. The main battery (or automotive battery) supplies power to the chassis circuit; i.e., engine, external lights, etc. The auxiliary battery (living area battery) powers the Motor Home living area, i.e., internal lights, refrigerator, etc.

and the service information in this section will pertain to all of them.

**NOTE:** Current production batteries are not equipped with the "Delco Eye" level indicator as shown in Figure 1. In addition the vent plugs are now equipped with a sintered carbide insert which acts as a flame arrestor.

The energizer (figure 1) is made up of a number of separate elements, each located in an individual cell in a hard rubber case. Each element consists of an assembly of positive plates and negative plates containing dissimilar active materials and kept apart by separators. The elements are immersed in an electrolyte composed of dilute sulfuric acid. Plate straps located on the top of each element connect all the positive plates and all the negative plates into groups.

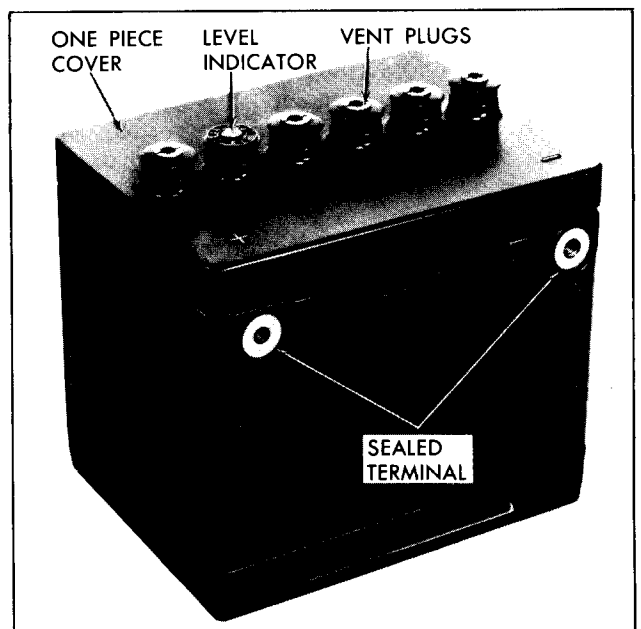

Figure 1—Energizer

In all cases the batteries are all Delco Energizers

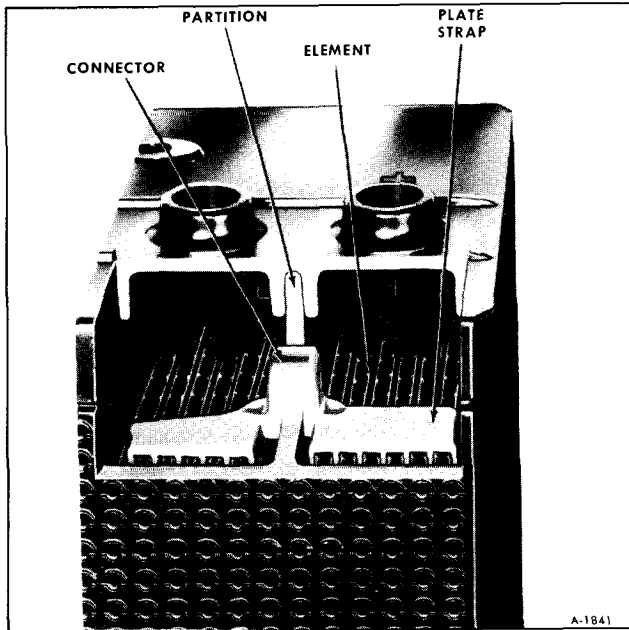

Figure 2—Internal View of Energizer

The elements are connected in series electrically by connectors that pass directly through the case partitions between cells. The energizer top is a one piece cover. The cell connectors, by passing through the cell partitions, connect the elements along the shortest practical path (figure 2). With the length of the electrical circuit inside the Energizer reduced to a minimum, the internal voltage drop is decreased resulting in improved performance, particularly during engine cranking at low temperatures.

The terminals of this type Energizer, passing through the side of the case, are positioned out of the "wet" area surrounding the vent wells. Normal spillage, spewing, condensation and road splash are not as likely to reach or remain on the vertical sides where the terminals are located. This greatly decreases the cause of terminal corrosion. Also, construction of the terminals is such that the mating cable connector seals the junction and provides a permanently tight and clean connection. Power robbing resistance in the form of corrosion is thereby eliminated at these maintenance-free connections.

The hard, smooth, one piece cover greatly reduces the tendency for corrosion to form on the top of the Energizer. The cover is bonded to the case forming an air-tight seal between the cover and case.

Electrical energy is released by chemical reactions between the active materials in the two dissimilar plates and the electrolyte whenever the Energizer is being "discharged." Maximum electrical energy is released only when the cells are being discharged from a state of full charge.

As the cells discharge, chemical changes in the active materials in the plates gradually reduce the potential electrical energy available. "Recharging" the Energizer with a flow of direct current opposite to that during discharge reverses the chemical changes within the cells and restores them to their active condition and a state of full charge.

There are two types of Energizers, the "dry charge" type and the "wet charge" type. The difference in types depends on the method of manufacture. A "dry charge" Energizer contains fully charged elements which have been thoroughly washed and dried. This type of Energizer contains no electrolyte until it is activated for service in the field and, therefore, leaves the factory in a dry state. Consequently, it is called a "dry charge" Energizer.

Each vent well in a "dry charge" Energizer has a hard rubber seal to prevent the entrance of air and moisture which would oxidize the negative active materials and reduce the freshness of the Energizer (figure 3). The hard rubber seals and the bonding between the case and one-piece cell cover make possible a vacuum sealed assembly which can be stored for very long periods of time without detrimental effects.

Before activating the "dry charge" Energizer, the hard rubber seals are broken simply by pushing the special vent plug down into each vent well. The seals drop into the cells, and can remain there since they are not chemically active and will cause no harm.

A wet charged Energizer contains fully charged elements which are filled with electrolyte before being shipped from the factory.

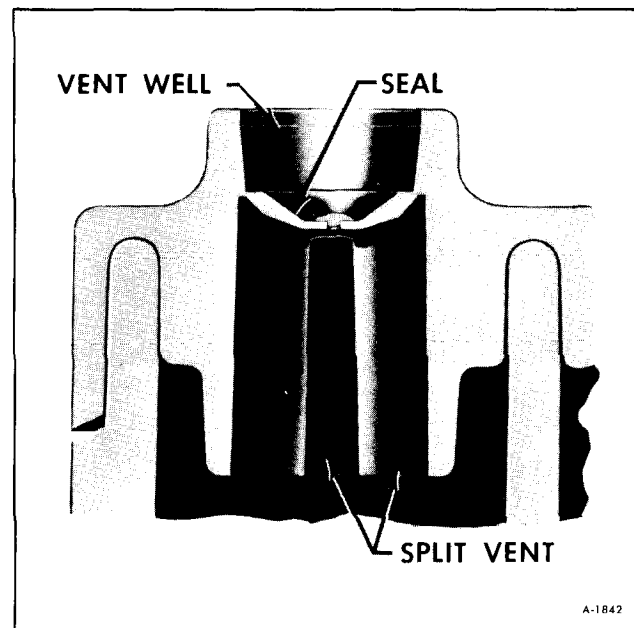

Figure 3—Vent Well Construction



## THEORY OF OPERATION

The lead-acid Energizer or storage battery (figure 1) is an electrochemical device for converting chemical energy into electrical energy. It is not a storage tank for electricity as is often believed, but instead, stores electrical energy in chemical form.

Active materials within the battery react chemically to produce a flow of direct current whenever lights, radio, cranking motor, or other current consuming devices are connected to the battery terminal posts. This current is produced by chemical reaction between the active materials of the PLATES and sulfuric acid of the ELECTROLYTE.

The battery performs three functions in automotive applications:

1. It supplies electrical energy for the cranking motor and for the ignition system as the engine is started.
2. It supplies current for the lights, radio, heater, and other accessories when the electrical demands of these devices exceed the output of the generator.
3. The battery acts as a voltage stabilizer in the electrical system. Satisfactory operation of the vehicle is impossible unless the battery performs each of these functions.

The simplest unit of a lead-acid storage battery is made up of two unlike materials, a positive plate and a negative plate, kept apart by a porous separator. This assembly is called an "ELEMENT" (figure 4).

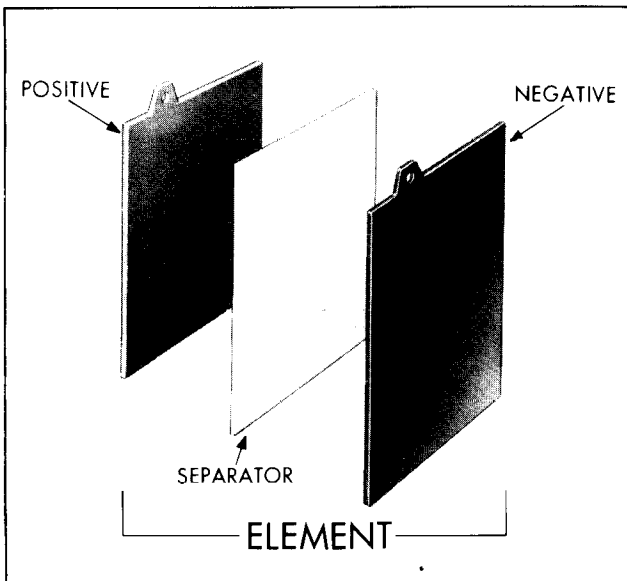

Figure 4—Battery Element

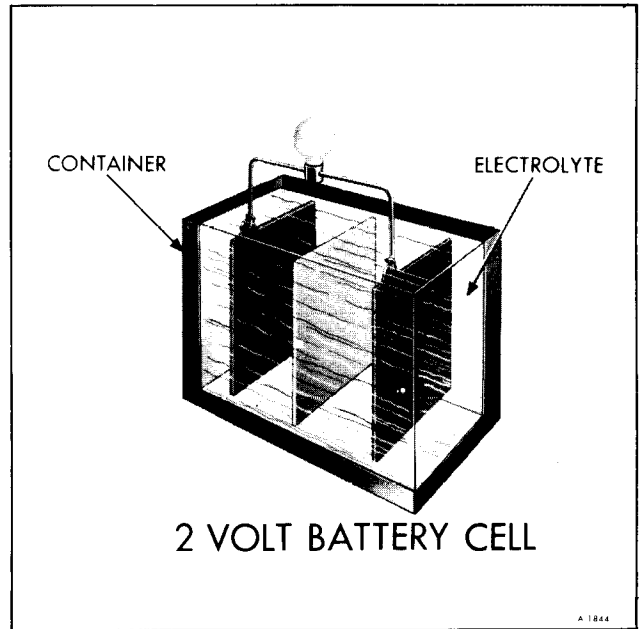

Figure 5—Two Volt Battery Cell

When this simple element is put in a container filled with a sulphuric acid and water solution called "electrolyte", a two-volt "cell" is formed. Electricity will flow when the plates are connected to an electrical load (figure 5).

An element made by grouping several positive plates together and several negative plates together with separators between them also generates two-volts but can produce more total electrical energy than a simple cell (figure 6).

When six cells are connected in series, a "battery" of cells is formed which produces six times as much electrical pressure as a simple cell, or a total of 12 volts (figure 7).

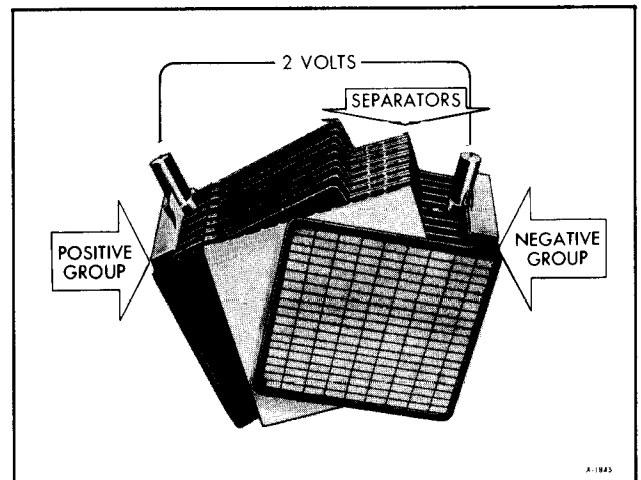

Figure 6—Battery Element (Compound)

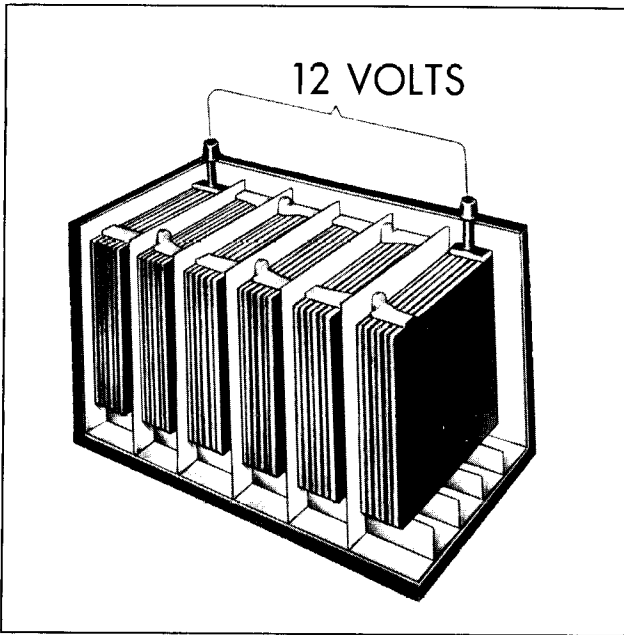

Figure 7—Typical 12-Volt Battery Cell Arrangement

If the battery continuously supplies current, it becomes run-down or discharged. This is where the generator gets into the act. The generator restores the chemical energy to the battery. This is done by sending current through the battery in a direction opposite to that during discharge. The generator current reverses the chemical actions in the battery and restores it to a charged condition,

## ENERGIZER RATING

Each battery generally has two classifications of ratings: (1) a 20 hour rating at 80° F and, (2) a cold rating at 0° F which indicates the cranking load capacity. The Ampere/Hour rating found on batteries was based on the 20 hour rating. That is, a battery capable of furnishing three (3) amperes for 20 hours while maintaining a specified average individual cell voltage would be classified as a 60 ampere hour battery (e.g. 3 amperes x 20 hours = 60 A.H.) a PWR (Peak Watt Rating) has been developed as a measure of the Energizer's cold cranking ability. The numerical rating is embossed on each case at the base of the Energizer. This value is determined by multiplying the max. current by the max. voltage. The PWR should not be confused with the ampere hour rating since two batteries with the same ampere hour rating can have quite different watt ratings. For battery replacement, a unit of at least equal power rating must be selected.

## BATTERY DIAGNOSIS

### TESTING PROCEDURES

Testing procedures are used to determine

whether the battery is (1) good and usable, (2) requires recharging or (3) should be replaced. Analysis of battery conditions can be accomplished by performing a visual inspection, instrument test and the full charge hydrometer test. Refer to test procedure chart in this section.

### Visual Inspection

The first step in testing the battery should be a visual inspection, which very often will save time and expense in determining battery condition.

- Check the outside of the battery for a broken or cracked case or a broken or cracked cover. If any damage is evident, the battery should be replaced.

- Note the electrolyte level. Levels that are too low or too high may cause poor performance, as covered in the section entitled "General Information".

- Check for loose cable connections. Correct as required before proceeding with tests.

### Instrument Test

A number of suppliers have approved testing equipment available. These testers have a programmed test procedure consisting of a series of timed discharge and charge events, requiring approximately 2 to 3 minutes, that will determine the condition of the battery with a high degree of accuracy. When using these testers, the procedure recommended by the tester manufacturer should be followed. Batteries should not be charged prior to testing as doing so may alter the test results. If a tester is not available for testing, the "Specific Gravity Cell Comparison Test" may be used or an alternate method, but with a sacrifice in testing accuracy.

**NOTE:** New energizers which have become completely discharged over a relatively long period of time, such as during vehicle storage, should be tested by the hydrometer method. Energizers discharged to this degree cannot be accurately tested using equipment requiring load capability comparison tests.

### Full Charge Hydrometer Test

This test should be used only on Energizers which test good with testing equipment or "Specific Gravity Cell Comparison Test" but which subsequently fail in service.

## BATTERY TEST PROCEDURE

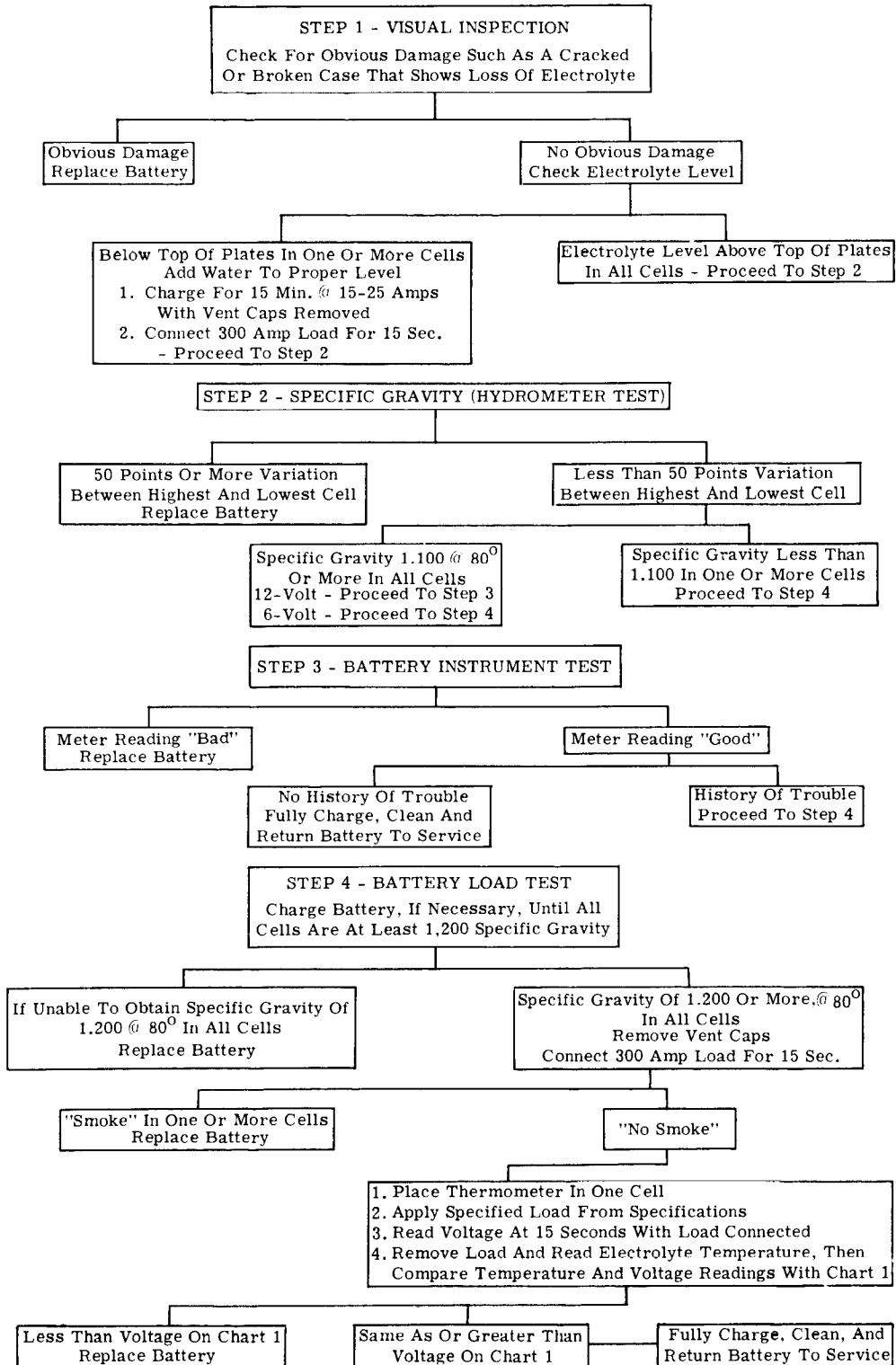

NOTE: Chart No. 1 is in Specifications

T-8031

- Remove the Energizer from the vehicle, and adjust the electrolyte level as necessary, by adding colorless, odorless, drinking water.

- Fully charge the Energizer at the Slow Charging rate as covered in the section entitled "Charging Procedures".

- Measure the specific gravity of the electrolyte in each cell and interpret as follows:

**Hydrometer Reading Less Than 1.230**—Full charge hydrometer readings less than 1.230 corrected for temperature indicate the Battery is defective and should be replaced.

**Hydrometer Readings Above 1.310**—Full charge hydrometer readings above 1.310 corrected for temperature indicate that the cells have been improperly filled (activation) or improperly serviced. Poor service and short Battery life will result.

**Load Test**

In addition to the instrument test and full charge hydrometer test, the following load test may also be performed to check the condition of the battery.

**NOTE:** Equipment to perform this test may be procured from local suppliers of testing equipment.

To begin, charge the battery, if necessary, until all cells are at least 1.200 specific gravity.

1. If unable to obtain specific gravity 1.200 @ 80°F, in all cells, replace battery.

2. If able to obtain a specific gravity of 1.200 or more @ 80°F. in all cells, remove the vent caps and connect a 300 amp. load for 15 seconds.

- a. If smoke occurs in one or more cells, replace the battery.

- b. If smoke does not occur proceed to step 3.

3. Place a thermometer in one cell and apply a specified load from specifications. Read the voltage at 15 seconds with load connected, then remove load and read electrolyte temperature. Compare temperature and voltage readings with chart No. 2.

- a. If reading is less than voltage on chart No. 1, replace battery.

- b. If reading is same as or greater than voltage on chart No. 1, fully charge, clean and return battery to service.

**Specific Gravity Readings (Figure 8)**

A hydrometer can be used to measure the specific gravity of the electrolyte in each cell.

The hydrometer measures the percentage of sulphuric acid in the battery electrolyte in terms of specific gravity. As a battery drops from a charged to a discharged condition, the acid leaves the solution and enters the plates, causing a decrease in specific gravity of electrolyte. An indication of the concentration of the electrolyte is obtained with a hydrometer.

When using a hydrometer, observe the following points:

1. Hydrometer must be clean, inside and out, to insure an accurate reading.

2. Hydrometer readings must never be taken immediately after water has been added. The water must be thoroughly mixed with the electrolyte by charging for at least 15 minutes at a rate high enough to cause vigorous gassing.

3. If hydrometer has built-in thermometer, draw liquid into it several times to insure correct temperature before taking reading.

4. Hold hydrometer vertically and draw in just enough liquid from battery cell so that float is free floating. Hold hydrometer at eye level so that float is vertical and free of outer tube, then take reading at surface of liquid. Disregard the curvature where the liquid rises against float stem due to surface tension.

5. Avoid dropping battery fluid on vehicle or clothing as it is extremely corrosive. Any fluid that

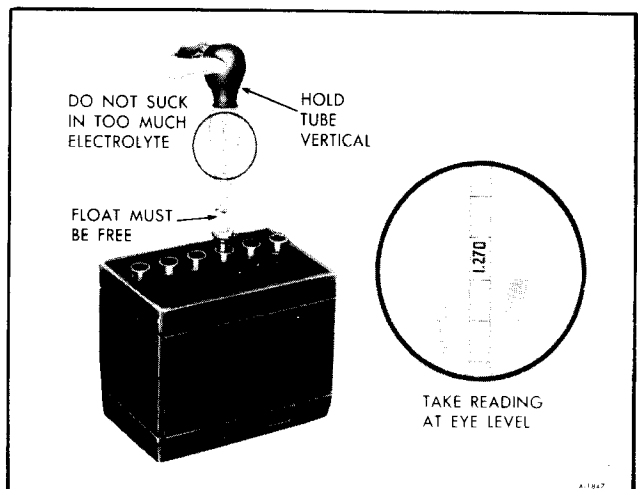

Figure 8—Checking Specific Gravity

drops should be washed off immediately with baking soda solution.

The specific gravity of the electrolyte varies not only with the percentage of acid in the liquid but also with temperature. As temperature increases, the electrolyte expands so that the specific gravity is reduced. As temperature drops, the electrolyte contracts so that the specific gravity increases. Unless these variations in specific gravity are taken into account, the specific gravity obtained by the hydrometer may not give a true indication of the concentration of acid in the electrolyte.

A fully charged Battery will have a specific gravity reading of approximately 1.270 at an electrolyte temperature of 80°F. If the electrolyte temperature is above or below 80°F, additions or subtractions must be made in order to obtain a hydrometer reading corrected to the 80°F standard. For every 10° above 80°F, add four specific gravity points (.004) to the hydrometer reading. Example: A hydrometer reading of 1.260 at 110°F would be 1.272 corrected to 80°F, indicating a fully charged Battery. For every 10° below 80°F, subtract four points (.004) from the reading. Example: A hydrometer reading of 1.272 at 0°F would be 1.240 corrected to 80°F, indicating a partially charged Battery.

### Specific Gravity Cell Comparison Test

This test may be used when an instrument tester is not available. To perform this test measure the specific gravity of each cell, regardless of state of charge, and interpret the results as follows:

- If specific gravity readings show a difference between the highest and lowest cell of .050 (50 points) or more, the Battery is defective and should be replaced.

Since the Energizer is a perishable item which requires periodic servicing, a good maintenance program will insure the longest possible Battery life. If the Energizer tests good but fails to perform satisfactorily in service for no apparent reason, the following are some of the more important factors that may point to the cause of the trouble.

1. Vehicle accessories inadvertently left on overnight to cause a discharge condition.
2. Slow speed driving of short duration, to cause an undercharged condition.
3. A vehicle electrical load exceeding the generator capacity.

4. Defect in the charging system such as high resistance, slipping fan belt, faulty generator or voltage regulator.

5. Battery abuse, including failure to keep the Battery top clean, cable attaching bolts clean and tight, and improper addition of water to the cells.

## INSTALLING BATTERIES

To install a Battery Properly, it is important to observe the following precautions:

- Connect grounded terminal of Battery last to avoid short circuits which may damage the electrical system.

Do not connect primary lead until secondary negative cable wire has been grounded to sheet metal.

- Be sure there are no foreign objects in the carrier, so that the new Battery will rest properly in the bottom of the carrier.

- Tighten the hold-down evenly until snug (60-80 in. lbs.). Do not draw down tight enough to distort or crack the case or cover.

- Be sure the cables are in good condition and the terminal bolts are clean and tight. Make sure the ground cable is clean and tight at engine block or frame.

- Torque cable connections at battery to 60-90 pound inches.

- Check polarity to be sure the Battery is not reversed with respect to the charging system.

## JUMP STARTING WITH AUXILIARY (BOOSTER) BATTERY

Both booster and discharged battery should be treated carefully when using jumper cables. Follow exactly the procedure outlined below, being careful not to cause sparks:

1. Set parking brake and place transmission in "PARK." Turn off lights, heater and other electrical loads.

2. Remove vent caps from both the booster and the discharged batteries. Lay a cloth over the open vent wells of each battery. These two actions help reduce the explosion hazard always present in either battery when connecting "live" booster batteries to "dead" batteries.

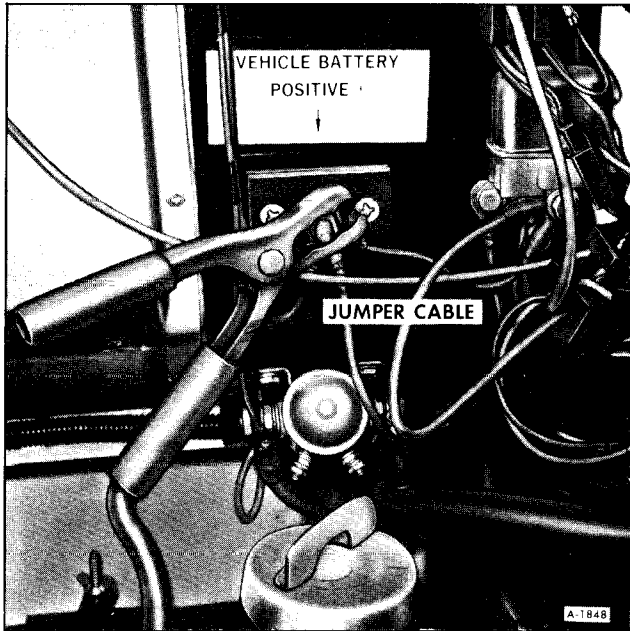

Figure 9—Connecting Jumper Cable to "Vehicle Battery Positive" Stud

3. Attach one end of one jumper cable to the positive terminal of the booster battery (identified by a red color "+" or "P" on the battery case, post or clamp) and the other end of same cable to positive terminal junction block stud NUT, marked "VEHICLE BATTERY POSITIVE." This is located behind the right access door above the batteries. Do NOT permit vehicles to touch each other, as this could establish a ground connection and counteract the benefits of this procedure. (figure 9)

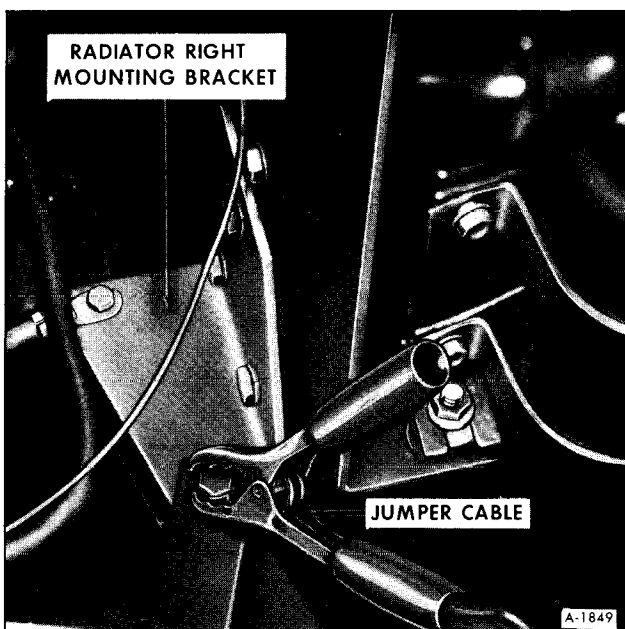

Figure 10—Connecting Jumper Cable to Right Radiator Mounting Bracket

4. Attach one end of the remaining negative cable to the negative terminal (black color, "-" or "N") of the booster battery, and the other end to the right radiator mounting bracket (do not connect directly to negative post of dead battery). Make sure that clamps from one cable do not inadvertently touch the clamps on the other cable. Do not lean over the battery when making this connection. (figure 10)

Reverse this sequence exactly when removing the jumper cables. Re-install vent caps and throw cloths away as the cloths may have corrosive acid on them.

**CAUTION:** Any procedure other than the preceding could result in: (1) personal injury caused by electrolyte squirting out the battery vents, (2) personal injury or property damage due to battery explosion or electrical burns, (3) damage to the charging system of the booster vehicle or of the immobilized vehicle.

## SAFETY PRECAUTIONS

When Energizers are being charged, an explosive gas mixture forms in each cell. Part of this gas escapes through the holes in the vent plugs and may form an explosive atmosphere around the energizer itself if ventilation is poor. This explosive gas may remain in or around the energizer for several hours after it has been charged. Sparks or flames can ignite this gas causing an internal explosion which may shatter the energizer.

The following precautions should be observed to prevent an explosion:

1. Do not smoke near energizers being charged or which have been very recently charged.
2. Do not break live circuits at the terminals of energizers because a spark usually occurs at the point where a live circuit is broken. Care must always be taken when connecting or disconnecting booster leads or cable clamps on fast chargers. Poor connections are a common cause of electrical arcs which cause explosions.

## CHARGING PROCEDURES

Before charging an energizer the electrolyte level must be checked and adjusted if needed. Energizer charging consists of applying a charge rate in amperes for a period of time in hours. Thus, a 10-ampere charge rate for seven hours would be a 70

ampere-hour (A.H.) charging input to the battery. Charging rates in the three to 50 ampere range are generally satisfactory. No particular charge rate or time can be specified for an energizer due to the following factors:

1. The size, or electrical capacity in ampere-hours (A.H.), of the Energizer.

**EXAMPLE:** A completely discharged 70 A.H. energizer requires almost twice the recharging as a 40 A.H. ENERGIZER.

2. Temperature of the energizer electrolyte.

**EXAMPLE:** About two hours longer will be needed to charge a 0°F. energizer than a 80°F. energizer.

3. Energizer state-of-charge at the start of the charging period.

**EXAMPLE:** A completely discharged energizer requires twice as much charge in ampere-hours as a one-half charged energizer.

Energizer age and condition.

**EXAMPLE:** An energizer that has been subjected to severe service will require up to 50% more ampere-hour charging input than a relatively new energizer.

The following basic rule applies to any energizer charging situation.

“Any energizer may be charged at any rate in amperes for as long as spewing of electrolyte due to violent gassing does not occur, and for as long as electrolyte temperature does not exceed 125°F. If spewing of electrolyte occurs, or if electrolyte temperature exceeds 120°F., the charging rate in amperes must be reduced or temporarily halted to avoid damage to the Energizer.

The energizer is fully charged when over a two-hour period at low charging rate in amperes all cells are gassing freely (not spewing liquid electrolyte), and no change in specific gravity occurs. The full charge specific gravity is 1.260-1.280, corrected for electrolyte temperature with the electrolyte level at the split ring, unless electrolyte loss has occurred due to age or overfilling in which case the specific gravity reading will be lower. For the most satisfactory charging, the lower charging rates in amperes are recommended.

at least 1.230 on all cells cannot be reached, the battery is not in an optimum condition and will not provide optimum performance; however, it may continue to provide additional service if it has performed satisfactorily in the past.

An “emergency boost charge”, consisting of a high charging rate for a short period of time, may be applied as a temporary expedient in order to crank an engine. However, this procedure usually supplies insufficient energizer reserve to crank a second and third time. Therefore, the “emergency boost charge” must be followed by a subsequent charging period of sufficient duration to restore the battery to a satisfactory state of charge. Refer to the charging guide in this section.

When out of the vehicle, the sealed side terminal battery will require adapters (figure 11) for the terminals to provide a place for attachment of the charging leads. Adapters are available through local parts service.

When the side terminal battery is in the vehicle, the studs provided in the wiring harness are suitable for attachment of the charger’s leads.

**CAUTION:** *Exercise care when attaching charger leads to side terminal studs to avoid contact with vehicle metal components which would result in damage to the energizer.*

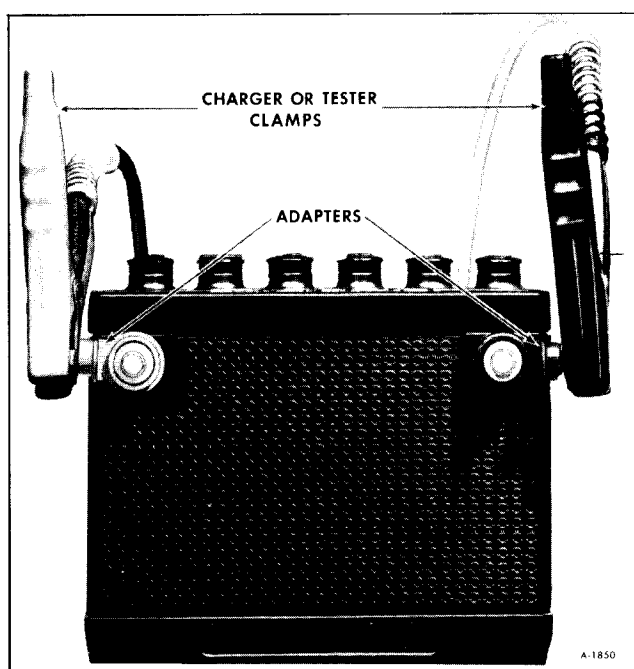

Figure 11—Charging Lead Adapters

If after prolonged charging a specific gravity of

## CHARGING GUIDE

### BATTERY MAINTENANCE

#### CARE OF ENERGIZER

##### Energizer Storage

Since the "dry charge" Energizer is vacuum sealed against the entrance of moisture, it may be stored for very long periods of time without detrimental effects so long as the seals remain unbroken. When storing a "dry charge" Energizer, the following procedures should be followed:

1. Keep the Energizer in its shipping carton until activated.
2. Do not stack the "dry charge" Energizer in cartons more than four high.
3. Rotate stocks regularly.
4. Maintain the storage area at 60°F or higher to aid activation.

A wet charged Energizer will not maintain its charged condition during storage, and must be recharged periodically. During storage, even though the Energizer is not in use, a slow reaction takes place between the chemicals inside the Energizer which causes the Energizer to lose charge and "wear out" slowly. This reaction is called "self-discharge." The rate at which self-discharge occurs varies directly with the temperature of the electrolyte.

Note that an Energizer stored in an area at 100°F for 60 days has a much lower specific gravity and

consequently a lower state of charge than one stored in an area at 60°F for the same length of time.

To minimize self-discharge, a wet Energizer should be stored in as cool a place as possible, provided the electrolyte does not freeze.

A wet Energizer which has been allowed to stand idle for a long period of time without recharging may become so badly damaged by the growth of lead sulfate crystals (sulfation) in the plates that it can never be restored to a normal charged condition. An Energizer in this condition not only loses its capacity but also is subject to changes in its charging characteristics. These changes, due to self-discharge, are often serious enough to prevent satisfactory performance in a vehicle.

Periodic recharging, therefore, is necessary to maintain a wet charged Energizer in a satisfactory condition while in storage. See paragraph "Charging Wet Energizer in Storage."

##### Charging Wet Energizer in Storage

Before placing an Energizer on charge, always check the electrolyte level and add water, as necessary, to bring the electrolyte up to the bottom of the split vent.

The Energizer should be brought to a fully charged condition every 30 days by charging as covered under heading of "Energizer Charging."

Trickle charging should not be used to maintain an Energizer in a charged condition when in storage.

#### RECOMMENDED RATE\* AND TIME FOR FULLY DISCHARGED CONDITION

**CAUTION: EXERCISE CARE WHEN ATTACHING CHARGER LEADS TO SIDE TERMINAL STUDS TO AVOID CONTACT WITH VEHICLE METAL COMPONENTS WHICH COULD RESULT IN DAMAGE TO THE ENERGIZER.**

Watt Rating	5 Amperes	10 Amperes	20 Amperes	30 Amperes	40 Amperes	50 Amperes
Below 2450	10 Hours	5 Hours	2-1/2 Hours	2 Hours		
2450-2950	12 Hours	6 Hours	3 Hours	2 Hours	1-1/2 Hours	
Above 2950	15 Hours	7-1/2 Hours	3-1/4 Hours	2 Hours	1-3/4 Hours	1-1/2 Hours

\* Initial rate for constant voltage taper rate charger.

To avoid damage, charging rate must be reduced or temporarily halted if:

1. Electrolyte temperature exceeds 125°F.
2. Violent gassing or spewing of electrolyte occurs.

Battery is fully charged when over a two hour period at a low charging rate in amperes all cells are gassing freely and no change in specific gravity occurs. For the most satisfactory charging, the lower charging rates in amperes are recommended. Full charge specific gravity is 1.260-1.280 corrected for temperature with electrolyte level at split ring.



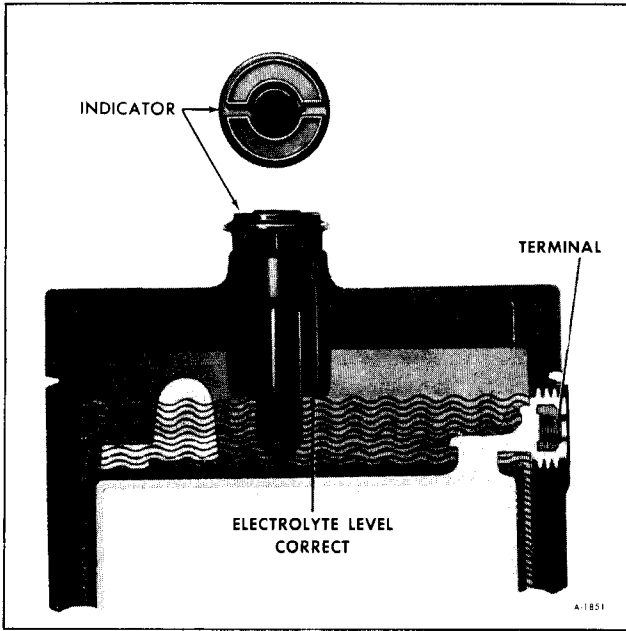

Figure 12—Electrolyte at Proper Level

The low charge rate method applied every 30 days is the best method of maintaining a wet charged Energizer in a fully charged condition without damage.

**Electrolyte Freezing**

The freezing point of electrolyte depends on its specific gravity. The following table gives the freezing temperatures of electrolyte at various specific gravities.

Since freezing may ruin a wet Energizer, it should be protected against freezing by keeping it in a charged condition. This is true whether the wet Energizer is in storage or in service. Antifreeze should never be added to the Energizer to prevent it from freezing as this practice is very harmful.

**Electrolyte Level Indicator**

The Energizer features an electrolyte level indicator, which is a specially designed vent plug with a transparent rod extending through the center. When the electrolyte is at the proper level, the lower tip of the rod is immersed, and the exposed top of the rod will appear very dark (figure 12) when the level falls below the tip of the rod, the top will glow (figure 13).

See NOTE on page 6Y-1.

Value of Specific Gravity Corrected to 80°F.	Freezing Temp. Deg. F.	Value of Specific Gravity Corrected to 80°F.	Freezing Temp. Deg. F.
1.100	18	1.220	-13
1.120	13	1.240	-50
1.140	8	1.260	-75
1.160	1	1.280	-92
1.180	-6	1.300	-95
1.200	-17		

The indicator reveals at a glance if water is needed, without the necessity of removing the vent plugs.

The Level Indicator is used on only one cell (second cell cap from positive terminal) because when the electrolyte level is low in one cell, it is normally low in all cells. Thus when the indicator shows water is needed, check the level in all six cells.

An alternate method of checking the electrolyte level is to remove the vent plug and visually observe the electrolyte level in the vent well. The bottom of the vent well features a split vent which will cause the surface of the electrolyte to appear distorted when it makes contact. The electrolyte level is correct when the distortion first appears at the bottom of the split vent (figure 14).

**Electrolyte Level**

The electrolyte level in the Energizer should be checked regularly. In hot weather, particularly during trip driving, checking should be more frequent because of more rapid loss of water. If the electrolyte level is found to be low, then colorless, odorless,

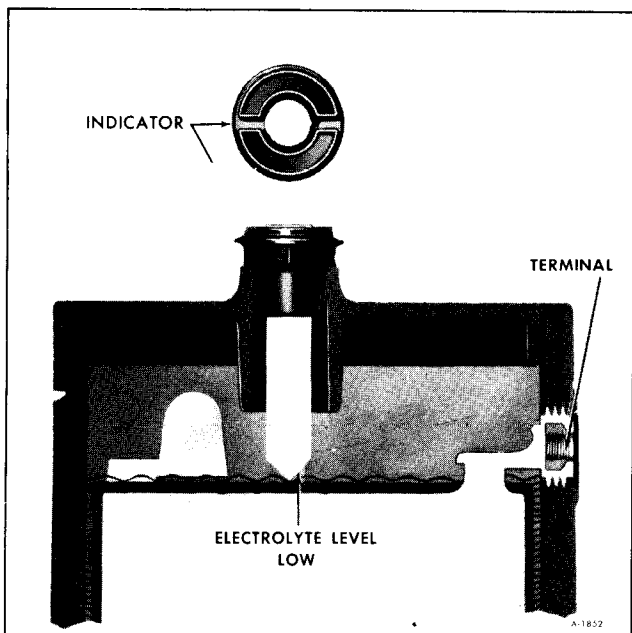

Figure 13—Electrolyte at Low Level

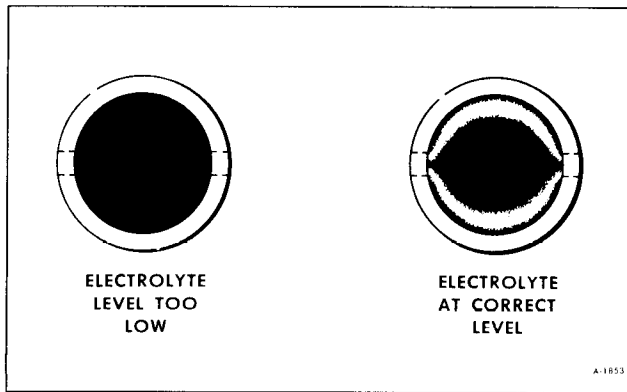

Figure 14-View Inside Vent Well

drinking water should be added to each cell until the liquid level rises to the split vent located in the bottom of the vent well. **DO NOT OVERFILL** because this will cause loss of electrolyte resulting in poor performance, short life, and excessive corrosion.

**CAUTION:** *During service only water should be added to the Battery, not electrolyte.*

The liquid level in the cells should never be allowed to drop below the top of the plates, as the portion of the plates exposed to air may be permanently damaged with a resulting loss in performance.

### Water Usage

Excessive usage of water indicates the Battery is being overcharged. The most common causes of overcharge are high Battery operating temperatures, too high a voltage regulator setting, poor regulator ground wire connection. Normal Battery water usage is approximately one to two ounces per month per battery.

### Carrier and Hold-Down

The Energizer carrier and hold-down should be clean and free from corrosion before installing the Battery. The carrier should be in sound mechanical condition so that it will support the Battery securely and keep it level.

To prevent the Battery from shaking in its carrier, the wing nuts should be tight (60-80 in. lbs.). However, the wing nuts should not be tightened to the point where the Battery case or cover will be placed under a severe strain.

### Cleaning

The external condition of the Energizer should be checked periodically for damage such as cracked cover, case and vent plugs or for the presence of dirt and corrosion. The Energizer should be kept clean. An accumulation of acid film and dirt may permit current to flow between the terminals, which will slowly discharge the Battery. For best results when cleaning Energizers, wash first with a diluted ammonia or a soda solution to neutralize any acid present; then flush with clean water. Care must be taken to keep vent plugs tight, so that the neutralizing solution does not enter the cells.

### SELECTING A REPLACEMENT ENERGIZER

Long and troublefree service can be more assured when the capacity or wattage rating of the replacement Energizer is at least equal to the wattage rating of the Energizer originally engineered for the application by the manufacturer.

The use of an undersize Energizer may result in poor performance and early failure. Energizer power shrinks while the need for engine cranking power increases with falling temperatures. Sub zero temperatures reduce capacity of a fully charged Energizer to 45% of its normal power and at the same time increase cranking load to 3-1/2 times the normal warm weather load.

Hot weather can also place excessive electrical loads on the Energizer. Difficulty in starting may occur when cranking is attempted shortly after a hot engine has been turned off or stalls. In fact, modern high compression engines can be as difficult to start under such conditions as on the coldest winter day. Consequently, good performance can be obtained only if the Energizer has ample capacity to cope with these conditions.

An Energizer of greater capacity should be considered if the electrical load has been increased through the addition of accessories or if driving conditions are such that the generator cannot keep the Energizer in a charged condition.

On applications where heavy electrical loads are encountered, a higher output generator that will supply a charge during low speed operation may be required to increase Energizer life and improve Energizer performance.

## BATTERY SPECIFICATIONS

	Type
Main (Automotive) Bat. ....	E5000 R91
Auxiliary (Living Area) Bat.....	E5000 R91
Motor Generator Bat. ....	E3000 Y87
E5000 R91 Rated 3350 Watts @ 0°F.	
E3000 Y87 Rated 2300 Watts @ 0°F.	

Part No.	1980224	1980199
Make .....	Delco-Remy	Delco-Remy
Model No. ....	E5000	E3000
Catalog .....	R91	Y87
Volts .....	12	12
No. of Plates Per Cell .....	13	11
Cranking Power @ 0° F. (Watts).....	3350	2300
Amp. Hr. Capacity @ 20 Hr. Rate .....	73	45
Load Test Amp. * .....	220	130

\*Apply Load Indicated Then Read Voltage at End of 15 Seconds with Load Connected. Compare Voltage Reading with Voltages and Temperatures Shown in "Voltage and Temperature Chart" following.

### VOLTAGE AND TEMPERATURE CHART NO. 1

	80°F.	70°F.	60°F.	50°F.	40°F.	30°F.	20°F.	10°F.	0°F.
Electrolyte Temperature	9.6	9.6	9.5	9.4	9.3	9.1	8.9	8.7	8.5
Voltage Minimum—12-Volt									

NOTE: Voltage must not drop below minimum listed at given temperature when battery is subjected to the proper Load for 15 seconds and is 1.200 specific gravity at 80°F. or more.

## GENERATING SYSTEM

### GENERAL DESCRIPTION

The 61-amp. (10 SI type 100) generator illustrated in Figure 15 and the 80-amp. (27 SI type 100) generator illustrated in Figure 16 feature a solid state regulator mounted inside the generator slip ring end frame. All regulator components are enclosed in a solid mold. This unit, along with the brush holder assembly, is attached to the slip ring end frame. The regulator voltage setting is not adjustable.

The generator rotor bearings contain a supply of lubricant sufficiently adequate to eliminate the need for periodic lubrication. Two brushes carry current through two slip rings to the field coil. The stator windings are assembled on the inside of a laminated core that forms part of the generator frame. A rectifier bridge connected to the stator windings contains six diodes, and electrically changes the stator A.C. voltages to a D.C. voltage which appears at the generator output terminal. Generator field current is

supplied through a diode trio connected to the stator windings. A capacitor, or condenser, mounted in the end frame protects the rectifier bridge and diode trio from high voltages, and suppresses radio noise.

### OPERATING PRINCIPLES

A typical schematic wiring diagram of the 61-, and 80-amp integral type charging system is shown in Figure 17. The basic operating principles are explained as follows:

When ignition switch is closed, current from the battery flows through the resistor to generator No. 1 terminal, through resistor R1, diode D1, and the base-emitter of transistor TR1 to ground, then back to the battery. This turns on transistor TR1, and current flows through the generator field coil and TR1 back to the battery. The ignition resistor

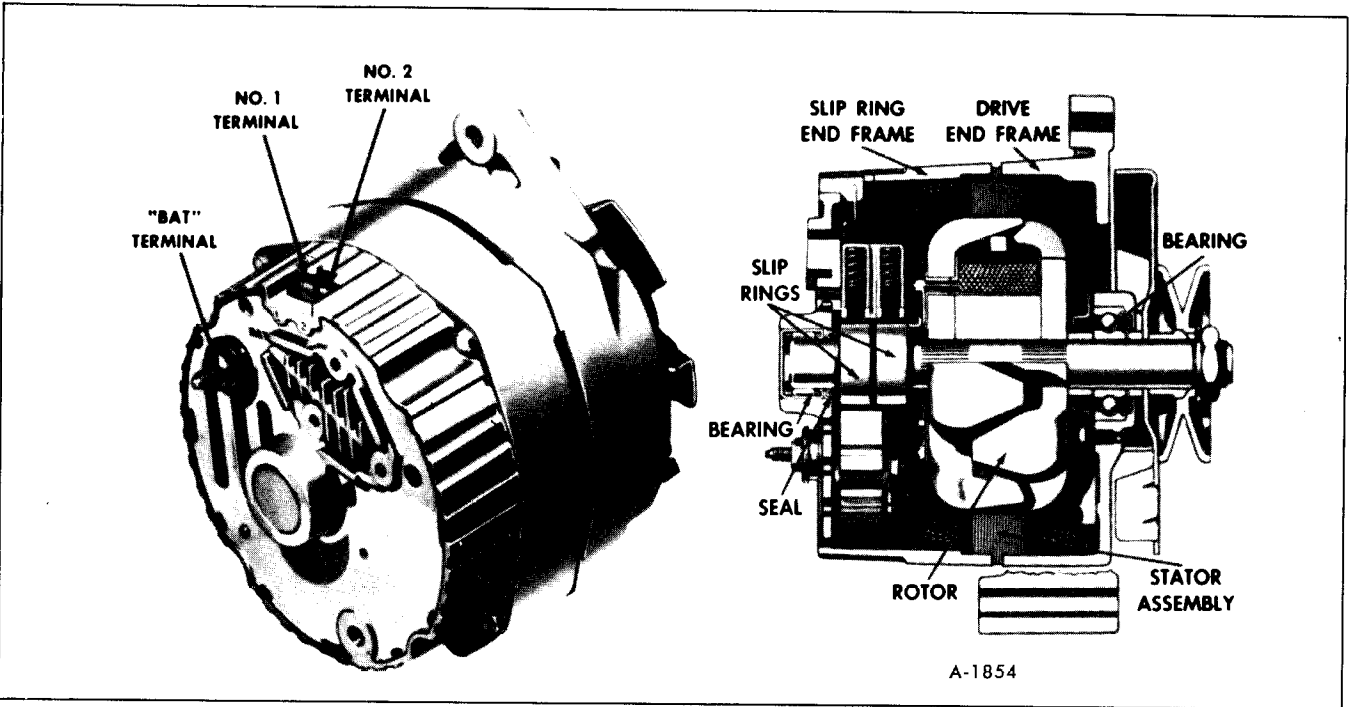

Figure 15-61 - Amp. Integral Type AC Generator

reduces total circuit resistance to provide higher field current for initial voltage build-up.

With generator operating, A.C. voltages are generated in the stator windings, and the stator sup-

plies D.C. field current through the diode trio, the field, TR1, and then through the grounded diodes in the rectifier bridge back to the stator. The six diodes in the rectifier bridge change the stator A.C. voltages to a D.C. voltage which appears between ground and

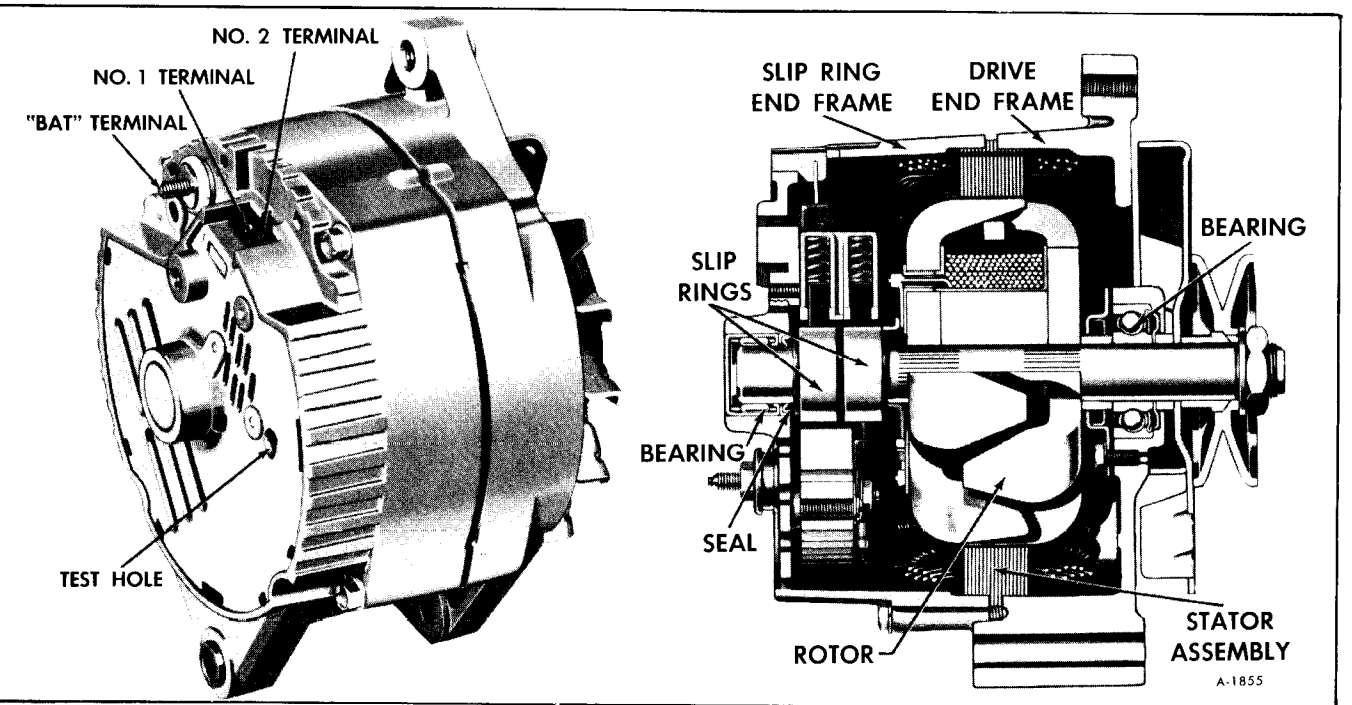

Figure 16-80 - Amp. Integral Type AC Generator

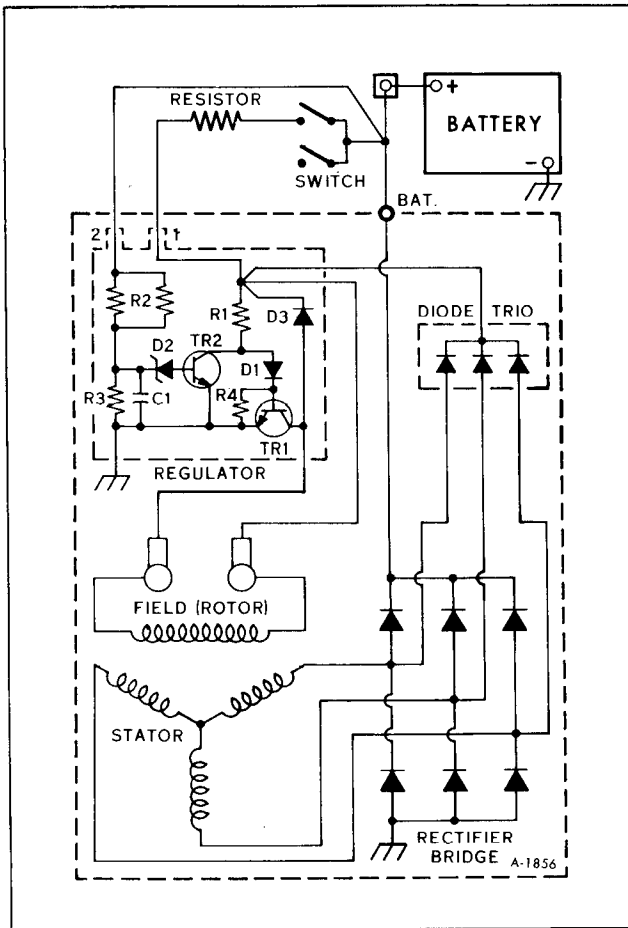

Figure 17—Schematic Diagram of Generating System (Typical)

generator "BAT" terminal. As generator speed increases, current is provided for charging the battery and operating electrical accessories.

The No. 2 terminal on the generator is always connected to the battery, but the discharge current is limited to a negligible value by the high resistances of R2 and R3. As generator speed and voltage increase, the voltage between resistors R2 and R3 increases to the point where zener diode D2 conducts. Transistor TR2 then turns on and TR1 turns off. With TR1 off, field current and system voltage decrease, and D2 blocks current flow, causing TR1 to turn back on. The field current and system voltage increase. This cycle repeats many times per second to limit generator voltage to a pre-set value.

Capacitor C1 smooths out the voltage across R3, resistor R4 prevents excessive current through TR1 at high temperatures, and diode D3 prevents high induced voltages in the field windings when TR1 turns off.

## GENERATING SYSTEM TROUBLE SYMPTOMS

Abnormal operation of the generating system is usually indicated by one or more of the following symptoms:

1. Battery undercharged (low specific gravity of electrolyte).
2. Battery using an excessive amount of water, indicating an extremely high charging rate.
3. Excessive generator noise or vibration.
4. Failure of indicator lamp to illuminate when ignition switch is turned on (engine not running).
5. Indicator lamp continues to glow with engine running.
6. Indicator lamp fails to go out when ignition or control switch is turned off.

## GENERATOR ON-VEHICLE TESTS

The following is a list of the most common generator defects encountered:

1. Open or shorted generator diodes.
2. Open, shorted, or grounded stator winding.
3. Open, shorted, or grounded field winding.
4. Worn generator brushes.
5. Excessive generator noise.

Generator diodes and stator windings should be checked as explained under "Generator Output Test" later in this section. If a defect is indicated by this test, remove generator and repair.

Excessive generator noise is usually the result of one or more of the following:

1. Brush "squeal" caused by a hard spot on one of the brushes or rough or dirty slip rings. To check for brush "squeal," remove generator drive belt and spin generator drive pulley by hand. Lift brushes off slip rings and spin drive pulley again. If noise disappears, clean and inspect slip rings and replace brushes if worn.
2. Dry or rough bearings in end frame.

## GENERATING SYSTEM DIAGNOSIS

### BATTERY UNDERCHARGED

### BATTERY OVERCHARGED

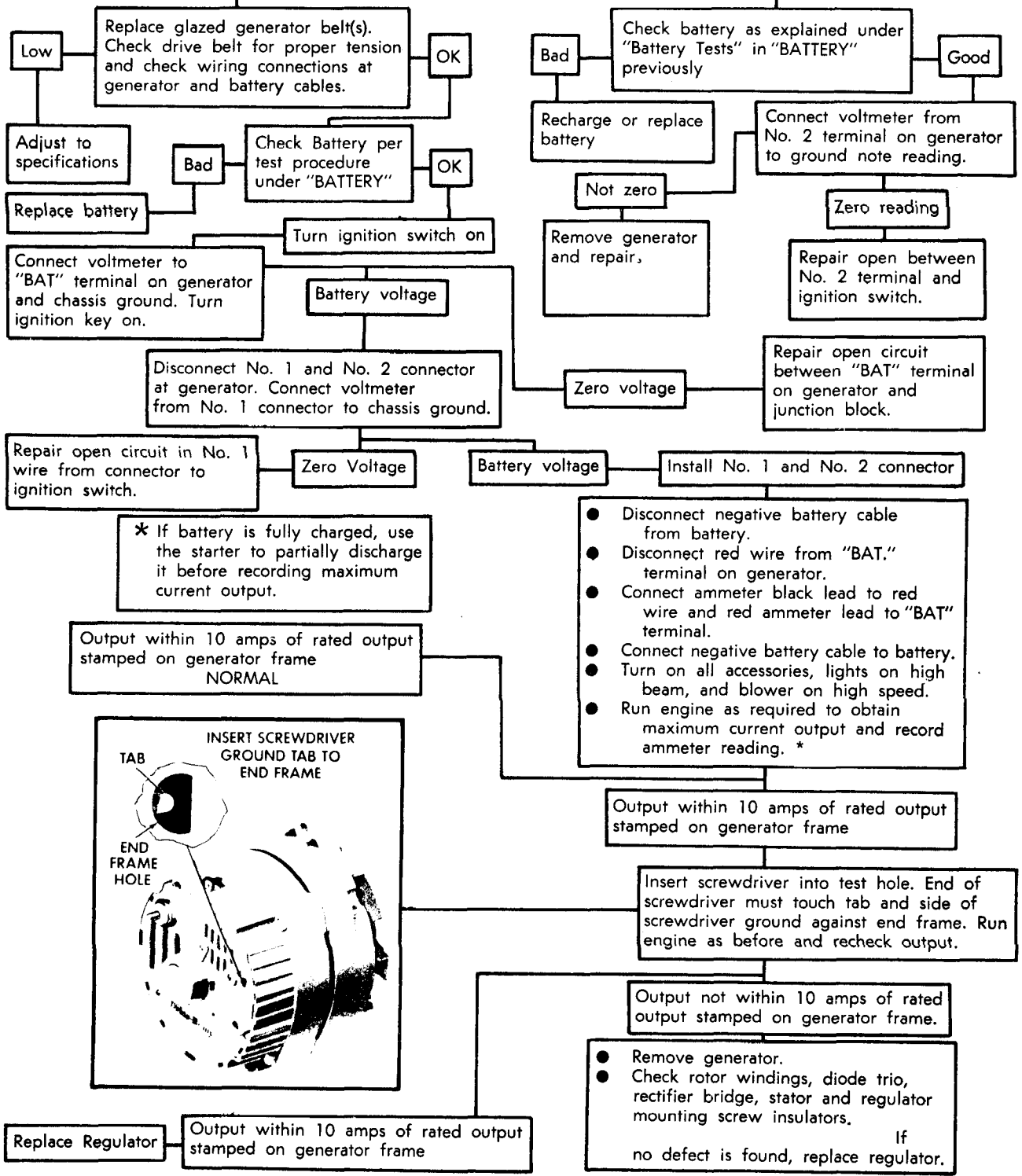

Generating System Diagnosis

**CAUTION:** *Dry or rough bearings may be the result of over-tightening generator drive belt(s), loose generator mountings, or an unbalanced generator fan or pulley.*

3. A defective diode or stator resulting in an electrical unbalance.

To check for a defective diode or stator, perform "Generator Output Test" explained later in this section. If a defect is indicated by this test, remove generator and repair.

## STATIC CHECK

Before making any electrical checks, visually inspect all connections, including slip-on connectors, to make sure they are clean and tight. Inspect all wiring for cracked, frayed, or broken insulation. Be sure generator mounting bolts are tight and unit is properly grounded. Check for loose fan belt.

## UNDERCHARGED BATTERY CONDITION CHECK

This condition, as evidenced by slow cranking and low specific gravity readings, can be caused by one or more of the following conditions:

1. Insure that the undercharged condition has not been caused by accessories having been left on for extended periods.

2. Check the drive belt for proper tension.

3. Check battery. Test is not valid unless battery is good and fully charged.

4. Inspect the wiring for defects. Check all connections for tightness and cleanliness, including the slip connectors at the generator and fire wall, and the cable clamps and battery posts:

5. With ignition switch on connect a voltmeter from generator "BAT" terminal to ground. A zero reading indicates an open between voltmeter connection and battery. Also, disconnect wiring harness at generator No. 1 and No. 2 terminals, and connect voltmeter from No. 1 harness terminal to ground. A zero reading indicates an open between voltmeter connection and battery. Reconnect harness to No. 1 and No. 2 terminals.

**NOTE:** If previous Steps 1 through 5 check satisfactorily, check generator as follows:

6. Connect a voltmeter in the circuit at the "BAT" terminal of the generator.

7. Operate engine at moderate speed (approximately 1500-2000 rpm) and turn on electrical loads (high beam headlights, windshield wiper, heater or A/C blower, radio, etc.).

**NOTE:** Without sufficient electrical load to demand maximum generator output the following voltage check is invalid.

8. Observe voltmeter reading:

- a. If reading is 12.8 volts or more, generator is not defective. Turn off electrical loads, stop engine and disconnect test equipment. Recheck Steps 1 through 5.

- b. If reading is less than 12.8 volts, ground field winding by inserting a screwdriver into the test hole in the end frame (figure 18).

**CAUTION:** *Tab is within 3/4-inch of casting surface. Do not force screwdriver deeper than 1-inch into end frame.*

- (1) If voltage increases (13 volts and above) regulator is defective and must be replaced. Repeat Steps 7 and 8 after new regulator unit has been installed.

- (2) If voltage does not increase significantly remove generator and repair.

9. Turn off electrical loads, shut off engine and disconnect all test equipment.

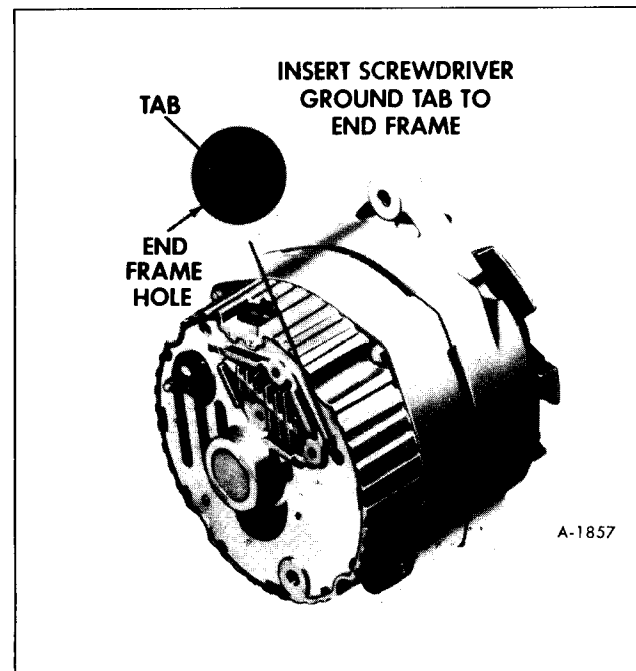

Figure 18—End View of Generator (Typical)

## OVERCHARGED BATTERY CONDITION CHECK

1. Determine condition of battery. Test is not valid if battery is not good and fully charged.

2. Connect a voltmeter from generator No. 2 terminal to ground. If reading is zero, No. 2 lead circuit is open, which will cause an overcharged condition.

3. If battery and No. 2 lead circuit check good, but an obvious overcharge condition exists as evidenced by excessive battery water usage, proceed as follows:

a. Remove the generator, then remove four thru-bolts, and separate the drive end frame and rotor assembly from the stator assembly by prying apart with a screwdriver at the stator slot.

b. Connect ohmmeter using lowest range scale from brush lead clip to end frame as shown in Step 1 in Figure 19 then reverse lead connections.

c. If both readings are zero, either the brush lead clip is grounded or regulator is defective.

d. A grounded brush lead clip can result from omission of insulating washer (figure 19) omission of insulating sleeve over screw, or damaged insulating sleeve. Remove screw to inspect sleeve. If satisfactory, replace regulator.

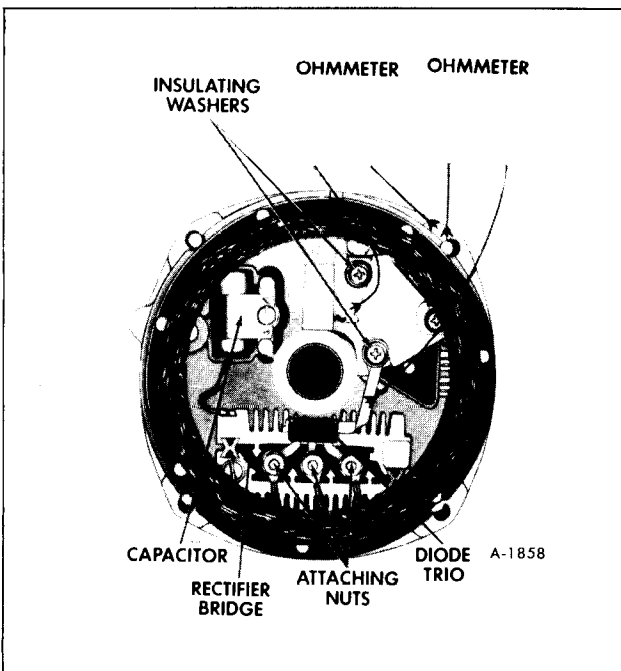

Figure 19-Slip Ring End Frame

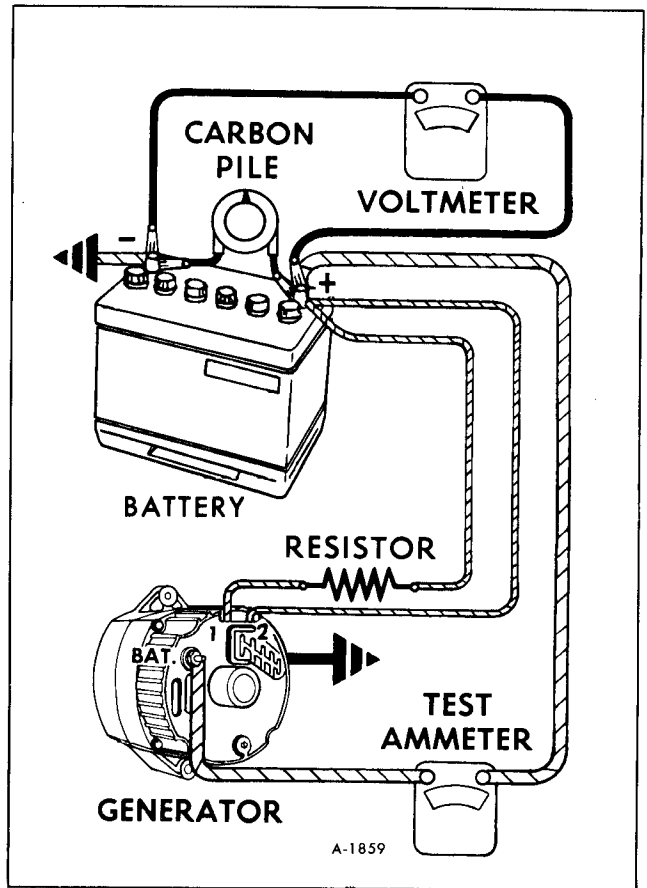

Figure 20-Connections for Testing Generator Output

e. Assemble generator, then check for rated output as explained later in this section.

## GENERATOR OUTPUT TEST

To check the generator in a test stand, proceed as follows:

1. Make connections as shown in Figure 20 except leave the carbon pile disconnected. Use a fully charged battery and a 10-ohm resistor rated at 6 watts or more between the generator No. 1 terminal and the battery.

**NOTE:** Battery must be fully charged when making this check. An undercharged battery would be charged during the test procedure, thus producing varied ammeter and voltmeter readings.

2. Slowly increase generator speed and observe the voltage.

3. If voltage is uncontrolled with speed and increases above 16 volts, check for a grounded brush lead clip as explained previously under "Over-



charged Battery,” Step 3. If not grounded, replace the regulator.

4. Connect the carbon pile as shown in Figure 20.

5. Operate the generator at moderate speed as required and adjust carbon pile as required to obtain maximum current output.

6. If output is within 10% of rated output, as listed in “Specifications” at end of this section, generator is good.

7. If output is not within 10% of rated output, ground the generator field (figure 18)

**CAUTION:** Tab is within 3/4-inch of casting surface. Do not force screwdriver deeper than 1-inch into end frame.

8. Operate generator at moderate speed and adjust carbon pile as required to obtain maximum output.

9. If output is within 10% of rated output, replace the regulator (figure 19).

10. If output is not within 10% of rated output, check the field winding, diode trio, rectifier bridge and stator as previously covered.

## PRECAUTIONS

Observe the following precautions when performing service operations on the alternating current generating system. Failure to observe these precautions may result in serious damage to the charging system.

**NOTE:** A basic wiring diagram showing lead connections is shown in Figure 21.

1. Electrical system is **NEGATIVE GROUND**. Connecting the battery with positive terminal grounded will result in severe damage to generator, battery and battery cables.

2. **DO NOT** ground the field circuit at generator.

3. Never operate generator with open circuit, that is, with output wire disconnected from terminal and with field circuit externally energized. Be absolutely sure all connections in circuit are secure.

4. When using a booster battery, connect leads as explained under “Jump Starting with Auxiliary (Booster) Battery” in BATTERY (Sec. 6Y).

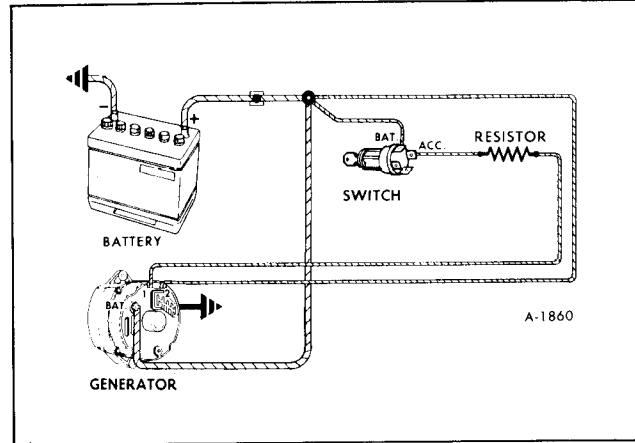

Figure 21—Typical Lead Connections

5. Disconnect battery leads while charging batteries. Do not use a fast charger as a booster for starting the engine. When attaching battery charger leads to battery, connect charger positive lead to battery positive terminal and connect charger negative lead to battery negative terminal.

6. Do not short across or ground any of the terminals in the charging circuit.

7. Do not attempt to polarize the generator.

8. When working near generator or regulator, disconnect battery cable to prevent accidental grounding at generator terminals.

9. Always disconnect battery negative cables when replacing electrical system components. This eliminates accidental shorting at generator terminals where battery voltage is available.

10. Disconnect battery negative cables before welding on vehicle, since a reverse current from the welder may damage generator diodes as well as other electrical components.

11. Never replace the special resistance wire in harness connected to the ignition switch unless it is of same material and of same length (approx. 60 inches long). Generating system will not function without this wire. Wire is identified in Engine and Chassis Wiring Diagram (Back of Manual).

## GENERATOR REMOVAL

**NOTE:** Due to variations in design and equipment, the replacement procedures will vary accordingly. The removal and installation instructions following are intended only as a guide. Additional operations will be required on

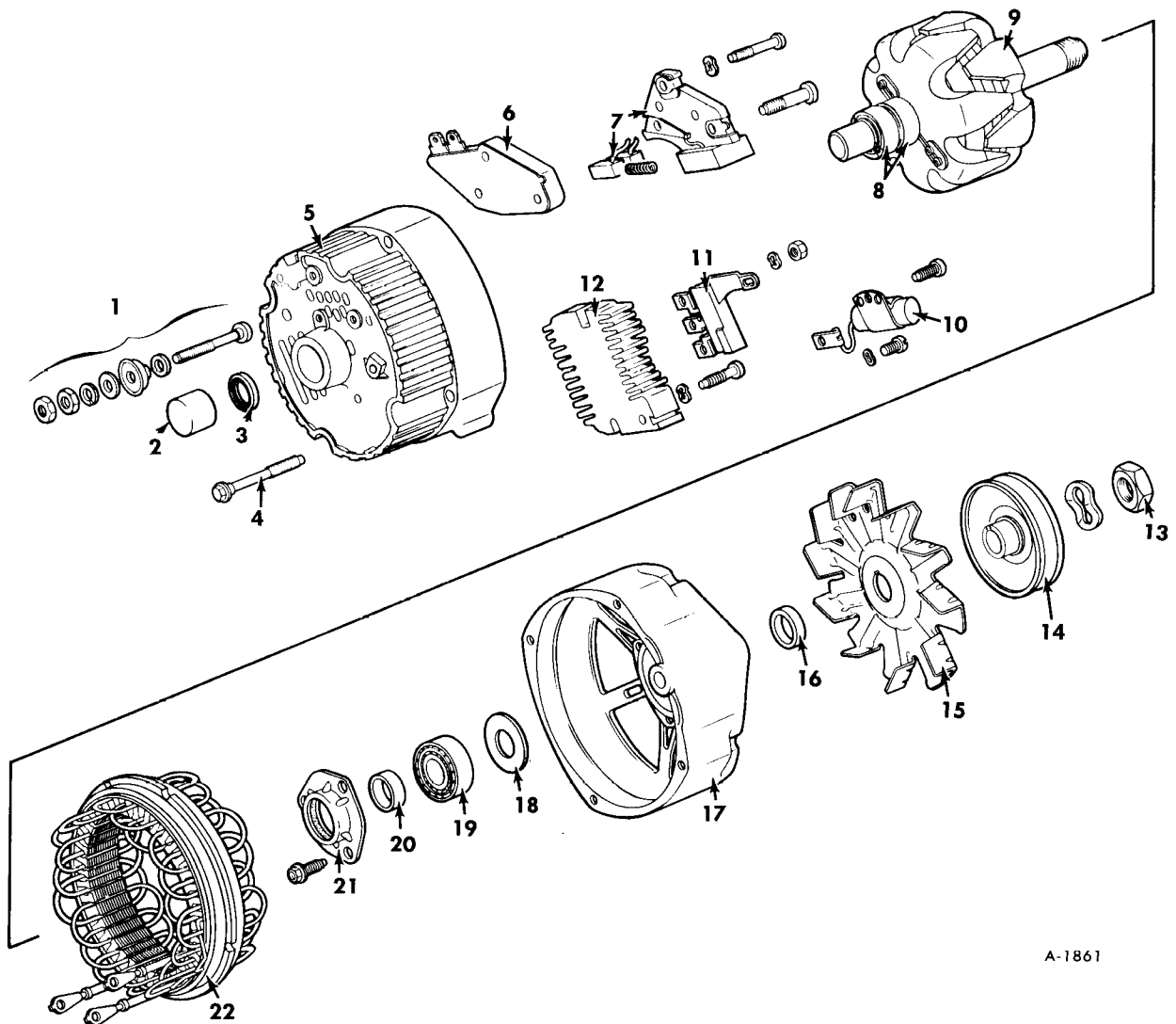

A-1861

- |                                  |                                  |
|----------------------------------|----------------------------------|
| 1. Battery Terminal              | 12. Bridge-Rectifier             |
| 2. Bearing-Roller, Slip Ring End | 13. Drive Shaft Nut              |
| 3. Seal                          | 14. Pulley                       |
| 4. Bolt-Thru                     | 15. Fan                          |
| 5. Frame-Slip Ring End           | 16. Drive Shaft Collar (Outside) |
| 6. Regulator                     | 17. Frame-Drive End              |
| 7. Brush Holder                  | 18. Washer-Grease Slinger        |
| 8. Slip Rings                    | 19. Bearing-Drive End            |
| 9. Rotor                         | 20. Drive Shaft Collar (Inside)  |
| 10. Capacitor                    | 21. Retainer Plate               |
| 11. Diode (Trio)                 | 22. Stator                       |

Figure 22-Delcotron Generator (Typical)

some vehicles to remove other equipment to permit access to generator, belts, and/or brackets.

1. Disconnect negative cables from batteries.
2. Depress lock on connector and pull connector out of socket on generator. Pull rubber boot off "BAT" terminal and remove terminal nut. Disconnect ground (GRD) terminal and remove wiring clip.
3. Loosen bolt in adjusting arm and mounting bracket. Move generator to loosen drive belt (or belts); remove belt(s) from generator pulley.
4. Remove the bolt attaching the generator to mounting bracket, remove adjusting arm bolt, then remove generator from engine.

## GENERATOR REPAIR

To repair the generator, observe the following procedure:

### DISASSEMBLY (FIGURE 22)

To disassemble the generator, take out the four thru-bolts, and separate the drive end frame and rotor assembly from the stator assembly by prying apart with a screwdriver at the stator slot. A scribe mark will help locate the parts in the same position during assembly. After disassembly, place a piece of tape over the slip ring end frame bearing to prevent entry of dirt and other foreign material, and also place a piece of tape over the shaft on the slip ring end. If brushes are to be reused, clean with a soft dry cloth.

**CAUTION:** Use pressure sensitive tape and not friction tape which would leave a gummy deposit on the shaft.

To remove the drive end frame from the rotor, place the rotor in a vise and tighten only enough to permit removal of the shaft nut. **CAUTION:** Avoid excessive tightening as this may cause distortion of the rotor. Remove the shaft nut, washer, pulley, fan, and the collar, and then separate the drive end frame from the rotor shaft.

### ROTOR FIELD WINDING CHECKS

To check for opens, connect the test lamp or ohmmeter to each slip ring. If the lamp fails to light,

or if the ohmmeter reading is high (infinite), the winding is open (figure 22).

The winding is checked for short circuits or excessive resistance by connecting a battery and ammeter in series with the edges of the two slip rings. Note the ammeter reading and refer to Generator Specifications. An ammeter reading above the specified value indicates shorted windings; a reading below the specified value indicates excessive resistance. An alternate method is to check the resistance of the field by connecting an ohmmeter to the two slip rings (figure 22). If the resistance reading is below the specified value, the winding is shorted; if above the specified value the winding has excessive resistance.

The specified resistance value can be determined by dividing the voltage by the current given in Generator Specifications. Remember that the winding resistance and ammeter readings will vary slightly with winding temperature changes. If the rotor is not defective, but the generator fails to supply rated output, the defect is in the diode trio, rectifier bridge or stator.

### DIODE TRIO CHECK

The diode trio is identified in Figure 19. First, connect an ohmmeter using lowest range scale from diode trio long connector to end frame as shown in Step 2, Figure 19, then reverse lead connections. If both readings are the same, check for grounded brush lead clip caused by omission of insulating washer (figure 19), omission of insulating sleeve over screw, or damaged insulating sleeve. Remove screw to inspect sleeve. **If screw assembly is correct, and both ohmmeter readings are the same, replace regulator.**

To check the diode trio, remove it from the end frame assembly by detaching the three nuts, the attaching screw, and removing the stator assembly. Note that the insulating washer on the screw is assembled over the top of the diode trio connector. Connect an ohmmeter having a 1-1/2 volt cell, and using the lowest range scale, to the single connector and to one of the three connectors (figure 23). Observe the reading. Then reverse the ohmmeter leads to the same two connectors. If both readings are the same, replace the diode trio. A good diode trio will give one high and one low reading. Repeat this same test between the single connector and each of the other two connectors. Also, connect the ohmmeter to each pair of the three connectors (not illustrated). If any reading is zero, replace the diode trio.

**NOTE:** Figures 19 and 23 illustrate two diode trios differing in appearance. Either one of these diode trios may be used in these generators, and the two are completely interchangeable.

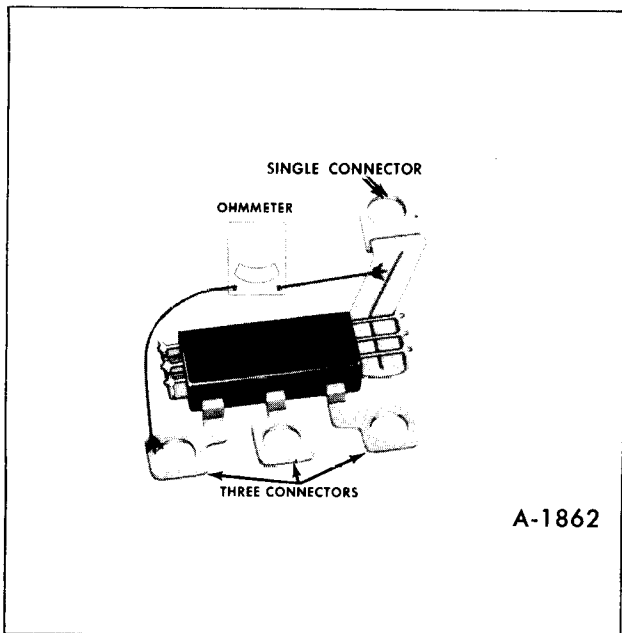

Figure 23—Diode Trio Check

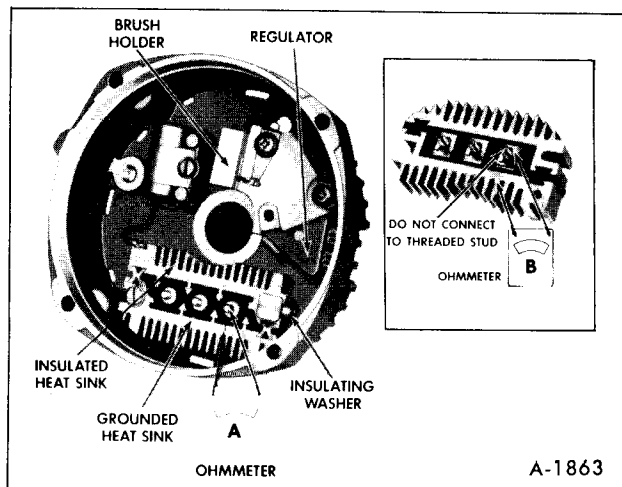

Figure 24—Rectifier Bridge Check

## STATOR CHECKS

The stator windings may be checked with a 110-volt test lamp or an ohmmeter. If the lamp lights, or if the meter reading is low when connected from any stator lead to the frame, the windings are grounded. If the lamp fails to light, or if the meter reading is high when successively connected between each pair of stator leads on 10-SI Series, the windings are open.

**NOTE:** Delta windings on 80-amp. generator cannot be checked for opens.

A short circuit in the stator windings is difficult to locate without laboratory test equipment due to the low resistance of the windings. However, if all other electrical checks are normal and the generator fails to supply rated output, shorted stator windings or an open delta winding on 80-amp. generator is indicated. Also, a shorted stator can cause the indicator lamp to be on with the engine at low speed.

## BRUSH HOLDER AND REGULATOR REPLACEMENT

After removing the three attaching nuts, the stator, and diode trio screw (figure 24) the brush holder and regulator may be replaced by removing the two remaining screws. Note the two insulators located over the top of the brush clips in Figure 19, and that these two screws have special insulating sleeves over the screw body above the threads. The third mounting screw may or may not have an insulating sleeve. If not, this screw must not be interchanged with either one of the other two screws, as a ground may result, causing no output or uncontrolled generator

## RECTIFIER BRIDGE CHECK

Note that the rectifier bridge has a grounded heat sink and an insulated heat sink connected to the output terminal. Also, note the insulating washer located between the insulated heat sink and end frame on 10-SI generators.

To check the rectifier bridge, connect the ohmmeter to the grounded heat sink and one of the three terminals, (figure 24). Connect to flat metal connector, and not onto threaded stud. Then reverse the lead connections to the grounded heat sink and same terminal. If both readings are the same, replace the rectifier bridge. A good rectifier bridge will give one high and one low reading. Repeat this same test between the grounded heat sink and the other two terminals, and between the insulated heat sink and each of the three terminals. This makes a total of six checks, with two readings taken for each check.

The ohmmeter check of the rectifier bridge, and of the diode trio as previously covered, is a valid and accurate check. Do not replace either unit unless at least one pair of readings is the same.

**CAUTION:** Do not use high voltage to check these units such as a 110 volt test lamp.

To replace the rectifier bridge, remove the attaching screws, and disconnect the capacitor lead. Note the insulator between the insulated heat sink and end frame (figure 24). Rectifier bridges may vary in appearance but are completely interchangeable in these generators.

output. Regulators may vary in appearance but are completely interchangeable in these generators.

## SLIP RING SERVICING

If the slip rings are dirty, they may be cleaned and finished with 400 grain or finer polishing cloth. Spin the rotor, and hold the polishing cloth against the slip rings until they are clean. **CAUTION:** The rotor must be rotated in order that the slip rings will be cleaned evenly. Cleaning the slip rings by hand without spinning the rotor may result in flat spots on the slip rings, causing brush noise.

Slip rings which are rough or out of round should be trued in a lathe to .002 inch maximum indicator reading. Remove only enough material to make the rings smooth and round. Finish with 400 grain or finer polishing cloth and blow away all dust.

## BEARING REPLACEMENT AND LUBRICATION

The bearing in the drive end frame can be removed by detaching the retainer plate screws, and then pressing the bearing from the end frame. If the bearing is in satisfactory condition, it may be reused, and it should be filled one-quarter full with Delco-Remy lubricant No. 1948791 or equivalent before reassembly. **CAUTION:** Do not overfill, as this may cause the bearing to overheat.

To install a new bearing, press in with a tube or collar that just fits over the outer race, with the bearing and slinger assembled into the end frame. It is recommended that a new retainer plate be installed if the felt seal in the retainer plate is hardened or excessively worn. Fill the cavity between the retainer plate and bearing with 1948791 lubricant.

The bearing in the slip ring end frame should be replaced if its grease supply is exhausted. No attempt should be made to re-lubricate and reuse the bearing. To remove the bearing from the slip ring end frame, press out with a tube or collar that just fits inside the end frame housing. Press from the outside of the housing towards the inside.

To install a new bearing, place a flat plate over the bearing and press in from the outside towards the inside of the frame until the bearing is flush with the outside of the end frame. Support the inside of the frame with a hollow cylinder to prevent breakage of the end frame. Use extreme care to avoid misalignment or otherwise placing undue stress on the bearing.

If the seal is separate from the bearing, it is recommended that a new seal be installed whenever the bearing is replaced. Press the seal in with the lip of the seal toward the rotor when assembled, that is, away from the bearing. Lightly coat the seal lip with oil to facilitate assembly of the shaft into the bearing.

## ASSEMBLY

Assembly is the reverse of disassembly.

Remember when assembling the pulley to secure the rotor in a vise only tight enough to permit tightening the shaft nut to 40-60 lb. ft. If excessive pressure is applied against the rotor, the assembly may become distorted. To install the slip ring end frame assembly to the rotor and drive end frame assembly, remove the tape over the bearing and shaft, and make sure the shaft is perfectly clean after removing the tape. Insert a pin through the holes to hold up the brushes. Carefully install the shaft into the slip ring end frame assembly to avoid damage to the seal. After tightening the thru-bolts remove the brush retaining pin to allow the brushes to fall down onto the slip rings.

## GENERATOR BENCH CHECK

To check the generator in a test stand, proceed as follows:

1. Make connections as shown in Figure 20 except leave the carbon pile disconnected.

**IMPORTANT:** Ground polarity of Energizer and generator must be the same. Use a fully charged Energizer or battery, and a 10 ohm resistor rated at six watts or more between the generator No. 1 terminal and the Energizer.

2. Slowly increase the generator speed and observe the voltage.

3. If the voltage is uncontrolled with speed and increases above 15.5 volts on a 12-volt system, check for a grounded brush lead clip as covered under heading of "OVERCHARGED ENERGIZER," Step 3. If not grounded, replace the regulator, and check field winding.

**NOTE:** The Energizer or battery must be fully charged when making this check.

4. If voltage is below 15.5 volts, connect the carbon pile as shown.

5. Operate the generator at moderate speed as required and adjust the carbon pile as required to obtain maximum current output.

6. If output is within 10 percent of rated output as stamped on generator frame, generator is good.

7. If output is not within 10 percent of rated output, keep Energizer or battery loaded with carbon pile, and ground generator field.

8. Operate generator at moderate speed and adjust carbon pile as required to obtain maximum output.

9. If output is within 10 percent of rated output, replace regulator as covered in "Regulator Replacement" section, and check field winding.

10. If output is not within 10 percent of rated output, check the field winding, diode trio, rectifier bridge, and stator as previously covered.

## GENERATOR INSTALLATION

1. Attach generator to mounting bracket and install adjusting arm. Tighten flange-type lock nuts securely.

2. Place drive belt(s) over generator drive pulley and adjust belt tension. Tighten mounting bolts and adjusting arm bolt when belt tension adjustment has been made. Refer to "Generator Drive Belt Tension Adjustment" later in this section.

3. Push the wiring harness connector into the socket making sure the lock on the connector engages the end frame. Place harness clip on ground terminal marked "GRD" and connect the ground wire to terminal.

4. Attach red wire to "BAT" terminal on generator and fit boot on terminal.

5. Perform "Generator Output Test" described earlier in this section to determine if generator is operating properly.

## GENERATOR DRIVE BELT

### TENSION ADJUSTMENT

Because of the higher inertia and load capacity of rotor used with A.C. generators, **PROPER BELT TENSION MUST BE MAINTAINED.**

All generators are pivot-base mounted with the belt tension adjustment arm at the top or bottom using belt tension tool J-23600 or other suitable tool to check tension on each individual belt. If tension is not within 70-80 lbs. (used belts) or 110-140 lbs. (new belts), loosen adjustment arm clamp bolt and move generator to obtain recommended tension.

**CAUTION:** *When adjusting belt tension, apply pressure at center of generator, never against either end frame.*

**NOTE:** On a new vehicle, or after having installed new belts, check tension of belt(s) twice in first 200 miles of operation. When making adjustment, examine belt(s) and replace if necessary.

A loose or broken drive belt will affect operation of generator. A drive belt that is too tight will place too much strain on bearings.

## GENERATING SYSTEM MAINTENANCE

Most charging system troubles show up as an undercharged or overcharged battery. Since the battery itself may be defective, it should be checked first to determine its condition. In the case of an undercharged battery, check for battery drain caused by ground or by accessories being left on.

At regular intervals, inspect generating system to locate and correct potential causes of trouble before generating system performance is affected.

1. Check generator drive belt tension and adjust if necessary. See procedure earlier under "Generator Drive Belt Tension Adjustment."

2. Check generator mounting and adjusting arm bolts and tighten as necessary.

3. Check all electrical connections for tightness and corrosion. Clean and tighten connections as necessary. Be sure wiring insulation is in good condition, and that all wiring is securely clipped to prevent chafing the insulation.

4. With engine running, listen for noise and check generator for vibration. If generator is noisy or vibrates excessively, it should be removed for inspection and repair.

5. Check battery electrolyte level and specific gravity. Replenish electrolyte level, as necessary.

## GENERATOR SPECIFICATIONS

Generator Model	(61 Amp.) 1102368	(80 Amp.) 1101015
Make .....	Delco-Remy .....	Delco-Remy
Series .....	10SI .....	27 SI
Type.....	100 .....	100
Rotation (Viewing Drive End) .....	CW .....	CW
Field Current at 80°F.		
Amps. ....	4.0-4.5	4.0-4.5
Volts .....	12 .....	12
Cold Output		
Specified Volts .....	(a) .....	(a)
Amps. ....	55 .....	74
Generator RPM (Approx.).....	5000 .....	5000
Rated Hot Output (Amps.) (b) .....	61 .....	80

(a) Voltmeter not needed for cold output check. Load battery with a carbon pile to obtain maximum output.

(b) Rated hot output at maximum operating speed.

## IGNITION SYSTEM

### GENERAL DESCRIPTION

The ignition system used on the Motor Home is the standard breaker point type consisting of a coil, condenser, distributor, switch, wiring, spark plugs and a source of electrical energy. The distributor contact points set, condenser, cam lubricator and spark plugs are the only system components that require periodic service. The remainder of the ignition system requires only periodic inspection to check the operation of the components, tightness of electrical connections, and condition of the wiring.

The distributor used is an external adjustment type and its function is to (1) cause a higher voltage surge from coil, (2) time these surges with regard to engine requirements through use of centrifugal and vacuum advance mechanisms, and (3) direct high voltage surges through distributor rotor, cap, and high tension wiring to the spark plugs.

The distributor houses the contact points that make and break the primary circuit, and also directs high voltage and current in proper sequence to the spark plugs. The contact point set is replaced as a complete assembly. The breaker lever spring tension and point alignment on the replacement set are factory adjusted, leaving only the dwell angle to be adjusted after installation.

The rotor located above the breaker plate assembly serves as a cover for the centrifugal advance mechanism, and distributes high voltage and current to fire the spark plugs. When the rotor is removed, the centrifugal advance mechanism should be inspected for lubricant. If necessary, a small amount of cam and bearing lubricant should be applied to the advance weights.

The ignition coil is an oil filled, hermetically sealed unit designed specifically for use with an external resistance. The number of turns in the primary winding results in a high inductance in this winding, which makes it possible for the coil to provide a higher secondary voltage output throughout the speed range. The primary current from the ignition switch passes through a resistance wire which lowers the voltage to approximately 8 volts. This lower voltage provides for longer contact life.

For optimum starting performance, the resistance is bypassed during cranking, thereby connecting the ignition coil directly to the battery. This provides full battery voltage at the coil and keeps ignition voltage as high as possible during cranking. The resistance is bypassed automatically through the ignition and starting switch when the switch is in the "Start" position.

The secondary ignition cables in the secondary or high tension system (coil to distributor and distributor to plugs) are resistant to grease, battery acid and road salt, and offers resistance to corona breakdown. Ignition cables have a multiple cloth thread core impregnated with a graphite solution to give the correct conductivity.

The spark plugs used are a resistor type plug. The plugs have a type number on the insulator which designates thread size as well as relative position of the plug in the heat range. The last digit of the type number indicates the heat range position of the plug. The higher the number the hotter the plug. Spark plugs should be replaced at least every 12 months or 12,000 miles depending on driving conditions with unleaded fuels or at 6 months or 6,000 miles with leaded fuels.

## THEORY OF OPERATION

The basic ignition system consists of the ignition coil, condenser, ignition distributor, ignition switch, low and high tension wiring, spark plugs, and a source of electrical energy (battery or generator). The ignition system has the function of producing high voltage surges and directing them to the spark plugs in the engine cylinders. The sparks must be timed to appear at the plugs at the correct instant near the end of the compression stroke with relation to piston position. The spark ignites the fuel-air mixture under compression so that the power stroke follows in the engine.

There are two separate circuits through the ignition system. One of these is the primary circuit which includes the ignition switch, primary winding of the ignition coil, distributor contact points and condenser. The other is the secondary or high tension circuit which includes the secondary winding of the ignition coil, the high tension lead, distributor cap, rotor and spark plugs.

The basic operation is described as follows: With the switch closed, current flows through the primary circuit, that is from the battery through the primary winding of the ignition coil and closed distributor contacts to ground, and then back to the battery. A cam mounted on the rotating distributor shaft causes the distributor contacts to open and close. When the contacts open, the current decreases very rapidly in the ignition coil primary winding, and a high voltage is induced in the coil secondary winding.

This high voltage is impressed through the distributor cap and rotor across one of the spark plugs. As the voltage establishes an arc across the spark plug electrodes, the air-fuel mixture in the cylinder is ignited to provide the power stroke.

The secondary electrons flow from the coil secondary winding, across the distributor rotor gap and spark plug gap, and then back to the secondary winding through ground, the battery and switch. The distributor contacts then reclose, and the cycle repeats. The next-firing spark plug then will be the one connected to the distributor cap insert that is aligned with the rotor when the contacts separate. With the engine running, current flows through the coil primary calibrated resistance wire; the other lead connected between the coil and solenoid terminal is a by-pass feature that will be covered in the section entitled "Ignition Coils".

When the contacts separate, a high voltage is induced in the coil primary winding. This voltage may be as high as 250 volts, which causes an arc to form across the distributor contacts. To bring the primary current to a quick controlled stop, and in order to greatly reduce the size of the arc and thereby insure prolonged contact point life, a capacitor (condenser) is connected across the distributor contacts.

## DISTRIBUTOR

The distributor has three jobs. First, it opens and closes the low tension circuit between the source of electrical energy and the ignition coil so that the primary winding is supplied with intermittent surges of current. Each surge of current builds up a magnetic field in the coil. The distributor then opens its circuit so that the magnetic field will collapse and cause the coil to produce a high voltage surge. The second job that the distributor has is to time these surges with regard to the engine requirements. This is accomplished by the centrifugal and vacuum advance mechanisms. Third, the distributor directs the high voltage surge through the distributor rotor, cap and high tension wiring to spark plug which is ready to fire.

The typical contact point type ignition distributor consists of a housing, shaft, centrifugal advance assembly, vacuum advance assembly, breaker plate assembly, capacitor or condenser, and rotor.

The cap, rotor, and high voltage leads in a distributor form a distribution system that conveys the high voltage surges to the spark plugs in correct sequence.

The breaker plate contains the breaker lever, contact support, and capacitor. When the breaker cam rotates, each cam lobe passes by and contacts the breaker lever rubbing block, separating the contact points and producing a high voltage surge in the ignition system. With every breaker cam revolution, one spark will be produced for each engine cylinder. Since each cylinder fires every other revolution in a



four-cycle engine, the distributor rotates at one-half engine speed.

The shaft and weight base assembly is fitted in suitable bearings made of such materials as cast iron, bronze, or iron. Centrifugal advance weights are pivoted on studs in the weight base, and are free to move against calibrated weight springs which connect them to the breaker cam assembly. The breaker cam assembly fits on the top of the shaft (slip fit) and rotates with the shaft, being driven by the weight springs actuated by the advance weights.

Outward movement of the weights advances the cam assembly in relation to the shaft as engine speed is increased, providing an earlier spark.

It is possible to improve fuel economy on engines operating under part-throttle conditions by supplying additional spark advance. Vacuum advance mechanisms are provided on distributors for this purpose. The mechanism used rotates the breaker plate in order to time the spark earlier when the engine is operating at part throttle.

### Centrifugal Advance

The centrifugal advance mechanism times the high voltage surge produced by the ignition coil so that it is delivered to the engine at the correct instant, as determined by engine speed.

When the engine is idling, the spark is timed to occur in the cylinder just before the piston reaches top dead center. At higher engine speeds, however, there is a shorter interval of time available for the fuel-air mixture to ignite, burn, and give up its power to the piston. Consequently, in order to obtain the maximum amount of power from the mixture, it is necessary at higher engine speeds for the ignition system to deliver the high voltage surge to the cylinder earlier in the cycle.

To illustrate this principle, assume that the burning time of a given gas mixture in an automotive engine is .003 of a second. To obtain full power from combustion, maximum pressure must be reached while the piston is between 10 degrees and 20 degrees past top dead center. At 1,000 engine rpm, the crankshaft travels through 18 degrees in .003 of a second, at 2,000 rpm, the crankshaft travels through 36 degrees. Since maximum pressure point is fixed, it is easy to see why the spark must be delivered into the cylinder earlier in the cycle in order to deliver full power, as engine speed increases.

As previously mentioned, the timing of the spark to engine speed is accomplished by the centrifugal advance mechanism, which is assembled on the distributor shaft. The mechanism, consists primarily of

two weights and a cam assembly. The weights throw out against spring tension as engine speed increases. This motion of the weights turns the cam assembly so that the breaker cam is rotated in the direction of shaft rotation to advanced position with respect to the distributor drive shaft. The higher the engine speed, the more the weights throw out and the further the breaker cam is advanced.

The centrifugal advance required varies considerably between various engine models. In order to determine the advance for a given engine, the engine is operated on a dynamometer at various speeds with a wide-open throttle. Spark advance is varied at each speed until the range of advance that gives maximum power is found. The cam assembly, weights and springs are then selected to give this advance. Timing, consequently, varies from no advance at idle to full advance at high engine speed where the weights reach the outer limits of their travel.

### Vacuum Advance

Under part-throttle operation a high vacuum develops in the intake manifold and a smaller amount of air and gasoline enters the cylinder. Under these conditions, additional spark advance (over and above advance provided by the centrifugal advance mechanism) will increase fuel economy. In order to realize maximum power, ignition must take place still earlier in the cycle.

To provide a spark advance based on intake manifold vacuum conditions, many distributors are equipped with a vacuum advance mechanism. The mechanism has a spring-loaded diaphragm connected by linkage to the distributor. The spring-loaded side of the diaphragm is air-tight, and is connected in many cases by a vacuum passage to an opening in the carburetor. This opening is on the atmospheric side of the throttle when the throttle is in the idling position. In this position, there is no vacuum in the passage.

When the throttle is partly opened, it swings past the opening of the vacuum passage. Intake manifold vacuum then can draw air from the air-tight chamber in the vacuum advance mechanism and this causes the diaphragm to be moved against the spring. This motion is transmitted by linkage to the distributor breaker assembly rotation is governed by the amount of vacuum in the intake manifold up to the limit imposed by the design of the vacuum advance mechanism.

When the distributor breaker plate assembly is rotated, the contact points are carried around the breaker cam to an advanced position, so that the breaker cam contacts the rubbing block and closes and opens the points earlier in the cycle. This pro-

vides a spark advance based on the amount of vacuum in the intake manifold. Thus, for varying compressions in the cylinder the spark advance will vary, permitting greater economy of engine operation. It should be recognized that the additional advance provided by vacuum control is effective in providing additional economy only on PART-THROTTLE operation.

At any particular engine speed there will be a certain definite advance resulting from operation of the centrifugal advance mechanism, plus a possible additional advance resulting from operation of the vacuum advance mechanism. For example, an initial timing advance of 5 degrees, plus a centrifugal advance of 10 degrees, makes a total of 15 degrees advance at 40 miles an hour. If the throttle is only partly opened, an additional vacuum advance of up to 15 degrees more may be obtained, making a total of 30 degrees. When the throttle is wide open there is no appreciable vacuum in the intake manifold, so this additional advance will not be obtained. All advance then is based on engine speed alone and is supplied by the centrifugal advance mechanism.

The vacuum advance mechanism is an economy device which will increase fuel economy when properly used. The driver who drives with wide-open throttle whether in low or high gear will not obtain this additional advance with its resulting increased fuel economy.

### Cam Angle

The cam angle, often referred to as contact angle or dwell angle, is the number of degrees of cam rotation during which the distributor contact points remain closed. It is during this period of cam rotation that the current in the primary winding increases. Although the cam angle may not change, the length of time the contacts remain closed becomes less and less as the engine speed increases. At higher engine speeds, the ignition coil primary current does not reach its maximum value in the short length of time the contacts are closed. In order to store the maximum amount of energy obtainable on the coil, and consequently obtain sufficient energy to fire the plug, it is necessary to design a breaker lever assembly that will operate properly at high speeds. The distributor is equipped with a special-high rate-of-break cam and a special high speed breaker lever which is capable of following the cam shape at high speeds without bouncing. The high rate-of-break cam separates the contact points faster for each degree of rotation and permits closing earlier, thus increasing cam angle. With the special cam and breaker lever combination, it is possible to obtain the maximum cam angle and consequently optimum ignition performance at high speeds.

The point opening is the maximum distance that occurs between the separated contacts as the cam rotates. If the cam angle is properly set, the point opening most likely will also be according to specifications. In some cases, it may be necessary to measure point opening in addition to cam angle to insure that the contacts are properly set. A feeler gauge on new contacts, or a dial indicator on used contacts may be used to measure point opening.

### Ignition Condenser (Capacitor)

The capacitor consists of a roll of two layers of thin metal foil separated by a thin sheet or sheets of insulating material. This assembly is sealed in a metal can with a flat spring washer providing a tight seal.

The high voltage induced in the coil primary causes the capacitor plates to charge when the contacts first separate; the capacitor acts initially like a short circuit and current flows into the capacitor to minimize arcing at the contacts.

### Ignition Coil

An ignition coil is a pulse transformer that steps up the low voltage from the battery or generator to a voltage high enough to ionize the spark plug gap and ignite the air-fuel mixture in the cylinder. A typical coil is made up of a primary winding, consisting of a few hundred turns of relatively large wire, and a secondary winding, consisting of many thousand turns of a very small wire. These windings are assembled over a soft iron core and are enclosed by a soft iron shell. This assembly is inserted into a one-piece, steel or diecast aluminum coil case, which is filled with oil and hermetically sealed by a coil cap made of molded insulating material. The cap contains the primary and secondary high voltage terminals.

The ignition coils are hermetically sealed to prevent the entrance of moisture, which would cause coil failure. During manufacture, the coil case also is filled with oil at a high temperature. As the oil temperature decreases to more nearly match the temperature of the surrounding air, the oil contracts to occupy less volume thus allowing room for expansion when the coil heats up during normal operation. The oil acts as an insulator to prevent high voltage arc-over within the coil.

In the design of an ignition system, sufficient primary circuit resistance must be present to protect the distribution contacts from excessive arcing and burning. In some ignition systems, part of this resistance may take the form of a separate resistor or a

calibrated resistance wire connected between the ignition switch and the coil primary terminal. Since the value of this resistor along with the resistances of the other components in the entire primary circuit affects the coil performance at higher engine speeds.

During cranking, the external resistance on most applications is by-passed to provide full battery voltage to the coil for improved performance and easier starting. The by-pass wire may be connected to an "R" terminal on the cranking motor solenoid which contacts the contact disk during cranking, or to a separate terminal on the ignition switch, as shown in the previous section. The higher currents during cranking are not sufficient to cause distributor contact deterioration because of the short periods of time in the life of contacts spent during cranking. Also, the lowered battery voltage during cranking causes a lower primary current, so the resistor by-pass feature is an offsetting factor. By-passing the resistor with the engine operating will cause very rapid failure of the distributor contacts.

## SPARK PLUGS

The spark plug consists of a metal shell in which is fastened a porcelain insulator and an electrode extending through the center of the insulator. The metal shell has a short electrode attached to one side and bent in toward the center electrode. There are threads on the metal shell that allow it to be screwed into a tapped hole in the cylinder head. The two electrodes are of special heavy wire, and there is a specified gap between them. The electric spark jumps this gap to ignite the air-fuel mixture in the combustion chamber, passing from the center, or insulated, electrode. The seals between the metal base, porcelain, and center electrode as well as the porcelain itself, must be able to withstand the high pressure and temperature created in the combustion chamber during the power stroke.

Some spark plugs have been supplied with a built-in resistor which forms part of the center electrode. The purpose of this resistor is to reduce radio and television interference from the ignition system as well as to reduce spark-plug-electrode erosion caused by excessively long sparking. We have been talking of the high-voltage surge from the ignition-coil secondary as though it were a single powerful surge that almost instantly caused the spark to jump across the spark plug gap. Actually, the action is more complex than that. There may be a whole series of preliminary surges before a full-fledged spark forms. At the end of the sparking cycle the spark may be quenched and may reform several times. All this takes place in only a few ten-thousandths of a second. The effect is that the ignition wiring acts like

a radio transmitting antenna; the surges of high voltage send out impulses that causes radio and television interference. However, the resistors in the spark plugs tend to concentrate the surges in each sparking cycle, reduce their number, and thus reduce the interference and also the erosive effect on the plug electrodes.

### Heat Range System

The "heat range" of a spark plug is determined primarily by the length of the lower insulator. The longer this is, the hotter the plug will operate; the shorter it is, the cooler the plug will operate.

Spark plugs, to give good performance in a particular engine, must operate within a certain temperature range (neither too hot or too cool). If the spark plug remains too cool: oil, soot, and carbon compounds will deposit on the insulator causing fouling and missing. If the plug runs too hot, electrodes will wear rapidly, and under extreme conditions, premature ignition (pre-ignition) of the fuel mixture may result.

Frequently, the wrong type of spark plugs, one with an improper heat range for the engine, may have been installed when replacing spark plugs originally fitted by the engine manufacturer and such misapplication may lead to poor performance. The heat range system makes it possible to select the type of spark plug that will operate within the correct temperature range for each specific engine.

Where abnormal operating conditions cause chronic carbon or oil fouling of the plugs, the use of a type one number higher (a "hotter" type) than recommended will generally remedy the trouble; and by the same formula, where chronic pre-ignition or rapid electrode wear is experienced, a type with one number lower (a "cooler" type) will generally be found satisfactory.

The last digit of the type number indicates the heat range position of the plug in the heat range system. Read the numbers as you would a thermometer—the higher the last digit, the "hotter" the spark plug will operate in the engine; the lower the last digit, the "cooler" the spark plug will operate.

### Spark Plug Reach and Threads

Spark plugs are manufactured in a number of thread sizes and "reaches." Reach is the distance from the gasket seat to the end of the shell. Spark Plugs have a type number on the insulator which designates plug thread size as well as the relative position in the heat range system as previously explained.

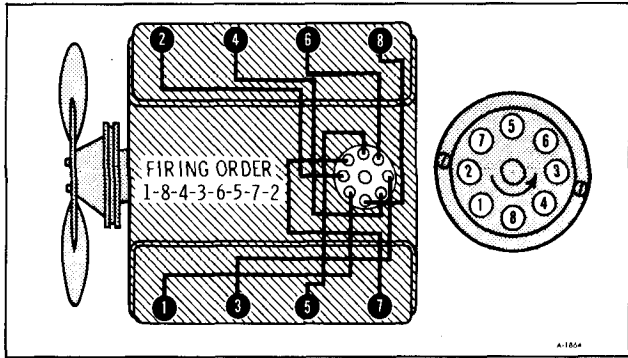

Figure 25—Secondary Wiring

## SECONDARY IGNITION CABLES (FIGURE 25)

The secondary wiring consists of the high tension cables connected between the distributor cap, the spark plugs, and the high tension terminal of the ignition coil. These cables carry the high voltage surges to the spark plugs and are heavily insulated to contain the high voltages. The cables are neoprene jacketed and have a multiple cloth thread core impregnated with a graphite solution to give the correct conductivity and proper resistance for suppression of radio and television interference.

## IGNITION SWITCH

The electrical switching portion of the assembly is separate from the key and lock cylinder. However, both are synchronized and work in conjunction with each other through the action of the actuator rod assembly. For a complete explanation of the key and lock cylinder, and the actuator rod assembly, refer to the Steering section of this manual.

The ignition switch is key operated through the actuator rod assembly to close the ignition primary circuit and to energize the starting motor solenoid for cranking. The ignition switch has five positions: OFF, LOCK, ACCESSORY, RUN and START. OFF is the center position of the key-lock cylinder, and LOCK is the next position to the left. ACCESSORY is located one more detent to the left of LOCK. Turning the key to the right of the OFF position until spring pressure is felt will put the ignition switch in the RUN position, and when turned fully to the right against spring pressure, the switch will be in the START position.

In the RUN position, the ignition primary circuit is activated through a resistance wire. The ignition resistor wire is used in the ignition running circuit to

reduce the voltage to the ignition coil. The resistor wire is bypassed when the engine is being started. The purpose of this is to compensate for the drop in voltage which occurs as the result of the heavy drain on the battery during starting, and to provide a hotter spark for starting.

All ignition switches have five terminals which are connected in different combinations for each of the three operating positions. A brass plate, inside the switch, has three contacts which connect these terminals, shows the positions of the contacts in all positions as viewed from the key side of the switch. There is also a ground pin in the switch which contacts the "ground" terminal when the ignition switch is in the START position. This pin contacts the IGN. terminal when in the OFF position.

### Ignition Start and Run Circuit

The ignition switch is fed from a junction at the horn relay to the BAT. terminal of the switch. When the ignition switch is in the OFF position, no current flows through the switch. When the ignition switch is turned to the ACC. position, the BAT. terminal is connected to the ACC. terminal. This permits operation of accessories when the engine is not running.

When the ignition switch is turned to the START position, the BAT. terminal is connected to the SOL. and IGN. terminals. When the clutch or automatic transmission neutral start switches are closed, current flows to the starter solenoid. This energizes the solenoid windings. The solenoid has two sets of windings: a "pull-in" winding and a "hold-in" winding. Both windings are used to create the magnetic field to actuate the solenoid plunger and move the starter pinion into engagement with the flywheel. As the solenoid plunger reaches the end of its travel, it closes a switch which connects battery voltage to the starter motor. With battery voltage applied to both terminals of the "pull-in" windings, the "pull-in" winding is no longer energized, so that only the "hold-in" winding keeps the starter solenoid engaged.

During cranking, current is directed from the battery through the brass disc in the starter solenoid housing to the "B" terminal on the solenoid and then to the ignition coil, bypassing the ignition resistor wire.

**NOTE:** The instrument panel warning lights are fed from the ignition terminal of the ignition switch and have battery voltage applied to them when the ignition switch is in the START and RUN position. These circuits are explained in Chassis Electrical, Section 12.

When the ignition switch is released from the START to the RUN position, the IGN. terminal is still connected to the BAT. terminal, but the solenoid is no longer energized and so the feed for the coil from the IGN. terminal on the ignition switch, through the ignition resistor wire and to the coil, dropping the battery voltage at the coil to approximately nine volts. With the ignition switch in the RUN position, the BAT. terminal is connected to the IGN. terminal and the ACC. terminal. This permits operation of all accessories and the ignition system.

## TROUBLE DIAGNOSIS

### IGNITION SYSTEM

#### A. Engine Will Not Start But Cranks O.K.

1. Disconnect a spark plug wire and hold 1/4" away from the engine block, then crank engine.

a. If strong spark is seen, check timing. Adjust as necessary. If timing is correct, trouble is not in ignition system.

b. If no spark or an intermittent spark is seen, reconnect plug wire and proceed to step 2.

2. Disconnect distributor cap-to-coil lead from coil and place screwdriver blade across coil tower to engine block and crank engine.

a. If strong spark is seen between coil tower and metal bar, check distributor cap and rotor for cracks or carbon tracking. Check lead between distributor and coil for broken or burned terminals or cracks in insulation. Replace defective parts.

b. If no spark or intermittent spark is seen, proceed to step 3.

3. Connect jumper wire from battery plus (+) terminal to coil plus (+) terminal. Place a screwdriver blade across coil tower to engine block and crank engine.

a. If strong spark is seen, remove jumper wire and check wiring connections and switches between battery plus (+) terminal and coil (+) terminal. Opens, high resistance or intermittent contact will require repair or replacement.

b. If no spark or intermittent spark is seen, remove jumper wire and proceed to step 4.

4. Disconnect distributor lead from coil minus (-) terminal and connect test light from coil minus

(-) terminal to engine block. Turn ignition switch to crank position.

a. If lamp does not light, replace coil.

b. If lamp lights proceed to step 5.

5. Connect test light from battery plus (+) terminal to distributor lead which is still detached from the coil. If necessary, rotate distributor until points close.

a. If lamp lights, check condenser and points. Replace defective parts.

b. If lamp does not light, proceed to step 6.

6. Connect test lamp from battery plus (+) terminal to connection of distributor lead and contact points. Make sure points are closed.

a. If lamp lights, replace distributor lead to coil.

b. If lamp does not light, proceed to step 7.

7. Connect test lamp from battery plus (+) terminal to screw holding points in place.

a. If lamp lights, replace points and check capacitor.

b. If lamp does not light, breaker plate or distributor is not grounded. Check plate-to-distributor ground wire or distributor-to-engine block connector.

#### B. Engine Starts But Will Not Continue to Run

1. Connect jumper wire from battery plus (+) terminal to ignition coil plus (+) terminal and start engine.

a. If engine does not continue to run, problem is not ignition.

b. If engine runs, proceed to step 2.

2. Remove jumper and disconnect leads from battery plus (+) terminal and coil (+) terminal. Connect ohmmeter and measure resistance between the ends of the leads just detached. Ignition switch should be in the run position.

a. If resistance exceeds 2.5 ohms, check wires and connections for loose or intermittent contact. Check by-pass resistor and ignition switch for opens.

b. If resistance is 1.0 to 2.5 ohms, check the output of the ignition coil.

c. If resistance is less than 1.0 ohm, replace shorted by-pass resistor and replace contact points.

### **C. Engine Runs Rough, Poor Power or Gas Mileage**

1. Check all tune-up specifications (timing, dwell, carburetion, fouled plugs, etc.) If settings are improper, correct as required.

2. If settings are O.K. check both centrifugal and vacuum advance of distributor and correct with replacement parts, if necessary.

3. If distributor advance mechanisms are within specifications, check coil available voltage and plug required voltage.

a. High requirements or low availability of voltage will require a replacement of parts.

b. If coil and plugs are O.K., the problem is not in the ignition system.

1. Apply test points to both primary terminals of coil. If test lamp does not light, the primary circuit is open.

2. Apply one test point to the high tension terminal, and the other test point to one of the primary terminals. If secondary circuit is not open, the lamp will not light but tiny sparks will appear at test points when they are rubbed over terminals. If secondary circuit is open, no sparks will occur.

3. Apply one test point to a clean spot on the metal coil case and touch the other point to the primary and high tension terminals. If the lamp lights, or tiny sparks appear at the points of contact, the coil windings are grounded.

4. A coil with open or grounded windings must be replaced since internal repairs cannot be made. It is unnecessary to test such a coil with instruments. If windings are not open or grounded, a test for short circuits and other internal defects should be made with a reliable coil test instrument.

## **IGNITION COIL TEST**

### **A. Weak Coils**

Most ignition coils that are replaced are classified as weak. Many coils rejected as weak actually test up to specifications and give normal performance. A coil that actually is weak will first effect engine performance when the ignition reserve is at a minimum. This may be in starting, low speed acceleration or top speed. Eventually the engine will fail to start.

High resistance connections in either the primary or secondary circuit wiring will react the same as a weak coil. Wide spark plug gaps, which require higher voltage than the coil can produce, put the coil under suspicion. High compression and lean carburetor increase the voltage requirements and lead to many needless coil changes. Leakage of high tension current through moisture on an unprotected coil terminal may produce carbon tracks which weaken the coil output voltage. For this reason the nipple on coil high tension terminal must be properly installed and in good condition.

When an ignition coil is suspected of being defective it should be tested as described below before being replaced.

### **B. Testing Coil for Open and Grounded Circuits**

Before using a coil test instrument, the coil should be tested for open and grounded circuits, using a 110-volt test lamp and test points.

### **C. Coil Test Instruments**

Two general type of instruments are used in testing ignition coils. One type makes use of an open or protected spark gap, while the other reports the condition of the coil on a meter.

The spark gap type of tester should always be used comparatively, that is, the questionable coil should be compared with a coil of same model that is known to be good. Both coils must be at the same temperature and identical test leads must be used.

Certain variables caused by altitude, atmosphere or spark gap electrode conditions are usually present in the spark gap type of test.

The meter type testers are usually designed to permit testing the coil without making any connection to the secondary terminal. This eliminates the variables usually present in the spark type of test and avoids the necessity for comparison with a good coil.

Some different makes and models of coil testers differ in their methods of use, as well as in the markings on meters, the instructions of the manufacturer must be carefully followed when using any coil tester. The instrument must be frequently checked to make certain that it is accurately calibrated.

Regardless of instrument or method used, the coil must be tested at normal operating temperature because internal defects often fail to show up on a cold test.

## DISTRIBUTOR CONDENSER TEST

When a condenser is suspected of being faulty it should be tested with a reliable condenser tester to determine whether it is actually the cause of ignition trouble. The condenser should be tested for (a) high series resistance (b) insufficient or excessive capacity (c) low insulation resistance.

A special condenser tester is required to make these tests. When using a condenser tester the instructions of the manufacturer must be carefully followed.

**NOTE:** The condenser must be at normal operating temperature when it is being tested.

### A. High Series Resistance

High series resistance in the condenser causes the condenser to be slow in taking the charge and, consequently, a higher than normal voltage is developed across the contact points when they first start to open. The higher voltage causes more disturbance at the contact points, which in turn causes more rapid wear and more tendency toward oxidized surfaces. The condition can become severe enough to cause complete failure of the ignition system. It would first show up during starting and low speed operation.

High series resistance may be caused by internal resistance in condenser or by resistance in the connections. Any defect caused by internal resistance should show up at low mileage since this does not change very much with time or use. The damaging changes are in the connections, in which looseness, corrosion, or broken strands may develop.

New condensers may have a series resistance as low as .05 ohm. Some condenser testers are set to reject condensers which have a resistance of .3 ohm; however, test show that the resistance can go to .5 ohm before ignition performance is affected.

### B. Insufficient or Excessive Capacity

The condenser specified for use in the ignition system has a capacity of .18 to .23 microfarads.

If a condenser is used which does not have the specified capacity of .18 to .23 microfarads, excessive pitting of one contact point and a corresponding buildup of metal on the other contact point will result. A condenser having insufficient capacity will cause build-up of metal on the breaker arm (positive) point. A condenser having excessive capacity will cause build-up of metal on the contact support (negative) point.

In exceptional cases, pitting and metal buildup on contact points may be experienced even when condenser capacity is within the specified limits. In such cases the life of contact points will be improved by installing a condenser of high-limit capacity if metal build-up is on breaker arm point, or a condenser of low-limit capacity if metal build-up is on contact support point. There is usually sufficient variation in the capacities of stock condensers to permit selection of a high or low limit condenser by testing the available stock.

### C. Low Insulation Resistance

A weak or leaking condenser is usually one that has absorbed water so that the insulation resistance of the winding is lowered to the extent that the condenser will not hold a charge satisfactorily. A condenser with low insulation resistance will drain sufficient energy from the ignition system to lower the secondary voltage seriously. The condenser specified for use in the ignition system is sealed to prevent absorption of water, and no other type should be used.

A leaky condenser usually does not affect engine performance except when hot. It is unlikely that a condenser with low insulation resistance would cause missing at low or medium speeds under conditions where the condenser does not get hot. A condenser that has low enough resistance to affect engine performance when cold would probably be indicated as broken down on most condenser testers.

Condenser testers equipped to check condensers for low insulation resistance usually give a reading megohms, a megohm being one million ohms. The scale is marked to indicate whether the condenser is good or bad.

When testing a condenser for low insulation resistance the lead should always be disconnected from the distributor. Since the distributor terminals and the connected circuit have much lower insulation resistance than the condenser, failure to disconnect the condenser lead will give a reading much too low.

## IGNITION SYSTEM RESISTANCE TEST

Check for proper functioning of the resistance in the primary ignition circuit by turning on the ignition. With the engine not running, a voltmeter connected from the battery side of the coil to ground should read approximately 5 to 5.5 volts. If the reading is a full 12 volts, the ignition points may be open; "bump" the starter a few times until the engine comes to rest with the ignition points closed and

again check for a 5.5 volt reading. A reading of 12 volts or over for all engine positions would indicate that the shorting switch is making contact all the time; this condition must be corrected immediately or ignition point life will be very short.

Check for proper closing of the shorting switch and also for proper functioning of the complete starting circuit by grounding the secondary coil wire so the engine won't start. With the engine cranking, a voltmeter connected from the battery side of the coil to ground should read at least 9 volts. A reading of under 5 volts would indicate that the shorting switch is not closing; this condition would result in hard cold starting.

Briefly, the advantages of our resistance with shorting switch system are: it sends full battery voltage to the coil for good cold weather starting, and it cuts down the voltage to the coil with the engine running for long ignition point life.

**NOTE:** Discourage any attempts to measure voltage at the coil with the engine running; because of variations in current flow at high speeds and in regulated voltage, this check would be meaningless. Voltage readings on a perfectly-functioning ignition system may go over 11 volts.

## SPARK PLUGS

Under normal operating conditions, spark plugs wear out due to the destructive action, under intense heat, of sulphur and lead compounds in the fuel and the bombardment of the electric spark on the electrodes.

The same type of spark plug used in two different engines of the same make and model may frequently show wide variation in appearance. The cause of such differences lies in the condition of the engine, its piston rings, carburetor setting, kind of fuel used, and under what conditions the engine is operated, namely, sustained high speeds or heavy loads; or continual low speed, stop-and-go driving or light loads.

Spark Plugs are frequently blamed for faulty engine operation which they do not cause. Replacement of old spark plugs by new may temporarily improve poor engine performance because of the lessened demand new plugs make on the ignition system. This cannot permanently cure poor engine performance caused by worn rings or cylinders, weak coil, worn contact points, faulty carburetion or other engine ills.

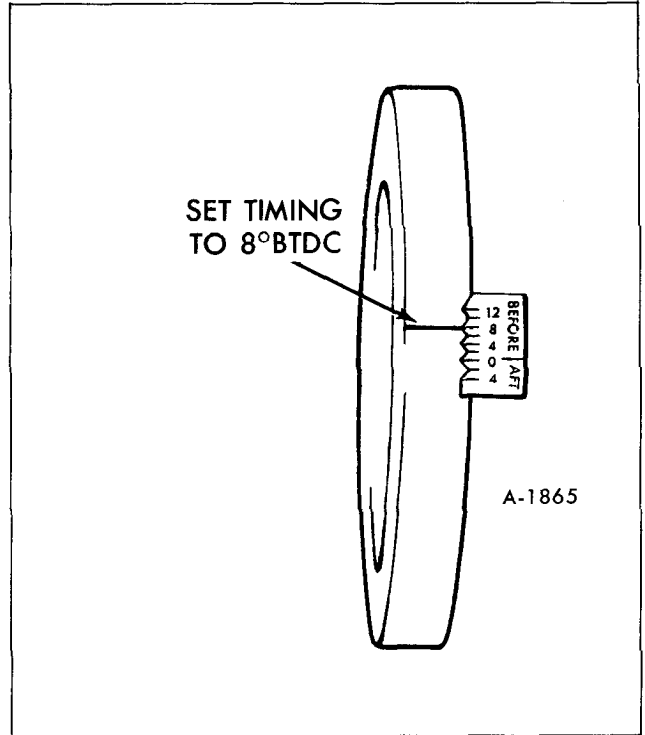

Figure 26—Engine Ignition Timing

## IGNITION TIMING

The ignition timing marks are located on the engine front cover. A saw slot on the balancer indicates engine top dead center. (figure 26)

To adjust ignition timing, proceed as follows:

1. Remove air cleaner and plug manifold vacuum fitting.
2. Disconnect vacuum hoses at carburetor and plug fittings.
3. Connect tachometer and adjust engine speed to 1100 rpm with transmission in neutral.
4. With the use of a timing light, set timing to 8° BTDC by loosening the distributor clamp bolt and rotating the distributor until the specification is obtained.

**NOTE:** The indicator has four “V” slots, each representing 4°.

5. Tighten the distributor clamp bolt and recheck timing to make sure distributor was not moved during tightening of bolt.

**NOTE:** If a tuned engine detonates with this setting, the cause is low octane fuel or excessive



carbon build-up in the combustion chamber. If these factors are not corrected, the timing should be retarded 2 degrees from the specified setting.

6. Remove plug from fittings and connect hoses to carburetor. Remove tape from manifold fitting and connect vacuum hose, install air cleaner.

## DISTRIBUTOR (FIGURE 27)

### DESCRIPTION

The distributor cap has a window for adjusting point opening (dwell angle) while the cap is mounted and the engine is running. The contact point set is replaced as one complete assembly. The service replacement contact set has the **BREAKER LEVER SPRING TENSION AND POINT ALIGNMENT** pre-adjusted. Only the **POINT OPENING** requires adjusting after replacement.

Under part throttle operation when the transmission is in high gear, intake manifold vacuum actuates

the vacuum control diaphragm, thus advancing the spark and increasing fuel economy. During fast acceleration or when the engine is pulling heavily, vacuum is not sufficient to actuate the diaphragm; therefore, the movable breaker plate is held so that the ignition timing is retarded.

The centrifugal advance mechanism consists of a cam actuated by two centrifugal weights controlled by springs. As the speed of the distributor shaft increases with engine speed, centrifugal advance weights move outward which advances the cam, causing the contact points to open earlier, thus advancing the spark.

### CONTACT POINT REMOVAL

1. Remove distributor cap and rotor. (figure 28)

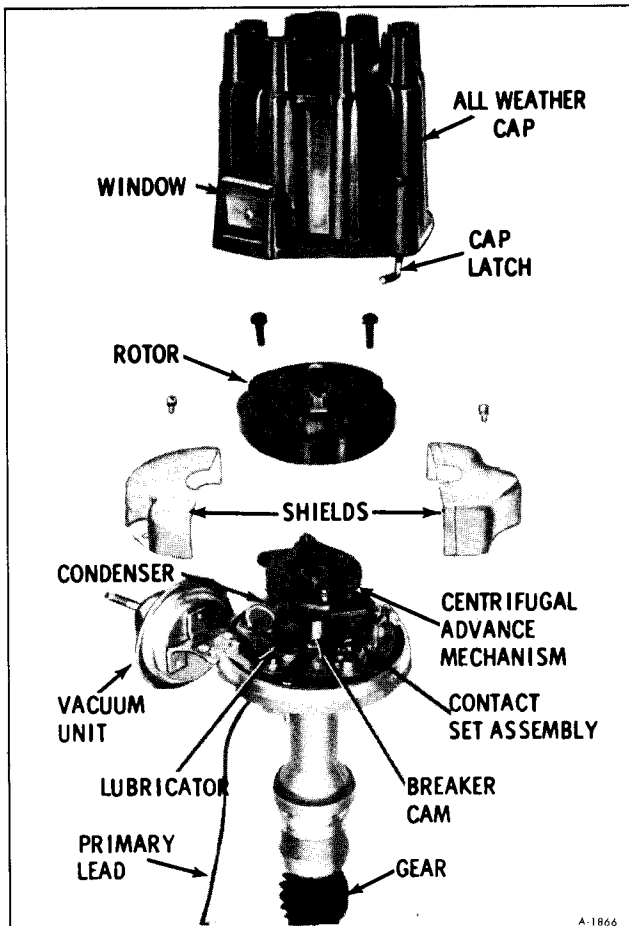

Figure 27—Distributor Components

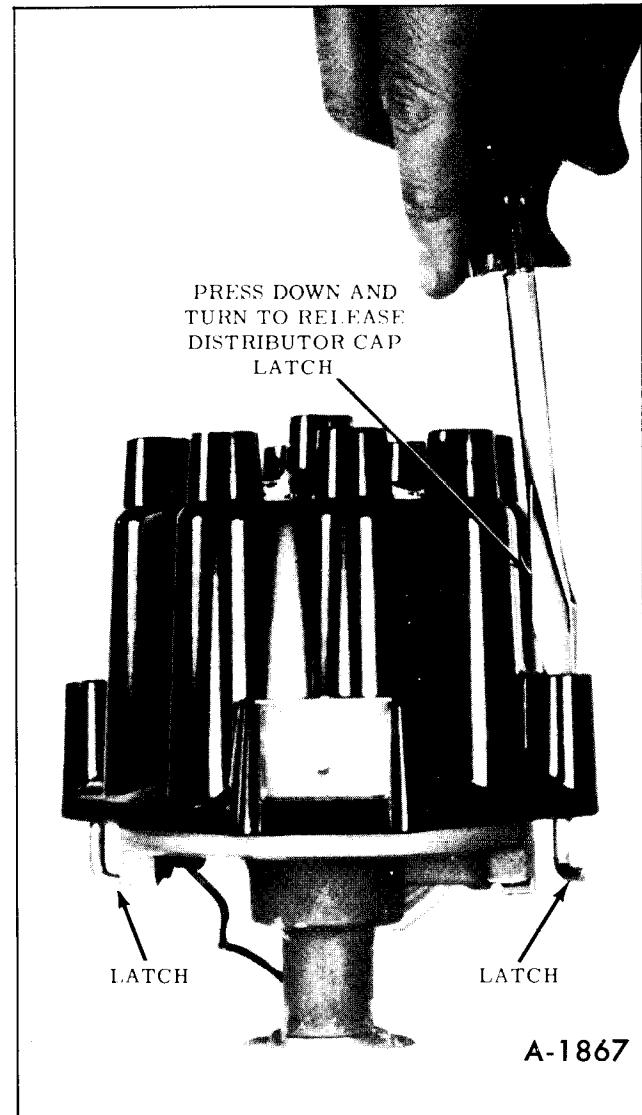

Figure 28—Removing Distributor Cap

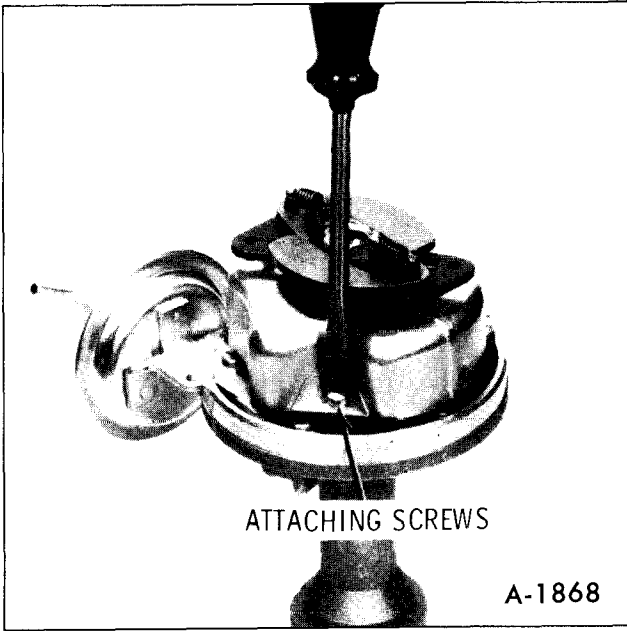

Figure 29—Removing Point Shield

2. Remove two piece metal shield attaching screws and shields. Figure 29.

3. Lift the two wiring terminals out of the snap-lock retainer, Figure 30, and remove the two screws and contact points.

### CONTACT POINT INSTALLATION

**NOTE:** The two-piece shield suppresses radio interference and must be installed and screws tightened securely. Snap-lock (push in) terminal contact points have sufficient clearance between

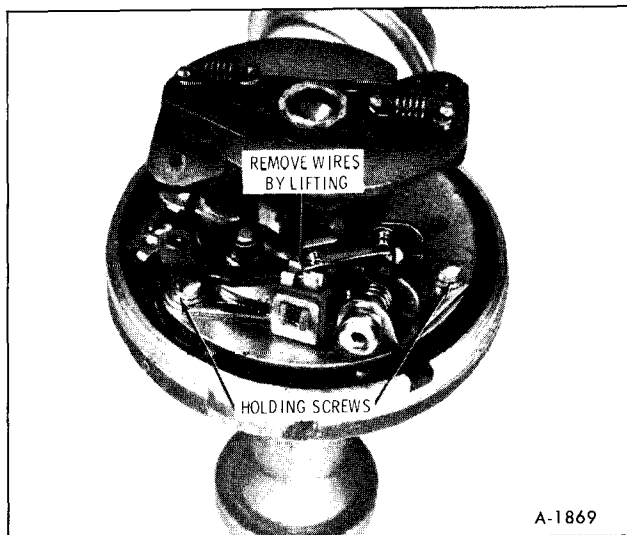

Figure 30—Removing Contact Points

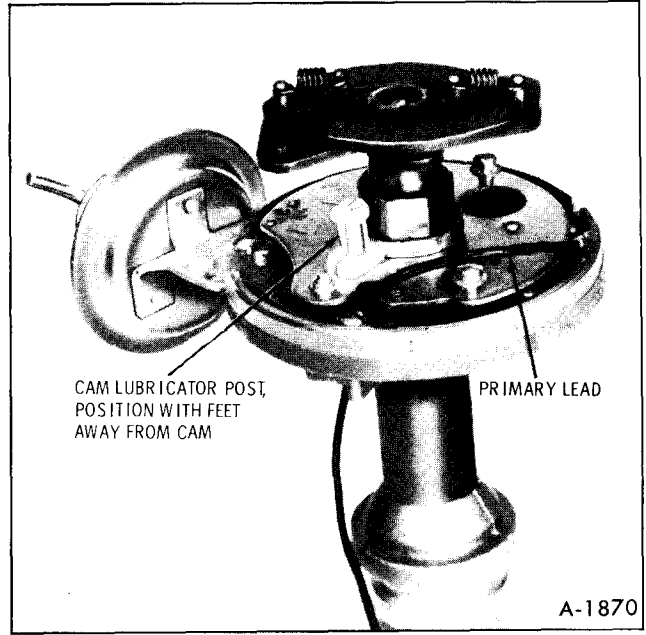

Figure 31—Cam Lubrication

the shield and wire terminals to prevent accidental short circuiting. Screw terminal contact point sets may not have sufficient clearance. Wire terminals must be firmly pushed in and bent slightly toward cam to prevent them from touching the shield.

1. Install contact points on breaker plate.

2. Install primary and condenser wire terminals in snap-lock terminals. Seat them firmly and bend them slightly toward cam. Position wires to prevent interference with weights, rotor or distributor cap.

3. The cam lubricator is mounted on breaker plate with feet away from cam. Figure 31. Apply a



Figure 32—Installing Point Shield



Figure 33—Installing Rotor

thin film of lubricant 1948792 or equivalent to cam, not the wick.

4. Place one-half of shield over contact points, Figure 32, align screw hole, install and firmly tighten screw. Make sure wire terminals are not touching shield.
5. Install other half of shield, align screw hole, install and firmly tighten screw.
6. Install rotor, Figure 33.
7. Install distributor cap.

## ADJUSTING DWELL ANGLE

1. Remove the distributor cap, rotor, and shields. Inspect contact points; clean if necessary. Check cam lubricator for sufficient lubricant, if necessary apply a thin film of lubricant No. 1948792 or equivalent to the breaker cam. Install shields, rotor and cap.
2. Connect a dwell meter to the distributor primary distributor negative lead terminal on the coil and ground.
3. Raise window on side of distributor cap.
4. With the engine running at idle speed, insert 1/8" Allen wrench into the head of the adjusting screw as shown in Figure 34 and adjust dwell angle to 30 degrees.

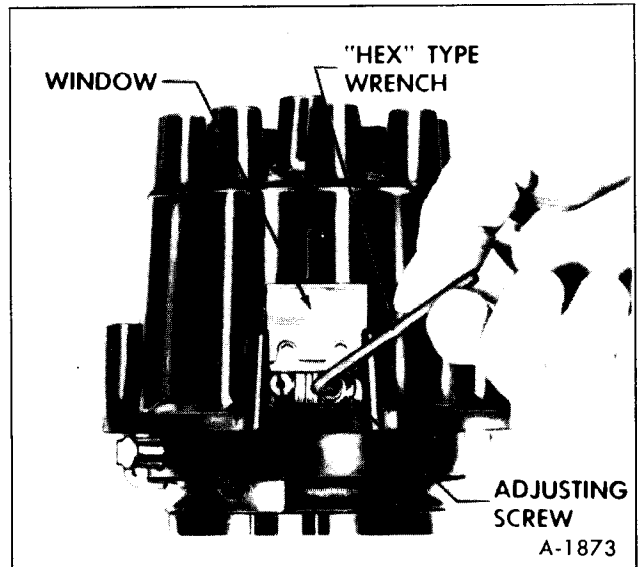

Figure 34—Adjusting Dwell Angle

**NOTE:** If the dwell angle reading is erratic, check the contact points and condenser.

The dwell angle variation should not exceed 3 degrees at engine speeds between idle and 1750 rpm. Excessive variation indicates distributor wear.

## MECHANICAL ADVANCE

The mechanical advance weights and springs are accessible by removing the rotor. The mechanical advance plate is assembled to the breaker cam. In order to remove the breaker cam and advance plate, follow the procedure for DISTRIBUTOR-DISASSEMBLY and ASSEMBLY.

## VACUUM ADVANCE UNIT

### REMOVAL

1. Remove the distributor cap, shield and the two vacuum advance attaching screws. (figure 35)
2. Turn the breaker plate clockwise and push the rod end of the vacuum advance down so that it will disengage and clear the breaker plate. Remove vacuum advance unit.

### Installation

1. Position the rubber sleeve over the rod end of the vacuum advance.

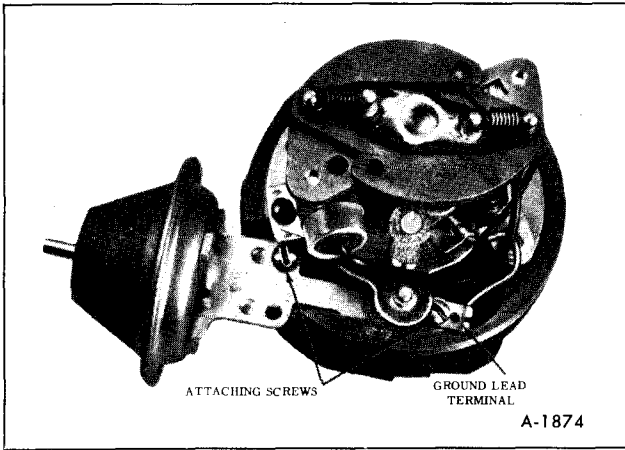

Figure 35-Vacuum Advance Unit

2. Insert the rod end of the unit between the housing and the breaker plate.

3. Turn the breaker plate clockwise so that the rod end can be inserted into the hole in the breaker plate.

4. Install the attaching screws with the ground lead terminal under the inner mounting screw. (figure 35) Install the shield and distributor cap.

## DISTRIBUTOR REMOVAL

1. Disconnect the distributor wire from coil.
2. Remove distributor cap as shown in Figure 28.

**NOTE:** If necessary to remove secondary wires from cap, note position on cap tower for lead to No. 1 cylinder. This will aid in installation of leads. (figure 25)

3. Remove vacuum hose line from vacuum advance unit.

4. Remove distributor clamp screw and hold-down clamp.

5. Note position of rotor, then pull distributor up until rotor just stops turning counterclockwise and again note position of rotor.

**NOTE:** To insure correct timing of the distributor, the distributor must be **INSTALLED** with the rotor correctly positioned as noted in Step 5.

If the engine has been turned after the distributor was removed, it will be necessary to install a jumper wire and crank engine until the timing mark on the harmonic balancer indexes with the 0 degree timing

mark on the engine front cover. If both valves of the No. 1 cylinder are closed, the piston will be on top dead center in either the firing or exhaust stroke. Install distributor so that the rotor is pointing to No. 1 spark plug terminal in the cap when the distributor is fully seated. Install clamp and bolt, start engine. If engine fails to start or runs uneven, distributor is 180 degrees out of time. Lift up distributor, turn rotor one half revolution and install distributor.

## DISTRIBUTOR DISASSEMBLY

1. Mark distributor shaft and gear so that they may be reassembled in the same position.

2. Drive out the roll pin. (figure 36)

3. Pull the distributor assembly from the gear and pull the distributor shaft and breaker cam from the housing.

4. Remove the retaining ring from the upper bushing and lift the breaker plate and felt wick from the bushing. (figure 37)

5. Remove the two retaining screws and the vacuum advance unit.

## CLEANING AND INSPECTION

1. Wash all parts in cleaning solvent except cap,

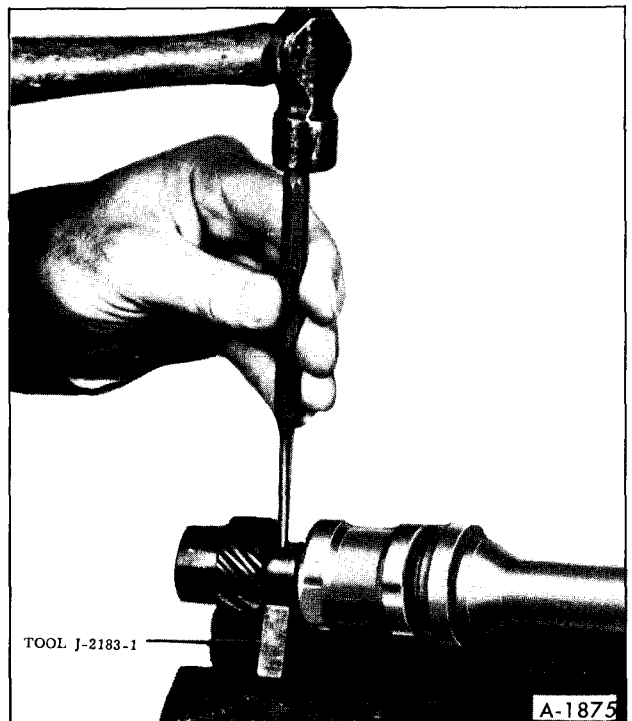

Figure 36-Removing Roll Pin

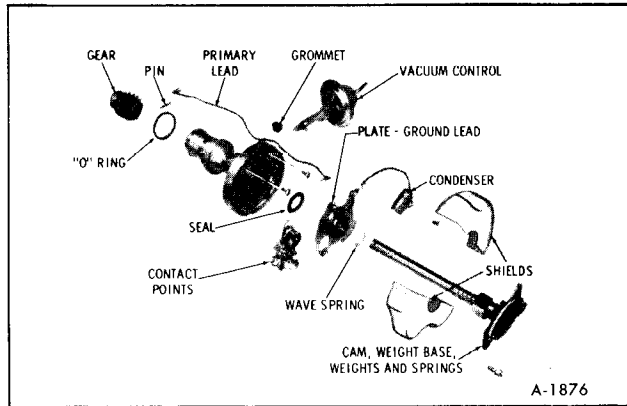

Figure 37—Distributor Disassembled

rotor, condenser, breaker plate assembly and vacuum control unit. Degreasing compounds may damage insulation of these parts or saturate the lubricating felt in the case of the breaker plate assembly.

2. Inspect the breaker plate assembly for damage or wear and replace if necessary.
3. Inspect the shaft for wear and check its fit in the bushings in the distributor body. If the shaft or bushings are worn, the parts should be replaced.
4. Mount the shaft in "V" block and check the shaft alignment with a dial gauge. The runout should not exceed .002".
5. Inspect the advance weights for wear or burrs and free fit on their pivot pins.
6. Inspect the cam for wear or roughness. Then check its fit on the end of the shaft. It should be absolutely free without any roughness.
7. Inspect the condition of the distributor points. Dirty points should be cleaned and badly pitted points should be replaced.
8. Test the condenser for series resistance, microfarad capacity (.18 to .23) and leakage or breakdown, following the instructions given by the manufacturer of the test equipment used.
9. Inspect the distributor cap and spark plug wires for damage and replace if necessary.

## DISTRIBUTOR ASSEMBLY

1. Install the vacuum advance with the ground lead terminal under the inner mounting screw. (figure 35)

2. Place the felt wick on the upper bushing then place the breaker plate over the upper bushing and vacuum advance link.

3. Install the retaining ring on the upper housing.

4. Slide the distributor shaft through housing bushings.

5. Push the driven gear onto the distributor shaft with the holes aligned.

6. Install the roll pin.

7. Check and adjust dwell angle, vacuum advance and the mechanical advance. Refer to SPECIFICATIONS (Distributor).

## ADJUSTING DISTRIBUTOR DWELL ANGLE

1. With distributor mounted in distributor testing machine, connect the dwell meter to the distributor primary lead.

2. Turn the adjusting screw to set the dwell angle at 30 degrees.

If a distributor tester is not available, the dwell angle may be adjusted as follows:

1. Mount distributor in a vise.

2. Connect a test lamp between the primary lead and ground.

3. Rotate the shaft until one of the breaker cam lobes is under the center of the rubbing block on the moveable point.

4. Turn the adjusting screw clockwise until the lamp lights, then turn the screw one-half turn in the opposite direction.

When distributor has been installed in vehicle, point opening must be reset by connecting a dwell meter to the primary distributor lead negative terminal on the coil and ground. The dwell angle must be set at 30 degrees with the engine running at idle speed.

## ROTOR

The rotor is retained by two screws and is provided with round and square lugs which engage with

the mechanical advance plate so that the rotor may be installed in only one position. (figure 33)

## **DISTRIBUTOR INSTALLATION**

### **Engine Not Disturbed**

1. Turn the rotor about 1/8 turn in a clockwise direction past the mark previously placed on the distributor housing to locate rotor.

2. Push the distributor down into position in the block with the housing in a normal "installed" position.

**NOTE:** It may be necessary to move rotor slightly to start gear into mesh with camshaft gear, but rotor should line up with the mark when distributor is down in place.

3. Tighten the distributor clamp bolt snugly and connect vacuum line. Connect primary wire to coil terminal and install spark plug and high tension wires if removed.

**NOTE:** It is important that the spark plug wires be installed in their proper location in the supports and also in the cap. (figure 25).

4. Time ignition as previously described.

### **Installation—Engine Disturbed**

1. Locate No. 1 piston in firing position by either of two methods described below.

a. Remove No. 1 spark plug and, with finger on plug hole, crank engine until compression is felt in the No. 1 cylinder. Continue cranking until timing mark on crankshaft pulley lines up with timing tab attached to engine front cover.

b. Remove rocker cover (left bank) and crank engine until No. 1 intake valve closes and continue to crank slowly about 1/3 turn until timing mark on pulley lines up with timing tab.

2. Position distributor to opening in block in normal installed attitude, noting position of vacuum control unit.

3. Position rotor to point toward front of engine (with distributor housing held in installed attitude), then turn rotor counter-clockwise approximately 1/8 turn more toward left cylinder bank and push distributor down to engine camshaft. It may be necessary to rotate rotor slightly until camshaft engagement is felt.

4. While pressing firmly down on distributor housing, kick starter over a few times to make sure oil pump shaft is engaged. Install hold-down clamp and bolt and snug up bolt.

5. Turn distributor body slightly until points just open and tighten distributor clamp bolt.

6. Place distributor cap in position and check to see that rotor lines up with terminal for No. 1 spark plug.

7. Install cap, check all high tension wire connections and connect spark plug wires if they have been removed.

8. Connect vacuum line to distributor and distributor primary wire to coil terminal.

9. Start engine and set timing.

## **COIL REPLACEMENT**

1. Disconnect battery ground cables.

2. Disconnect ignition switch and distributor leads from terminals on coil.

3. Pull high tension wire from center terminal of coil.

4. Remove the coil support mounting bolt or loosen friction clamp screw and remove coil.

5. Place new coil in position and install attaching bolt or tighten clamp screw.

6. Place high tension lead securely in center terminal of coil and connect ignition switch and distributor primary leads to terminals on coil.

7. Connect battery ground cables.

8. Start engine and check coil operation.

## **SPARK PLUGS**

1. Remove foreign material from around the spark plug holes and remove the spark plugs.

2. Clean exterior of plugs and inspect for cracked insulators, poor sealing gaskets or excessively burned electrodes.

3. Clean all serviceable plugs with an abrasive type cleaner. File center electrode flat. (figure 38) Do not file center electrode on new plugs.

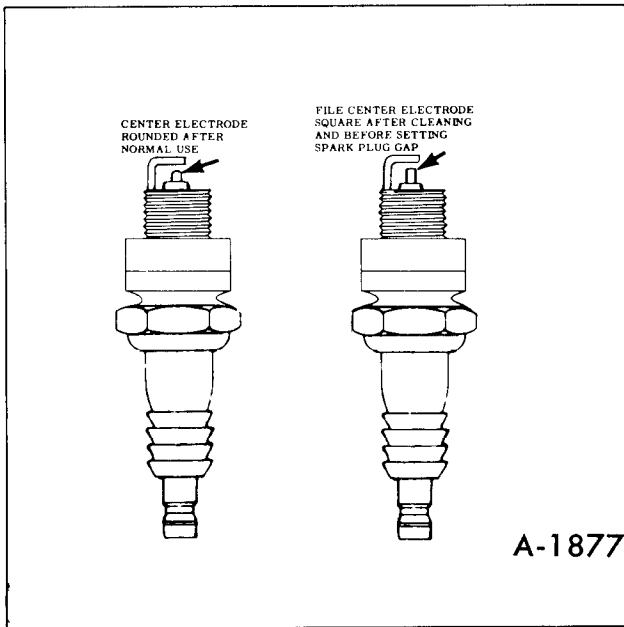

Figure 38—Spark Plug Electrodes

4. Adjust spark plug gap to .040" using a round feeler gauge.

5. Install plugs and torque to 35 ft. lbs.

**NOTE:** The spark plug gaskets are the captive type and are not to be replaced each time the plug is removed. The same gasket will usually seat even if the plug is removed up to four times.

## HIGH AND LOW TENSION WIRES

High tension wires include the wires connecting the distributor cap to the spark plugs, and the wire connecting the center electrode of the distributor cap to the center terminal of the ignition coil. Low tension wires are the small wires connected to the primary terminals on the coil, and to the primary terminal at the distributor.

High tension wires have a built-in resistance of approximately 4,000 ohms per foot except coil wire which is 8,000 ohms per foot.

At regular intervals wires should be inspected for damage. If insulation is cracked or swollen, wires should be replaced.

## IGNITION SWITCH

The electrical switching portion of the assembly is separate from the key and lock cylinder. However, both are synchronized and work in conjunction with each other through the action of the actuator rod assembly. For a complete explanation of the key and lock cylinder, and the actuator rod assembly, refer to the Steering section of this manual.

The ignition switch is key operated through the actuator rod assembly to close the ignition primary circuit and to energize the starting motor solenoid for cranking. The ignition switch has five positions: OFF, LOCK, ACCESSORY, RUN and START. OFF is the center position of the key-lock cylinder, and lock is the next position to the left. ACCESSORY is located one more detent to the left of LOCK. Turning the key to the right of the OFF position until spring pressure is felt will put the ignition in the RUN position, and when turned fully to the right against spring pressure, the switch will be in the START position.

In the RUN position, the ignition primary circuit is activated through a resistance wire. The ignition resistor wire is used in the ignition running circuit to reduce the voltage to the ignition coil. The resistor wire is bypassed when the engine is being started. The purpose of this is to compensate for the drop in voltage which occurs as the result of the heavy drain on the battery during starting, and to provide a hotter spark for starting.

## IGNITION SYSTEM SPECIFICATIONS

### DISTRIBUTOR

Make.....	Delco-Remy
Model No. ....	1112172
Rotation (Viewed at Rotor) .....	Counterclockwise
Point Opening (In.) .....	.016
Cam Angle (Degrees) .....	30
Centrifugal Advance	
Start Distributor (Degrees) .....	0-2
R.P.M. ....	575
Intermediate Distributor (Degrees).....	3.5-5.5
R.P.M. ....	1000
Maximum Advance Degrees .....	7-9
R.P.M. ....	1700
Firing Order.....	1-8-4-3-6-5-7-2
(*) Set with Vacuum in Retard Position.	

### IGNITION TIMING

Idle Speed (R.P.M.).....	1100
Distributor Setting .....	8° BTDC
*With Distributor Vacuum Ports on Carburetor Plugged.	

### DISTRIBUTOR VACUUM CONTROL

Model No. ....	1973408
Inches of Mercury to Start Advance .....	8-10
Inches of Mercury for Maximum Advance .....	18.5-20.5
Maximum Advance (Distributor Degrees)* .....	12.5
*Plus or Minus one Degree.	

### IGNITION COIL

Model No. ....	1115221
----------------	---------

### SPARK PLUGS

Make.....	AC
Type .....	R-45S
Size .....	18MM
Point Gap.....	.040"
Torque (Ft. Lbs.).....	35
Hex Size .....	13/16"
Distributor Clamp to Block Bolt (Ft. Lbs.).....	12-17

## STARTING SYSTEM

### GENERAL DESCRIPTION

The cranking circuit consists of the battery, the starting motor which includes a drive assembly for engaging the flywheel ring gear during cranking, the starter solenoid, mounted on the starting motor for shifting the drive assembly and closing the motor circuit, the ignition or control switch which, when in

the "START" position connects a lead from the battery to the solenoid switch and related electrical wiring. During cranking, the ignition switch also connects the battery directly to the ignition coil.

The solenoid operated overrunning clutch type starting motor, shown in Figure 39 is used on all Motor Homes.



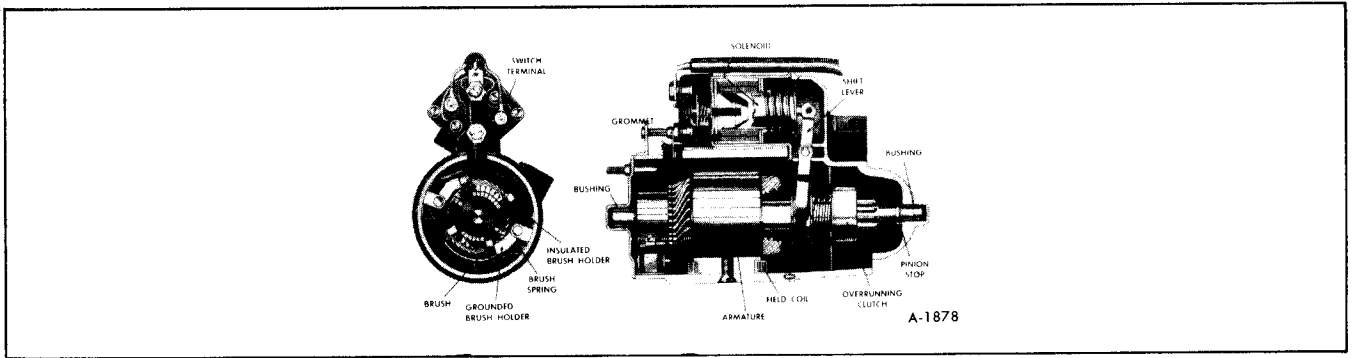

Figure 39-Starter Assembly

The drive end housing is extended to enclose the shift lever mechanism and solenoid plunger. The solenoid flange is mounted on drive end housing and sealing compound is used between the flange and field frame. A compression type shift lever return spring located inside the solenoid case is used to operate the overrunning clutch. The primary circuit to the ignition coil is fed from the solenoid while the starter is operating.

The solenoid contains two coil windings; the pull-in winding and the hold-in winding. Both windings are energized when ignition switch is closed to pull the plunger in and shift the drive pinion into mesh. The main contacts in the solenoid switch are closed to connect the battery directly to the cranking motor. Closing the main switch contacts will short out the pull-in winding. The magnetism produced by the hold-in winding is sufficient to hold the plunger in. When ignition switch is opened, the hold-in winding is disconnected from the battery; the shift lever spring withdraws the plunger from the solenoid opening the solenoid switch contacts while at the same time withdrawing the drive pinion from mesh.

## STARTING SYSTEM OPERATION

When starter circuit is energized, the solenoid operated shift lever slides the pinion into mesh with the flywheel ring gear teeth. The rotary motion between the pinion and ring gear, provided by spiral splines on armature shaft, normally relieves tooth abutment on the first attempt to engage pinion and the engine flywheel ring gear. When the engine is started, pinion overrun protects the armature from excessive speed until the ignition or control switch is released, at which time the solenoid shift lever return spring causes the pinion to disengage. To prevent excessive overrun on vehicles equipped with these starting motors, the ignition or control switch must be released immediately when engine starts.

## TROUBLE DIAGNOSIS

**Wiring:** Inspect the wiring for damage. Inspect all connections to the cranking motor, solenoid or magnetic switch, ignition switch or any other control switch, and battery, including all ground connections. Clean and tighten all connections as required.

**Magnetic Switch or Solenoid and Control Switches:** Inspect all switches to determine their condition. Connect a jumper lead around any switch suspected of being defective. If the system functions properly using this method, repair or replace the bypassed switch.

**Motor:** If the battery, wiring and switches are in satisfactory condition, and the engine is known to be functioning properly, remove the motor and follow the test procedures outlined.

Never operate the cranking motor more than 30 seconds at a time without pausing to allow it to cool for at least two minutes. Overheating, caused by excessive cranking will seriously damage the cranking motor.

## STARTER REMOVAL

1. Disconnect batteries by removing ground straps and hoist the Motor Home.
2. Remove two attaching bolts and move starter for easier access to wires.
3. Note the position of the wires and disconnect the wires from starter.
4. Remove the starter.

## CRANKING MOTOR TESTS

With the cranking motor removed from the en-

## STARTING CIRCUIT DIAGNOSIS

**STARTER SOLENOID OR STARTER CANNOT BE HEARD WHEN KEY IS IN START POSITION**  
(Parking Brake Must Be Fully Applied During Test)

1. Make sure connections are good at neutral or clutch start switch.
2. Turn on headlamps, turn ignition switch to "Start".

LAMPS DIM

LAMPS BRIGHT

Check for dirty or poor connection(s) at battery, solenoid and engine ground strap.

CONNECTION(S) POOR

Clean and tighten or replace as necessary.

BATTERY BAD

Recharge or replace as necessary.

CONNECTION(S) OK

Check condition and state of charge of battery.

BATTERY GOOD

1. Disconnect the two purple wires from neutral start switch.
2. Connect a jumper wire between the two wires in connector.
3. Turn ignition switch to "Start".

STARTER STILL DOES NOT OPERATE

Check purple wire from switch to starter, if OK, remove starter for repair.

STARTER NOW OPERATES

Replace neutral start switch.

**SOLENOID PUMPS IN AND OUT**  
Make Sure Selector Is In "Neutral" Or "Park"  
And Parking Brake Fully Applied

1. Connect voltmeter between purple wire terminal on solenoid and starter housing.
2. Turn key to "Start" and observe voltmeter oscillation.

LOWEST READING BELOW 7 VOLTS

1. Check for dirty or poor connections at battery, solenoid and engine ground strap.
2. Check condition and state of charge of battery.

BATTERY BAD

Recharge or replace as necessary.

LOWEST READING 7 VOLTS OR MORE

1. If all wiring and connections are good disconnect negative battery cable from battery.
2. Remove test and repair starter.

**SOLENOID CLICKS ONCE OR TWICE BUT STARTER DOES NOT TURN OR TURNS TOO SLOW**

Check for dirty or poor connection(s) at battery, solenoid and engine ground strap.

CONNECTIONS GOOD

Check condition and state of charge of battery.

BATTERY GOOD

Check for proper weight oil.

OIL OK

1. Connect red voltmeter lead to positive cable at battery, black lead to battery cable terminal of starter.
2. Crank engine and observe voltage.

LESS THAN 0.5 VOLTS

1. Connect voltmeter black lead to battery negative post and red lead to starter case.
2. Crank engine and observe voltage.

MORE THAN 0.2 VOLTS

Clean battery ground cable at both ends or replace cable as required.

CONNECTIONS POOR

Clean, tighten, or replace as necessary.

BATTERY BAD

Recharge or replace as necessary.

OIL TOO THICK

Drain and refill with recommended weight.

MORE THAN 0.5 VOLTS

Clean cable terminals or replace cable.

LESS THAN 0.2 VOLTS

Remove, test and repair starter.

**STARTER KEEPS RUNNING AFTER KEY IS RELEASED FROM "START" TO "RUN" POSITION**

Turn key to "Off".

STARTER STOPS

Replace ignition switch (key lock, linkage or ignition switch on column mounted units).

STARTER KEEPS RUNNING

1. Disconnect negative battery cable from battery.
2. Remove test and repair starter.

**STARTER SPINS AND/OR MAKES LOUD GRINDING NOISE BUT DOES NOT TURN ENGINE**

1. Disconnect negative battery cable from battery.
2. Remove, test and repair starter.
3. Examine ring gear for damage.

gine, the pinion should be checked for freedom of operation by turning it on the screw shaft. The armature should be checked for freedom of rotation by prying the pinion with a screwdriver. Tight bearings, a bent armature shaft, or a loose pole shoe screw will cause the armature to not turn freely. If the armature does not turn freely the motor should be disassembled immediately. However, if the armature does rotate freely, the motor should be given a no-load test before disassembly.

## NO-LOAD TEST (FIGURE 40)

Connect a voltmeter from the motor terminal to the motor frame, and use an rpm indicator to measure armature speed. Connect the motor and an ammeter in series with a fully charged battery of the specified voltage, and a switch in the open position from the solenoid battery terminal to the solenoid switch terminal. Close the switch and compare the rpm, current, and voltage readings with the specifications at the end of this section.

It is not necessary to obtain the exact voltage specified, as an accurate interpretation can be made by recognizing that if the voltage is slightly higher the rpm will be proportionately higher, with the current remaining essentially unchanged. However, if the exact voltage is desired, a carbon pile connected across the battery can be used to reduce the voltage to the specified value. If the specified current draw does not include the solenoid, deduct from the ammeter reading the specified current draw of the solenoid hold-in winding. Make disconnections only with the switch open. Interpret the test results as follows:

1. Rated current draw and no-load speed indicates normal condition of the cranking motor.

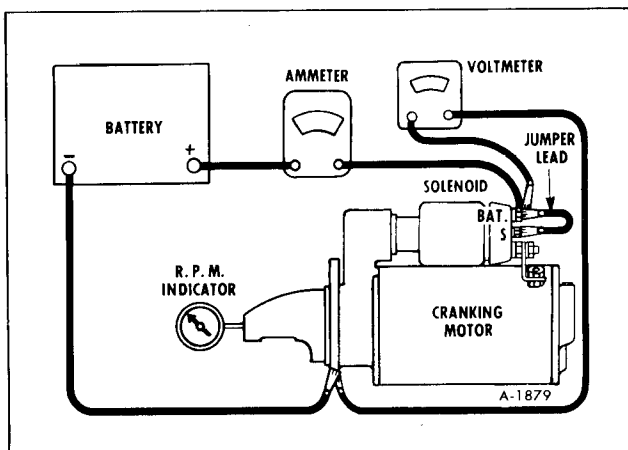

Figure 40—No-Load Test

2. Low free speed and high current draw indicates:

a. Too much friction—tight, dirty, or worn bearings, bent armature shaft or loose pole shoes allowing armature to drag.

b. Shorted armature. This can be further checked on a growler after disassembly.

c. Grounded armature or fields. Check further after disassembly.

3. Failure to operate with high current draw indicates:

a. A direct ground in the terminal or fields.

b. “Frozen” bearings (this should have been determined by turning the armature by hand).

4. Failure to operate with no current draw indicates:

a. Open field circuit. This can be checked after disassembly by inspecting internal connections and tracing circuit with a test lamp.

b. Open armature coils. Inspect the commutator for badly burned bars after disassembly.

c. Broken brush springs, worn brushes, high insulation between the commutator bars or other causes which would prevent good contact between the brushes and commutator.

5. Low no-load speed and low current draw indicates:

a. High internal resistance due to poor connections, defective leads, dirty commutator and causes listed under Number 4.

6. High free speed and high current draw indicate shorted fields. If shorted fields are suspected, replace the field coil assembly and check for improved performance.

## DISASSEMBLY (FIGURE 41)

If the motor does not perform in accordance with published specifications, it may need to be disassembled for further testing of the components. Normally the cranking motor should be disassembled only so far as is necessary to make repair or replacement of the defective parts. As a precaution, it is suggested that safety glasses be worn when disassembling or

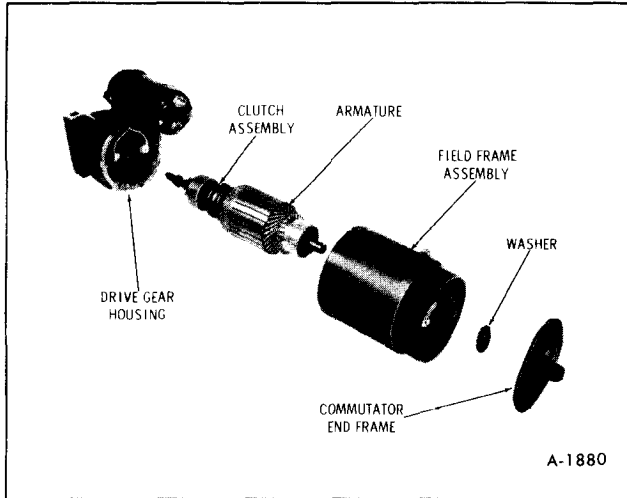

Figure 41-Starter Assembly Components

assembling the cranking motor. Following are general instructions for disassembling a typical overrunning clutch drive cranking motor:

1. Disconnect the field coil connector from the motor solenoid terminal.
2. Remove through-bolts, then remove commutator end frame and washer.
3. Remove field frame assembly, armature, and clutch assembly from drive gear housing.
4. If necessary to remove overrunning clutch from armature shaft, proceed as follows:
  - a. Remove thrust collar from armature shaft. (figure 42)

b. Slide a standard half-inch pipe coupling or other metal cylinder of suitable size (an old pinion can be used if available) over shaft against retainer to be used as a driving tool. (figure 43) With armature shaft supported on wood block, tap end of driving tool until retainer clears snap ring.

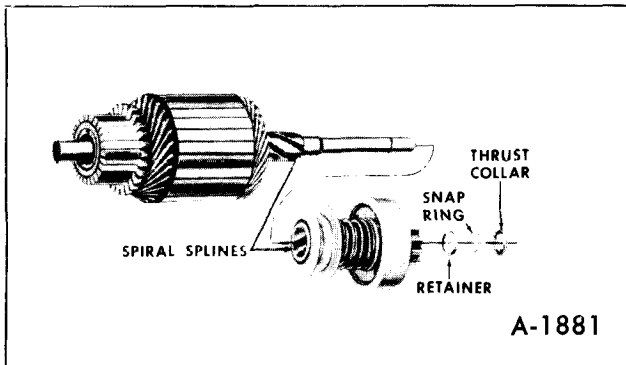

Figure 42-Starter Clutch

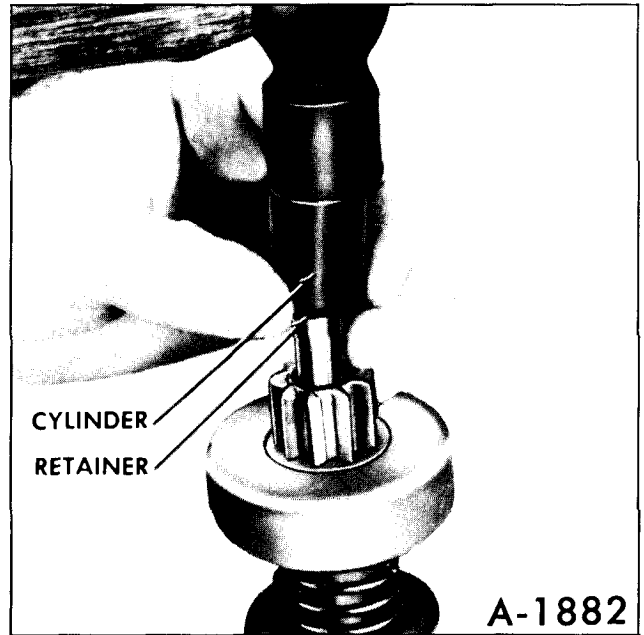

Figure 43-Removing Pinion Retainer

c. Remove snap ring from groove in shaft using pliers or other suitable tool. If the snap ring is distorted during removal, it will be necessary to use a new one upon reassembly.

d. Remove retainer and clutch assembly from armature shaft.

5. If necessary to replace brush holder parts, refer to Figure 44, then proceed as follows:

- a. Remove brush holder pivot pin which positions one insulated and one grounded brush.
- b. Remove brush spring.
- c. Replace brushes as necessary.

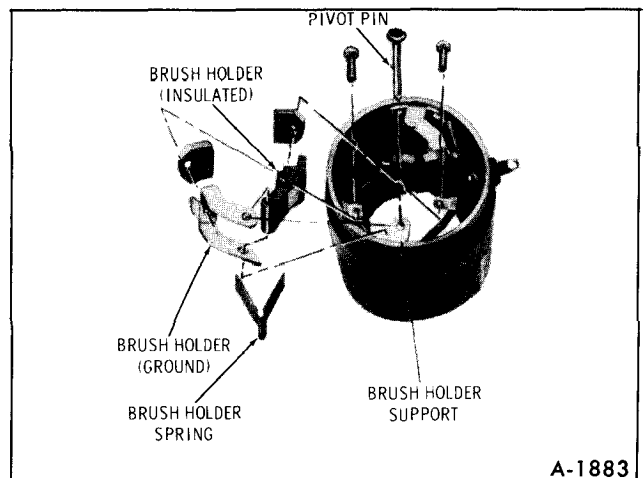

Figure 44-Brush Installation

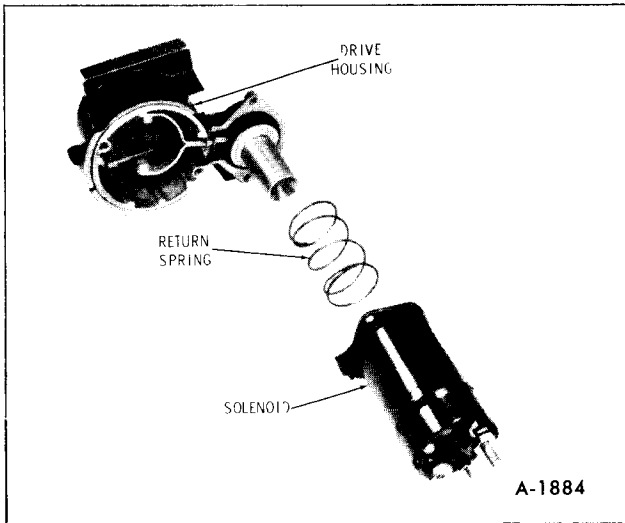

Figure 45—Solenoid Removal

6. If necessary to remove solenoid assembly or shift lever, proceed as follows:

- a. Remove solenoid to drive gear housing attaching screws, then remove solenoid assembly. (figure 45)
- b. To remove shift lever and/or plunger, remove shift lever pivot bolt (figure 46).
- c. Disassemble shift lever from plunger.

## CLEANING, INSPECTION AND TESTS

1. Clean all starting motor parts, but **DO NOT USE GREASE DISSOLVING SOLVENTS FOR CLEANING THE OVERRUNNING CLUTCH, ARMATURE, AND FIELD COILS**, since such

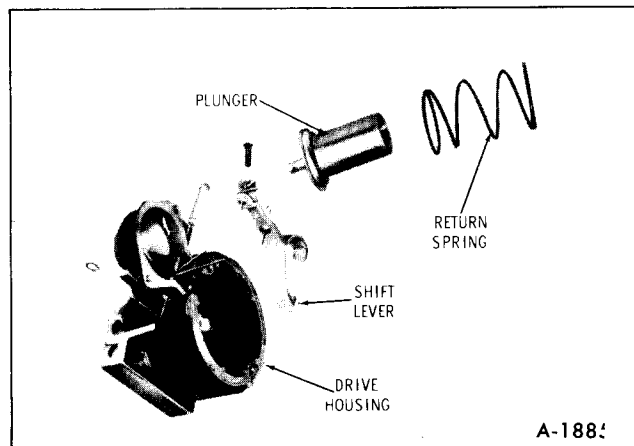

Figure 46—Shift Lever Removal

solvent would dissolve the grease packed in the clutch mechanism and would damage armature and field coil insulation.

2. Test overrunning clutch action. The pinion should turn freely in the overrunning direction. Check pinion teeth to see that they have not been chipped, cracked, or excessively worn. Replace clutch if worn or damaged.

3. Check brush holders to see that they are not deformed or bent and will properly hold brushes against the commutator.

4. Check fit of armature shaft in bushing in drive housing. Shaft should fit snugly in the bushing. If the bushing is worn, it should be replaced.

5. Inspect armature commutator. If commutator is rough or out-of-round, it should be turned down, do not undercut or turn to less than 1.650" O.D. Inspect the points where the armature conductors join the commutator bars to make sure they have a good connection. A burned commutator bar is usually evidence of a poor connection.

6. If test equipment is available:

- a. Check the armature for short circuits by placing on growler and holding hack saw blade over armature core while armature is rotated. If saw blade vibrates, armature is shorted. Recheck after cleaning between the commutator bars. If saw blade still vibrates, replace the armature.



Figure 47—Checking Shunt Field Coil

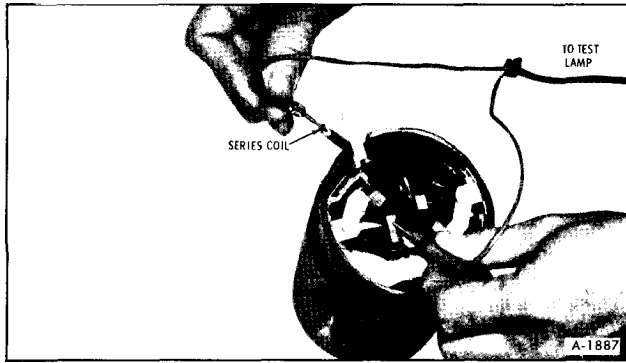

Figure 48—Checking Series Field Coil

b. Using a test lamp, place one lead on the shunt coil terminal and connect the other lead to a ground brush. (figure 47).

**NOTE:** This test should be made from both ground brushes to insure continuity through both brushes and leads. If the lamp fails to light, the field coil is open and will require repair or replacement.

c. Using a test lamp, place one lead on the series coil terminal and the other lead on the insulated brush. (figure 48) If the lamp fails to light, the series coil is open and will require repair or replacement.

**NOTE:** This test should be made from each insulated brush to check brush and lead continuity.

d. Using a test lamp, place one lead on the grounded brush holder and the other lead on either insulated brush. (figure 49) If the lamp lights, a grounded series coil is indicated and must be repaired or replaced.

e. Check the current draw of the solenoid winding as follows: (figure 50).

If solenoid is not removed from starting motor, the connector strap must be removed from the terminal on the solenoid before making these tests. Complete tests in a minimum of time to prevent overheating of the solenoid.

To check hold-in winding, connect an ammeter and a variable resistance in series with a 12-volt battery and the "switch" terminal on the solenoid. Connect a voltmeter to the "switch" terminal and to ground. Adjust the voltage to 10 volts and note the ammeter reading. It should be 14.5 to 16.5 amperes.

To check both windings, connect the ammeter, variable resistance and voltmeter as for previous test. Ground the solenoid motor terminal. Adjust the

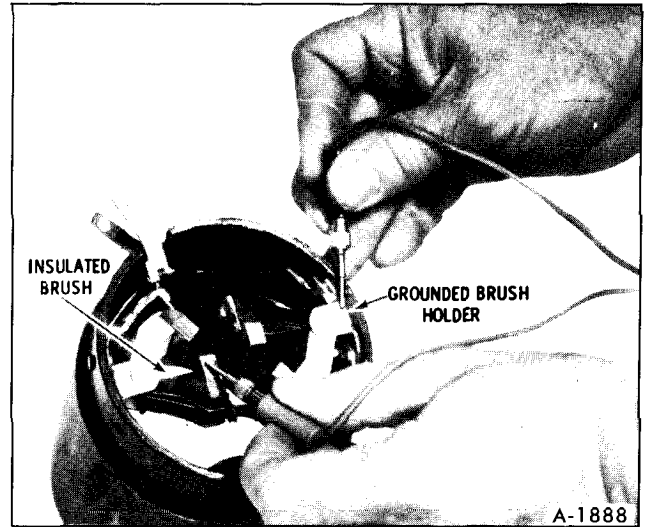

Figure 49—Checking Field Coil for Ground

voltage to 10 volts and note the ammeter reading. It should be 41 to 47 amperes for all starting motors.

Current draw readings that are over specifications indicate shorted turns or a ground in the windings of the solenoid and the solenoid should be replaced. Current draw readings that are under specifications indicate excessive resistance. No reading indicates an open circuit. Check connections then replace solenoid if necessary.

## ASSEMBLY

1. If the solenoid assembly or shift lever was removed, proceed as follows:

- a. Assemble shift lever and plunger.
- b. Position shift lever and plunger assembly in

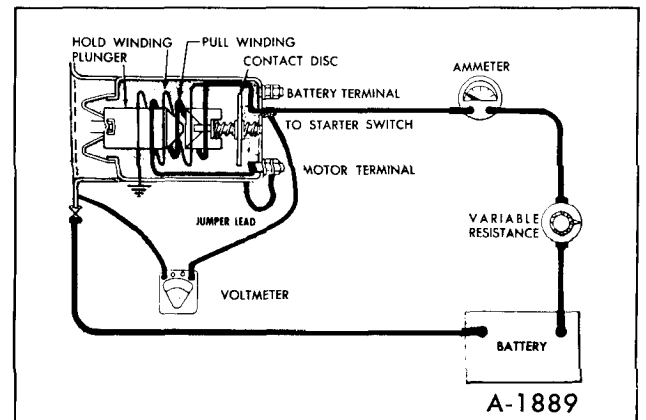

Figure 50—Checking Solenoid Wiring

drive gear housing and install lever pivot bolt. (figure 46)

c. Install solenoid assembly to drive gear housing. (figure 45)

2. If the overrunning clutch was removed from the armature shaft, assemble as follows:

a. Lubricate drive end of armature shaft with lubricant 1960954 or equivalent.

b. Slide clutch assembly onto armature shaft with pinion away from armature. (figure 42)

c. Slide retainer onto shaft with cupped surface facing away from clutch assembly.

d. Install snap ring into groove on armature shaft.

e. Assemble thrust collar onto shaft with shoulder next to snap ring.

f. Position retainer and thrust collar next to snap ring. Using two pliers, grip retainer and thrust collar and squeeze until snap ring is forced into retainer and is held securely in groove in armature shaft. (figure 51)

3. Lubricate drive gear housing bushing with lubricant 1960954 or equivalent.

4. With thrust collar in place against snap ring and retainer, slide armature and clutch assembly into drive gear housing and engage clutch with shift lever yoke.

5. Apply sealer, No. 1050026 or equivalent on solenoid flange as shown in (figure 52).

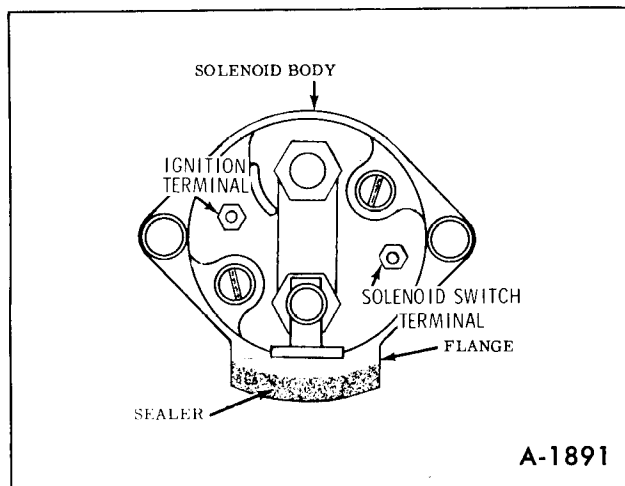

Figure 51—Installing Retainer and Snap Ring

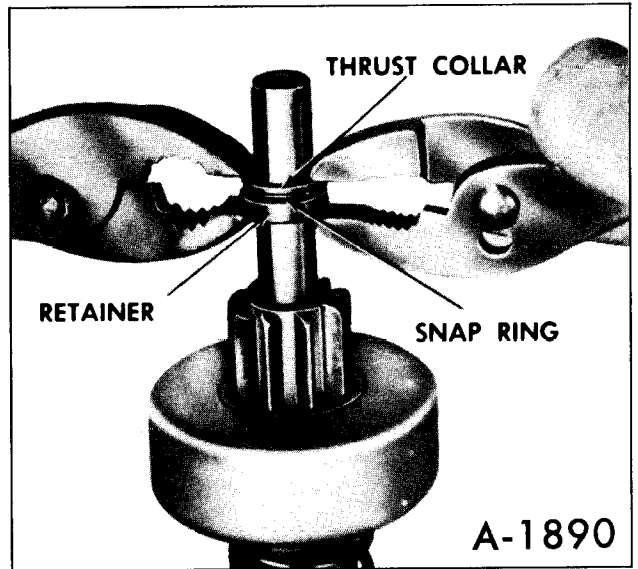

Figure 52—Solenoid Terminals and Sealing

6. Position field frame against drive gear housing using care to prevent damage to brushes.

7. Lubricate commutator end-frame bushing with lubricant 1960954 or equivalent.

8. Install washer on armature shaft and slide end frame onto shaft then install and tighten through-bolts.

9. Connect the field coil connector to the motor solenoid terminal.

PRESS ON CLUTCH AS SHOWN TO TAKE UP MOVEMENT

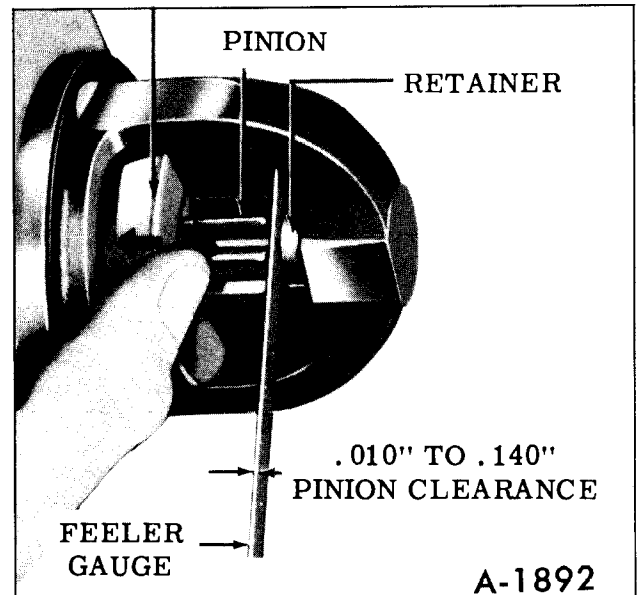

Figure 53—Checking Pinion Clearance

10. Check pinion clearance as outlined under PINION CLEARANCE.

### PINION CLEARANCE

Whenever the cranking motor has been disassembled or the solenoid has been replaced, it is necessary to check the pinion clearance. Pinion clearance must be correct to prevent the buttons on the shift lever yoke from rubbing on the clutch collar during cranking.

To check, connect a voltage source of approximately 6 volts between the solenoid switch terminal and ground. (figure 52).

**NOTE:** If a 6-volt battery is not available, a 12-volt battery may be used **PROVIDING ONLY THREE CELLS ARE CONNECTED IN SERIES. TO PREVENT MOTORING, CONNECT A HEAVY JUMPER LEAD FROM**

### THE SOLENOID MOTOR TERMINAL TO GROUND.

Energize the solenoid to shift the clutch, push the pinion back as far as possible to take up any movement, and check the clearance with a feeler gauge. (figure 53). The clearance should be .010" to .140".

Means for adjusting pinion clearance is not provided on the starter motor. If the clearance does not fall within limits, check for improper installation and replace all worn parts.

### STARTER INSTALLATION

1. Connect the wires to the starter solenoid.
2. Position starter motor and secure with two bolts.

## STARTER SPECIFICATIONS

STARTER MODEL	1108522
Make.....	Delco-Remy
Series .....	10 MT
Type .....	100
Rotation (viewed at Drive End) .....	CW
No Load Test	
Volts .....	9
Minimum Amps* .....	65*
Maximum Amps* .....	95*
Minimum RPM .....	7,500
Maximum RPM .....	10,500
Pinion Clearance .....	.010"- .140"
*Includes Solenoid	
<b>STARTER SOLENOID</b>	
Model .....	114356
Rated Voltage .....	12
Current Consumption	
Pull-In Winding	
Amps. ....	13.0-15.5
Volts .....	5
Hold-In Winding	
Amps. ....	14.5-16.5
Volts .....	10

## SPECIAL TOOLS

J-23600

Belt Tension Gauge





# SECTION 7

## TRANSMISSION

Contents of this section are listed below:

SUBJECT	PAGE NO.
General Information .....	7-1
Trouble Diagnosis .....	7-28
On Vehicle Servicing .....	7-42
Transmission Replacement .....	7-46
Transmission Overhaul .....	7-49
Transmission Specifications.....	7-86
Special Tools .....	7-86

## GENERAL INFORMATION

### DESCRIPTION

The Turbo Hydra-Matic transmission, Figure 1, is a fully automatic transmission used for front wheel drive applications.

The Turbo Hydra-matic transmission consists primarily of a three-element hydraulic torque converter, a dual sprocket and link assembly and a compound planetary gear set. Three multiple-disc clutches, a sprag unit, a roller clutch unit, and two bands provide the friction elements required to obtain the desired functions of the compound planetary gear set.

The torque converter, the dual sprocket and link, the clutches, the sprag and roller clutch, couple the engine to the planetary gears, providing three forward speeds and one reverse. The torque converter when required will supplement the gears by multiplying engine torque.

The torque converter is of welded construction and is serviced as an assembly. The unit is made up of two vaned sections, or halves, that face each other in an oil filled housing. The pump half of the converter is connected to the engine and the turbine half is, in effect, connected to the transmission.

The torque converter couples the engine to the planetary gear set through the use of a drive sprocket, a link assembly, and a driven sprocket. Clockwise engine torque turns the drive sprocket clockwise, which, in turn, drives the driven sprocket in a clockwise direction. This in effect is a reverse in the direction of engine torque due to the side mounting of the gear unit.

When the engine makes the converter pump revolve, it sends oil against the turbine, making it revolve also. The oil then returns in a circular flow back to the converter pump, continuing this flow as long as the engine is running.

The converter also has a smaller vaned section, called a stator, that funnels the oil back to the converter pump through smaller openings, at increased speed. The speeded up oil directs additional force to the engine-driven converter pump, thereby multiplying engine torque.

A hydraulic system pressurized by an internal-external type gear pump provides the working pressure required to operate the friction elements and automatic controls.

External control connections to the transmission are:

**Manual Linkage**—To select the desired operating range.

**Engine Vacuum**—To operate a vacuum modulator unit.

**12 Volt Electrical Signal**—To operate an electrical detent solenoid.

Gear or Torque ratios of the transmission are as follows:

First = 2.48:1 gear ratio

Second = 1.48:1 gear ratio

Third = 1.0:1 gear ratio

Reverse = 2.08:1 gear ratio

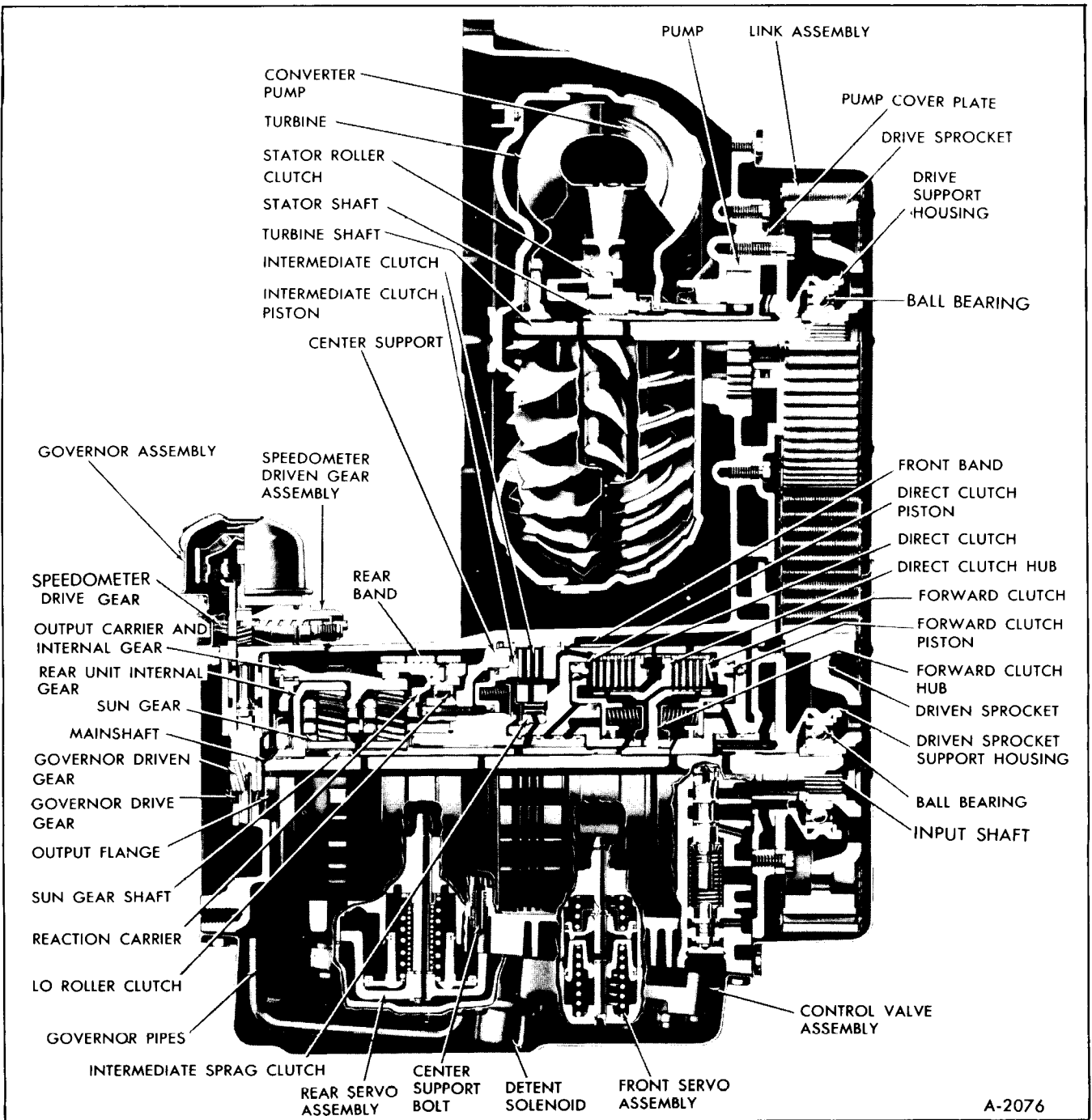

Figure 1-Turbo Hydra-matic Transmission

First and reverse gears can be multiplied by as much as 2.2:1, depending upon the slip speed of the converter pump and turbine.

A vacuum modulator is used to sense engine torque input to the transmission automatically. The vacuum modulator transmits this signal to the pressure regulator, which controls line pressure, so that all torque requirements of the transmission are met

and proper shift spacing is obtained at all throttle openings.

The downshift solenoid is activated by an adjustable switch at the accelerator pedal. When the throttle is opened sufficiently to close this switch, the solenoid in the transmission is activated, causing a downshift at speeds below approximately 70 miles per hour. At lower speeds, downshifts will occur at

lesser throttle openings without use of the switch.

The oil cooler is located in the right hand tank of the radiator. The transmission is cooled by directing oil from the converter to the radiator. Oil returning from the radiator feeds the transmission lubrication system.

The oil system incorporates an intake pipe and filter assembly. The filter assembly should be replaced after each 12,000 miles or 12 months.

The transmission quadrant has six selector positions that enable the driver to control the operation of the transmission under various driving conditions. The six selector positions appear on the quadrant in the following sequence, from left to right; PARK-park, R-reverse, N-neutral, D-drive, S-super, L-lo.

**PARK**—Park position positively locks the output flange to the transmission case by means of a locking pawl and prevents the vehicle from rolling either forward or backward. For this reason, it is recommended that the engine be started with transmission selector lever in Park position. If it is necessary to re-start the engine with vehicle rolling, place selector lever in Neutral and start the engine.

**R**—Reverse enables the vehicle to be operated in a reverse direction.

**N**—Neutral position enables the engine to be started and run without driving the vehicle. It is recommended that Neutral be used to start the engine only if it is necessary to re-start the engine with the vehicle rolling. At all other times use Park.

**D**—Drive is used for all normal driving conditions and maximum economy. Drive has three gear ratios from starting to direct drive. Downshifts are available for safe passing by depressing the accelerator pedal.

**S**—Super adds performance for congested traffic or engine braking in hilly terrain. The Super range has the same starting gear ratio as Drive, but prevents the transmission from shifting above second speed to retain acceleration when extra performance is desired.

**L**—Lo range permits operation at a lower gear ratio, and should be used where maximum engine braking is desired, such as in descending a steep grade. When selector lever is moved from Drive to Lo range at normal highway speeds, the transmission will shift to second gear and remain in second gear until vehicle speed is reduced to approximately 45 mph. The transmission will then shift to first gear and remain in first gear regardless of vehicle or engine speed, until selector lever is moved back into either Super or Drive position.

## HYDRAULIC SYSTEM

### PRESSURE CONTROL

The transmission is controlled automatically by a hydraulic system, Figure 2. Hydraulic pressure is supplied by the transmission oil pump, which is engine driven. Main line pressure is controlled by a pressure regulator valve train located in the transmission case and by the vacuum modulator which is connected to engine vacuum. The pressure regulator controls line pressure automatically, in response to a pressure signal from a modulator valve in such a way that the torque requirements of the transmission clutches are met and proper shift spacing is obtained at all throttle openings and vehicle speeds.

To control line pressure properly, modulator pressure is used which varies in the same manner as torque input to the transmission. Since the torque input to the clutches is the product of engine torque and converter ratio, modulator pressure must compensate for changes in either or both of these.

To meet these requirements, modulator pressure is regulated by engine vacuum, which is an indicator of engine torque, (Governor pressure also controls modulator pressure). It will decrease with an increase in vehicle speed to compensate for the changing converter torque ratio, by virtue of the governor pressure influence.

### VACUUM MODULATOR ASSEMBLY

The engine vacuum signal is received by the vacuum modulator, Figure 3, which consists of an

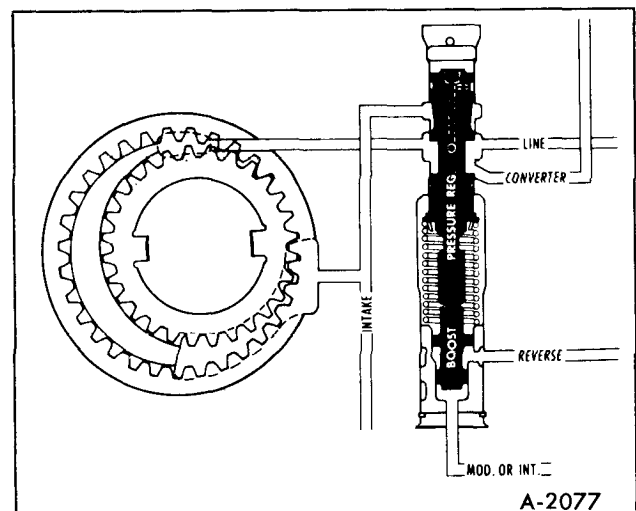
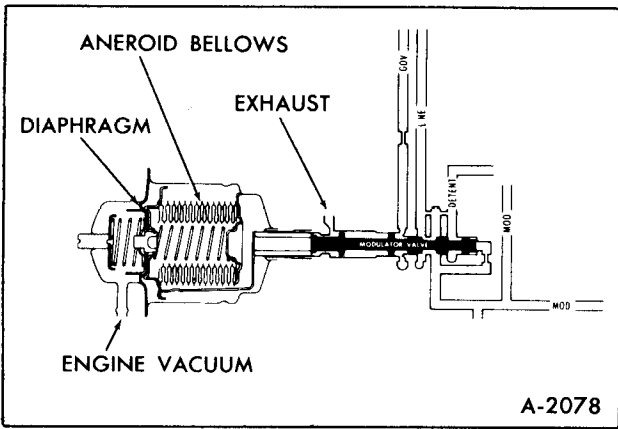

Figure 2—Pressure Control



**Figure 3-Vacuum Modulator Assembly**

evacuated metal bellows, a diaphragm and a spring. These are so arranged that the bellows and spring apply a force that acts on the modulator valve so that it increases modulator pressure.

Engine vacuum and the enclosed spring oppose the bellows and spring to control modulator pressure.

To reduce the effect of altitude on shift points, the effective area of the diaphragm is different than that of the bellows. Atmospheric pressure acts on the resulting differential area to reduce modulator pressure.

**GOVERNOR ASSEMBLY**

The vehicle speed signal to the transmission is supplied by the governor, which is driven by the output flange. The governor consists of flyweights and a regulator valve. Centrifugal force of the flyweights is imposed on the regulator valve, causing it to regulate a pressure signal that increases with speed.

Governor pressure acts on the modulator valve to cause modulator pressure to decrease as vehicle speed increases.

**FUNCTIONS OF VALVES AND HYDRAULIC CONTROL UNITS**

**Line Pressure Regulator**

Regulates line pressure to satisfy engine torque.

**Manual Valve**

Establishes the range of transmission operation,

PARK, R, N, D, S, or L, as selected by the vehicle operator through the manual selector lever.

**Governor Assembly**

Generates a speed sensitive oil pressure that increases with output shaft or vehicle speed. Governor pressure is used to control the shift points and modulator pressure regulation.

**Vacuum Modulator Valve**

Provides modulator pressure that senses engine torque and vehicle speed. The vacuum modulator is used to vary the shift points according to throttle opening and to raise line pressure proportional to input torque to the transmission.

**1-2 Shift Valve**

Activates the 1-2 and 2-1 shifts.

**1-2 Regulator Valve**

Controls the flow of modulator pressure to the 1-2 shift valve to regulate the minimum shift point.

**1-2 Detent Valve**

Senses regulated modulator pressure tending to hold 1-2 shift valve downshifted and provides an area for detent pressure for detent 2-1 shifts.

**2-3 Shift Valve**

Activates the 2-3 and 3-2 shifts.

**2-3 Modulator Valve**

Senses modulator pressure to apply a variable force that tends to hold the 2-3 shift valve downshifted.

**3-2 Valve**

Shuts off modulator pressure from acting on the shift valves after the direct clutch has been applied. This allows fairly heavy throttle operation in third speed without downshifting. In third speed, detent pressure or modulator pressure above 87 psi can be directed to the shift valves to provide the downshift forces.

**1-2 Accumulator Valve**

Regulates drive oil to a proportional lesser value

that increases as modulator pressure increases, to control engagement of the intermediate clutch.

### **Detent Valve**

Shifts when line oil is exhausted at the end of the valve when the detent solenoid is energized. This directs detent oil to the 1-2 and 2-3 modulator valves and allows the detent regulator valve to regulate.

### **Detent Regulator Valve**

When the detent valve shifts, the detent regulator is freed to allow drive oil to enter the detent passage and thus becomes regulated at 70 psi. Detent pressures will also flow into the modulator passage which flows to the shift valves. Detent pressure acting on the modulator valve limits the low limit of modulator pressure to the value of detent pressure.

### **Rear Servo and Accumulator Assembly**

The rear servo piston applies the rear band for engine braking in Lo range 1st gear. It applies the band in Reverse to hold the reaction carrier to provide the reverse gear ratio.

On the 1-2 shift in Drive or Super, the rear accumulator piston serves as an accumulator for the intermediate clutch to provide a smooth shift.

### **Front Servo**

The front servo piston applies the front band to provide engine braking in 2nd gear in Super and Lo ranges. The front accumulator piston cushions the apply of the direct clutch, and in conjunction with a series of check balls controlling orifices, is a part of the timing for the release of the direct clutch.

To prevent the apply of the front band in Neutral, Drive and Reverse ranges, oil is directed from the manual valve to the release side of the servo piston.

In Drive the servo release oil from the manual valve is used to charge the servo in preparation for the apply of the direct clutch.

Direct clutch oil is directed to the front servo accumulator piston where spring force plus direct clutch pressure stroke the piston up against the force of servo release oil. This lowers the clutch apply pressure for a smooth engagement.

The release of the direct clutch and the exhausting of the front servo accumulator is slowed down by the three check balls and three orifices which permits a soft return of the drive load to the intermediate roller clutch and also allows engine rpm to increase during a detent 3-2 downshift in preparation for the lower gear ratio, which results in a smooth shift and better acceleration.

## PARK OR NEUTRAL-ENGINE RUNNING

### POWER FLOW

Forward Clutch – Released

Roller Clutch – Ineffective

Direct Clutch – Released

Front Band – Released

Rear Band – Released

Intermediate Clutch – Released

Intermediate Sprag – Ineffective

In Neutral or Park no bands or clutches are applied, therefore no power is transmitted.

### OIL FLOW (FIGURE 4)

Whenever the engine is running at idle with the selector lever in “PARK” or “N”, oil from the pump is directed to the:

1. Converter
  - a. Oil Cooler
  - b. Lubrication System
2. Vacuum Modulator Valve
  - a. Pressure Regulator Boost Valve
  - b. 1-2 Accumulator and Primary Valves
  - c. Detent Valve
  - d. 3-2 Valve
  - e. 2-3 Shift Valve Train
  - f. 1-2 Shift Valve Train
3. Manual Valve
4. Detent Solenoid
5. Detent Valve
6. Front Servo Piston (Neutral only)

#### Cooling and Lubrication

Oil flows from the pump to the pressure regulator valve which regulates pump pressure. When the pump output exceeds the demand of line pressure, oil from the pressure regulator is directed to the converter feed passage to fill the converter. Oil from the converter is directed to the transmission cooler. Oil from the cooler is directed to the transmission lubrication system.

Line pressure acts on the:

1. Manual Valve
2. Detent Valve
3. Detent Solenoid
4. Modulator Valve
5. Front Servo Piston

Line pressure at the modulator valve is regulated to a pressure called modulator oil, which acts on the pressure boost valve, 1-2 accumulator and primary valves, and passes through the detent valve and 3-2 valve to the 1-2 and 2-3 valve trains.

#### Summary

The converter is filled. All clutches and bands are released. The transmission is in Neutral.

Figure 4-Neutral - Engine Running

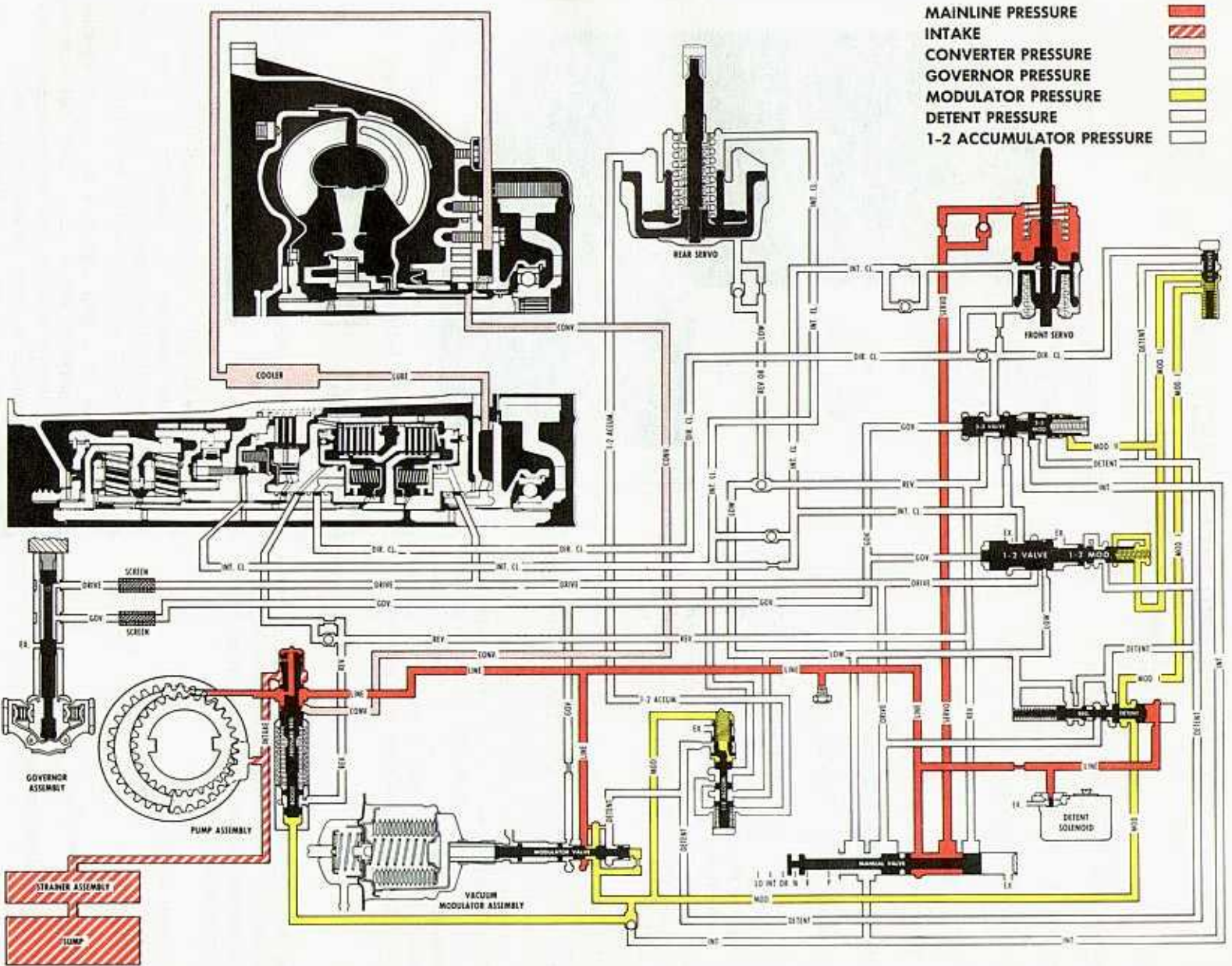

## DRIVE AND SUPER-FIRST SPEED

### POWER FLOW (FIGURE 5)

Forward Clutch – Applied

Roller Clutch – Effective

Direct Clutch – Released

Front Band – Released

Rear Band – Released

Intermediate Clutch – Released

Intermediate Sprag – Ineffective

With the selector lever in either Drive or Super Range, the forward clutch is applied. This delivers turbine torque to the drive sprocket, through the link assembly to the driven sprocket and mainshaft and turns the rear internal gear in a counterclockwise direction. (Converter torque ratio = approximately 2.2:1 at stall.)

Counterclockwise motion of the rear internal gear causes the rear pinions to turn counterclockwise to drive the sun gear clockwise. In turn, the sun gear drives the front pinions counterclockwise, thus turning the front internal gear, output carrier, and output flange counterclockwise in a reduction ratio of approximately 2.48:1. Reaction of the front pinions against the front internal gear is taken by reaction carrier and roller clutch assembly to the transmission case. (Approximate stall ratio – 5:1).

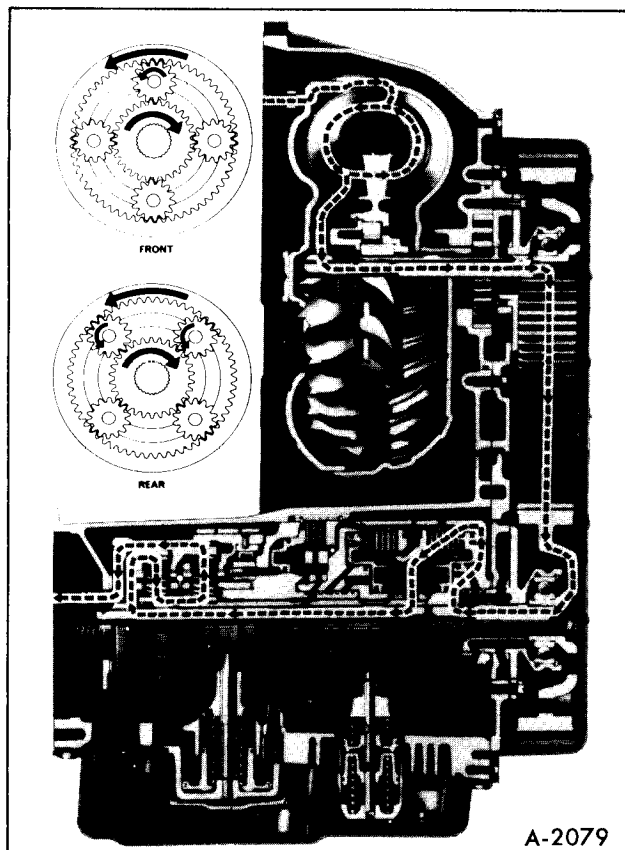

Figure 5–Drive Range–First Gear (Power)

### OIL FLOW (FIGURE 6)

When the selector lever is moved to either Drive or Super position, the manual valve is repositioned to allow line pressure to enter the drive circuit. Drive oil then flows to the:

1. Forward Clutch
2. 1-2 Shift Valve
3. Governor Assembly
4. 1-2 Accumulator Valve
5. Detent Regulator Valve

#### Basic Control

Drive oil is directed to the forward clutch where it acts on two areas of the clutch piston to apply the forward clutch. The first, or inner area, is fed

through an unrestricted passage. The outer area is fed through an orifice to insure a smooth shift into Drive.

Drive oil at the governor assembly is regulated to a variable pressure. This pressure increases with vehicle speed and acts against the ends of the 1-2 and 2-3 shift valves and an area on the modulator valve.

Drive oil is also regulated to another variable pressure at the 1-2 accumulator valve. This pressure is controlled by modulator oil and is directed to the rear accumulator piston. In addition, to maintain the lower pressure in the 1-2 accumulator passage, the 1-2 accumulator valve intermittently uncovers the lo oil passage and oil is exhausted at the manual valve.

#### Summary

The converter is filled. The forward clutch is applied. The transmission is in first gear.



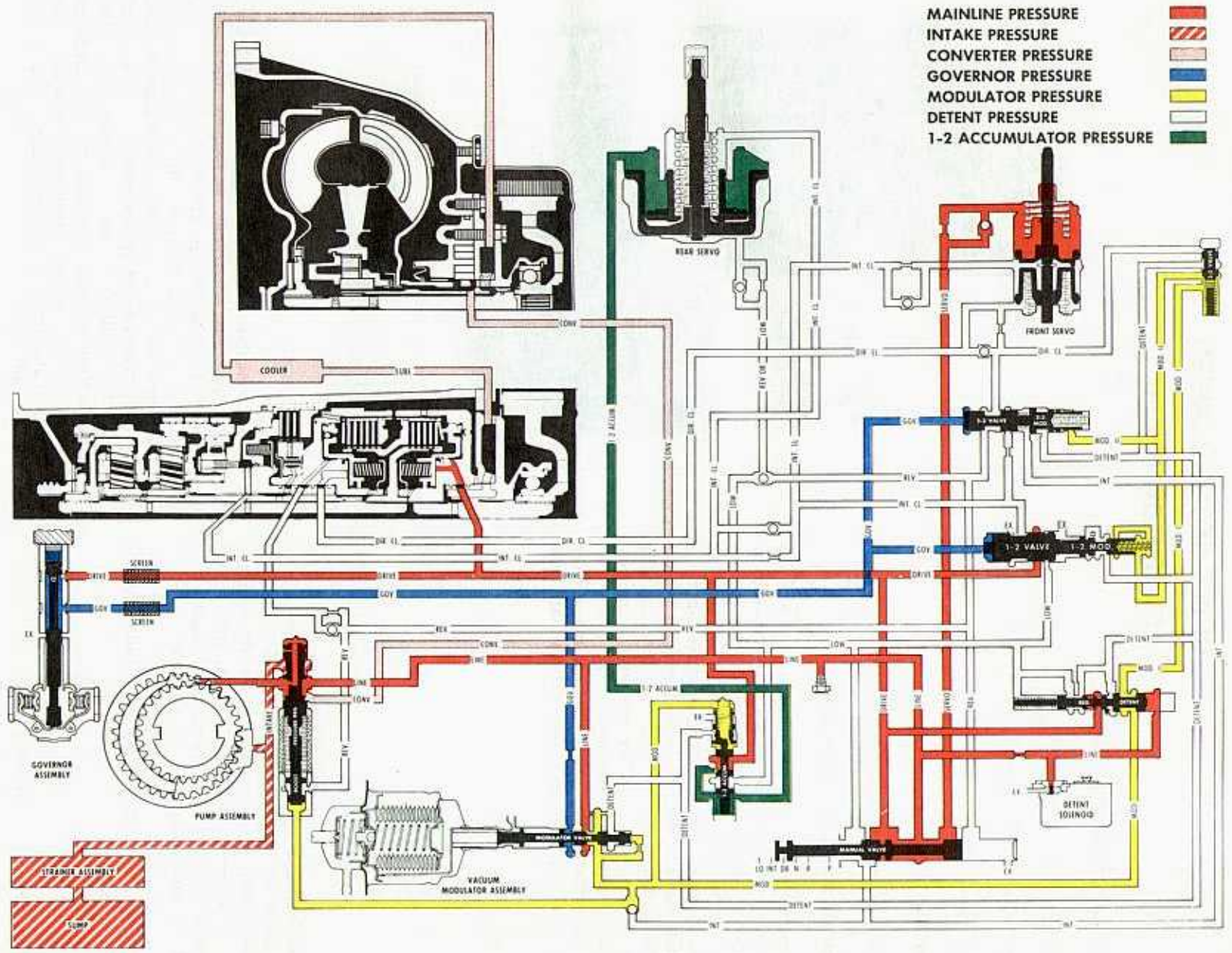

Figure 6-Drive Range-First Gear (Oil)

**DRIVE-SECOND SPEED****POWER FLOW (FIGURE 7)**

- Forward Clutch – Applied
- Roller Clutch – Ineffective
- Direct Clutch – Released
- Front Band – Released
- Rear Band – Released
- Intermediate Clutch – Applied
- Intermediate Sprag – Effective

In second speed, the intermediate clutch is applied to allow the intermediate sprag to hold the sun gear against clockwise rotation. Turbine torque through the forward clutch is now applied through the drive sprocket, link assembly and driven sprocket to the mainshaft to the rear internal gear in a counterclockwise direction. Counterclockwise rotation of the rear internal gear turns the rear pinions counterclockwise against the stationary sun gear. This causes the output carrier and output flange to turn counterclockwise in a reduction ratio of approximately 1.48:1.

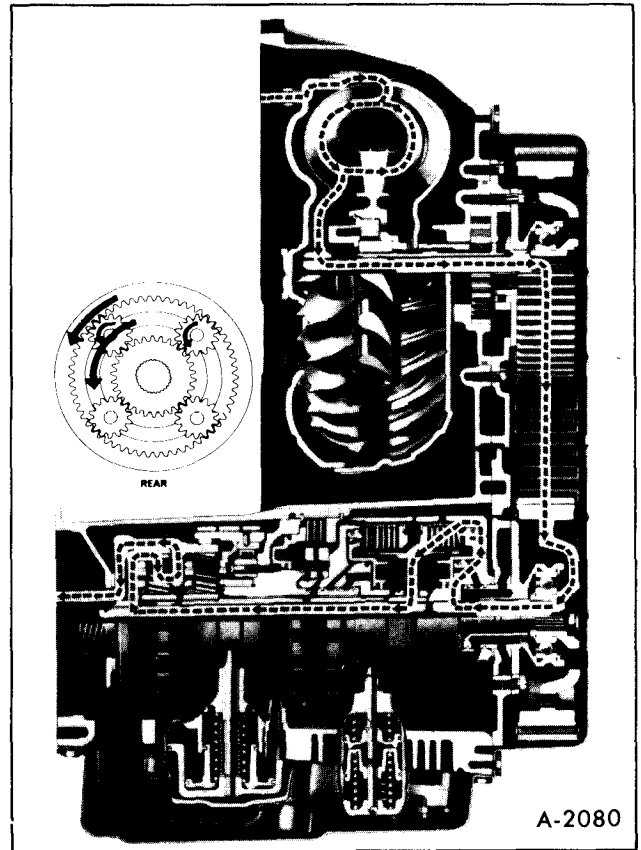

Figure 7-Drive-Second Gear (Power)

**OIL FLOW (FIGURE 8)**

As both vehicle speed and governor pressure increase, the force of governor oil acting on the 1-2 shift valve will overcome the force of regulated modulated oil pressure and the 1-2 valve spring. This allows the 1-2 shift valve to open, permitting drive oil to enter the intermediate clutch passage.

Intermediate clutch oil from the 1-2 shift valve is directed to the:

1. Intermediate Clutch
2. Rear Servo Accumulator
3. Front Servo Accumulator
4. 2-3 Shift Valve

**Basic Control**

Intermediate clutch oil from the 1-2 shift valve seats a one-way check ball and flows through an orifice to the intermediate clutch. At the same time, intermediate clutch oil moves the accumulator piston against the 1-2 accumulator oil and accumulator spring to maintain controlled pressure in the clutch during a 1-2 shift for a smooth clutch apply. Intermediate clutch oil seats a second one-way check ball and flows to the front servo and accumulator pistons. Intermediate clutch oil is also directed to a land of the 2-3 shift valve.

**Summary**

The forward and intermediate clutches are applied. The transmission is in second speed.



Figure 8-Drive-Second Gear (Oil)

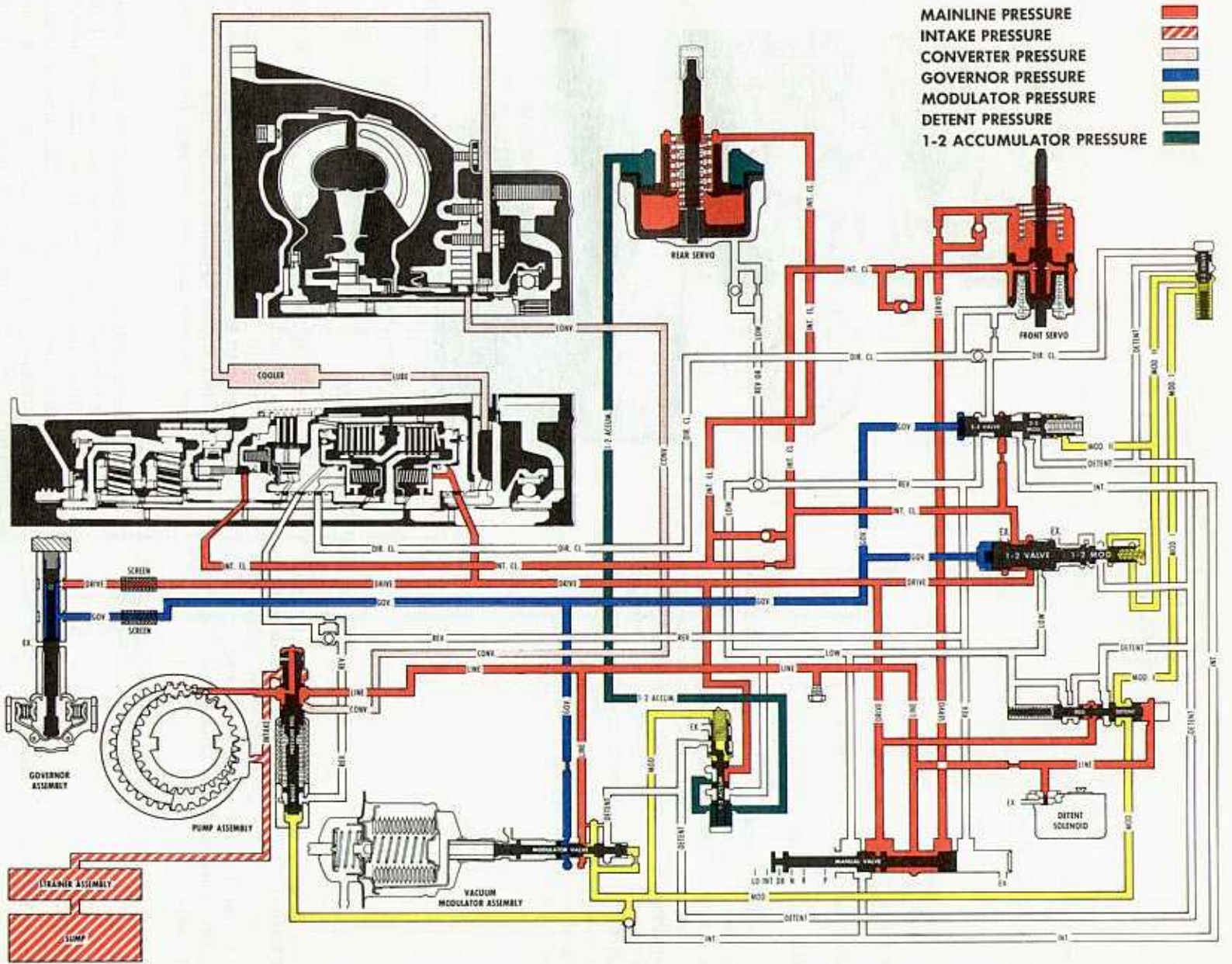

## DRIVE-THIRD SPEED POWER FLOW (FIGURE 9)

- Forward Clutch – Applied
- Roller Clutch – Ineffective
- Direct Clutch – Applied
- Front Band – Released
- Rear Band – Released
- Intermediate Clutch – Applied
- Intermediate Sprag – Ineffective

In direct drive, engine torque is transmitted from the converter to the drive sprocket, through the link assembly, to the driven sprocket and through the forward clutch to the mainshaft and rear internal gear. Because the direct clutch is applied, equal power is transmitted to sun gear shaft and sun gear. Since both sun gear and internal gears are now turning at the same speed, the planetary gear set is essentially locked and turns as one unit in direct drive or a ratio of 1:1.

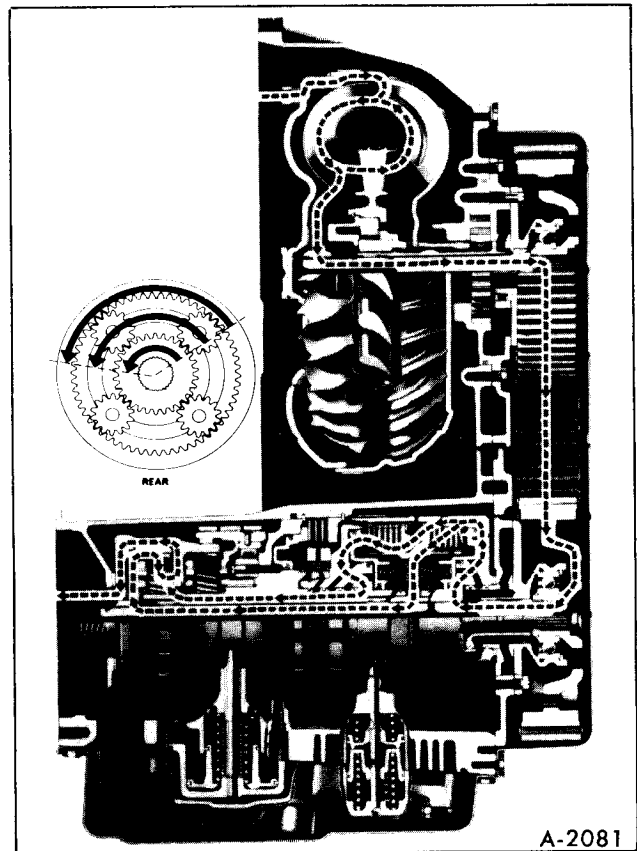

Figure 9—Drive—Third Gear (Power)

## OIL FLOW (FIGURE 10)

As vehicle speed and governor pressure increase, force of governor oil acting on the 2-3 shift valve overcomes the force of 2-3 shift valve spring and modulator oil. This allows the 2-3 shift valve to move, feeding intermediate clutch oil to the direct clutch passage.

Direct clutch oil from the 2-3 shift valve is directed to the:

1. Direct Clutch
2. Front Accumulator Piston
3. 3-2 Valve

### Basic Control

Direct clutch oil from the 2-3 shift valve flows past a one-way check valve to the inner area of the

direct clutch piston to apply the direct clutch. Simultaneously, direct clutch oil is fed to the front accumulator piston. Pressure of the direct clutch oil, combined with the accumulator spring, moves the accumulator and servo pistons against servo oil. This acts as an accumulator for a smooth direct clutch apply.

Direct clutch oil is also supplied to the 3-2 valve to move the valve against modulator pressure. This cuts off modulator oil to the 1-2 modulator and 2-3 modulator valves and allows the transmission to utilize the torque multiplying characteristics of the converter during medium throttle operation without downshifting.

### Summary

The forward, intermediate and direct clutches are applied. The transmission is in third gear (direct drive).



Figure 10-Drive-Third Gear (Oil)

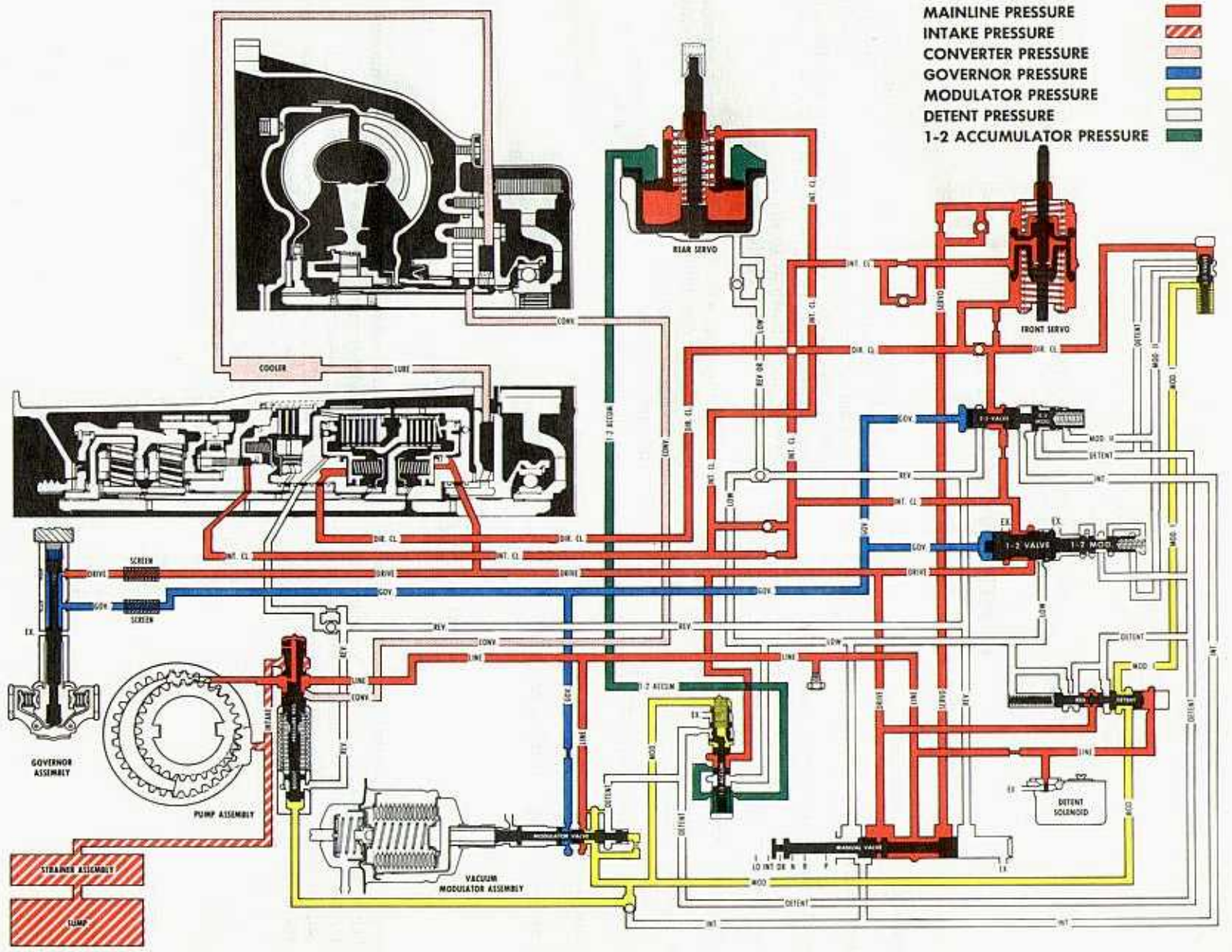

## PART THROTTLE 3-2 DOWNSHIFT

### POWER FLOW (FIGURE 11)

- Forward Clutch – Applied
- Roller Clutch – Ineffective
- Direct Clutch – Released in 2nd
- Direct Clutch – Applied in 3rd
- Front Band – Released
- Rear Band – Released
- Intermediate Clutch – Applied
- Intermediate Sprag – Effective in 2nd
- Intermediate Sprag – Ineffective in 3rd

In second speed, Figure 8, The intermediate clutch is applied to allow the intermediate sprag to hold the sun gear against clockwise rotation. Turbine torque through the drive sprocket, link assembly and driven sprocket to the forward clutch is now applied through the mainshaft to the rear internal gear in a counterclockwise direction.

Counterclockwise rotation of the rear internal gear turns the rear pinions counterclockwise against the stationary sun gear. This causes the output carrier and output flange to turn counterclockwise in a reduction ratio of approximately 1.48:1.

### OIL FLOW (FIGURE 11)

A part throttle 3-2 downshift can be accomplished below approximately 30 mph by depressing the accelerator far enough to raise modulator pressure to approximately 81 psi. Modulator pressure and 3-2 valve spring will move the 3-2 valve against

direct clutch oil and allow modulator oil to act on the 2-3 modulator valve, moving it against the 2-3 shift valve and governor oil. The transmission will then shift to second speed, as the direct clutch oil passages are open to exhaust through lo-oil passages.

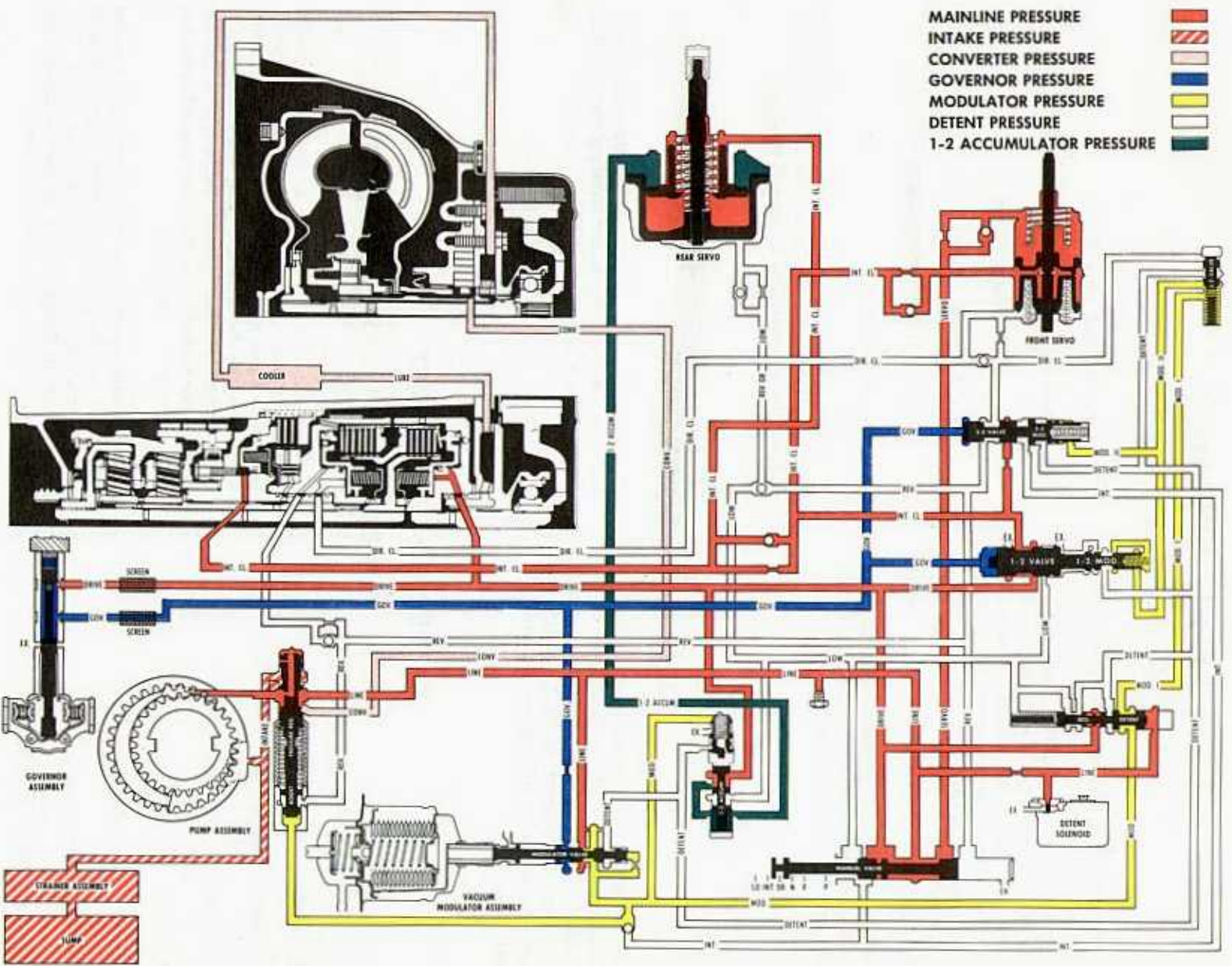

Figure 11-Part Throttle 3-2 Downshift



## DETENT DOWNSHIFT

### OIL FLOW (FIGURE 12)

While operating at speeds below approximately 70 mph a forced or detent 3-2 downshift is possible by depressing the accelerator fully. This energizes the switch at the accelerator pedal lever and actuates the detent solenoid. The detent solenoid opens an orifice that allows line oil at the detent valve to be exhausted, thus permitting the detent regulator valve to operate. Line oil acting on the detent valve and solenoid is supplied by a small orifice.

Drive oil on the detent regulator valve is then regulated to a pressure of approximately 70 psi and called detent oil. Detent oil is then routed to the:

#### 1. Modulator passages

##### a. 3-2 Valve

##### b. 2-3 Modulator Valve

#### 2. Detent Passages

##### a. 1-2 Modulator Valve

##### b. 2-3 Modulator Valve

##### c. 1-2 Primary Accumulator Valve

##### d. Modulator Valve

Detent oil in the modulator passage and at the 2-3 modulator valve will close the 2-3 shift valve, shifting the transmission to second gear.

## DETENT 2-1 DOWNSHIFT

A detent 2-1 downshift can also be accomplished below approximately 25 mph because detent oil is directed to the 1-2 regulator valve. This allows detent oil to act on the 1-2 regulator, and 1-2 detent valve to close the 1-2 shift valve, shifting the transmission to first gear.

Detent oil is also directed to the modulator valve to prevent modulator pressure from regulating below 70 psi at high speeds or at high altitudes.

## DETENT 3-2 DOWNSHIFT

### POWER FLOW

Forward Clutch – Applied

Roller Clutch – Ineffective

Direct Clutch – Released in 2nd

Direct Clutch – Applied in 3rd

Front Band – Released

Rear Band – Released

Intermediate Clutch – Applied

Intermediate Sprag – Effective in 2nd

Intermediate Sprag – Ineffective in 3rd

In second speed, Figure 8, the intermediate clutch is applied to allow the intermediate sprag to hold the sun gear against clockwise rotation. Turbine torque through the drive sprocket, link assembly and driven sprocket to the forward clutch is now applied through the mainshaft to the rear internal gear in a counterclockwise direction.

Counterclockwise rotation of the rear internal gear turns the rear pinions counterclockwise against the stationary sun gear. This causes the output carrier and output flange to turn counterclockwise in a reduction ratio of approximately 1.48:1.



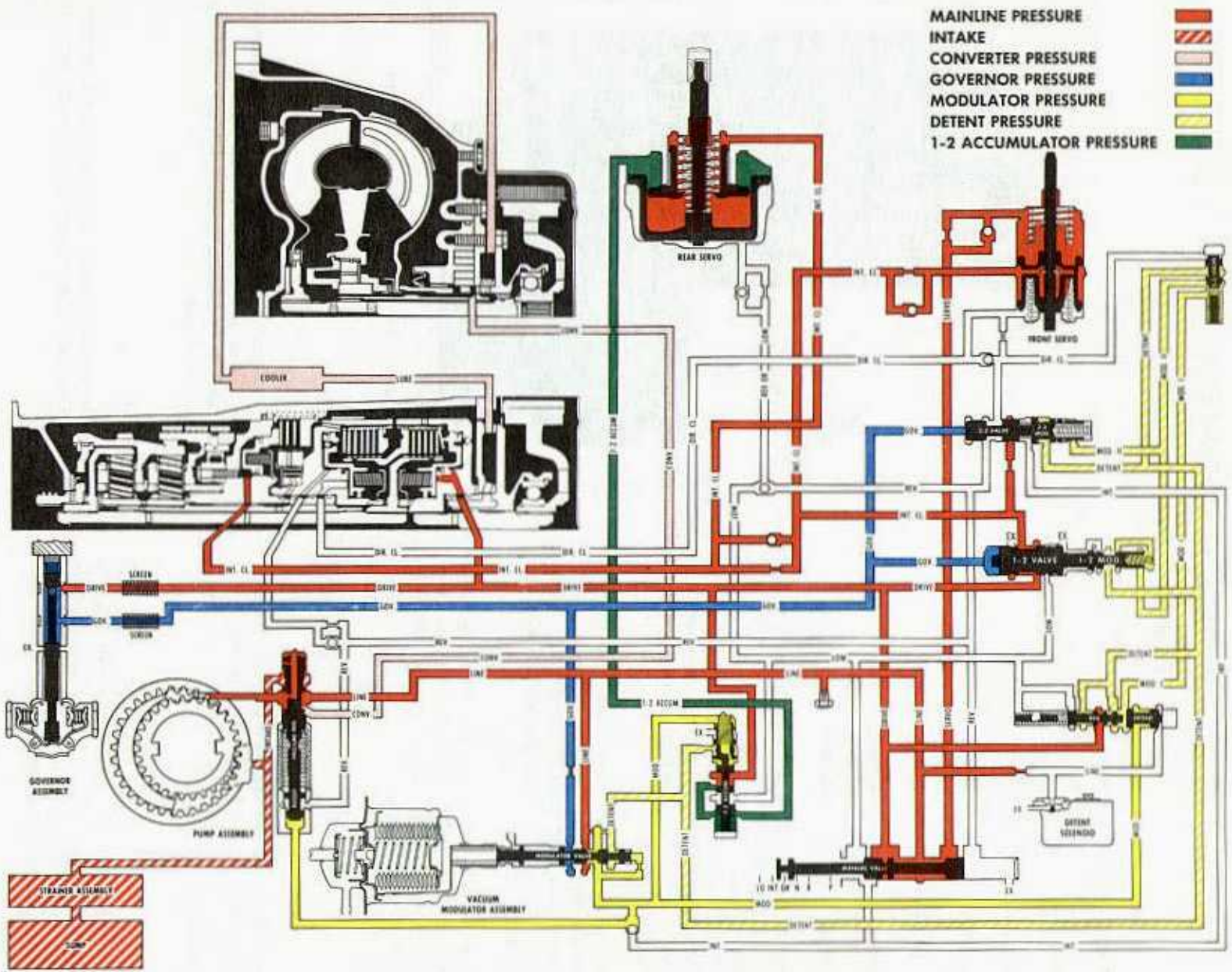

Figure 12-Detent 3-2 Downshift

## SUPER-SECOND SPEED POWER FLOW (FIGURE 13)

Forward Clutch – Applied

Roller Clutch – Ineffective

Direct Clutch – Released

Front Band – Applied

Rear Band – Released

Intermediate Clutch – Applied

Intermediate Sprag – Effective

In second speed, the intermediate clutch is applied to allow the intermediate sprag to hold the sun gear against clockwise rotation. Turbine torque through the drive sprocket, link assembly and driven sprocket to the forward clutch is now applied through the mainshaft to the rear internal gear in a counterclockwise direction.

Counterclockwise rotation of the rear internal gear turns the rear pinions counterclockwise against the stationary sun gear. This causes the output carrier and output flange to turn counterclockwise in a reduction ratio of approximately 1.48:1.

In second speed – Super, engine braking is provided by the front band as it holds the sun gear fixed. Without the band applied, the sun gear would overrun the intermediate sprag.

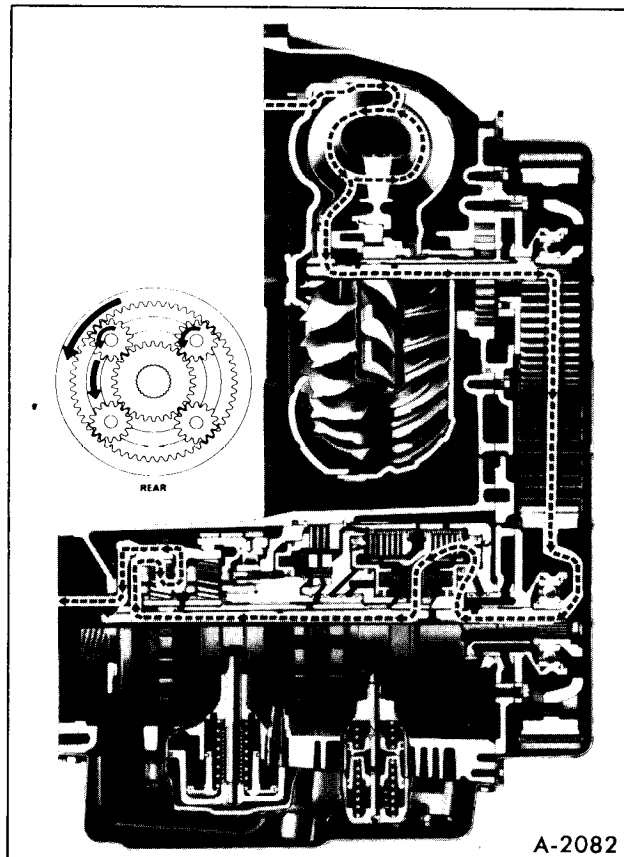

Figure 13-Super-Second Gear (Power)

## OIL FLOW (FIGURE 14)

When the selector lever is in Super, intermediate oil from the manual valve is directed to the:

1. Pressure Boost Valve
2. 2-3 Shift Valve

Intermediate oil at the boost valve will increase line pressure to 150 psi. This increased intermediate oil pressure at the 2-3 shift valve will close the 2-3 shift valve, regardless of vehicle speed.

For engine braking the front band is applied by exhausting servo oil at the manual valve. This allows

intermediate clutch oil, acting on the servo piston, to move the piston and apply the front band. Once the transmission is in second speed – Super, it cannot upshift to third gear.

### Summary

The forward and intermediate clutches and front band are applied. The transmission is in second gear – Super.



Figure 14-Super-Second Gear (Oil)

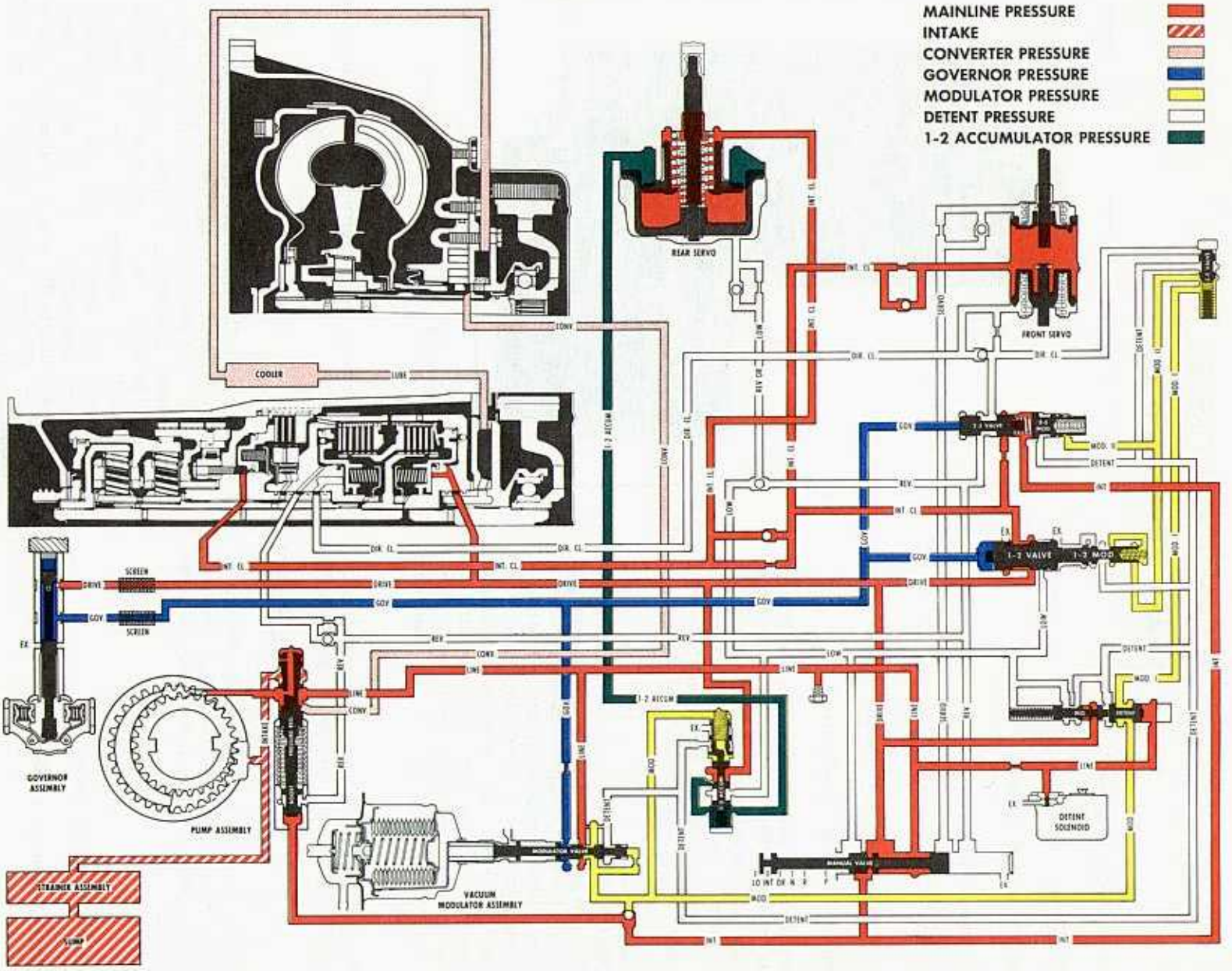

## LO RANGE-FIRST SPEED POWER FLOW (FIGURE 15)

- Forward Clutch – Applied
- Roller Clutch – Effective
- Direct Clutch – Released
- Front Band – Released
- Rear Band – Applied
- Intermediate Clutch – Released
- Intermediate Sprag – Ineffective

With the selector lever in Lo range, the forward clutch is applied. This delivers turbine torque, through the drive sprocket, link assembly and driven sprocket, to the mainshaft and turns the rear internal gear in a counterclockwise direction. (Converter torque ratio = approximately 2.2:1 at stall.)

Counterclockwise motion of the rear internal gear causes the rear pinions to turn counterclockwise to drive the sun gear clockwise. In turn, the sun gear drives the front pinions counterclockwise, thus turning the front internal gear, output carrier, and output flange counterclockwise in a reduction ratio of approximately 2.48:1. The reaction of the front pinions against the front internal gear is taken by the reaction carrier and roller clutch assembly to the transmission case. (Total stall ratio = approximately 5.46:1).

Downhill or overrun braking is provided in Lo range by applying the rear band, as this prevents the

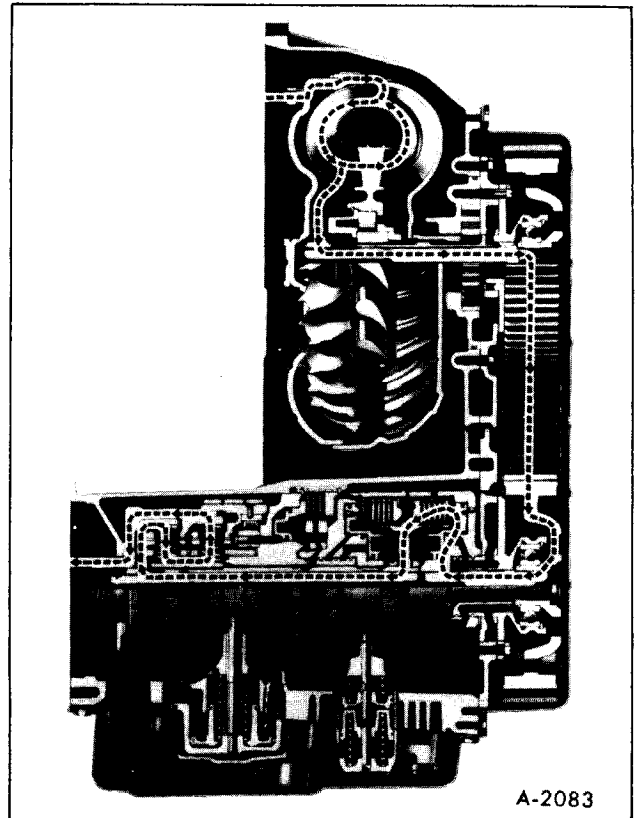

Figure 15-Lo Range-First Gear (Power)

reaction carrier from overrunning the Lo roller clutch.

## OIL FLOW (FIGURE 16)

Maximum downhill braking can be attained at speeds below approximately 45 mph, with the selector lever in Lo position as this directs Lo oil from the manual valve to the:

1. Rear Servo
2. 1-2 Accumulator Valve
3. Detent Regulator Valve
4. 1-2 Shift Valve

### Basic Control

Lo oil flows past a ball check to the apply side of the rear servo piston and to the 1-2 accumulator valve to raise the 1-2 accumulator oil to line pressure for a smooth band apply. Lo oil acts on the detent

regulator valve. Combined with the detent spring, Lo oil holds the detent valve against line oil acting on the detent valve, causing drive oil to flow through the detent regulator valve into the detent and modulator passages. Modulator and detent oil at line pressure acting on the 1-2 modulator valve overcomes governor oil and Lo oil on the 1-2 shift valve at any vehicle speed below approximately 40 mph, and the transmission will shift to first gear. Lo oil acts on a small area of the 1-2 shift valve to prevent the 2-1 shift occurring at too high a vehicle speed.

In first speed – Lo range, the transmission cannot upshift to second speed regardless of vehicle or engine speed.

### Summary

The forward clutch and rear band are applied. The transmission is in first speed – Lo range.



Figure 16-Lo Range-First Gear (Oil)

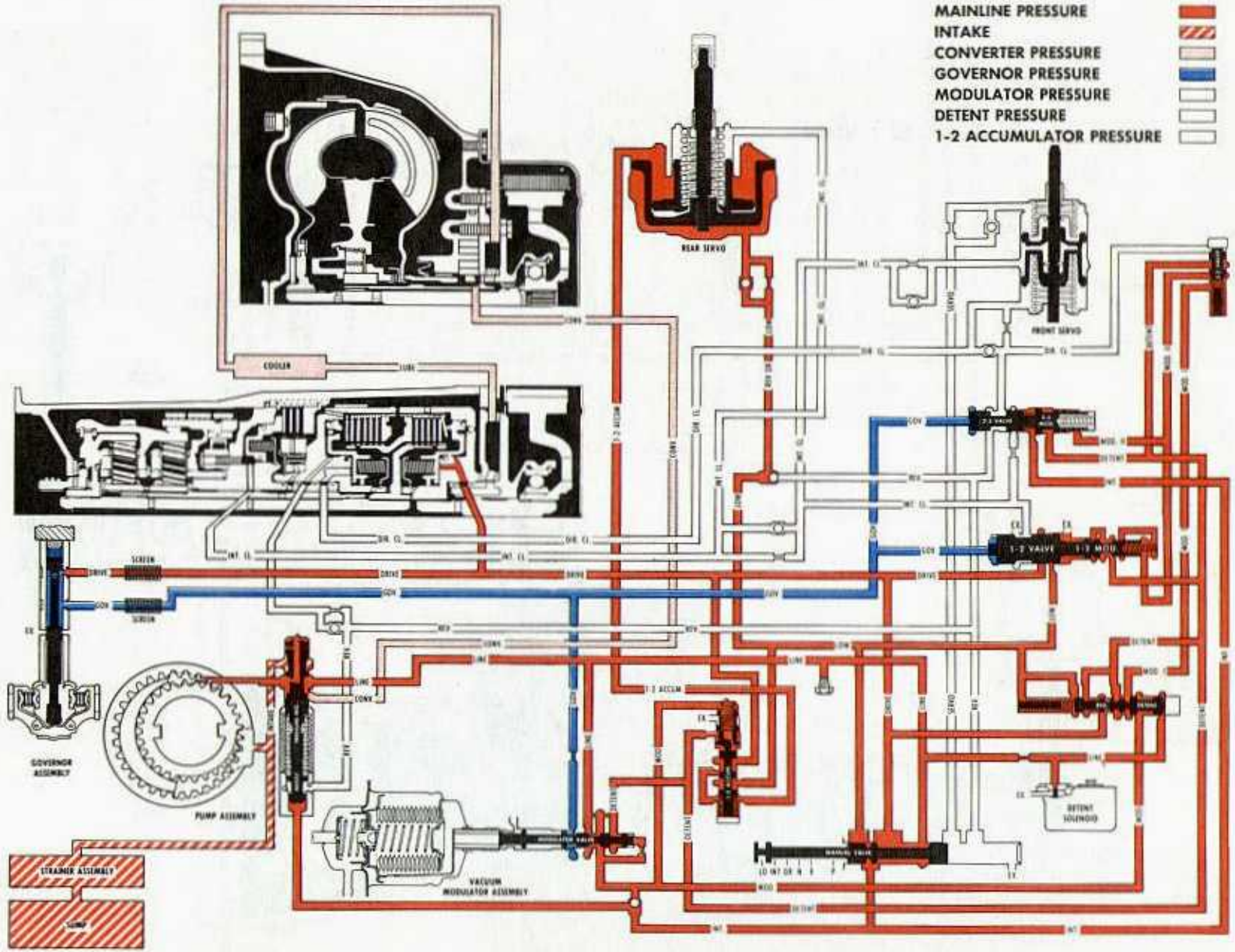

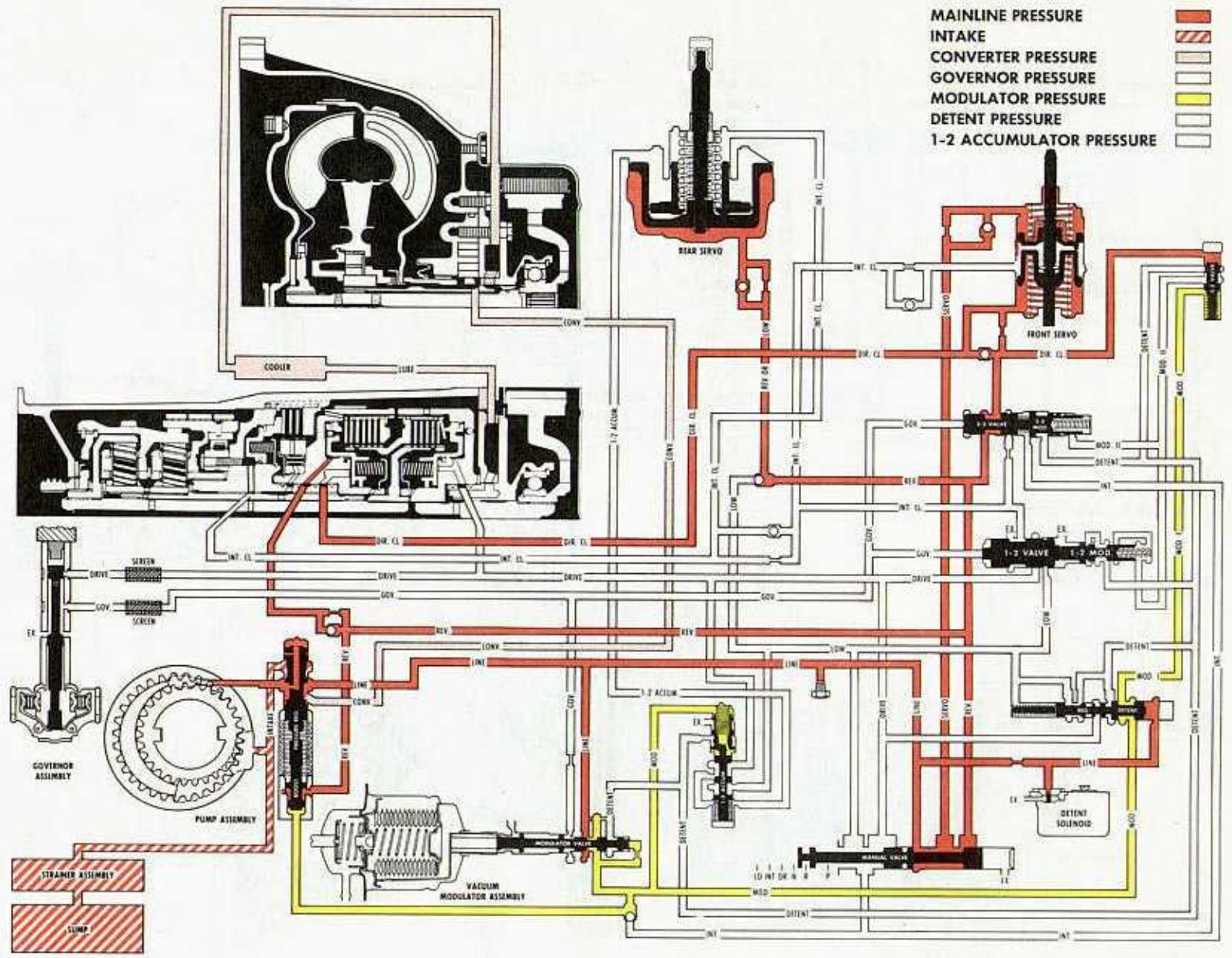

Figure 18-Reverse (Oil)



## REVERSE

### POWER FLOW (FIGURE 17)

Forward Clutch – Released

Roller Clutch – Ineffective

Direct Clutch – Applied

Front Band – Released

Rear Band – Applied

Intermediate Clutch – Released

Intermediate Sprag – Ineffective

In Reverse, the direct clutch is applied to direct turbine torque through the drive sprocket, link assembly and driven sprocket to the sun gear shaft and sun gear. The rear band is applied, holding the reaction carrier.

Counterclockwise torque to the sun gear causes the front pinions and front internal gear to turn clockwise in reduction. The front internal gear is connected directly to the output flange, thus providing the reverse output gear ratio of approximately 2.08:1. The reverse torque multiplication at stall (converter and gear ratios) is approximately 4.57:1.

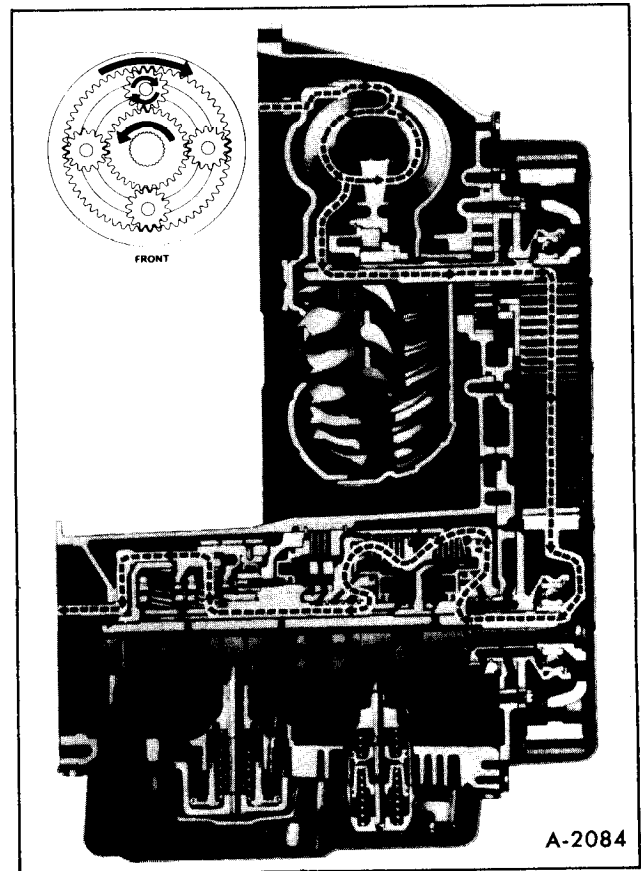

Figure 17–Reverse (Power)

### OIL FLOW (FIGURE 18)

When the selector lever is moved to the Reverse position, the manual valve is positioned to allow line pressure to enter the reverse circuit. Reverse oil then flows to the:

1. Direct Clutch
2. 2-3 Shift Valve
3. Rear Servo Piston
4. Pressure Boost Valve

#### Basic Control

Reverse oil from the manual valve flows to the

large area of the direct clutch piston and to the 2-3 shift valve. From the 2-3 shift valve, it enters the direct clutch passage and is directed to the small area of the direct clutch piston to apply direct clutch.

Reverse oil flows to the rear servo and acts on the servo piston to apply the rear band. Reverse oil also acts on the pressure boost valve to boost line pressure.

#### Summary

The direct clutch and the rear band are applied. The transmission is in Reverse.

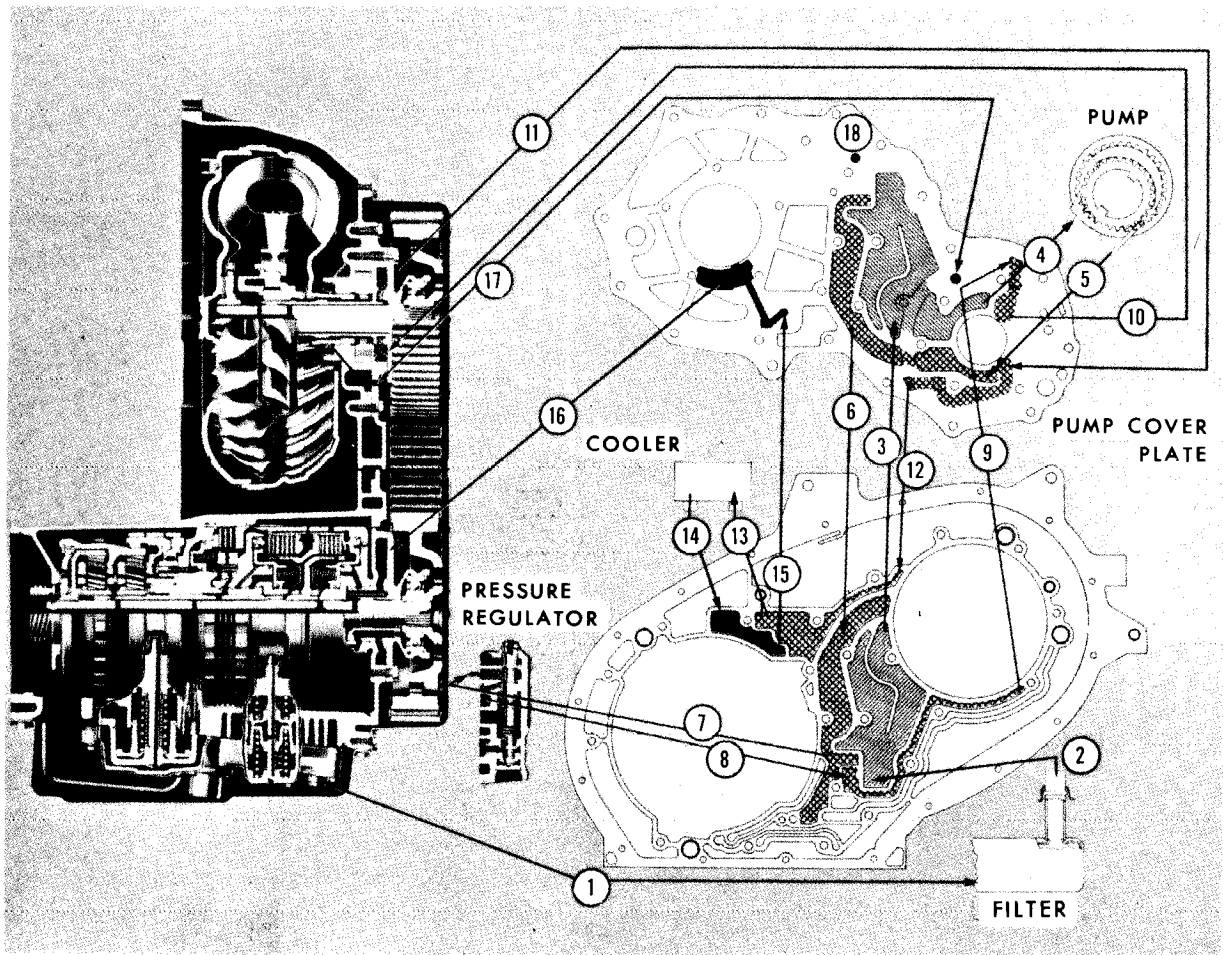

- 1 OIL FROM SUMP TO FILTER
- 2 FILTER TO CASE PASSAGE
- 3 CASE PASSAGE TO PUMP COVER PLATE PASSAGE
- 4 PUMP COVER PLATE PASSAGE TO PUMP
- 5 PUMP TO PUMP COVER PLATE PASSAGE
- 6 PUMP COVER PLATE PASSAGE TO CASE PASSAGE
- 7 CASE PASSAGE TO PRESSURE REGULATOR VALVE
- 8 PRESSURE REGULATOR VALVE TO CASE PASSAGE
- 9 CASE PASSAGE TO PUMP COVER PLATE PASSAGE
- 10 PUMP COVER PLATE PASSAGE TO CONVERTER
- 11 CONVERTER TO PUMP COVER PLATE PASSAGE
- 12 PUMP COVER PLATE PASSAGE TO CASE PASSAGE

- 13 CASE PASSAGE TO COOLER
  - 14 COOLER RETURN TO CASE PASSAGE
  - 15 CASE PASSAGE TO PUMP COVER PLATE PASSAGE
  - 16 PUMP COVER PLATE PASSAGE TO TRANSMISSION POWER TRAIN (ALL INTERNAL LUBRICATION)
- NOTE: THE NUMBERS IN THE CROSS SECTION INDICATE THAT THERE ARE ADDITIONAL LUBRICATION HOLES IN THIS AREA THAT ARE NOT SHOWN IN THE CROSS SECTION
- 17 FRONT SEAL DRAIN BACK HOLE
  - 18 PRESSURE REGULATOR VENT HOLE

A-2085

Figure 19—Lubrication Chart



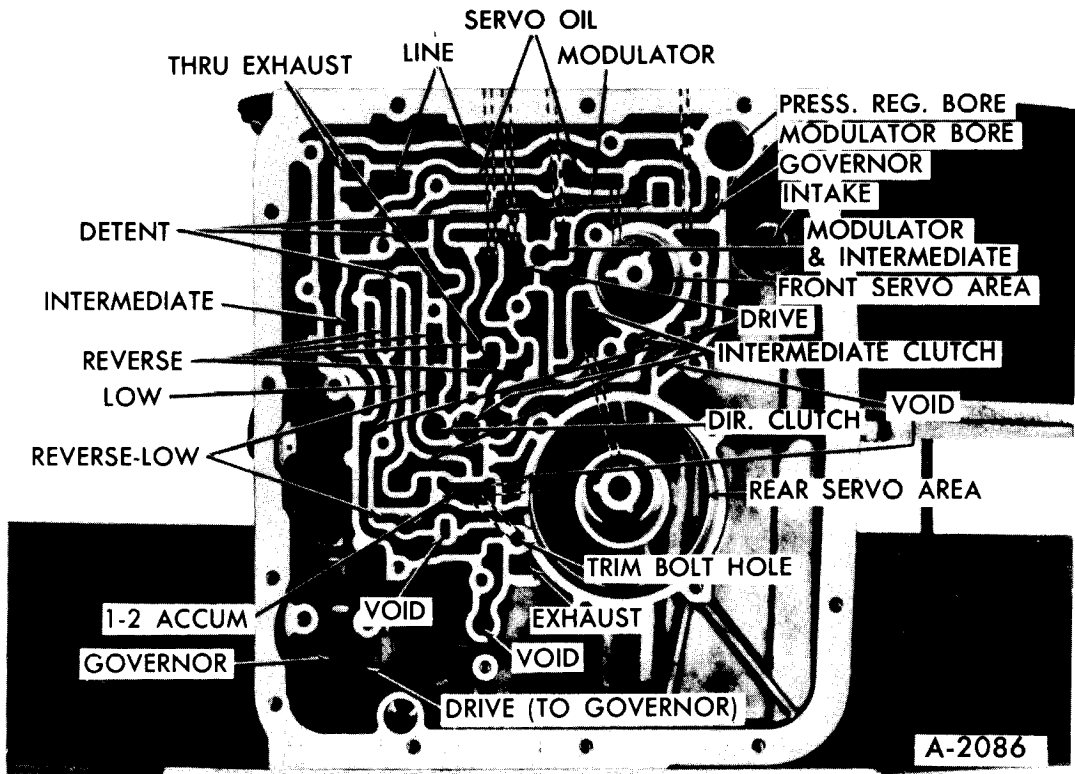

Figure 20-Case Oil Passages-Front & Bottom

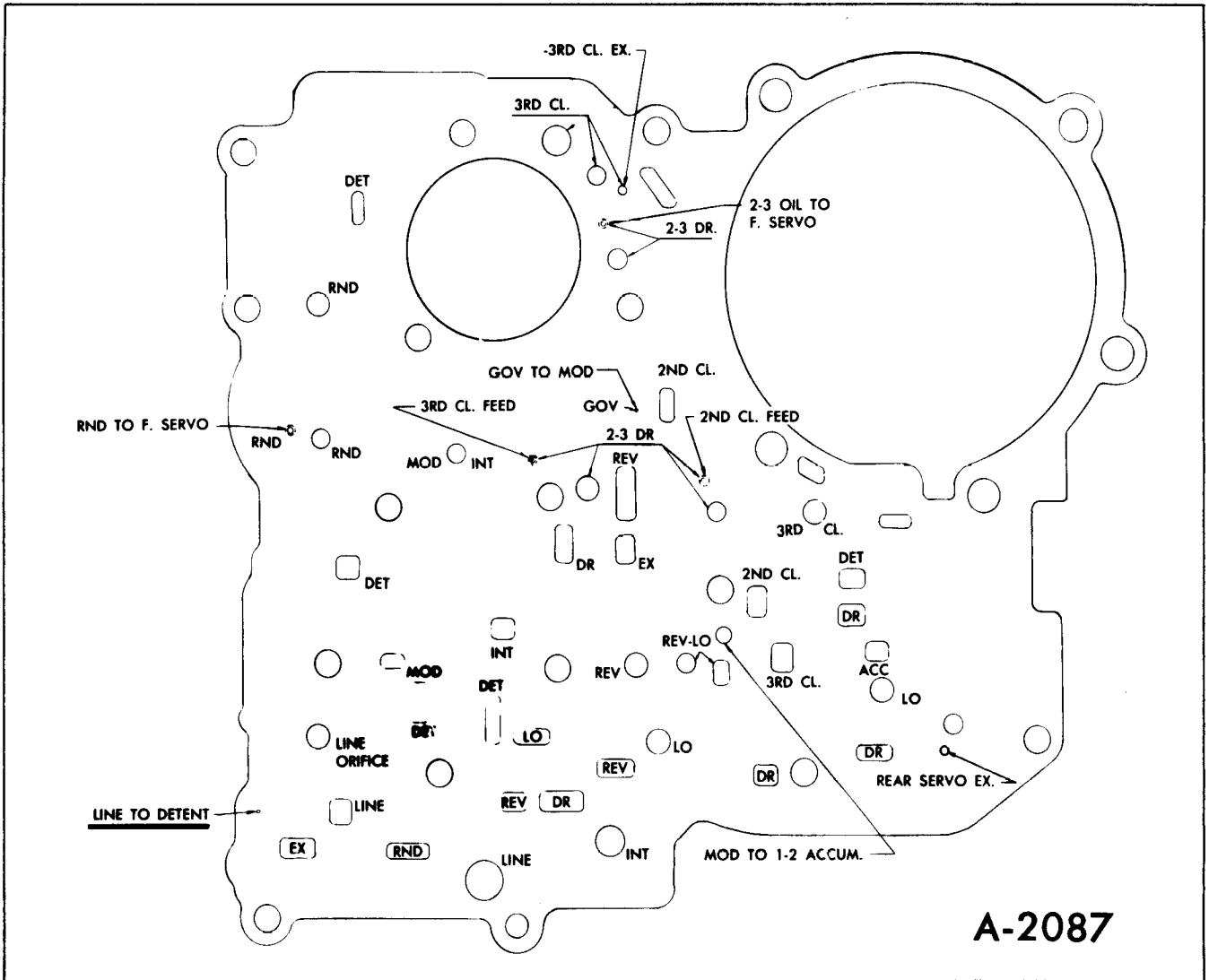

Figure 21—Spacer for Control Valve Assembly

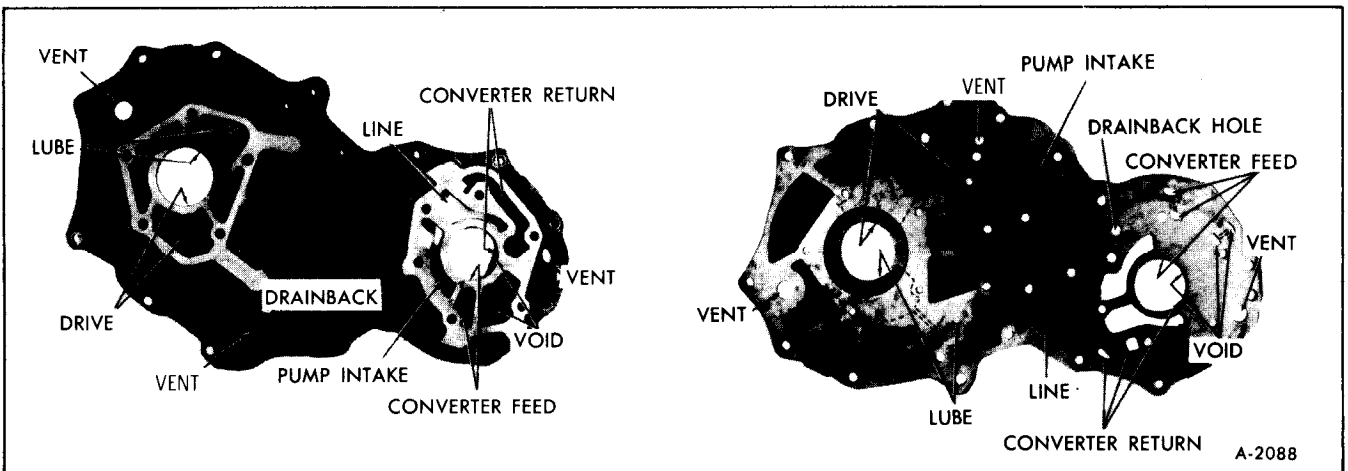
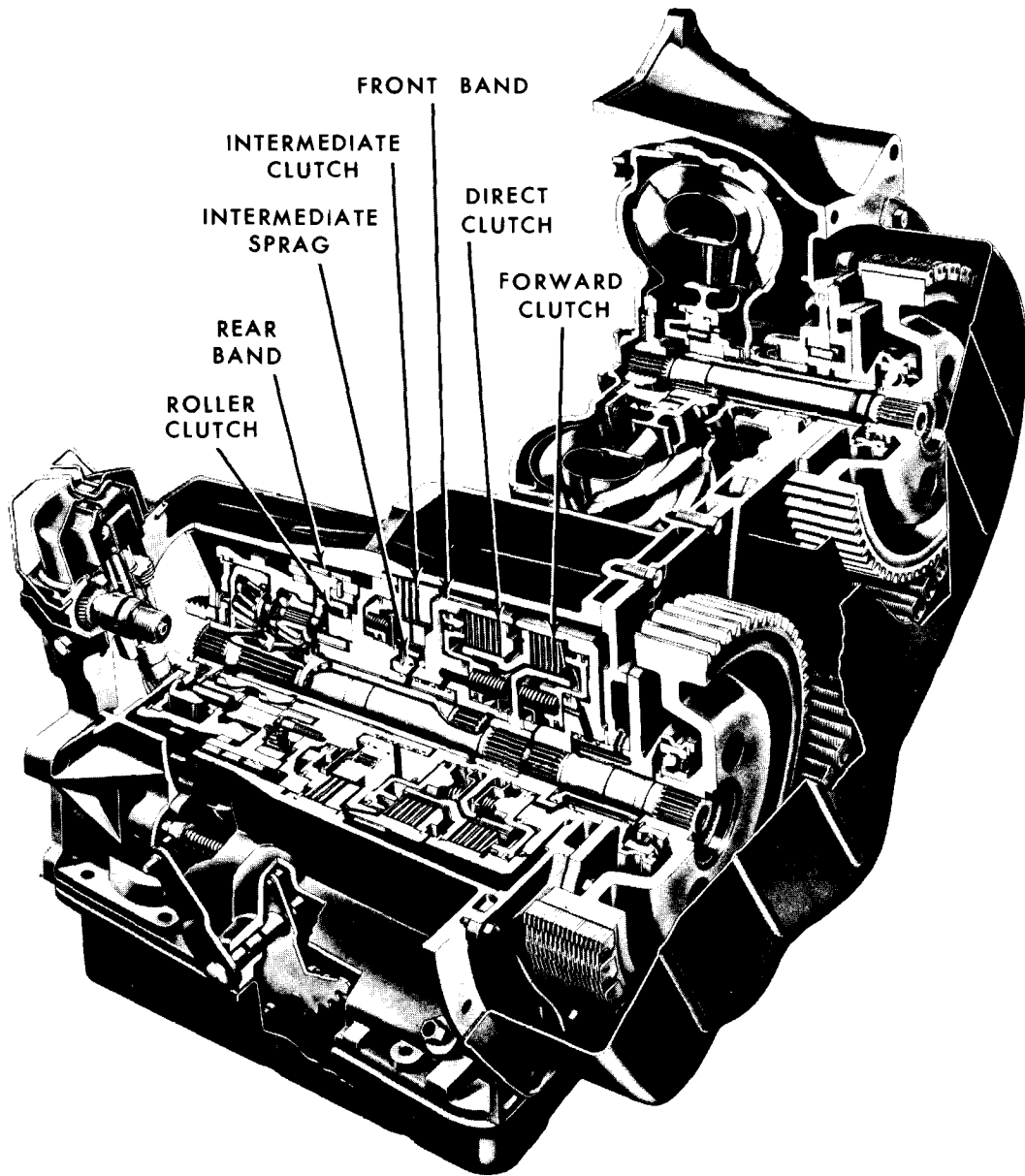

Figure 22—Pump Cover Oil Passages



A-2089

SELECTOR POSITION	PUMP PRESSURE	FORWARD CLUTCH	DIRECT CLUTCH	FRONT BAND	INT. CLUTCH	INT. SPRAG	ROLLER CLUTCH	REAR BAND
PARK-NEUT.	60-150	OFF	OFF	OFF	OFF	OFF	OFF	OFF
DRIVE 1	60-150	ON	OFF	OFF	OFF	OFF	ON	OFF
LEFT 2	60-150	ON	OFF	OFF	ON	ON	OFF	OFF
3	60-150	ON	ON	OFF	ON	OFF	OFF	OFF
DRIVE 1	150	ON	OFF	OFF	OFF	OFF	ON	OFF
RIGHT 2	150	ON	OFF	ON	ON	ON	OFF	OFF
LO 1	150	ON	OFF	OFF	OFF	OFF	ON	ON
2	150	ON	OFF	ON	ON	ON	OFF	OFF
REV.	95 - 230	OFF	ON	OFF	OFF	OFF	OFF	ON

Figure 23-Clutch, Band, and Sprag Application

# TROUBLE DIAGNOSIS

## FLUID LEAKAGE PRECAUTIONS

The precautions that must be observed to prevent fluid leaks are as follows:

1. Use new gaskets and O-ring seals whenever there is a disassembly.
2. Use a very small amount of petrolatum to hold gaskets and thrust washers in place during assembly, or to seal gaskets. Never use gasket paste or shellac.
3. Make sure that composition cork and paper gaskets are not wrinkled or creased when installed. Make sure that gaskets have not stretched or shrunk during storage.
4. Make sure the square type O-ring seals are installed squarely and are not twisted during assembly.
5. Make sure that mating surfaces of castings are flat and smooth, free of deep scratches, chips, and burrs.
6. Torque bolts to proper torque.

## POINTS OF POSSIBLE OIL LEAKS

When checking for oil leaks, first determine whether leak originates from transmission or engine. The original factory fill fluid in the transmission is formulated with a red aniline dye to assist in locating leaks. However, the fluid color will change after a short time in service. Red dye appearing in the leaking oil will give positive identification as to the location of the leak.

If oil leak is found to be in transmission, check for leak in following areas:

### REAR END

It will be necessary to remove converter cover to determine location of leaks at rear end. To correct leaks at rear end, it will be necessary to remove transmission from vehicle.

1. Pump oil seal leak – Check pump oil seal to make certain it is correctly installed and not damaged.

When installing a new pump oil seal, make certain that bore is free from foreign material and that garter spring on seal is correctly positioned. Check finish of converter neck and bearing surface in pump body.

2. Pump assembly-to-case O-ring damaged.
3. Converter – Inspect converter for indications of leakage.
4. Vent fitting damaged.

## COVER AND PLATE ASSEMBLY SPROCKET HOUSING LEAK

1. Attaching bolts not correctly torqued.
2. Housing to case gasket improperly installed or damaged.
3. Housing to case gasket face not flat.

## FINAL DRIVE TO TRANSMISSION LEAK

1. Attaching bolts not correctly torqued.
2. Final drive to transmission gasket improperly installed or damaged.
3. Mounting surfaces not flat.

## TRANSMISSION CASE

1. Speedometer driven gear housing retainer attaching screw loose. Tighten to 18 foot-pounds.
2. Speedometer driven gear housing O-ring or lip seal damaged.
3. Governor cover bale-type attaching retainer not tight.
4. Damaged governor O-ring.
5. Solenoid connector terminal O-ring damaged.
6. Manual shaft O-ring damaged.

7. Vacuum modulator damaged.

8. Vacuum modulator retainer screw loose. Tighten to 18 foot-pounds.

9. Vacuum modulator diaphragm damaged, (not an external oil leak).

**NOTE:** A ruptured diaphragm would allow transmission oil to be drawn into intake manifold and vacuum line. Usually the exhaust will be excessively smoky due to transmission oil added to the combustion. Oil level of transmission will also be low.

10. Bottom pan gasket damaged.

11. Bottom pan attaching screws loose. Tighten to 12 foot-pounds.

12. Line pressure plug not tight. Tighten to 10 foot-pounds.

13. Porous or cracked casting.

14. Vent pipe.

a. Transmission over-filled.

b. Water in oil.

c. Pump to case gasket mispositioned.

d. Foreign material between pump and case, or between pump cover and body.

e. Case – Porous, pump face improperly machined.

f. Pump – Shy of stock, porous.

## OIL COOLER PIPE CONNECTIONS

1. Outside oil cooler pipe connections improperly installed or damaged. Also connectors in radiator and transmission.

2. Oil cooler pipe connections not tight. Tighten to 20 foot-pounds.

3. Flare on oil cooler pipes damaged at radiator or transmission.

## FILLER PIPE

1. O-ring damaged or improperly installed on pipe.

2. Filler Pipe not fully seated in case.

## INTERNAL LEAKS

It will be necessary to remove bottom pan to determine location of internal leaks.

1. Governor pipes damaged.

2. Control valve assembly-to-spacer or case gaskets damaged.

3. Control valve assembly attaching screws loose. Tighten to 8 foot-pounds.

4. Solenoid gaskets damaged.

5. Solenoid attaching screws loose. Tighten to 8 foot-pounds.

6. Intake pipe O-ring damaged.

7. Rear servo square cut O-ring improperly installed or damaged.

## FUNCTIONAL DIAGNOSIS PROCEDURE

### ROAD TEST

Check All Shifts In The Following Manner:

### DRIVE RANGE:

Position selector lever in **DRIVE RANGE** and accelerate the vehicle from 0 mph. A 1-2 and 2-3 shift should occur at all throttle openings. (The shift points will vary with the throttle opening). As the vehicle decreases in speed to 0 mph, the 3-2 and 2-1 shifts should occur.

### SUPER RANGE:

Position the selector lever in **SUPER RANGE** and accelerate the vehicle from 0 mph. A 1-2 shift should occur at all throttle openings. (No 2-3 shift can be obtained in this range). The 1-2 shift point will vary with throttle opening. As the vehicle decreases in speed to 0 mph, a 2-1 shift should occur. **NOTE:** The 1-2 shift in **SUPER RANGE** is somewhat firmer than in **DRIVE RANGE**. This is normal.

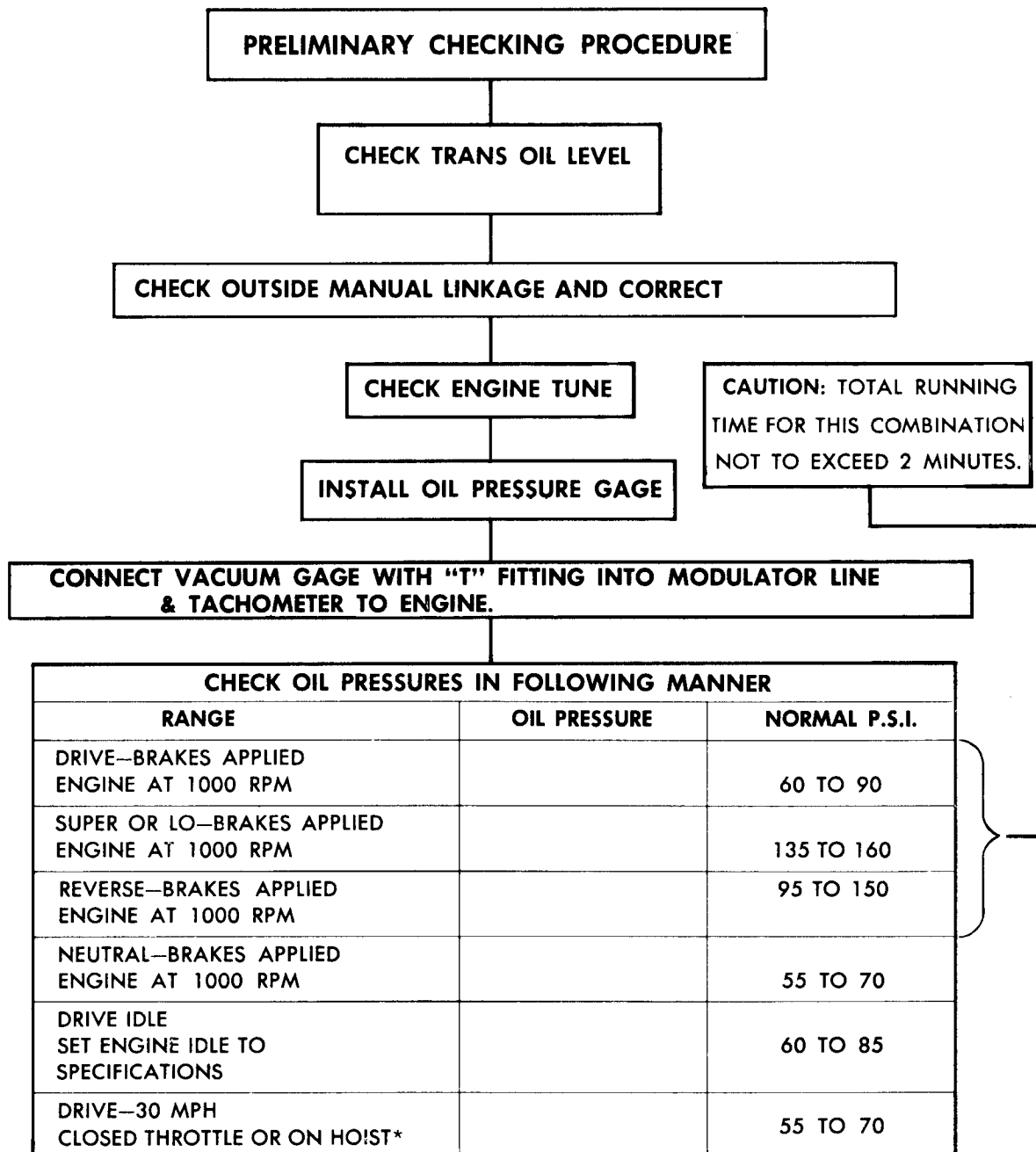

\*THE DRIVE—30 MPH CLOSED THROTTLE PRESSURE READING MAY BE TAKEN DURING A ROAD TEST OR:

1. VEHICLE ON HOIST—DRIVING WHEELS OFF GROUND, FOOT OFF BRAKE, IN DRIVE RANGE.
2. Engine 2000 RPM.
3. CLOSE THROTTLE (FOOT OFF ACCELERATOR) AND TAKE PRESSURE READING ENGINE 2000-1200 RPM.

**NOTE:** WITH CLOSED THROTTLE AND DRIVING WHEELS OFF THE GROUND, ENGINE RPM WILL DROP RAPIDLY. PRESSURE READING MUST BE TAKEN WITHIN RPM'S INDICATED AND WITH CLOSED THROTTLE.

**TRANSMISSION MALFUNCTION RELATED TO OIL PRESSURE**  
**(PRESSURES OBTAINED BY THE PRELIMINARY CHECKING PROCEDURE)**

MALFUNCTION	DRIVE BRAKES APPLIED 1000 RPM	REVERSE BRAKES APPLIED 1000 RPM	SUPER OR LO BRAKES APPLIED 1000 RPM	NEUTRAL BRAKES APPLIED 1000 RPM	DRIVE 30 MPH CLOSED THROTTLE	DRIVE IDLE	PRESSURE DROP OCCURS WHILE ENGINE RPM INCREASES FROM 1000 TO 3000 RPM WHEELS FREE TO MOVE*	POSSIBLE CAUSE OF MALFUNCTION
	OIL PRESSURE	OIL PRESSURE	OIL PRESSURE	OIL PRESSURE	OIL PRESSURE	OIL PRESSURE		
NO 1-2 UPSHIFT AND/OR DELAYED UPSHIFT	NORMAL	NORMAL	NORMAL	NORMAL	NORMAL	NORMAL	DROP	MALFUNCTION IN CONTROL VALVE ASSY.
	NORMAL	NORMAL	NORMAL	NORMAL	NORMAL	NORMAL	NO DROP	MALFUNCTION IN GOVERNOR OR GOVERNOR FEED SYSTEM
	HIGH	NORMAL	NORMAL	NORMAL	HIGH	—	—	MALFUNCTION IN DETENT SYSTEM
	HIGH	HIGH	NORMAL	HIGH	—	—	—	MALFUNCTION IN MODULATOR OR VACUUM FEED SYSTEM TO MODULATOR
SLIPPING—REVERSE	NORMAL	LOW	NORMAL	NORMAL	NORMAL	—	—	OIL LEAK IN FEED SYSTEM TO THE DIRECT CLUTCH
SLIPPING—1ST GEAR	LOW	NORMAL	LOW TO NORMAL	NORMAL	LOW TO NORMAL	—	—	OIL LEAK IN FEED SYSTEM TO THE FORWARD CLUTCH

\* DRIVE RANGE, VACUUM LINE DISCONNECTED TO MODULATOR

**NO 1-2 UPSHIFT AND/OR DELAYED UPSHIFT  
OR 1-2 & 2-3 UPSHIFT—FULL THROTTLE ONLY**

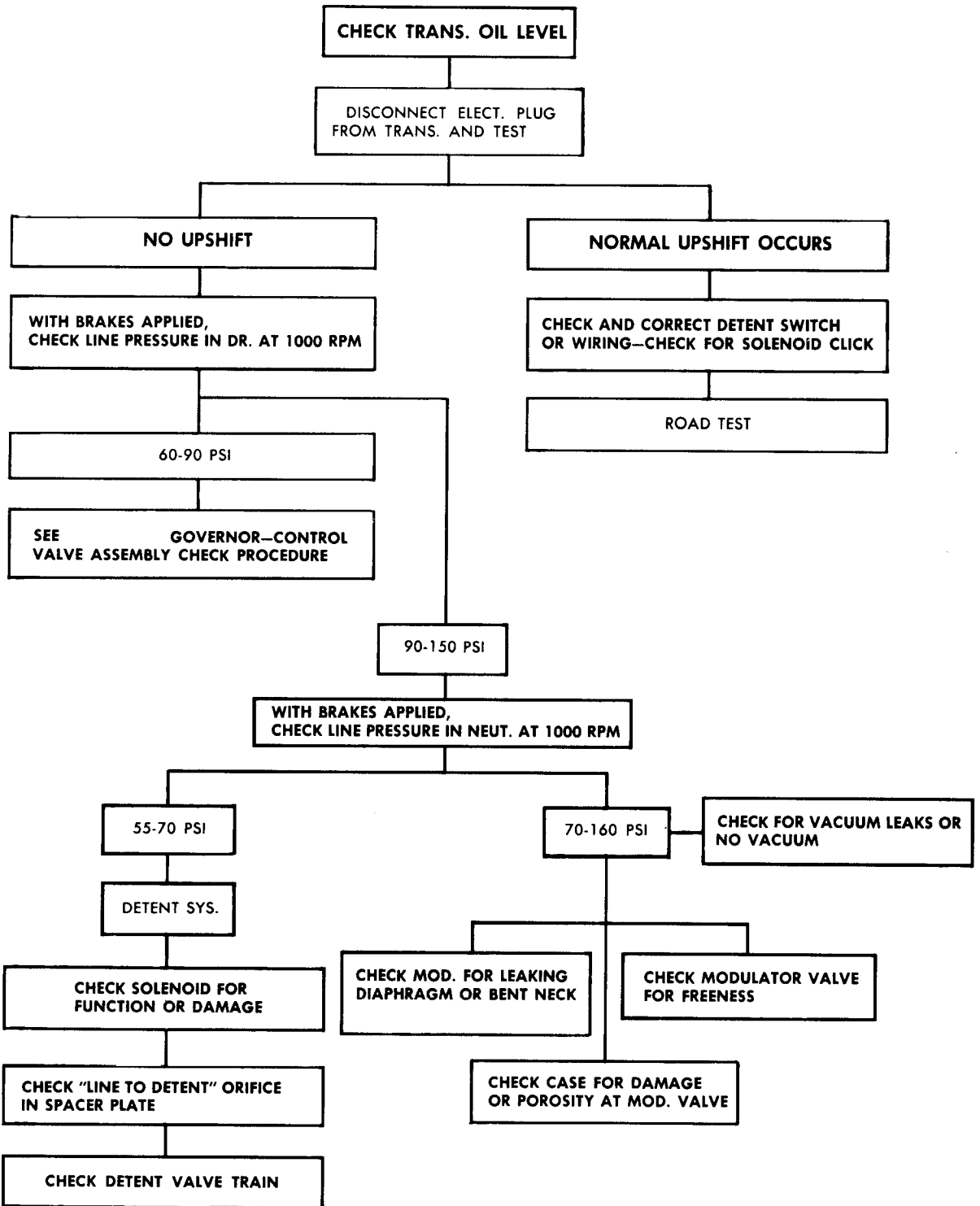



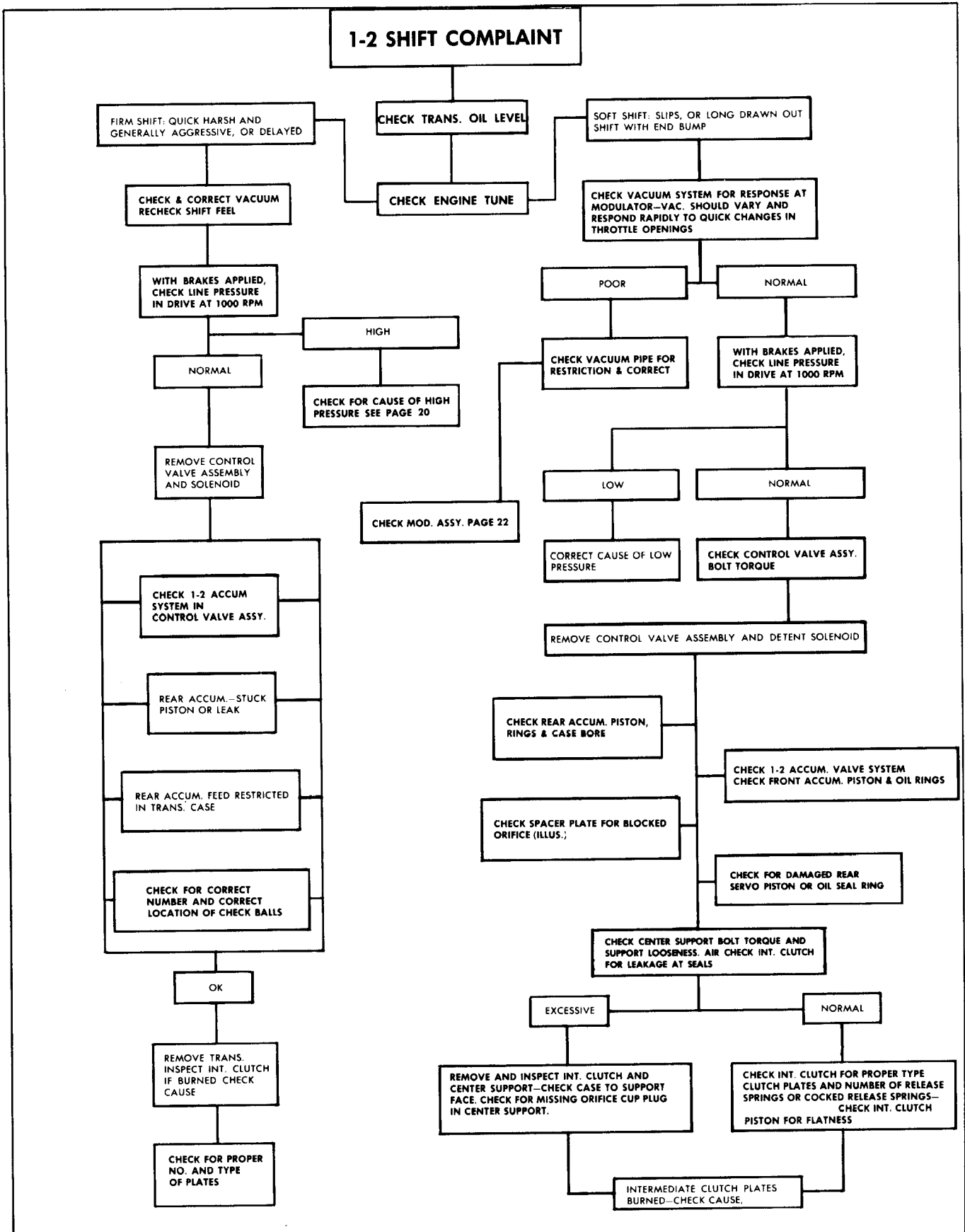

1-2 Shift Complaint

## 2-3 SHIFT COMPLAINT

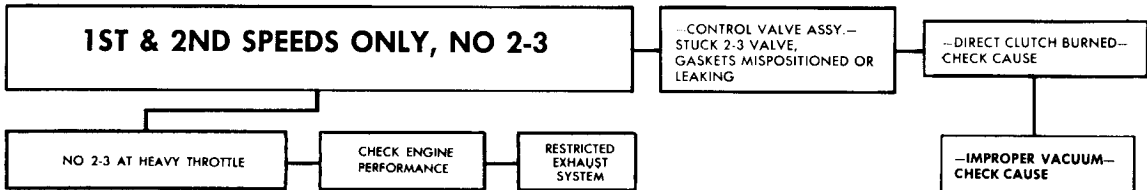
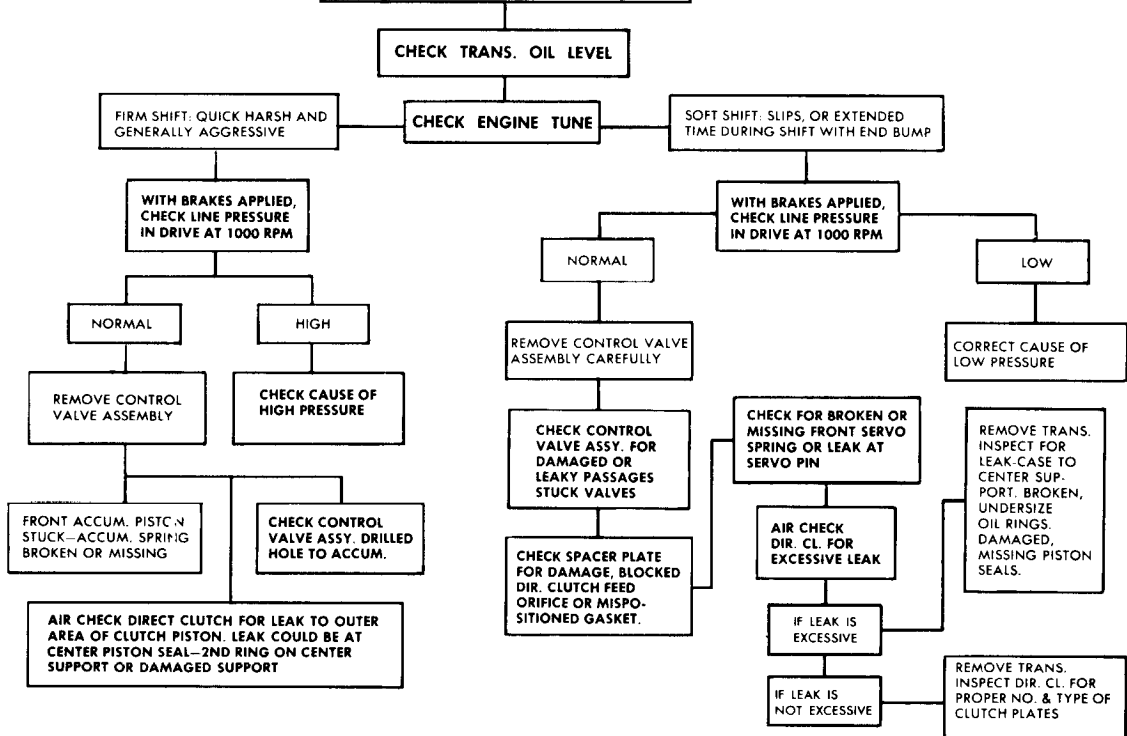

## NO DETENT DOWNSHIFTS

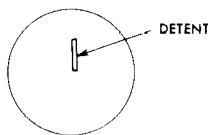
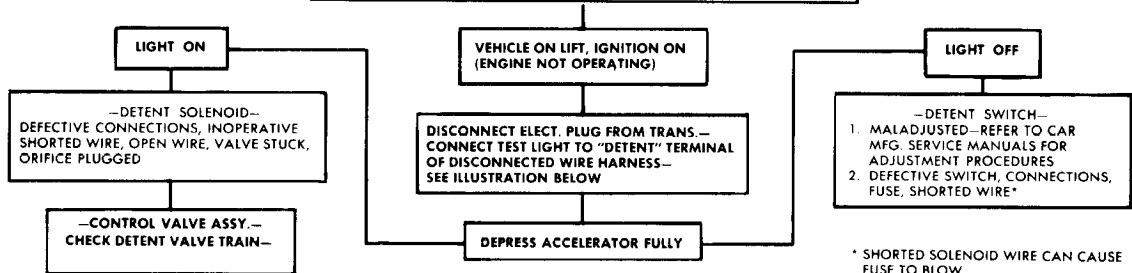

PLUG USED ON FIXED STATOR TRANS.

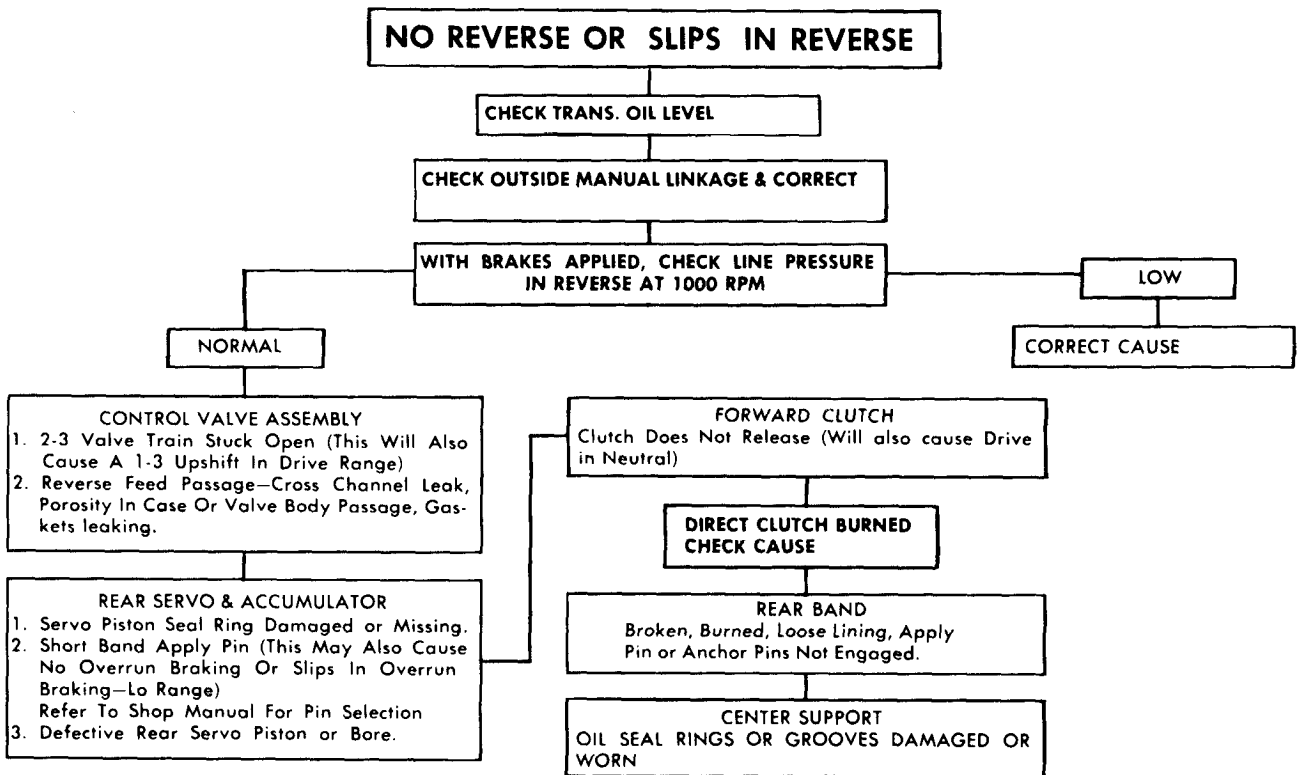
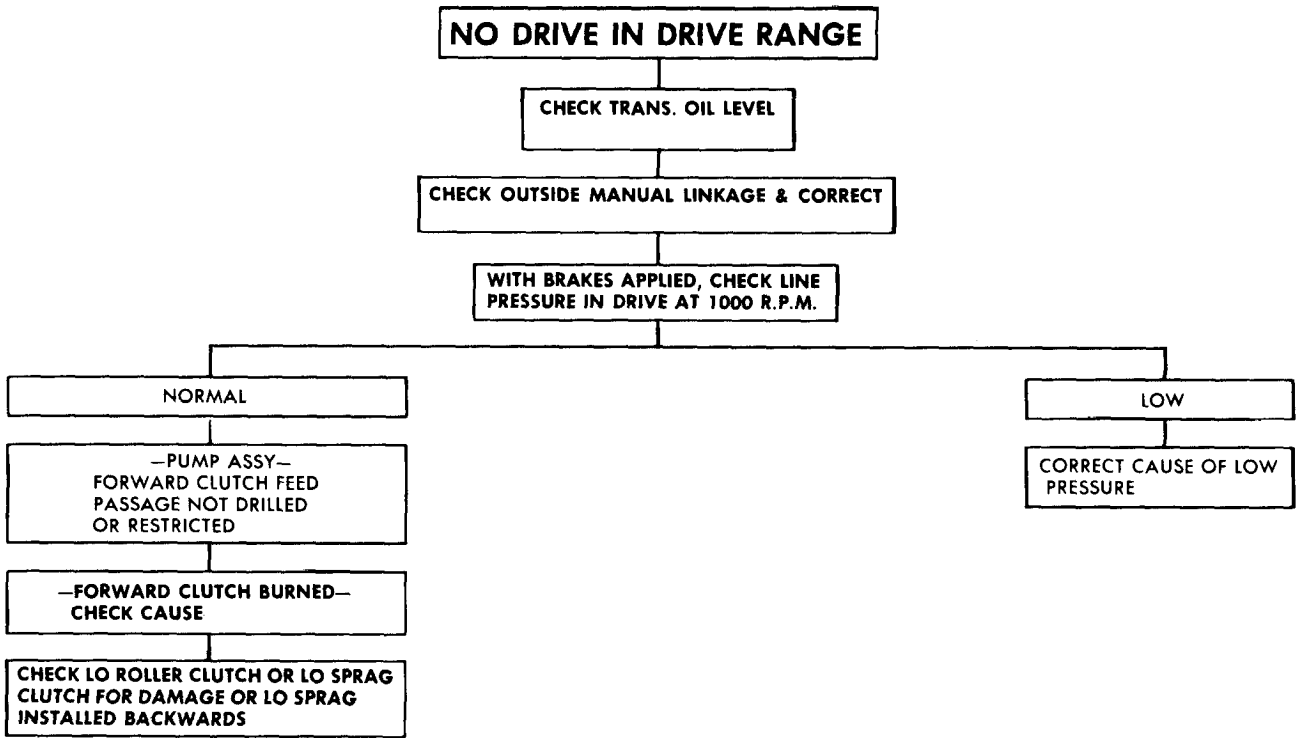

No Drive, No Reverse

**NO ENGINE BRAKING—INTERMEDIATE RANGE—SECOND GEAR**

—FRONT SERVO & ACCUMULATOR—  
OIL RINGS AND/OR BORES LEAKING OR  
FRONT SERVO PISTON COCKED OR STUCK

INCORRECT COMBINATION OF FRONT  
SERVO AND ACCUMULATOR PARTS.

—FRONT BAND—  
BROKEN, BURNED (CHECK FOR CAUSE), NOT  
ENGAGED ON ANCHOR PIN AND/OR  
SERVO PIN.

**DRIVE IN NEUTRAL**

**CHECK OUTSIDE MANUAL LINKAGE & CORRECT**

—INTERNAL LINKAGE—  
MANUAL VALVE DISCONNECTED OR END  
BROKEN, INSIDE DETENT LEVER PIN BROKEN.

—PUMP ASSEMBLY—  
TRANS. LUBE PRESSURE LEAKING INTO  
FORWARD CLUTCH APPLY PASSAGE.

—FORWARD CLUTCH—  
BURNED PLATES—CHECK CAUSE  
INCORRECT CLUTCH PLATE USAGE

**NO ENGINE BRAKING— LO RANGE— 1ST GEAR**

—CASE ASSEMBLY—  
LO—REVERSE CHECK BALL MISPOSITIONED OR  
MISSING. CASE DAMAGED AT LO—REVERSE  
CHECK BALL AREA.

—REAR SERVO—  
OIL SEAL RING, BORE OR PISTON DAMAGED  
REAR BAND APPLY PIN SHORT,  
IMPROPERLY ASSEMBLED

—REAR BAND—  
BROKEN, BURNED (CHECK FOR CAUSE), NOT  
ENGAGED ON ANCHOR PINS AND/OR  
SERVO PIN.

**WON'T HOLD IN PARK OR WON'T  
RELEASE FROM PARK**

**CHECK OUTSIDE MANUAL LINKAGE & CORRECT**

—INTERNAL LINKAGE—

1. Parking Brake Rod Assy. (Check Actuator For Chamfer)
2. Parking Pawl Broken, Chamfer Omitted.
3. Parking Brake Bracket Loose, Burr Or Rough Edges, or Incorrectly Installed.
4. Parking Pawl Return Spring Missing, Broken or Incorrectly Hooked.

**CAUTION:** BEFORE CHECKING TRANSMISSION FOR WHAT IS BELIEVED TO BE "TRANS. NOISE," MAKE CERTAIN THE NOISE IS NOT FROM THE WATER PUMP, ALTERNATOR, AIR CONDITIONER, POWER STEERING, ETC. THESE COMPONENTS CAN BE ISOLATED BY REMOVING THE PROPER BELT AND RUNNING THE ENGINE NOT MORE THAN TWO MINUTES AT ONE TIME.

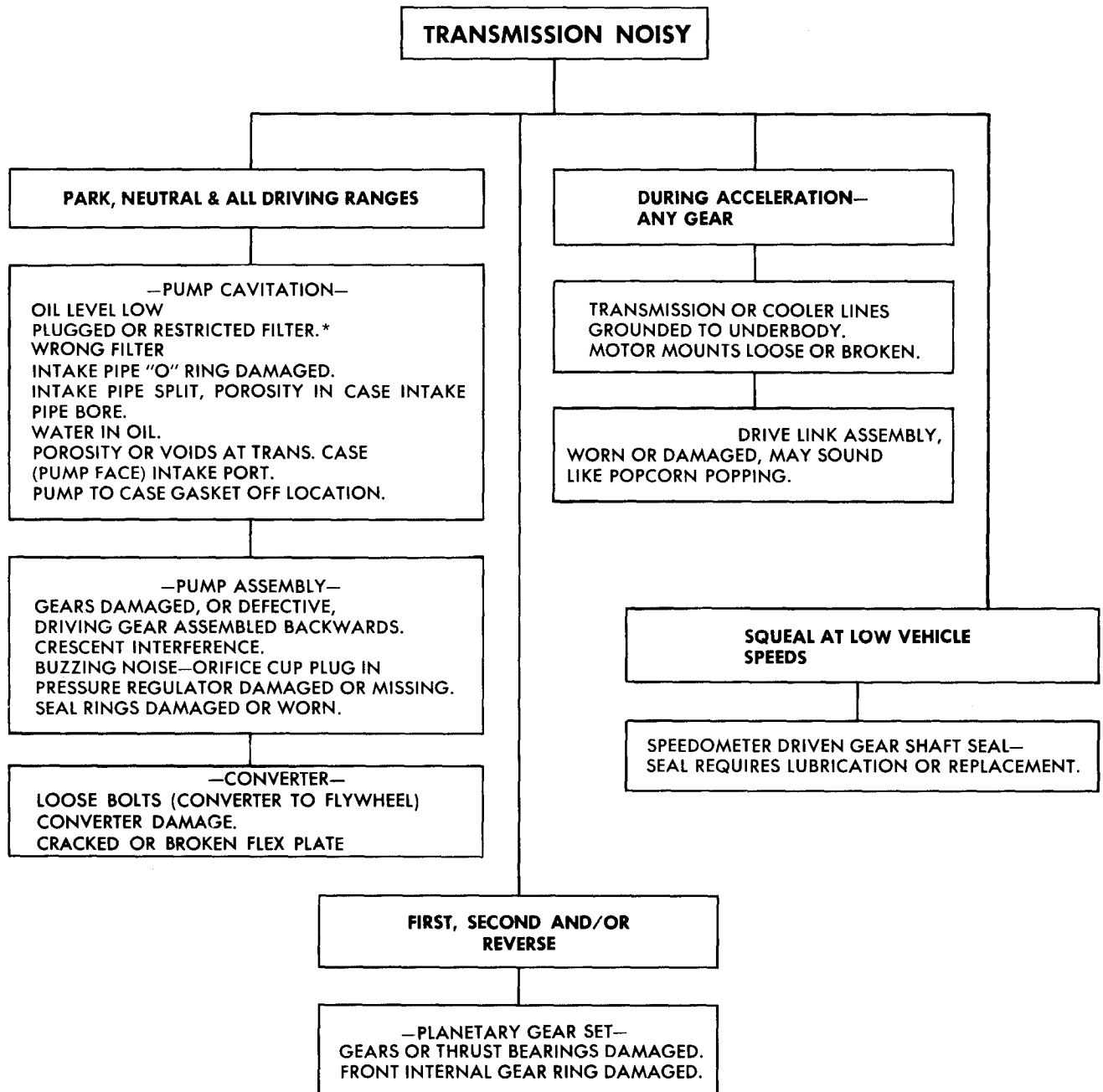

\* There is no approved way of checking or cleaning the filter. If the filter is suspected of being plugged or restricted, it must be replaced.

**LO RANGE:**

Position the selector lever in **LO RANGE** and accelerate the vehicle from 0 mph. No upshift should occur in this range, except in some vehicles which have a high numerical axle ratio and/or high engine rpm.

**2ND GEAR - OVERRUN BRAKING:**

Position the selector lever in **DRIVE RANGE**, and with the vehicle speed at approximately 35 mph, move the selector lever to **SUPER RANGE**. The transmission should downshift to 2nd. An increase in engine rpm and an engine braking effect should be noticed. Line pressure should change from approximately 70 psi to approximately 150 psi in 2nd.

**1st GEAR - OVERRUN BRAKING:**

Position the selector lever in **SUPER RANGE** at approximately 30 to 40 mph, with throttle closed, move the selector lever to **Lo**. A 2-1 downshift should occur in the speed range of approximately 40 to 20 mph, depending on axle ratio and valve body calibration. The 2-1 downshift at closed throttle will be accompanied by increased engine rpm and an engine braking effect should be noticed. Line pressure should be approximately 150 psi. Stop vehicle.

**REVERSE RANGE:**

Position the selector lever in **REVERSE POSITION** and check for reverse operation.

**CAUSES OF LOW LINE PRESSURE**

1. Low Transmission Oil Level.
2. Modulator Assembly
3. Filter.
  - a. Blocked or restricted.\*
  - b. "O" Ring on intake pipe and/or grommet omitted or damaged.
  - c. Split or leaking intake pipe.

d. Wrong filter assembly.

## 4. Pump.

a. Pressure regulator or boost valve stuck.

b. Gear clearance, damaged worn. (Pump will become damaged if drive gear is installed backwards, or if converter pilot does not enter crankshaft freely).

c. Pressure regulator spring, too weak.

d. Not enough spacers in pressure regulator.

e. Pump to case gasket mispositioned.

f. Defective pump body and/or cover.

g. Mismatch pump cover/pump body.

## 5. Internal Circuit Leaks.

a. Forward clutch leak (pressure normal in neutral and reverse-pressure low in drive).

1. Check pump rings.

2. Check forward clutch seals.

b. Direct clutch leak (pressure normal in neutral, low, intermediate, and drive-pressure low in reverse).

1. Check center support oil seal rings.

2. Check direct clutch outer seal for damage.

3. Check rear servo and front accumulator pistons and rings for damage or missing.

## 6. Case Assembly.

a. Porosity in intake bore area.

b. Check case for intermediate clutch plug leak or blown out.

c. Lo-reverse check ball mispositioned or missing (this will cause no reverse and no overrun braking in Lo range).

\*There is no approved service procedure for checking or cleaning the filter. If the filter is suspected of being plugged or restricted, it must be replaced.

**CAUSES OF HIGH LINE PRESSURE**

1. Vacuum Leak.

- a. Full leak (vacuum line disconnected).
- b. Partial leak in line from engine modulator.
- c. Improper engine vacuum.
- d. Vacuum operated accessory leak. (Hoses, vacuum advance, etc.).

## 2. Damaged Modulator.

- a. Stuck valve.
- b. Water in modulator.
- c. Not operating properly.

## 3. Detent System.

- a. Detent switch actuated (plunger stuck) or shorted.
- b. Detent wiring shorted.
- c. Detent solenoid stuck open.
- d. Detent feed orifice in spacer plate blocked.
- e. Detent solenoid loose.
- f. Detent valve bore plug damaged.
- g. Detent regulator valve pin short.

## 4. Pump.

- a. Pressure regulator and/or boost valve stuck.
- b. Incorrect pressure regulator spring.
- c. Too many pressure regulator valve spacers.
- d. Pump casting bad.
- e. Pressure boost valve installed backwards or defective.
- f. Aluminium bore plug has hole or otherwise defective.
- g. Pressure boost bushing broken or otherwise defective.

## 5. Control Valve Assembly.

- a. Spacer plate-to-case gasket off location.
- b. Wrong spacer plate-to-case gasket.

## CAUSES OF IMPROPER VACUUM AT MODULATOR

### 1. Engine.

a. Requires tune up.

b. Loose vacuum fittings.

c. Vacuum operated accessory leak (hoses, vacuum advance, etc.)

### 2. Vacuum Line to Modulator.

a. Leak.

b. Loose fitting.

c. Restricted orifice, or incorrect orifice size.

d. Carbon build up at modulator vacuum fitting.

e. Pinched line.

f. Grease or varnish material in pipe (no or delayed up-shift-cold).

## CONTROL VALVE ASSEMBLY- GOVERNOR LINE PRESSURE CHECK

1. Install line pressure gage.

2. Disconnect vacuum line to modulator.

3. With vehicle on hoist (front wheels off ground), foot off brake, in drive, check line pressure at 1000 rpm.

4. Slowly increase engine rpm to 3000 rpm and determine if a line drop occurs (7 psi or more).

5. If pressure drop occurs, disassemble, clean and inspect control valve assembly.

6. If no pressure drop occurs:

a. Inspect governor.

1. Stuck valve.

2. Weight freeness.

3. Restricted orifice in governor valve.

b. Governor feed system.

1. Check screen in governor feed pipe hole in case assembly.

2. Check for restrictions in governor pipe.

## CAUSES OF BURNED CLUTCH PLATES

**NOTE:** Burned clutch plates can be caused by incorrect usage of clutch plates. Also, anti-freeze in transmission fluid can cause severe damage, such as large pieces of composition clutch material peeling off.

1. Forward Clutch.

a. Check ball in clutch housing damaged, stuck or missing.

b. Clutch piston cracked, seals damaged or missing.

c. Low line pressure.

d. Manual valve mispositioned.

e. Restricted oil feed to forward clutch (Examples: Clutch housing to inner and outer areas not drilled, restricted or porosity in pump).

f. Pump cover oil seal rings missing, broken or undersize; ring groove oversize.

g. Case valve body face not flat or porosity between channels.

h. Manual valve bent and center land not ground properly.

2. Intermediate Clutch.

a. Rear accumulator piston oil ring, damaged or missing.

b. 1-2 accumulator valve stuck in control valve assembly.

c. Intermediate clutch piston seals damaged or missing.

d. Center support bolt loose.

e. Low line pressure.

f. Intermediate clutch plug in case missing.

g. Case valve body face not flat or porosity between channels.

h. Manual valve bent and center land not ground properly.

3. Direct Clutch.

a. Restricted orifice in vacuum line to modulator (poor vacuum response.)

b. Check ball in direct clutch piston damaged, stuck or missing.

c. Defective Modulator bellows.

d. Center support bolt loose. (Bolt may be tight in support but not holding support tight to case).

e. Center support oil rings or grooves damaged or missing.

f. Clutch piston seals damaged or missing.

g. Front and rear servo pistons and seals damaged.

h. Manual valve bent and center land not cleaned up.

i. Case valve body face not flat or porosity between channels.

j. Intermediate roller clutch installed backwards.

k. 3-2 valve, 3-2 spring or 3-2 spacer pin installed in wrong location in 3-2 valve bore.

**NOTE:** If direct clutch plates and front band are burned, check manual linkage.

## VACUUM MODULATOR ASSEMBLY

The following procedure is recommended for checking Turbo Hydra-matic modulator assemblies in the field before replacement is accomplished.

1. Vacuum Diaphragm Leak Check. Insert a pipe cleaner into the vacuum connector pipe as far as possible and check for the presence of transmission oil. If oil is found, replace the modulator.

**CAUTION:** Gasoline or water vapor may settle in the vacuum side of the modulator. If this is found without the presence of oil, the modulator should not be changed.

2. Atmospheric Leak Check. Using Hand Vacuum Pump, such as J-23738, apply 20" HG to



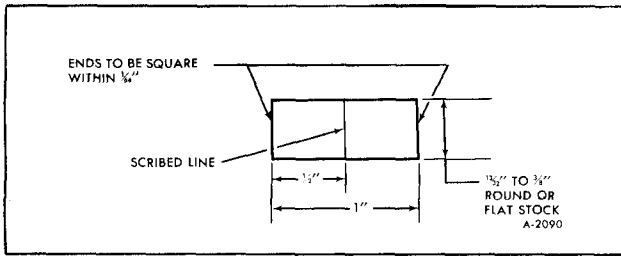

Figure 24—Vacuum Modulator Test Gage

diaphragm. Modulator should hold vacuum for 10 seconds. If vacuum drops, replace modulator.

3. **Bellows Comparison Check.** Make a comparison gage, as shown in Figure 24, and compare the load of a known good Hydra-matic modulator with the assembly in question. Modulator Tension Tester such as J-24466 may also be used for this purpose.

a. Install the modulator that is known to be acceptable on either end of the gage.

b. Install the modulator in question on the opposite end of the gage.

c. Holding the modulators in a horizontal position, bring them together under pressure until either modulator sleeve end just touches the line in the center of the gage. The gap between the opposite modulator sleeve end and the gage line should then be  $1/16$ " or less. If the distance is greater than this amount, the modulator in question should be replaced.

4. **Sleeve Alignment Check.** Roll the main body of the modulator on a flat surface and observe the sleeve for concentricity to the can. If the sleeve is concentric and the plunger is free, the modulator is acceptable.

Once the modulator assembly passes all of the above tests, it is an acceptable part and should be re-used.

## DOWNSHIFT SOLENOID CIRCUIT CHECK

**NOTE:** Before checking the downshift solenoid circuitry, make certain that the transmission downshift switch is properly adjusted.

1. With transmission shift lever in Park, turn ignition switch to "ON" position, but do not start vehicle. Leave ignition switch "ON" throughout checking procedure.

2. With the engine cover removed, slowly ad-

vance throttle linkage to wide open position. One click should be heard from transmission.

3. Allow throttle to return to closed position. One click should be heard from transmission.

4. If system performed as described above, downshift circuit is operating properly. If system does not perform as described above, proceed to step 5.

5. Use test light to check orange wire at connector on side of transmission case. Test light should light with throttle wide open and go out when throttle is released.

a. If system operates as described above, but did not perform properly during steps 1-3, replace solenoid after first checking to see that internal wiring is operational.

b. If light fails to light with throttle in wide open position, the circuit is open, proceed to step 6.

c. If light lights with throttle closed, the circuit is shorted. Proceed to step 9.

6. At transmission downshift switch, use test light to check from the top terminal at switch with throttle wide open.

a. If test light lights, recheck system.

b. If test light fails to light, proceed to step 7.

7. Check lower feed wire at transmission downshift switch with test light.

a. If test light lights, replace transmission downshift switch. Recheck system.

b. If test light fails to light, proceed to step 8.

8. Check 10 amp. (gages and transmission control fuse) in fuse panel.

a. If necessary to replace fuse, recheck system.

b. If fuse is all right, it will be necessary to locate the open in the wiring. Test the circuit continuity from the lower wire at the downshift switch to the battery.

9. At the transmission downshift switch, use test light to check from the disconnected top terminal at switch with throttle closed.

a. If test light fails to light, orange wire is shorted. Correct shorting condition.

b. If test light lights, proceed to step 10.

10. With throttle in closed position, check lower feed wire at transmission downshift switch.

a. If test light fails to light, replace transmission downshift switch. Recheck system.

b. If test light lights, it will be necessary to locate the short in the wiring. Test the circuit from the lower wire at the downshift switch to the battery.

**CLUTCH PARTS**

Clutch	No. of Flat Steel Clutch Plates	No. of Waved Steel Clutch Plates
Forward Clutch.....	5	1
Direct Clutch.....	5	1
Intermediate Clutch.....	3	-

*Clutch Plate Dished*

Clutch	No. of Clutch Composition Plates	No. of Piston Release Springs
Forward Clutch.....	5	16
Direct Clutch.....	6	14
Intermediate Clutch.....	3	6

**ON VEHICLE SERVICING**

**FLUSHING OIL COOLER**

The oil cooler is located in the side tank of the radiator and its purpose is to cool the oil in the event excessive temperature tends to develop. (figure 25)

In a major transmission failure, where particles of metal have been carried with the oil throughout the units of the transmission. It will be necessary to flush out the oil cooler and connecting lines. The oil cooler is a sealed container providing a passage for oil to flow from the inlet to the outlet. Clean solvent can be flushed through the cooler with air pressure. (An engine desludge gun may be used.) The cooler should be back-flushed first through the return line to remove all foreign material possible. Then flush through the inlet line and finish by flushing through the return line. Clean remaining solvent from cooler with compressed air applied to the return line and flush with transmission fluid.

**LINKAGE ADJUSTMENT (FIGURE 26)**

**CAUTION:** *Block vehicle wheels and apply*

*parking brake before attempting transmission linkage adjustment.*

1. Place steering column shift lever in neutral against stop in column, (a detent will hold it there).
2. Loosen relay rod clamp screw.
3. Position range selector lever in the neutral detent position.

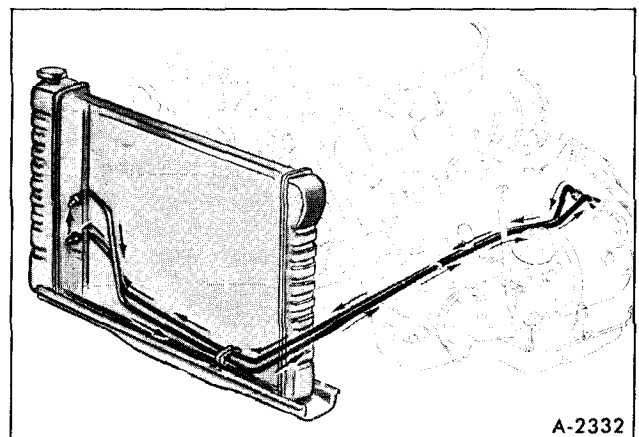

A-2332

Figure 25—Oil Cooler and Lines

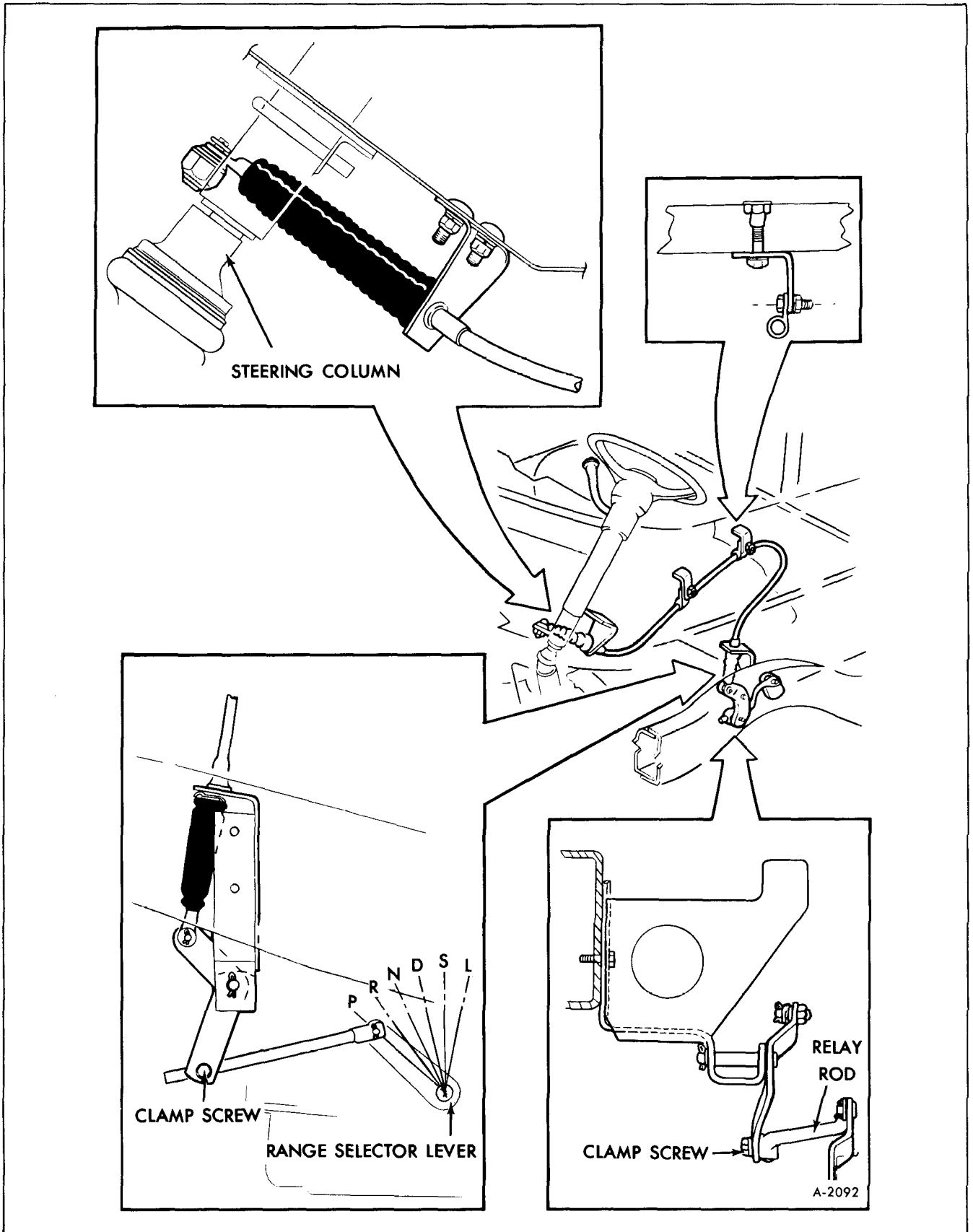

Figure 26-Transmission Manual Linkage

4. Tighten relay rod clamp screw to 20 ft. lbs., making sure shift lever is held against Neutral stop while this operation is being performed.

5. Check operation of selector lever by performing the following steps:

a. Lift lever and move to Neutral detent. (This is the detent in the transmission.) Release the lever and check to make sure that the lever fits into the neutral notch in the steering column.

b. Move lever to Drive detent. There should be a slight travel of the lever beyond this detent until the drive stop in the steering column is reached.

c. Move lever to Reverse detent and check as in b above.

6. Check for proper operation of neutral safety switch and back-up lights, (be sure vehicle has positive "PARK" engagement and "L" range engagement). When parking on a hill, refer to additional details on PARKING BRAKE in Operating Manual.

## DOWNSHIFT SWITCH ADJUSTMENT

The procedure for adjusting the downshift switch is described in SECTION 6M under "Accelerator Control".

## CHECKING AND ADDING FLUID

**NOTE:** Vehicle level and oil temperature are particularly important when checking fluid level on a Turbo Hydra-matic transmission. Careful attention to the following procedures is necessary in order to determine the actual fluid level.

### Oil Recommendations

Whenever fluid is added to the transmission use only DEXRON type transmission fluid, or fluids of equivalent quality that have been especially formulated and tested for use in the Turbo Hydra-matic transmission.

### Oil Level

The transmission dipstick and filler tube is located under the engine access cover at the left center side of the engine. The "FULL" and "ADD" dimple marks on the transmission dipstick indicate one pint difference. Correct fluid level is determined at normal engine coolant operating temperature (180°F-190°F). Careful attention to transmission oil

temperature is necessary, as proper fluid level at low operating temperatures will be below the "ADD" mark on the dipstick, Figure 27, and proper fluid level at higher operating temperatures will rise above the "FULL" mark. Fluid level must always be checked with the vehicle on level surface, and with engine running to make certain converter is full. To determine proper fluid level, proceed as follows:

**NOTE:** The full mark on the dipstick is an indication of transmission fluid at normal operating temperature of 170°. This temperature is only obtained after several miles of stop-and-go driving.

1. With manual control lever in Park position start engine. **DO NOT RACE ENGINE.** Move manual control lever through each range.

2. Immediately check fluid level with selector lever in Park, engine running, and vehicle on LEVEL surface.

At this point, when a reading is made, fluid level on the dipstick should be between the add and full mark.

3. If additional fluid is required, add fluid to raise the level between the add and full mark.

If vehicle is not driven 15 expressway miles or equivalent, and it becomes necessary to check fluid level, the transmission fluid must be at room temperature (approximately 70°F.).

With fluid at room temperature follow steps 1, 2 and 3 below.

1. With manual control lever in Park position start engine. **DO NOT RACE ENGINE.** Move manual control lever through each range.

2. Immediately check fluid level with selector lever in Park, engine running, and vehicle on LEVEL surface.

At this point, when a reading is made, fluid level on the dipstick should be 1/4" below the "ADD" mark.

3. If additional fluid is required add fluid to bring level to 1/4" below the "ADD" mark on the dipstick.

**CAUTION:** Do not overfill, as forming and loss of fluid through the vent pipe might occur as fluid heats up. If fluid is too low, especially when cold, complete loss of drive may result which can cause transmission failure.

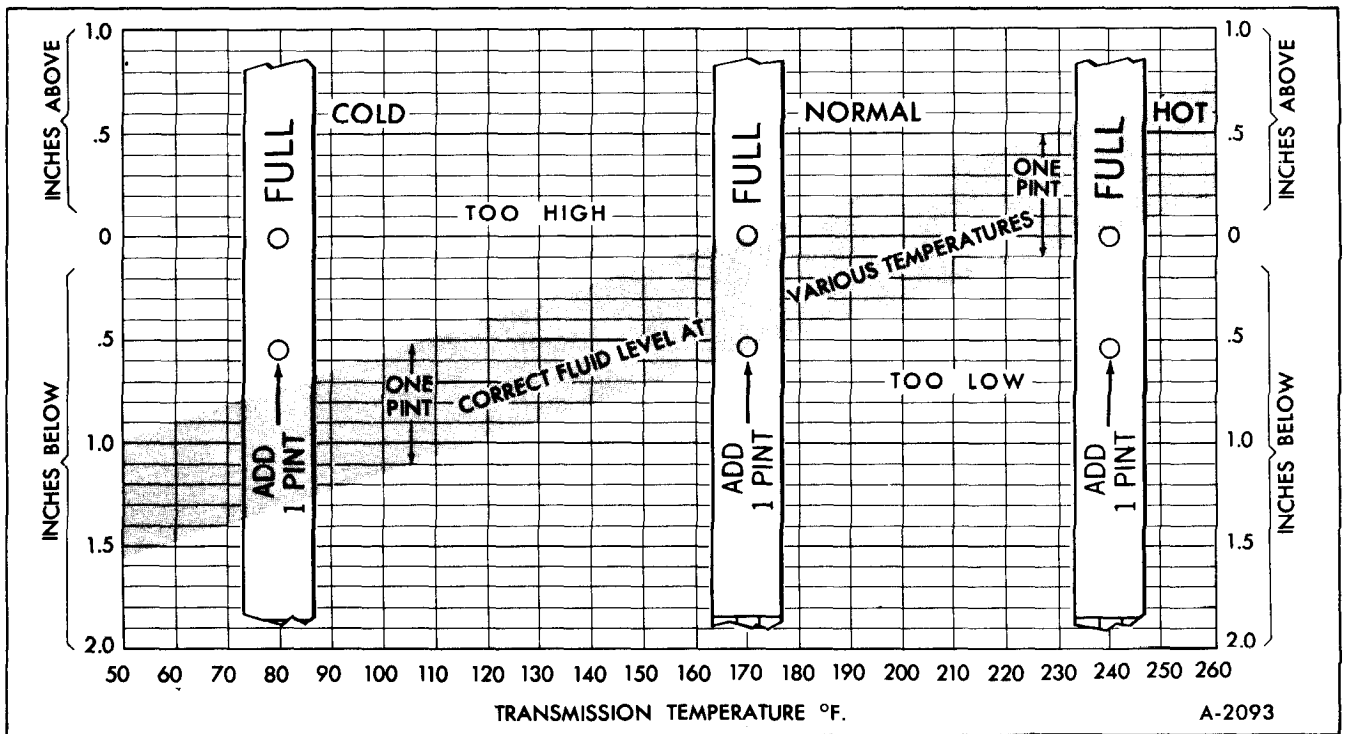

Figure 27—Transmission Oil Level

**NOTE:** If transmission fluid level is correctly established at 70°F. (.9" below full) it will appear at the "FULL" mark on the dipstick when the transmission reaches normal operating temperature (170°F.). When cold the fluid level is set 1/4" below the "ADD" mark on the dipstick to allow for expansion of the fluid which occurs as transmission temperatures rise to normal operating temperature of 170°F.

### Draining Bottom Pan and Replacing Intake Pipe and Filter Assembly

To drain bottom pan only, eliminate steps 5 and 6.

1. Remove dipstick from filler tube and insert a length of hose secured to a suction gun down the dipstick. Remove enough transmission fluid so that bottom pan will not overflow when removed.

2. Raise vehicle on hoist or place on jack stands, and provide container to collect draining oil.

3. Remove bottom pan and gasket. Discard gasket.

4. Drain fluid from bottom pan. Clean pan with solvent and dry thoroughly with clean compressed air.

5. Remove intake pipe and filter assembly. Remove and discard intake pipe O-ring.

6. Install new intake pipe O-ring into pipe bore in transmission case and install new intake pipe and filter assembly.

7. Install new gasket on bottom pan and install bottom pan. Tighten bottom pan attaching screws to 12 foot-pounds.

8. Lower vehicle and add five quarts of transmission fluid through filler tube when replacing intake pipe and filter assembly. When draining bottom pan only, add four quarts of transmission fluid.

9. Operate engine at 800 rpm for approximately 1-1/2 minutes with selector lever in park "P" position.

10. Reduce engine speed to slow idle and check fluid level. Add fluid to bring to proper level, Figure 27.

### Adding Fluid to Dry Transmission and Converter Assembly

The fluid capacity of the Turbo Hydra-matic transmission and converter assembly is approximately 13 quarts, but correct level is determined by

mark on dipstick rather than by amount added. It is important that proper level be maintained. In cases of transmission overhaul, when a complete fill is required, including converter, proceed as follows:

1. Add 9 quarts of transmission fluid through filler tube.
2. Operate engine at 800 rpm for approximately 1-1/2 minutes with selector lever in park "P" position.
3. Reduce engine speed to slow idle.
4. Check fluid level and add additional fluid to bring to proper level, Figure 27.

### **Sprocket Housing Cover Removal**

If the sprocket housing cover is removed, add transmission oil as described under "OIL LEVEL".

## **TOWING INSTRUCTIONS**

Refer to SECTION 0 for towing instructions.

## **UNITS THAT CAN BE REMOVED WITH TRANSMISSION IN VEHICLE**

The following units can be removed from the

transmission without removing transmission from vehicle.

While the detailed procedure for removing each of the units is not outlined separately, the procedures covered under the transmission disassembly and assembly will apply.

1. Oil pan and pan to case gasket.
2. Pressure regulator valve assembly.
3. Valve body assembly.
4. Rear servo and accumulator assembly.
5. Front servo and accumulator assembly.
6. Governor pipes.
7. Detent solenoid.
8. Solenoid connector.
9. Parking linkage.
10. Valve body to case spacers and gaskets.
11. Check balls.
12. Detent roller and spring assembly.
13. Filter assembly.

## **TRANSMISSION REPLACEMENT**

### **REMOVAL OF TRANSMISSION**

Due to the power train configuration, it is easier to remove the transmission and final drive as an assembly. The following is the procedure to remove the transmission and final drive assembly.

1. Disconnect negative battery cables.
2. Remove engine access cover.
3. Position engine holding fixture as shown in Figure 28 and adjust mechanism to remove slack from cable.
4. Raise vehicle.
5. Disconnect starting motor wires.
6. Remove starting motor.

7. Remove flywheel cover behind starter.
8. Disconnect manual shift linkage at transmission.
9. Disconnect speedometer cable.
10. Disconnect oil cooler lines at transmission and position out of the way. Cap lines and connectors.
11. Disconnect detent wire and vacuum modulator tube.
12. Disconnect right axle shaft at output shaft flange.
13. Remove right output shaft and support assembly, (includes disconnecting radiator fan venturi ring bracket).

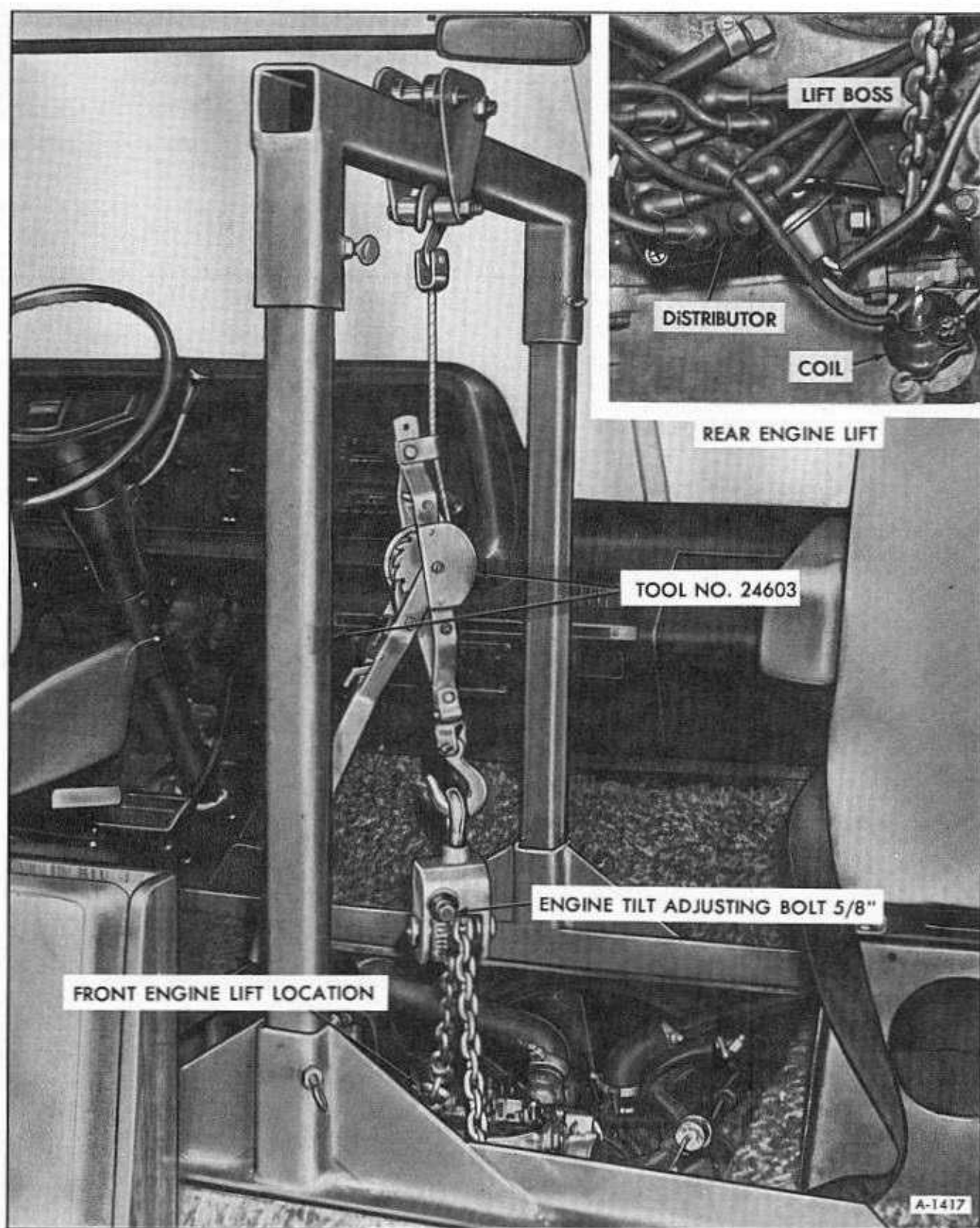

Figure 28—Engine Holding Fixture

14. Disconnect left axle shaft at left output flange.

15. Remove final drive to support bracket through bolt, washers and nut.

16. Remove three (3) converter to flywheel bolts by rotating crankshaft at harmonic balancer.

17. Remove three (3) rear support bracket to transmission bolts.

18. Remove two (2) rear motor mount to support bracket bolts.

19. Position transmission jack under transmission and secure with safety chain around transmission gear case.

20. Remove six (6) transmission converter housing to engine bolts.

21. Move transmission and final drive assembly rearward 1/2"-3/4" and lower from vehicle, installing converter holding clamp, such as J-21366, as soon as transmission is low enough.

## **INSTALLATION OF TRANSMISSION**

1. Position transmission and final drive on jack secured with a safety chain, under the vehicle.

2. Remove converter holding clamp.

3. Raise transmission into place.

4. Loosely install top two (2) converter housing to engine bolts.

5. Slide transmission forward and engage converter pilot into flywheel.

6. Install remaining converter housing to engine bolts. Torque six (6) bolts to 30 ft. lbs.

7. Shift transmission to neutral to align weld nuts to the flywheel. Rotate the crankshaft to install three (3) attaching bolts and torque to 30 ft. lbs. (Note: Weld nuts must be flush to flywheel).

8. Remove safety chain and jack from transmission.

9. Install three (3) rear support bracket to transmission bolts. Torque to 55 ft. lbs.

10. Install two (2) rear motor mount to support bracket bolts. Torque to 55 ft. lbs.

11. Install final drive to support bracket through bolt, washers and nut. Torque bolt to 105 ft. lbs.

12. Connect left axle shaft to output flange using new bolts. Torque bolts to 65 ft. lbs.

13. Install right output shaft and support assembly and fan venturi bracket. Torque bolt to 50 ft. lbs.

14. Connect right axle shaft to output flange using new bolts. Torque bolts to 65 ft. lbs.

15. Connect detent wire and vacuum modulator tube.

16. Connect oil cooler lines. Torque fitting to 20 ft. lbs.

17. Connect speedometer cable.

18. Connect manual shift linkage using a new cotter pin.

19. Install flywheel cover behind starter. Torque bolts to 5 ft. lbs.

20. Connect wires to starting motor.

21. Install starting motor. Torque bolts to 30 ft. lbs.

22. Lower vehicle.

23. Remove engine holding fixture.

24. Connect negative battery cables.

25. Fill transmission with fluid as described under **CHECKING AND ADDING FLUID** in this SECTION.

26. Check manual linkage and adjust if necessary.



# TRANSMISSION OVERHAUL

## REMOVE FINAL DRIVE (FIGURE 29)

1. Remove bolt "A" and transmission dipstick and tube assembly.

2. Remove bolts "B, C, E, F and G" and nut "H". (NOTE: One bolt is omitted between nut "H" and bolt "C".)

3. Remove final drive from transmission, (about 1 quart of transmission fluid will drain).

## REMOVE TORQUE CONVERTER

With transmission on portable jack, remove Converter Holding Clamp, J-21366, and then remove converter assembly from transmission by pulling converter straight out of housing.

**CAUTION:** Converter with oil weighs approximately 50 pounds. Be careful not to drop or damage converter when removing it.

## ARRANGE TRANSMISSION FOR OVERHAUL

1. Install two 3/8 x 8 bolts with nuts into the case to engine mounting face. (figure 30)

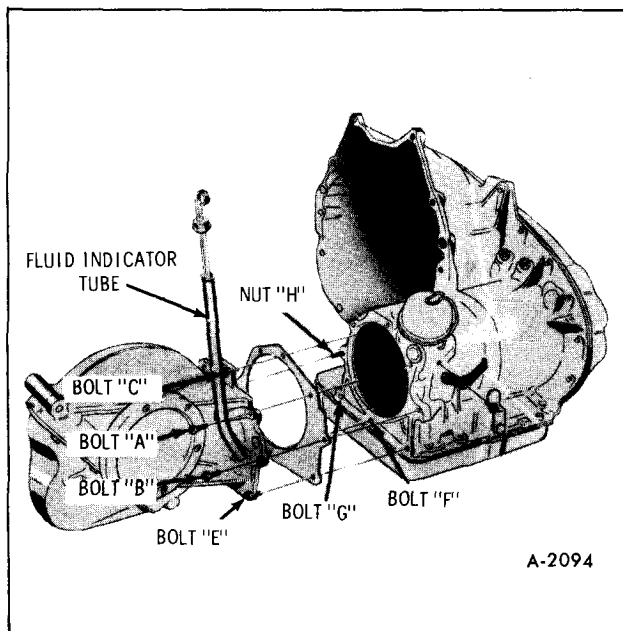

Figure 29—Final Drive Attachment

2. Remove the speedometer driven gear attaching screw and retainer clip. (figure 31)

3. Remove speedometer driven gear assembly from case bore. Remove and discard "O" ring seal.

4. Remove the governor attaching bail wire.

5. Remove governor assembly and "O" ring seal from case bore. (figure 32)

6. Remove stud from output end of case and place a piece of plywood under output end of case, place transmission on work bench with bottom pan facing the outside edge of work bench. (Let pan overhang edge of bench.) Stand transmission on the two eight inch bolts and the output flange end of the transmission case. (figure 33)

## REMOVE VACUUM MODULATOR AND VALVE

**NOTE:** Unit may be removed without removing transmission or bottom pan, after removing vacuum hose.

1. Remove vacuum modulator attaching screw and retainer from transmission case.

2. Remove modulator assembly and O-ring from transmission case. Remove and discard O-ring from vacuum modulator, Figure 34.

3. Remove modulator valve from transmission case.

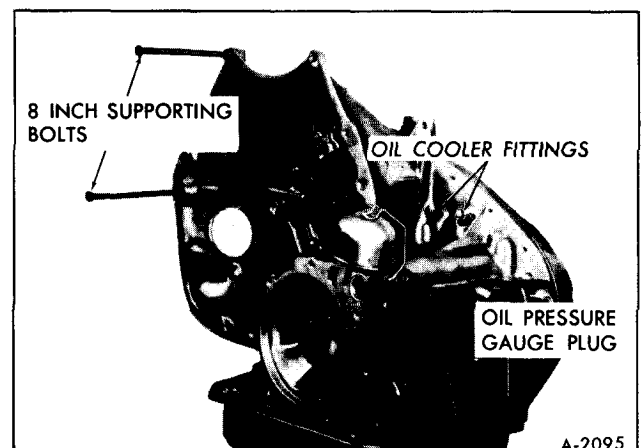

Figure 30—Transmission Support Bolts

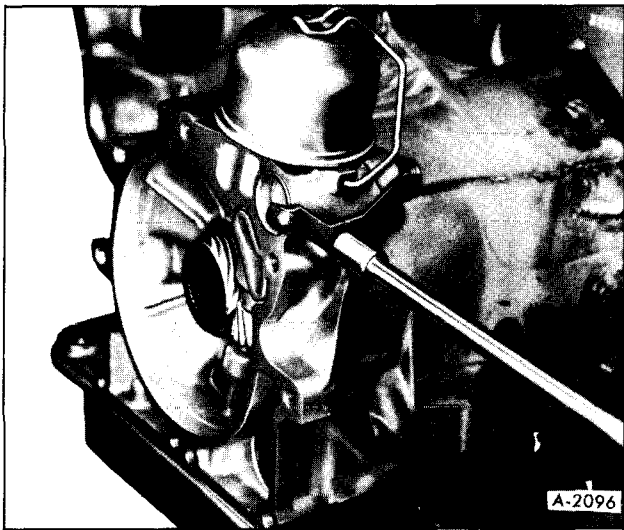

Figure 31—Removing Speedometer Driven Gear Retainer

**NOTE:** Modulator bushing is a snug fit in transmission case and should not be removed forcibly unless it is damaged, scored, or otherwise deformed.

## REMOVE INTAKE PIPE AND FILTER ASSEMBLY AND BOTTOM PAN

**NOTE:** Units may be removed with transmission in vehicle. In cases of transmission failure, intake pipe and filter must be replaced.

1. Remove thirteen bottom pan attaching screws.

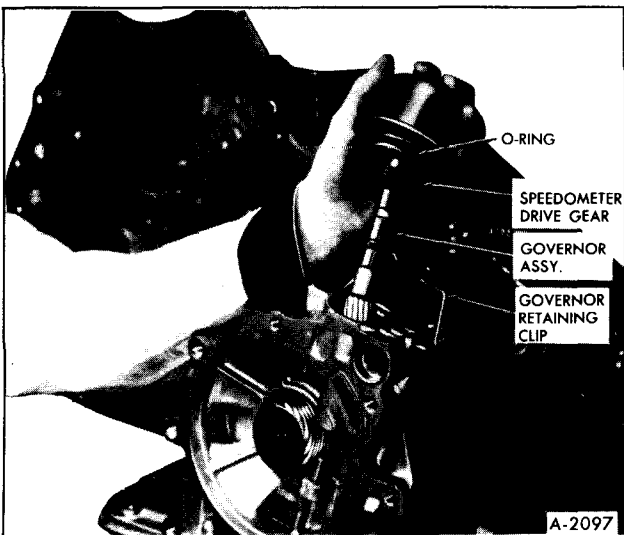

Figure 32—Governor Removal

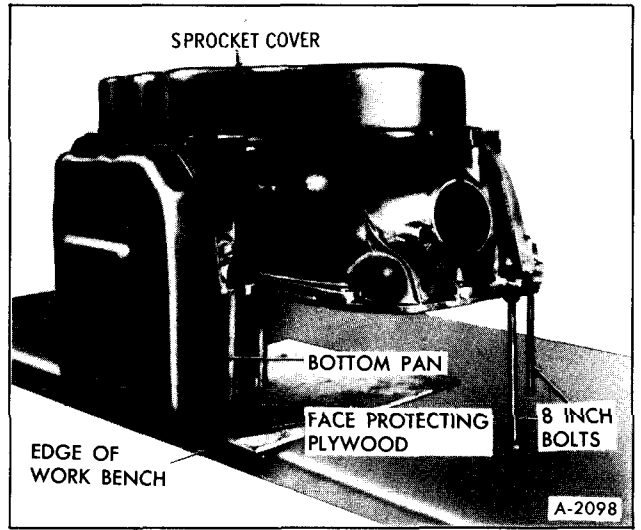

Figure 33—Arrangement of Transmission on Bench

2. Remove bottom pan and discard gasket.
3. Remove oil filter assembly.
4. Remove and discard the intake pipe to case "O" ring seal from the oil filter assembly or from the case counterbore.

## REMOVE PRESSURE REGULATOR VALVE

**NOTE:** Unit may be removed with transmission in vehicle after removing bottom pan.

1. Compress regulator boost valve bushing against pressure regulator spring and remove snap

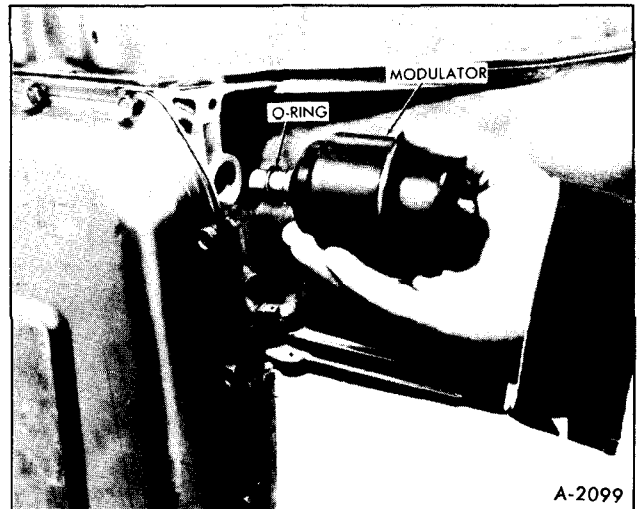

Figure 34—Removing Vacuum Modulator

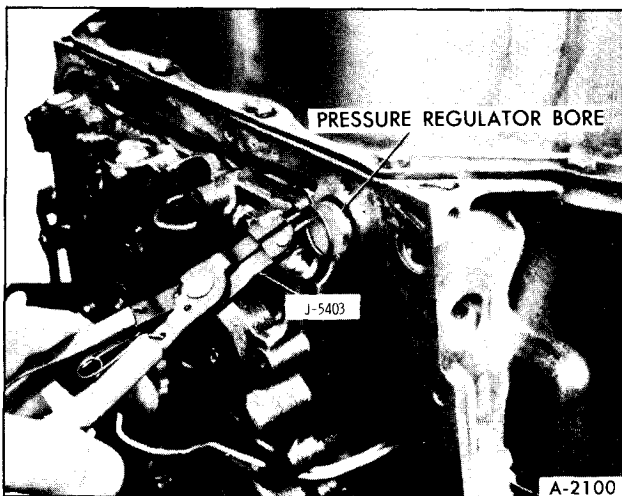

Figure 35—Removing Pressure Regulator Valve

ring using Snap Ring Pliers, J-5403 (#21), Figure 35.

**WARNING: PRESSURE REGULATOR SPRING IS UNDER CONSIDERABLE COMPRESSION.**

2. Remove regulator boost valve bushing and valve.
3. Remove pressure regulator spring.
4. Remove regulator valve, spring retainer, and spacer or spacers if present.

## REMOVE CONTROL VALVE ASSEMBLY, GOVERNOR PIPES, DETENT SPRING, AND ROLLER ASSEMBLY, AND CHECK BALLS

**NOTE:** Units may be removed with transmission in vehicle, after removing bottom pan.

1. Remove attaching screw and remove detent roller and spring assembly.
2. Disconnect detent wire from case connector.
3. Remove governor feed pipe from transmission case and valve body by lifting straight out.
4. Remove nineteen remaining control valve assembly attaching screws. Do not remove detent solenoid attaching screws at this time.

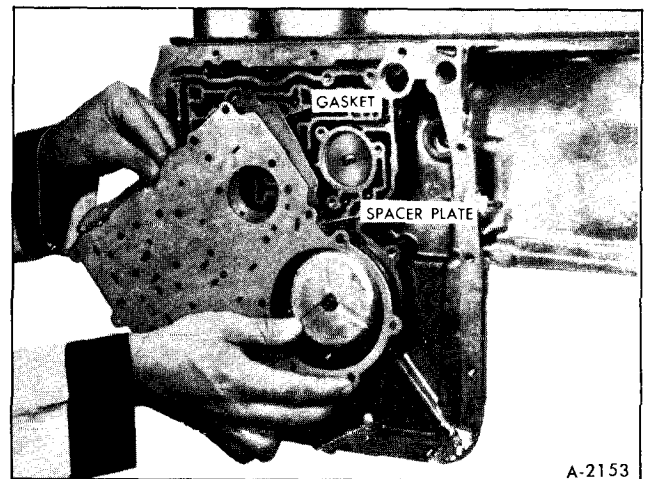

Figure 36—Removing Control Valve Spacer

**NOTE:** If the transmission is in the vehicle, the front servo piston assembly may drop down as the control valve assembly and governor pipe are removed.

5. Remove control valve assembly with remaining governor pipe attached.

**CAUTION:** Do not allow manual valve to fall out of its bore in control valve assembly.

6. Remove remaining governor pipe from valve body.
7. Remove control valve assembly to spacer gasket.
8. Remove control valve spacer and spacer-to-transmission case gasket, Figure 36.

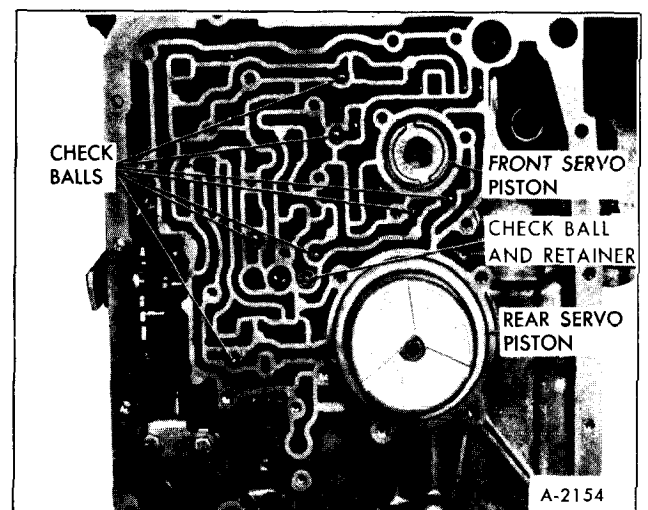

Figure 37—Location of Check Balls

**CAUTION:** *If control valve is removed in vehicle, seven check balls will come down with spacer.*

9. Remove seven check balls from cored passages in transmission case, Figure 37.

**NOTE:** The eighth check ball is held in by a retainer and should not be removed unless replacement is required.

## REMOVE FRONT SERVO PISTON AND REAR SERVO PISTON

**NOTE:** Units may be removed with transmission in vehicle after removing bottom pan and control valve assembly.

1. Lift front servo piston retainer ring, pin, spring retainer and spring out of transmission case, Figure 37.

2. Remove rear servo assembly from transmission case, Figure 37.

3. Remove rear servo accumulator spring.

4. Make band apply pin selection check to determine proper size pin to use at time rear servo is assembled. Proceed as described in the following.

## BAND APPLY PIN SELECTION CHECK (FIGURE 38)

**NOTE:** Check may be made with transmission in vehicle. Remove bottom pan, control valve assembly, and rear servo.

1. Position Adapter Plate, J-21370-8, on transmission case over rear servo bore, and, using screws provided with Adapter Plate, attach Band Apply Pin Selector Gage, J-21370 to Adapter Plate.

2. Position Band Apply Pin Selector Gage, J-21370, with hex nut on side of gage facing toward converter housing, and smaller diameter end of Gage Pin, J-21370-7, in servo pin bore.

3. Secure Adapter Plate to transmission case with two 5/16-18 x 1 inch screws, tightening screws to 18 foot-pounds and secure Selector Gage to Adapter Plate, tighten attaching screws to 18 foot-pounds. Make certain that stepped gage pin is free to move up and down in both tool and servo pin bore. Stepped side of pin must face rear of transmission case.

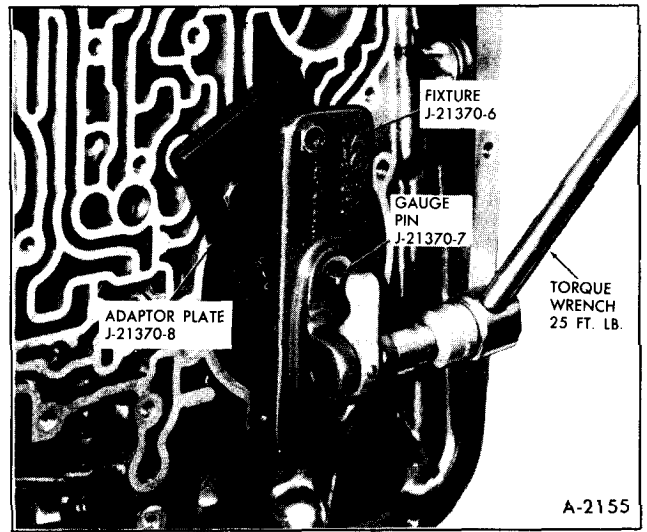

Figure 38—Checking Rear Band Apply Pin Length

Band apply pins are available in three sizes as shown in the following chart:

Identification	Length
Three Rings .....	Long
Two Rings .....	Medium
One Ring .....	Short

Identification ring is located on band lug end of pin. Selecting the proper pin is equivalent to adjusting band.

4. To determine proper size pin to use, apply 25 foot-pounds torque on hex nut on side of gage. This will cause lever on top of gage to depress stepped gage pin into servo pin bore, simulating actual operating conditions. Note relation of steps on gage pin and machined surface on top of gage. Determine proper size pin as follows:

a. If machined surface on top of gage is even with or above upper step on gage pin, long size pin (three rings) is required.

b. If machined surface on top of gage is even with or below lower step on gage pin, short size pin (one ring) is required.

5. If new pin is required, make note of pin size required, and remove gage from transmission case.

## REMOVE DETENT LEVER, MANUAL SHAFT, AND PARKING LINKAGE (FIGURE 39)

**NOTE:** Units may be removed with transmission in vehicle after removing bottom pan and detent roller and spring assembly from control valve assembly.

1. Remove pin securing manual shaft to case by pulling straight out, (Be careful not to damage the case or pin).

2. Loosen locknut securing detent lever to manual shaft.

3. Pry or work detent lever loose from ground flats on manual shaft.

4. Remove manual shaft from case bore and remove and discard O-ring seal from manual shaft.

**NOTE:** Be careful not to drop jam nut inside of case.

5. Remove detent lever and parking brake actuator assembly from case and remove actuator assembly from detent lever.

6. Remove parking brake bracket attaching screws and remove bracket.

7. Remove retainer pin securing parking pawl shaft to transmission case by pulling straight out.

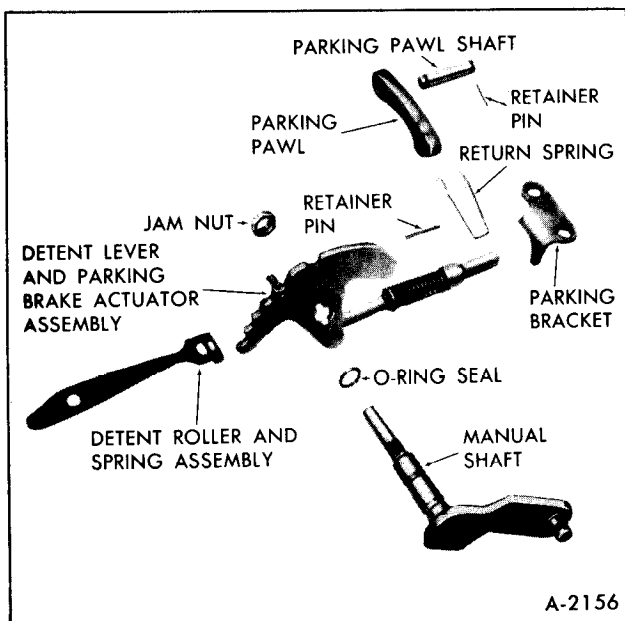

Figure 39—Manual and Parking Linkage

8. Remove parking pawl shaft, parking pawl and return spring.

## REMOVE SPROCKET COVER, LINK ASSEMBLY, DRIVE AND DRIVEN SPROCKETS

1. Remove eighteen cover attaching screws.

2. Remove cover and gasket and discard gasket.

3. Install Snap Ring Pliers, J-4646, into sprocket bearing retaining snap rings located under the drive and driven sprockets, and remove snap rings from retaining grooves on support housing, Figure 40.

**NOTE:** Leave snap rings in a loose position between sprockets and bearing assemblies.

4. Remove drive and driven sprockets, link assembly, bearings, and shafts simultaneously by alternately pulling upwards on the drive and driven sprockets until the bearings are out of the drive and driven support housings, Figure 41.

**NOTE:** If the sprockets are difficult to remove, place a small piece of fiberboard between the sprocket and sprocket support cover. Using a 1/2 x 9 inch pry bar, alternately pry upward under each sprocket on sprocket support cover. Do not pry on the guide links or the aluminum case. Pry only on the sprockets, Figure 42.

5. Remove link assembly from drive and driven sprockets.

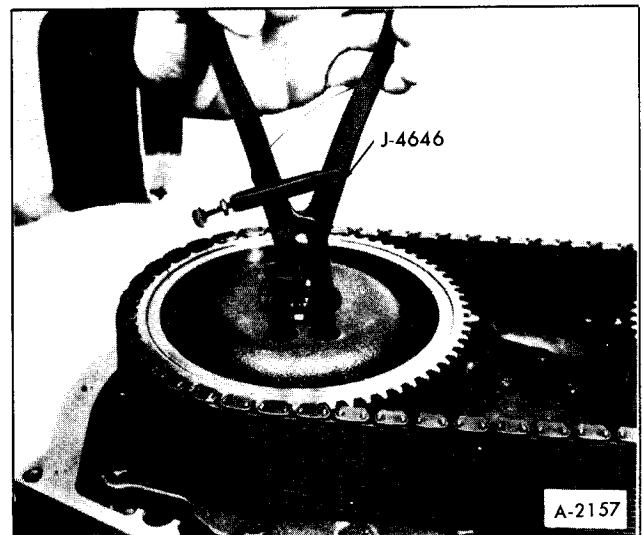

Figure 40—Removing Sprocket to Housing Snap Rings

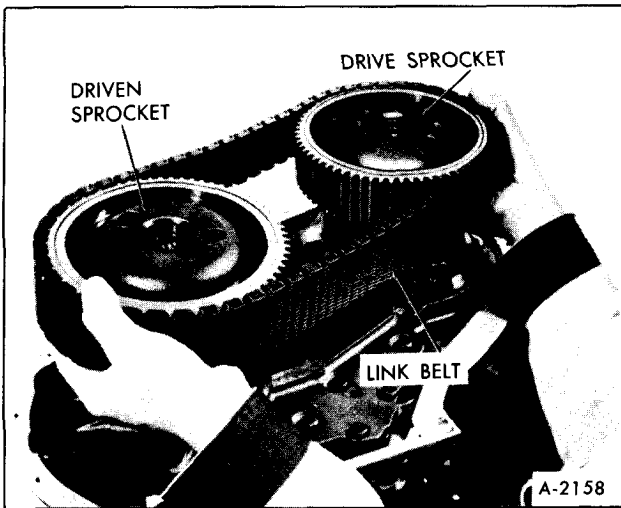

Figure 41—Removing Sprocket & Link Assembly

6. Remove the hook type oil seal ring from turbine shaft.

7. Inspect drive and driven sprocket bearing assemblies for rough or defective bearings.

**NOTE:** Do not remove bearing assemblies from drive and driven sprockets unless they need replacement.

8. If removal of bearing assembly from drive and/or driven sprockets is necessary, proceed as follows:

a. Remove sprocket to bearing assembly retaining snap ring using Snap Ring Pliers, J-8059, Figure 43.

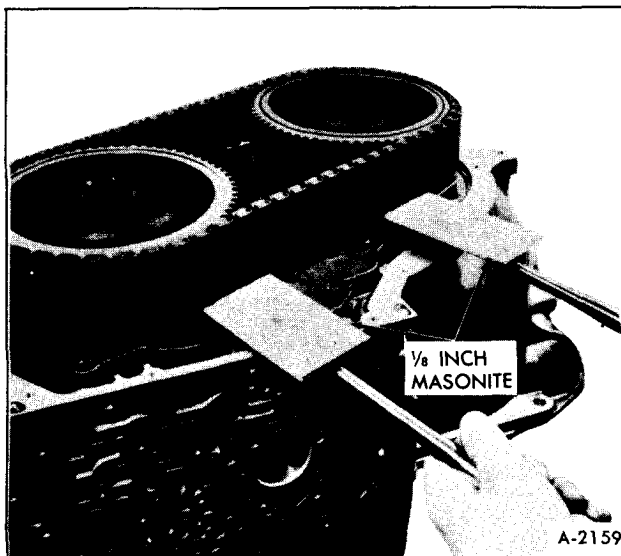

Figure 42—Removing Tight Sprockets

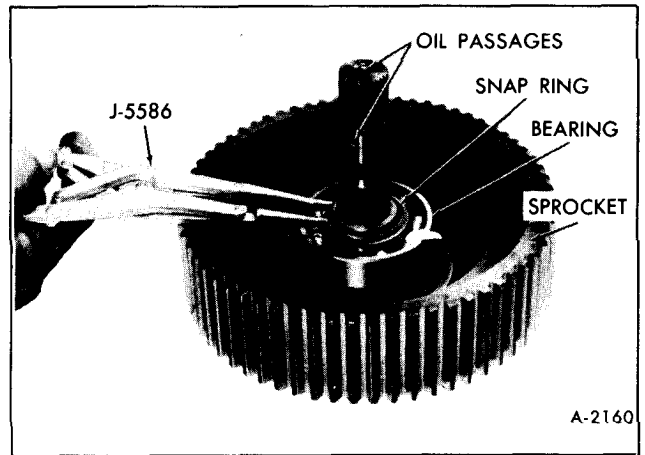

Figure 43—Removing Sprocket Bearing Snap Ring

b. Mount sprocket, with turbine or input shaft placed down between two 2" x 4" x 10" wood blocks.

**NOTE:** Wood blocks are positioned on sides or ends, depending on which bearing is to be replaced.

c. With a hammer and brass rod, drive the inner race, alternately through each of the access openings, until the bearing assembly is removed from the sprocket hub, Figure 44.

## INSPECT DRIVE SPROCKET, TURBINE SHAFT, AND LINK ASSEMBLY

1. Inspect drive sprocket teeth for nicks, burrs, scoring, galling, and excessive wear.

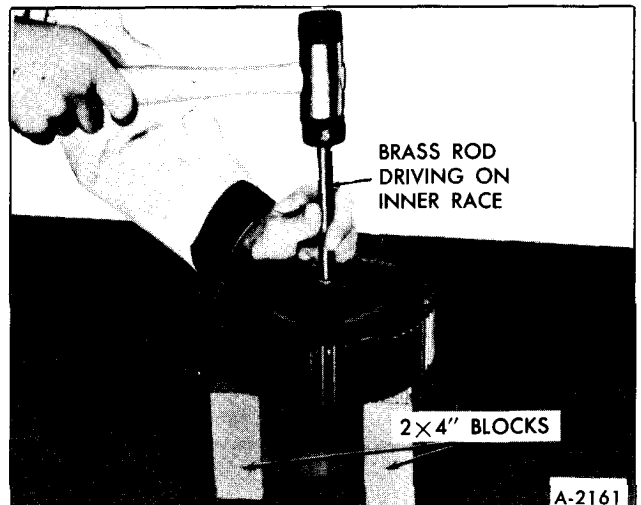

Figure 44—Removing Sprocket Bearing

**NOTE:** Wear pattern at bottom of tooth form is normal.

2. Inspect drive sprocket to ball bearing retaining snap ring for damage.
3. Inspect drive sprocket ball bearing inner race mounting surface for damage.
4. Inspect turbine shaft for open lubrication passages. Run a tag wire through the passages to be sure they are open. See lubrication chart for passage location, Figure 19.
5. Inspect spline for damage.
6. Inspect the ground bushing journals for damage.
7. Inspect the hook type oil seal groove for damage or excessive wear.
8. Inspect the turbine shaft for cracks or distortion.
9. Inspect the link assembly for damage or loose links.

**NOTE:** Check the guide links. Guide links are the wide outside links on each side of the link assembly.

## INSPECT DRIVEN SPROCKET AND INPUT SHAFT

1. Inspect driven sprocket teeth for nicks, burrs, scoring, galling, and excessive wear.

**NOTE:** Wear pattern at bottom of tooth form is normal.

2. Inspect sprocket to ball bearing retaining snap ring for damage.
3. Inspect ball bearing inner race mounting surface for damage.
4. Inspect input shaft for open lubrication holes. Run a tag wire through the holes to be sure they are open. See Figure 19 for location of holes.
5. Inspect spline for damage.
6. Inspect ground bushing journal for damage.

## INSTALL SPROCKET BEARINGS

1. Turn sprocket so that turbine or input shaft is pointing upward.

2. Install new sprocket bearing as follows:

- a. Install support snap ring, letter side down onto shaft.
- b. Assemble bearing assembly on turbine or input shaft.
- c. Using a piece of pipe, drive the bearing assembly onto the hub of the sprocket until it is resting on the bearing seat of the sprocket.

**CAUTION:** Use pipe that closely fits I.D. of bearing assembly but does not contact shaft.

- d. Install sprocket to bearing assembly retaining snap ring into groove in sprocket hub.

3. Install new hook type oil seal ring on turbine shaft, (Note: original ring is plastic).

**NOTE:** Turbine and/or input shaft may appear not to be pressed fully into the sprocket. Do not attempt pressing shaft further as a specific length dimension is held during initial assembly.

## FRONT UNIT END PLAY CHECK

1. Install Front Unit End Play Checking Tool, J-22241, into driven sprocket housing so that the urethane on the tool can engage the splines in the forward clutch housing. Let the tool bottom on the mainshaft and then withdraw it approximately 1/8 inch and tighten nut on tool, Figure 45.

2. Remove two of the 5/16" bolts from the driven support housing.

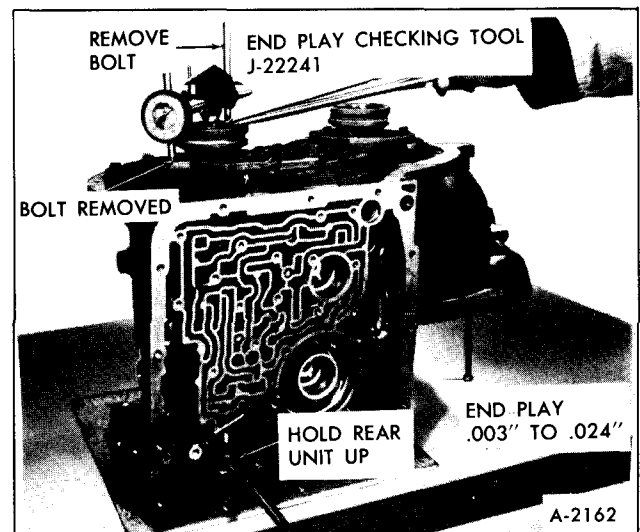

Figure 45—Checking Front Unit End Play

Install 5/16" threaded slide hammer bolt with jam nut into one bolt hole in driven support housing.

**NOTE:** Do not thread slide hammer bolt deep enough to interfere with forward clutch housing travel.

3. Mount Dial Indicator, such as J-8001, on slide hammer bolt and index indicator to register with the Front Unit End Play Checking Tool, J-22241, Figure 45 and push tool down to remove slack.

4. Push and hold output flange upward. Place a screw driver in case opening at parking pawl area and push upward on output carrier.

5. Place another screw driver between the metal lip of the end play tool and the driven sprocket housing and push upward on the metal lip of the end play tool and read the resulting end play, which should be between .003" and .024".

The selective washer controlling this end play is the thrust washer located between the driven support housing and the forward clutch housing. If more or less washer thickness is required to bring the end play within specifications, select the proper washer from the chart below:

THICK- NESS	COLOR
.060-.064	Yellow
.071-.075	Blue
.082-.086	Red
.093-.097	Brown
.104-.108	Green
.115-.119	Black
.126-.130	Purple

**NOTE:** An oil soaked washer may tend to discolor so that it will be necessary to measure the washer with a set of one inch micrometers to determine its actual thickness.

6. Remove end play tool from transmission and remove dial indicator and slide hammer bolt from transmission.

## REMOVE OIL PUMP

1. Remove two opposite pump attaching bolts from the drive support housing.

2. Install two 5/16-18 x 4" guide pins in holes from previously removed bolts.

3. Remove the remaining pump attaching bolts from the drive support housing.

4. With one hand hold the underside of the pump and gently tap the guide pins until the pump is removed from the case.

## REMOVE PUMP COVER PLATE, CONVERTER OUT CHECK VALVE AND DRIVE AND DRIVEN SUPPORT HOUSING ASSEMBLIES

1. Remove the twenty-three pump cover plate-to-case attaching screws and remove pump cover plate. Do not remove sprocket support housing bolts at this time.

2. Remove pump cover plate and plate-to-case face gasket. Discard gasket.

**NOTE:** Drive and driven support housing assemblies are pressed into and removed with the pump cover plate. Do not remove them unless it is necessary.

3. Remove oil seal rings from the driven support housing.

4. Remove the front unit end play selective thrust washer from the hub of the driven support housing.

5. If necessary to remove the drive and driven sprocket support housing assemblies, proceed as follows:

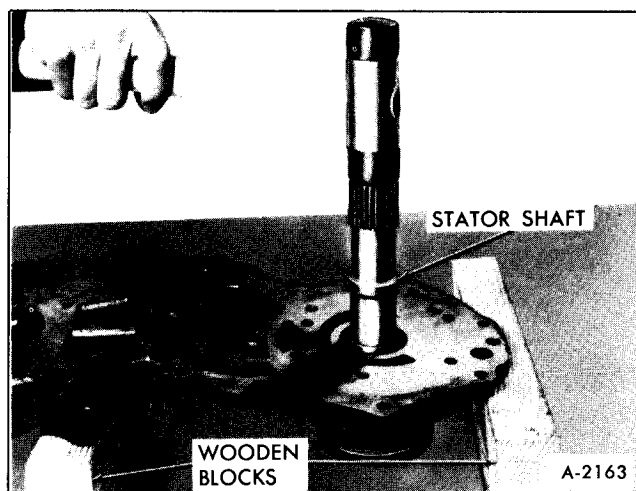

Figure 46—Removing Drive Sprocket Support



a. Remove the remaining sprocket support to pump cover plate attaching bolts.

b. Support cover plate on wooden blocks and using a plastic mallet, vigorously strike the stator shaft of the drive sprocket support, Figure 46, and the hub of the driven sprocket support, until they are removed from their pump cover plate bores.

**CAUTION:** *When driving the housings out of the pump cover plate, avoid damaging or distorting the stator shaft or the ring grooves in the hub of the driven housing by striking the shaft or hub centrally.*

c. Remove and discard housing to pump cover plate gaskets.

d. Remove converter out check valve, Figure 47.

e. Install converter out check valve.

f. Install drive sprocket support housing to pump cover plate gasket.

g. Install drive sprocket support housing into pump cover plate by using a plastic mallet to seat the housing. Use bolts for guides, Figure 48.

h. Install driven sprocket support housing to pump cover plate gasket.

i. Install driven sprocket support housing to pump cover plate attaching bolts for gasket guides.

j. Install driven sprocket support housing into

pump cover plate by using a plastic mallet to seat the housing.

k. Install all but one driven support housing to pump cover plate attaching bolts. Torque to 20 ft. lbs.

6. Install proper front unit end play selective thrust washer on the hub of the driven sprocket support housing. Use micrometer to determine the actual thickness of the thrust washer.

7. Install one hook type and one teflon oil seal ring into the grooves in the hub of the driven sprocket support housing.

## REMOVE FORWARD CLUTCH ASSEMBLY, DIRECT CLUTCH ASSEMBLY, SUN GEAR SHAFT, AND FRONT BAND

1. Remove forward clutch assembly from transmission, Figure 49, by installing Front End Play Checking Tool, J-22241, into forward clutch and lifting forward clutch straight out.

2. Remove forward clutch hub to direct clutch housing thrust washer if it did not come out with forward clutch assembly.

3. Remove direct clutch and intermediate sprag assembly by lifting straight out. Sun gear shaft may come out with direct clutch assembly.

4. Remove sun gear shaft if not previously removed.

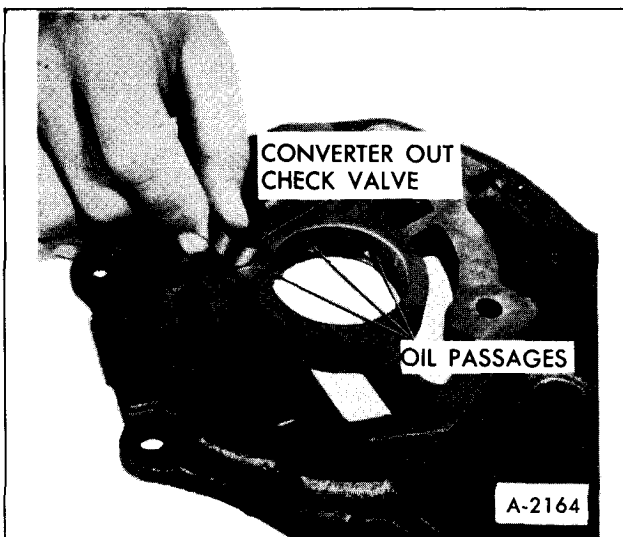

Figure 47—Converter Out Check Valve

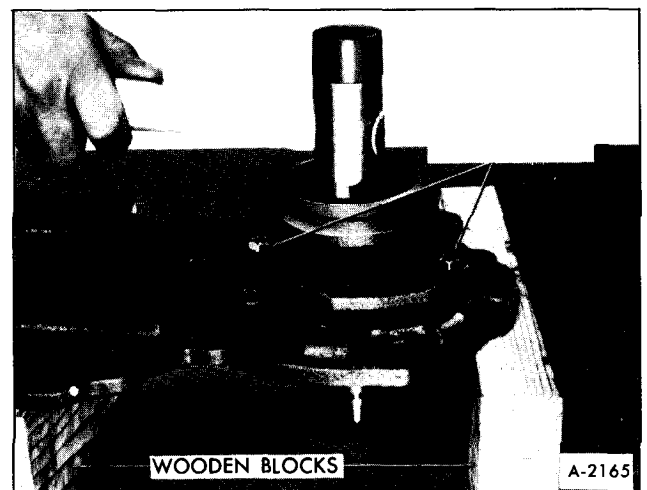

Figure 48—Installing Drive Sprocket Support

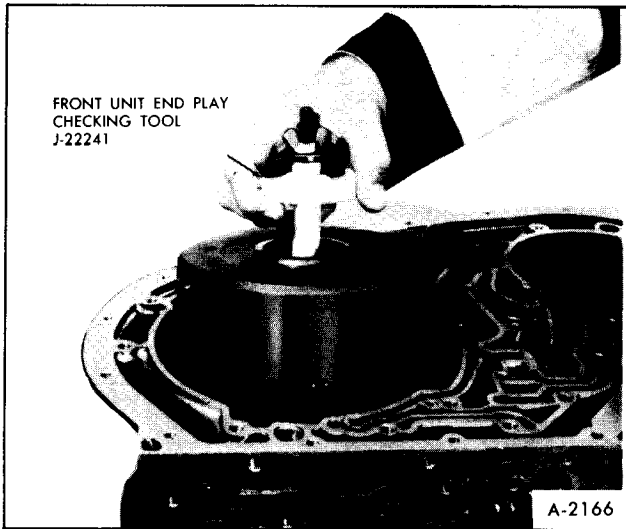

Figure 49—Removing Forward Clutch

5. Remove front band assembly.

**NOTE:** Check rear unit end play at this time.

## REAR UNIT END PLAY CHECKING PROCEDURE

Make rear unit end play check as follows:

a. Install 3/8" bolt for slide hammer into one

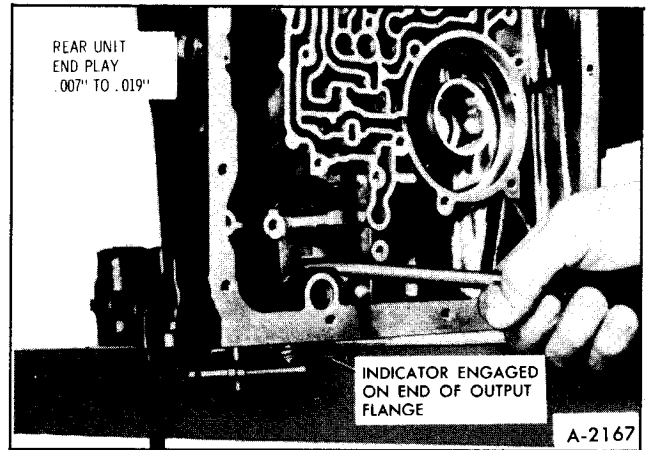

Figure 50—Rear Unit End Play

of the final drive attaching bolt holes. Allow end of case to hang over edge of bench, Figure 50.

b. Mount dial indicator on the bolt and index with end of output flange.

c. Move the output flange in and out to read the end play. End play should read .007" to .019". The selective washer controlling this end play is the steel washer having three lugs that is located between the output flange thrust washer and the rear face of the transmission case.

If a different washer thickness is required to bring the end play within specifications, it can be selected from the following chart:

Thickness	Notches and/or Numeral
.074" to .078"	None ..... 1
.082" to .086"	1 Tab Side..... 2
.090" to .094"	2 Tab Side..... 3
.098" to .102"	1 Tab O.D. .... 4
.106" to .110"	2 Tabs O.D. .... 5
.114" to .118"	3 Tabs O.D. .... 6

## REMOVE REMAINING COMPONENTS

1. Remove center support bolt from transmission case, Figure 51, using a 3/8 inch 12-point thin wall deep socket.

2. Remove intermediate clutch backing plate to case snap ring, Figure 52.

3. Remove intermediate clutch backing plate, and three composition and three steel clutch plates.

4. Using a needle-nose pliers, or screwdriver, remove center support to case snap ring, Figure 53.

5. Install Gear Assembly Remove and Installer Adapter, J-21795, on end of main shaft so that tangs engage groove in shaft. Using Slide Hammer Handle, such as J-6125, and Speedometer Puller Bolt, J-

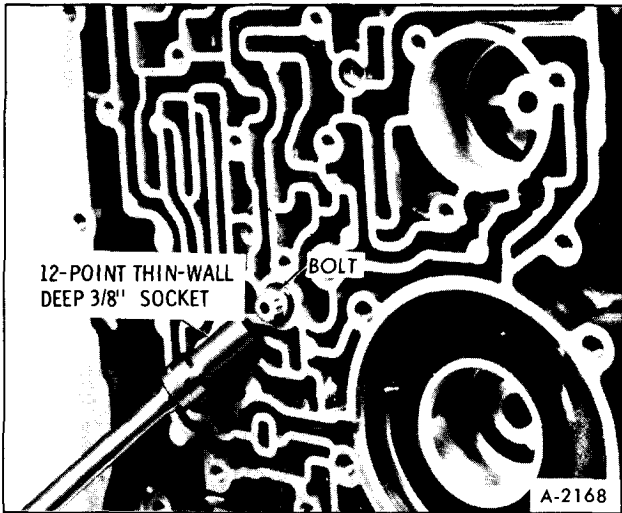

Figure 51-Remove Center Support Bolt

21797, tighten bolt on tool to secure tool on shaft, Figure 54.

6. Remove complete gear unit assembly from case, by lifting straight up.

**CAUTION:** *Be careful not to drop or bump assembly in transmission case during removal.*

7. Remove output flange to case metal thrust washer from output flange or case.

8. Place gear unit assembly on bench with output flange down, Figure 55. Remove Tool J-21795.

9. Remove support to case spacer.

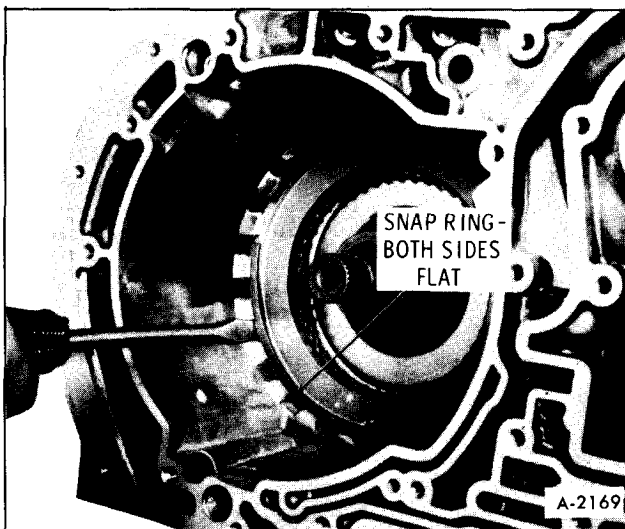

Figure 52-Intermediate Clutch Snap Ring

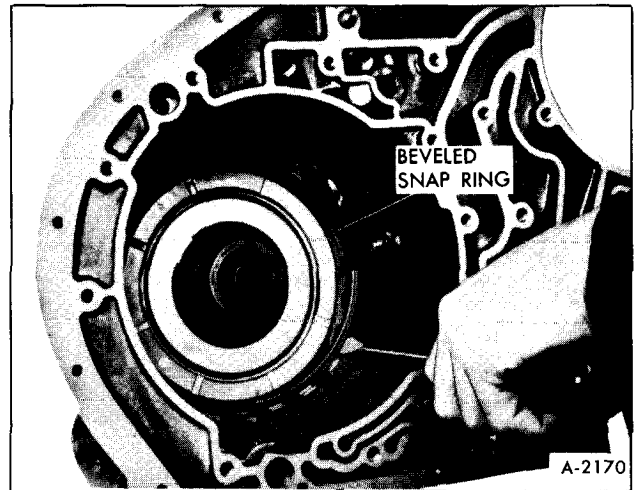

Figure 53-Center Support Snap Ring

10. Remove rear band assembly. To facilitate removal, rotate band lugs away from pins and pull band assembly out of transmission case.

11. Remove rear unit selective washer from transmission case.

## INSPECTION OF TRANSMISSION CASE

1. Inspect case assembly for cracks, porosity or interconnected passages, Figure 20.

2. Check for good retention of band anchor pins.

3. Inspect all threaded holes for thread damage. (use insert to rebores threads if necessary).

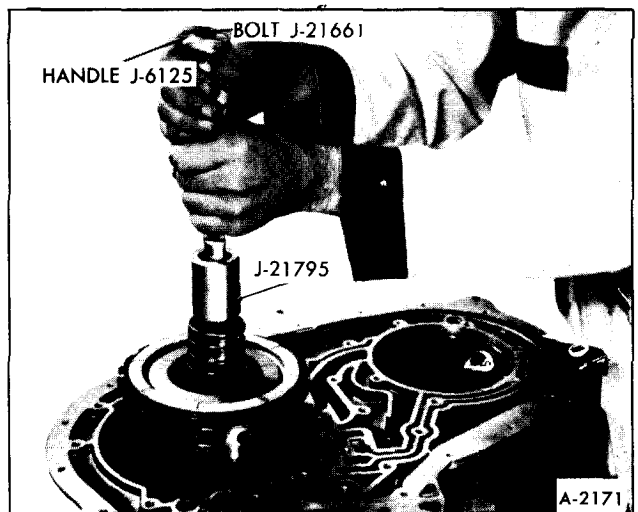

Figure 54-Gear Unit Removal

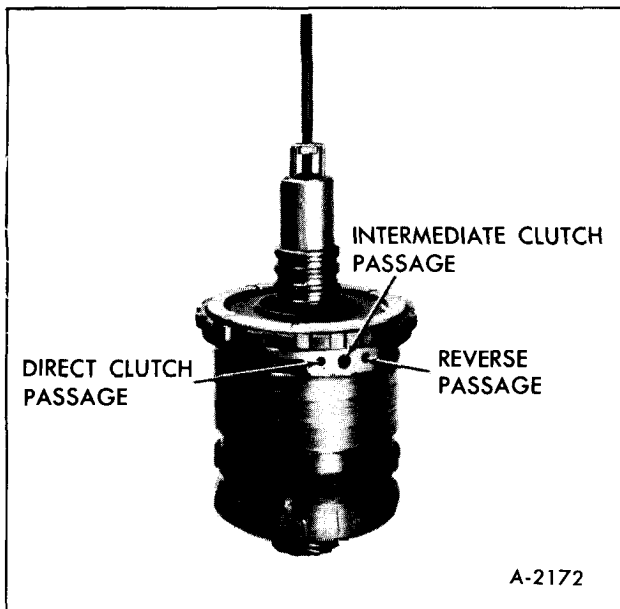

Figure 55—Gear Unit on Bench

4. Inspect intermediate clutch driven plate lugs for damage or brinelling.
5. Inspect snap ring grooves for damage.
6. Inspect governor assembly bore for scratches or scoring.
7. Inspect governor pipes screen assemblies (located in governor pipe holes in case) for plugging or damage.
8. Inspect modulator valve bore for scoring or damage.
9. Inspect output flange bushing for wear, galling and open lubrication groove.

## CENTER SUPPORT AND GEAR UNIT

### DISASSEMBLY

1. Remove center support assembly from reaction carrier by lifting center support straight up.
2. Remove center support to reaction carrier thrust washer.

**NOTE:** Thrust washer may have stuck to back of center support. If so, remove from center support.

3. Remove reaction carrier and roller clutch as-

sembly from output carrier, Figure 56, and remove roller clutch assembly from reaction carrier.

4. Remove center support to sun gear races and thrust bearing from sun gear.

**NOTE:** One of the races may have stuck to back of center support.

5. Remove front internal gear ring from output carrier assembly, Figure 57.

6. Remove sun gear from output carrier assembly.

7. Remove reaction carrier to output carrier plastic thrust washer from output carrier.

8. Invert gear unit and place in Rear Unit Holding Fixture, J-6116, with main shaft pointing downward.

9. Remove snap ring securing output flange to output carrier and remove output flange.

10. Remove thrust bearing and races from rear internal gear.

11. Lift rear internal gear and main shaft out of output carrier and remove thrust bearing and races from inner face of rear internal gear.

12. Remove snap ring from end of main shaft and remove rear internal gear.

13. Remove output carrier from holding fixture.

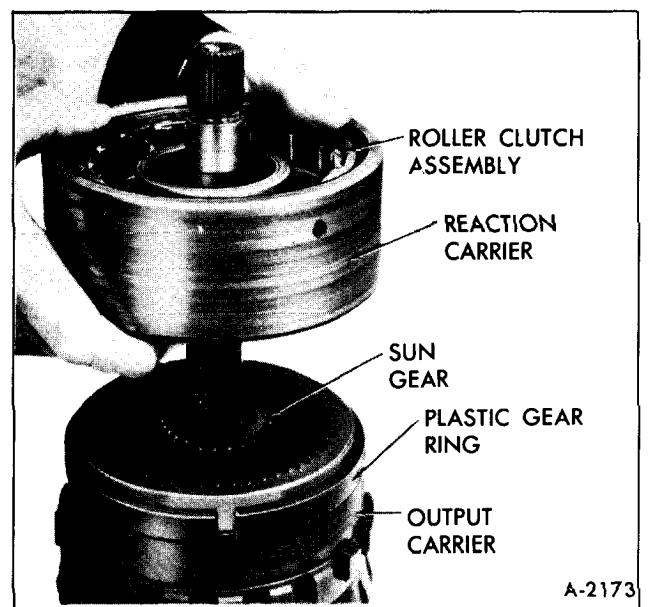

Figure 56—Removing Reaction Carrier

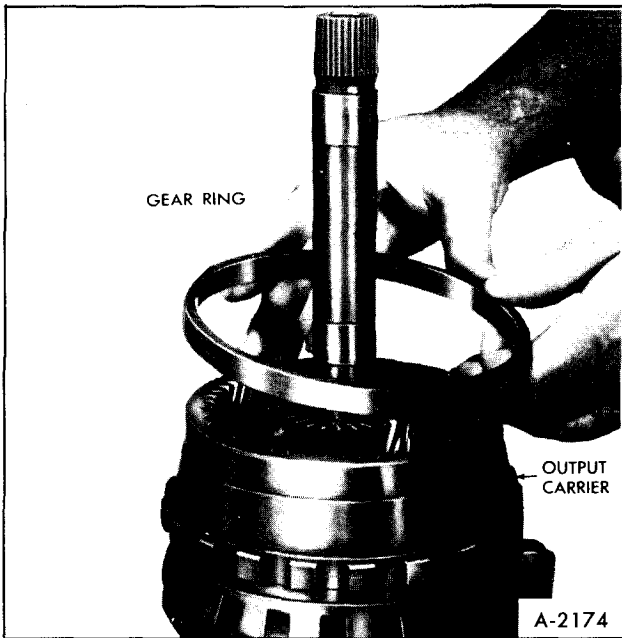

Figure 57—Removing Gear Ring

## INSPECT OUTPUT FLANGE

1. Inspect bearing and thrust washer surfaces for damage.
2. Inspect drive lugs for damage.
3. Inspect splines for damage.
4. Inspect lubrication passages.

## INSPECT MAIN SHAFT

1. Inspect shaft for cracks or distortion.
2. Inspect splines for damage.
3. Inspect ground bushing journals for damage.
4. Inspect snap ring groove for damage.
5. Inspect lubrication passages.

## INSPECT REAR INTERNAL GEAR

1. Inspect gear teeth for damage or wear.
2. Inspect splines for damage.
3. Inspect gear for cracks.

4. Inspect bearing and thrust surfaces for wear or galling.

## INSPECT OUTPUT CARRIER

1. Inspect front internal gear for damaged teeth.
2. Inspect pinion gears for damage, rough bearings or excessive tilt.
3. Check pinion end play. Pinion end play should be .009 inch-.024 inch, Figure 58.
4. Inspect parking gear lugs for cracks or damage.
5. Inspect output flange locating splines for damage.
6. Inspect front internal gear ring for flaking or cracks.

## INSPECT REACTION CARRIER

1. Inspect band surface on reaction carrier for signs of burning or scoring.
2. Inspect roller clutch outer cam for scoring or wear.
3. Inspect thrust washer surfaces for signs of scoring or wear.
4. Inspect bushing for damage. If bushing is damaged, carrier must be replaced.
5. Inspect pinion gears for damage, rough bearings or excessive tilt.
6. Check pinion end play. Pinion end play should be .009 inch-.024 inch.

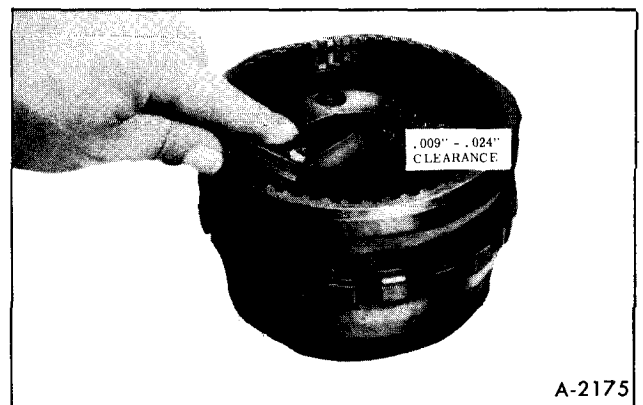

Figure 58—Check-Pinion End Play

## PINION GEAR REPLACEMENT-REACTION AND OUTPUT CARRIER ASSEMBLIES

1. Support carrier assembly on its FRONT face.

2. Using a 1/2 inch diameter drill, remove the stake marks from the end of the pinion pin, or pins, to be replaced. This will reduce the probability of cracking the carrier when the pinion pins are pressed out.

**CAUTION:** *Do not allow drill to remove any stock from the carrier, as this will weaken the part, and could cause the carrier to break.*

3. Using a tapered punch, drive or press pinion pins out of carrier.

4. Remove pinion gears, thrust washers, and roller needle bearings.

5. Inspect pinion pocket thrust faces for burrs and remove if present.

6. Install eighteen needle bearings into each pinion gear using petrolatum to hold bearings in place. Use a pinion pin as a guide.

7. Place a bronze and steel thrust washer on each side of pinion gear with steel washers against gear, Figure 59. Hold washers in place with petrolatum.

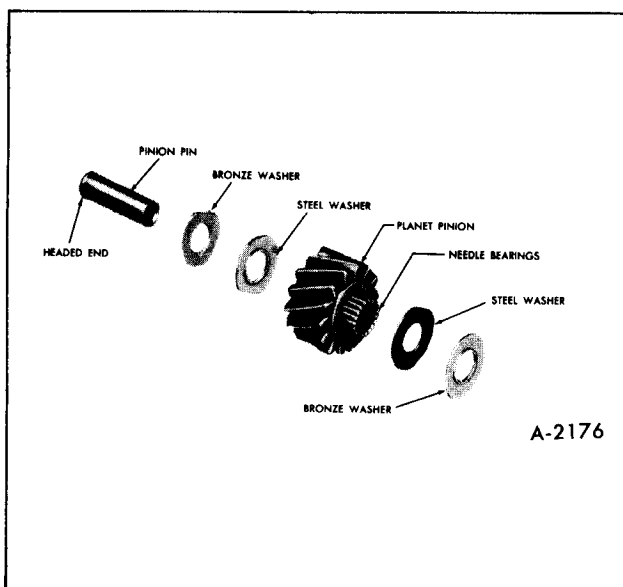

Figure 59—Planet Pinion Components

8. Place pinion gear assembly in position in carrier and install a pilot shaft through rear face of assembly to hold parts in place.

9. Drive a new pinion pin into place from the front, while rotating pinion gear. Be sure that headed end is flush or below face of carrier.

10. Using a punch in bench vise for an anvil, stake opposite end of pinion pin in three places with a blunt radius chisel, Figure 60.

**NOTE:** Both ends of pinion pins must lie below face of carrier or interference may occur.

11. Repeat installation procedure for each pinion gear.

## INSPECT ROLLER CLUTCH

1. Inspect roller clutch for damaged rollers or springs.

2. Inspect roller clutch cage for damage.

## INSPECT SUN GEAR

1. Inspect gear teeth for damage or wear.

2. Inspect splines for damage.

3. Be sure oil lubrication hole is open.



Figure 60—Staking Pinion Pin

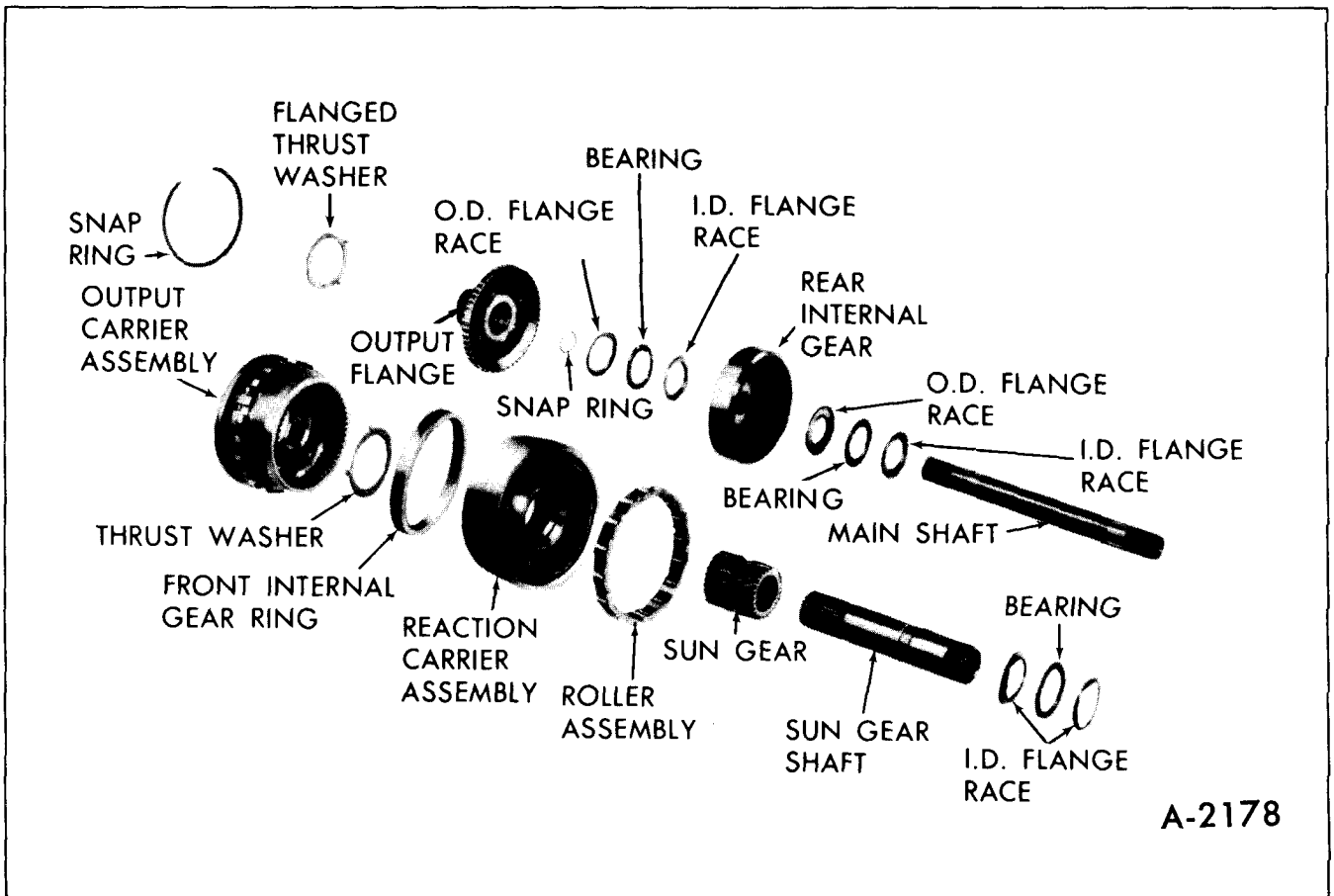

A-2178

Figure 61-Gear Unit Components

## INSPECT SUN GEAR SHAFT

1. Inspect shaft for cracks or splits.
2. Inspect splines for damage.
3. Inspect bushings for scoring or galling.
4. Inspect ground bushing journals for damage.
5. Be sure oil lubrication hole is open.

## ASSEMBLE GEAR UNIT (FIGURE 61)

1. Install rear internal gear on end of main shaft that has snap ring groove and install snap ring.
2. Install races and thrust bearing on inner face of rear internal gear, retaining races and bearing with petrolatum. Proceed as follows:
  - a. Install large diameter race first, with flange facing up, Figure 62.
  - b. Install thrust bearing in race.
  - c. Install small diameter race on bearing with inner flange facing down.

3. Lubricate pinion gears in output carrier with transmission fluid and install output carrier on main shaft so that pinion gears mesh with rear internal gear.

4. Place the above portion of the build-up through hole in bench so that the mainshaft hangs downward.

5. Install the rear internal gear to output flange thrust races and bearings as follows: (Retain with petrolatum) (figure 63).

- a. Place the small diameter race against the internal gear with the center flange facing up.
- b. Place the bearing on the race.

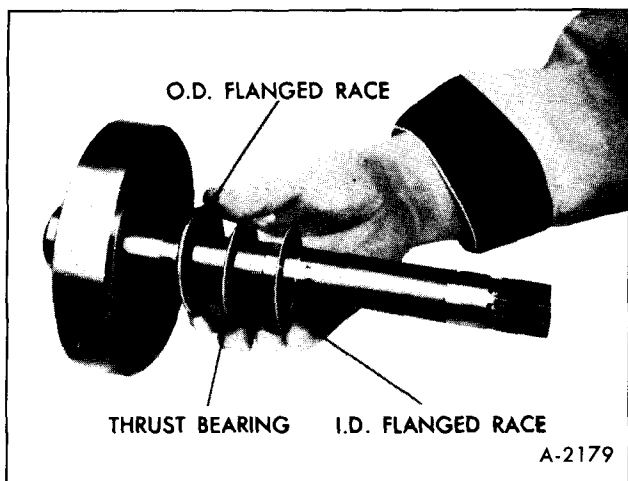

Figure 62—Thrust Bearing Installation

c. Place the second race on the bearing with the outer flange cupped over the bearing.

6. Install the output flange into the output carrier assembly.

7. Install the output flange to the output carrier snap ring.

8. Invert assembly and place on bench with output flange downward.

9. Lubricate tab side of reaction carrier to output carrier thrust washer with petrolatum and install thrust washer in output carrier with tabs in tab pockets.

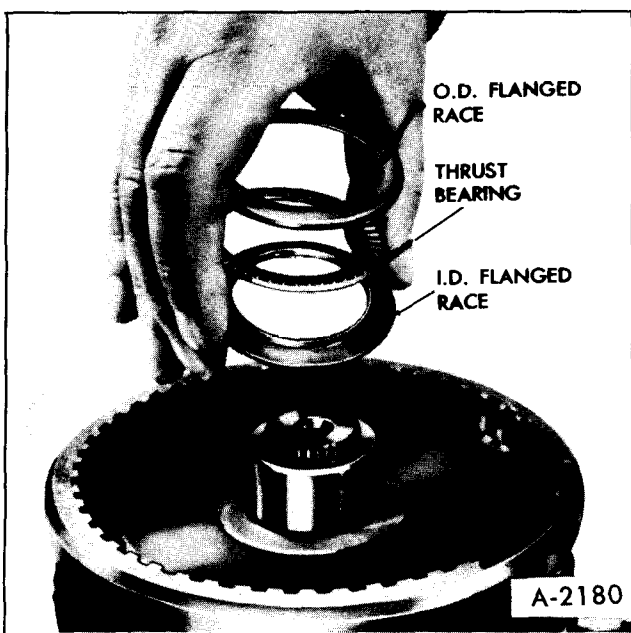

Figure 63—Installing Output Flange Thrust Bearing

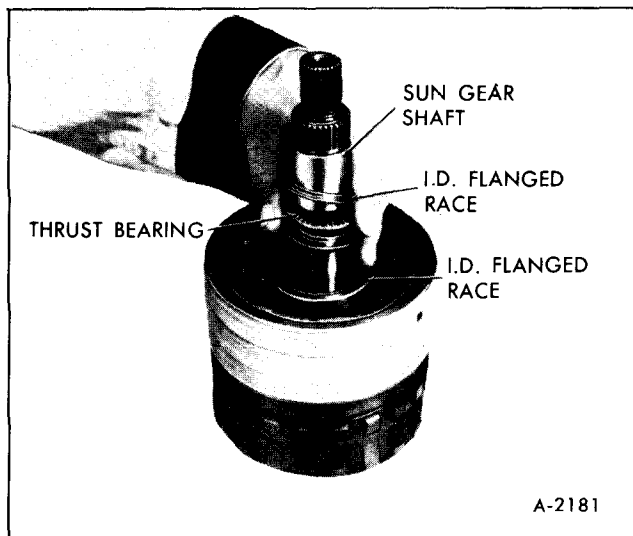

Figure 64—Installing Thrust Bearing over Sun Gear Shaft

10. Install sun gear with end having chamfered I.D. facing down.

11. Install sun gear shaft with longer splined end down.

12. Install gear ring over output carrier.

13. Lubricate pinion gears in reaction carrier with transmission fluid and install reaction carrier on output carrier so that pinion gears mesh with front internal gear.

**NOTE:** When a new output carrier and/or reaction carrier is being installed, and if the front internal gear ring prevents assembly of the carriers, replace the front internal gear ring with the service ring. The front internal gear ring is a selective fit at the factory, but not in service.

14. Install large diameter O.D. race on sun gear with flange facing up against sun gear shaft.

15. Install thrust bearing on race.

16. Lubricate small diameter race with petrolatum and install race on center support with flange facing toward tower end, Figure 64.

17. Install rollers that may have come out of roller clutch cage, by compressing energizing spring with forefinger and inserting roller from outer side.

**NOTE:** Make certain that energizing springs are not distorted, and that curved end leaf of springs are positioned against rollers.

18. Install roller clutch assembly in reaction carrier, Figure 65.



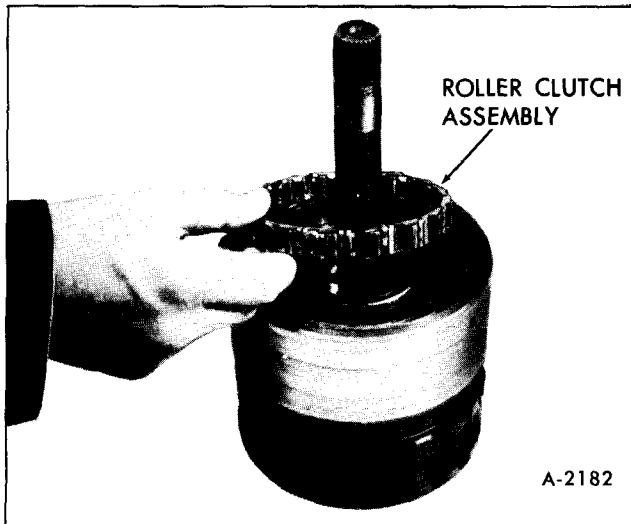

Figure 65—Roller Clutch Installation

## DISASSEMBLE CENTER SUPPORT AND INTERMEDIATE CLUTCH PISTON

1. Remove center support to reaction carrier thrust washer from recess in center support.
2. Remove oil seal rings from the center support. All service center support oil seal rings are hook type cast iron.
3. Using Clutch Spring Compressor, J-4670, and Rear Clutch Spring Compressor, J-6129, Figure 66, compress spring retainer and remove snap ring with Snap Ring Pliers, J-8059 or J-5586.
4. Remove spring retainer, six intermediate clutch release springs, and spring guide.
5. Remove intermediate clutch piston from center support.
6. Remove inner and outer seals from clutch piston.

**NOTE:** Do not remove the three screws retaining roller clutch inner race to center support.

## INSPECT CENTER SUPPORT

1. Inspect roller clutch inner race for scratches or indentations. Be sure lubrication hole is open.
2. Inspect bushing for scoring, wear or galling.

3. Check oil ring grooves for damage.
4. Air check oil passages to be sure they are open and not interconnected.
5. Inspect piston sealing surfaces for scratches.
6. Inspect piston seal grooves for nicks or other damage.
7. Inspect piston for cracks.
8. Inspect springs for collapsed coils or signs of distortion.
9. Inspect oil seal rings for damage.

**NOTE:** All service center support oil seal rings are hook type cast iron.

## ASSEMBLE CENTER SUPPORT AND INTERMEDIATE CLUTCH PISTON ASSEMBLY

1. Lubricate new inner and outer clutch piston seals with transmission fluid. Lubricate seal grooves in intermediate clutch piston and install seals with lips facing away from spring guide.
2. Place Intermediate Clutch Inner Seal Protector, J-21363, over center support hub and install intermediate clutch piston.
3. Install plastic spring guide.
4. Install six clutch release springs equally spaced into spring holes in spring guide.

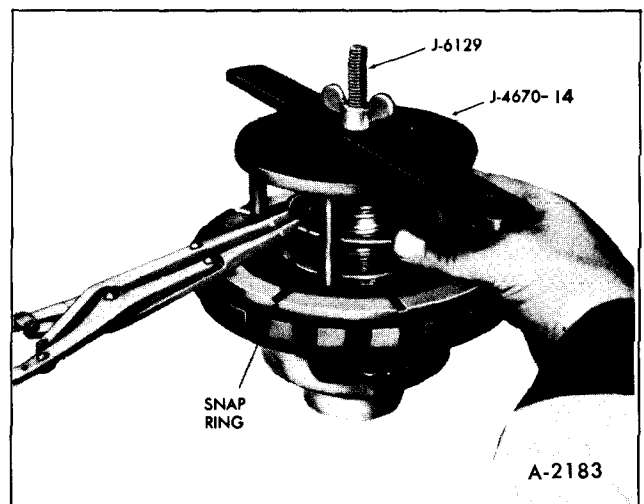

Figure 66—Removing Intermediate Clutch Retaining Snap Ring

5. Place spring retainer and snap ring over springs.

6. Using Clutch Spring Compressor, J-4670, and Rear Clutch Spring Compressor, J-6129, Figure 66, compress spring retainer, being careful that retainer does not get caught in snap ring groove, and install snap ring with Snap Ring Pliers. J-8059 or J-5586. Remove tools.

7. Install four oil seal rings on the center support.

8. Lubricate center support to reaction carrier thrust washer with petrolatum and install washer in recess of center support, Figure 67. Check to make sure sun gear thrust bearing race is on center support.

9. Install center support assembly into roller clutch in reaction carrier, Figure 68.

**NOTE:** With reaction carrier held, center support should turn clockwise only.

10. Install Gear Assembly Remover and Installer Adapter, J-21795, on end of main shaft so that tangs engage groove in shaft. Using Slide Hammer Handle, J-6125, and Speedometer Puller Bolt, J-21797, tighten bolt on tool to secure tool on shaft and prevent movement of the roller clutch during installation of the gear unit assembly, Figure 54.

## INSTALL REAR BAND AND COMPLETE GEAR UNIT ASSEMBLY

1. Inspect rear band for cracks or distortion and band ends for damage to anchor lugs and apply lug. Also inspect lining for cracks, flaking, burning and looseness.

2. Install rear band assembly in transmission case so that band lugs index with anchor pins.

3. Inspect support to case spacer for burrs or raised edges. If present, remove with a stone or fine sandpaper.

4. Install the support case spacer against the shoulder at the bottom of case splines and the gap located adjacent to the band anchor pin, Figure 69.

**CAUTION:** Do not confuse this spacer (.040" thick and both sides flat) with either the center support to case snap ring (one side beveled) or the intermediate clutch backing plate to case snap ring (.093" thick and both sides flat).

5. Install previously selected rear unit selective washer into slots provided inside rear of transmission case. Retain washer with petrolatum.

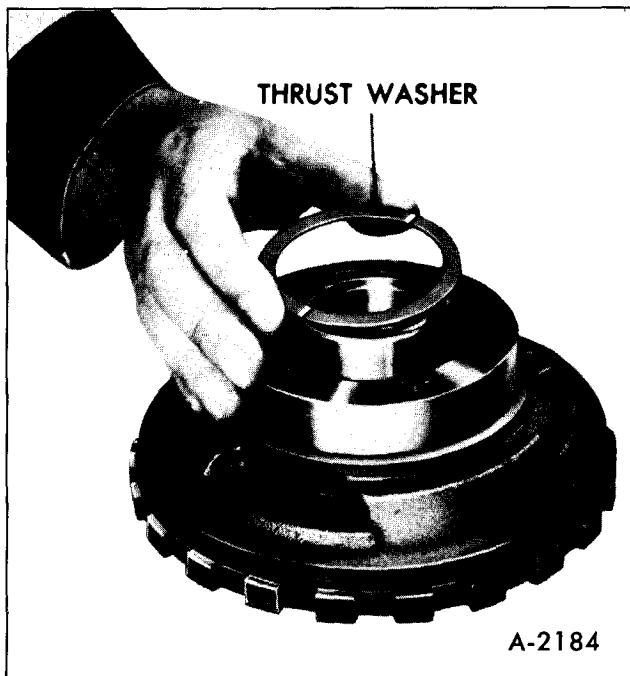

Figure 67—Center Support to Reaction Carrier Thrust Washer

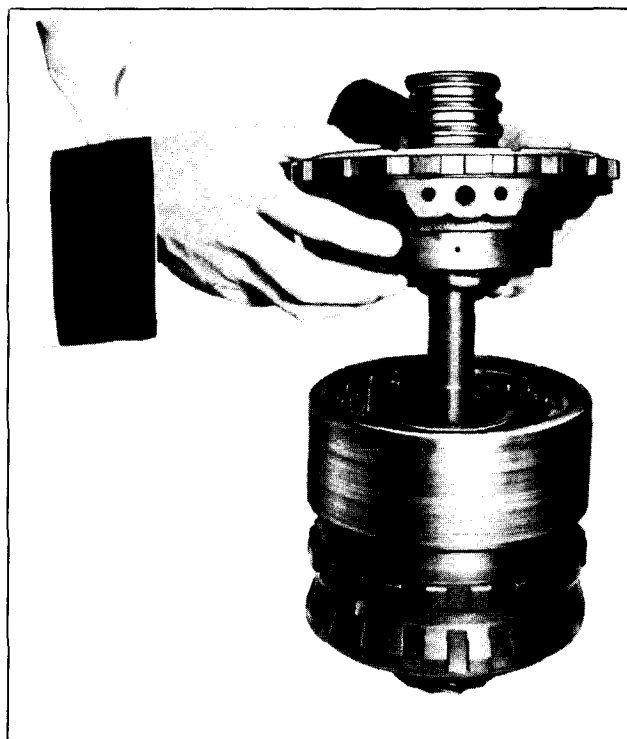

Figure 68—Center Support Installation



Figure 69—Installing Support-to-Case Spacer

**NOTE:** Proper washer size was determined at time of rear unit end play check.

6. Laying gear unit on its side, install metal thrust washer on output flange with bent tabs in tab pockets. Retain thrust washer with petrolatum.

**CAUTION:** *Be careful not to drop or bump gear unit assembly in transmission case during installation.*

7. Install gear unit, with center support and reaction carrier, by lining up center support bolt hole with hole in case and carefully guiding complete assembly into transmission case.

8. Lubricate center support to case snap ring with transmission fluid and install snap ring in transmission case with beveled side up, (flat side against center support) locating gap adjacent to front band anchor pin. Expand snap ring until center support is against shoulder of case.

9. Install case to center support bolt.

**NOTE:** To correctly perform this operation, it will be necessary to make the tool shown in Figure 70. Then follow procedure outlined below:

Place center support locating tool into the case direct clutch passage, with the handle of the tool pointing to the left, as viewed from the front of transmission and parallel to the bell housing mounting, Figure 71.

Lift upward on the tool which will tend to rotate the center support counterclockwise as viewed from the front of transmission. While holding the center

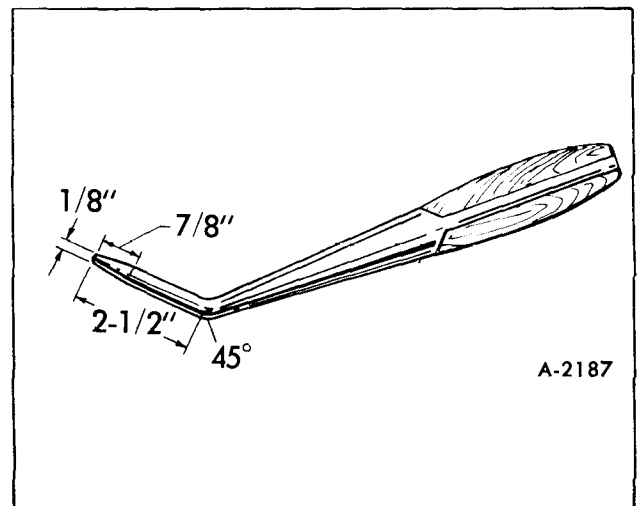

Figure 70—Center Support Locating Tool

support firmly counterclockwise against case splines, torque case to center support bolt to 23 ft. lbs., using a 3/8" 12-point thin-wall deep socket.

**CAUTION:** *When using the locating tool, care should be taken not to raise burrs on the case valve mounting face.*

10. Before installing intermediate clutch plates, inspect plates for signs of burning, scoring, and wear.

11. Lubricate three steel and three composition intermediate clutch plates with transmission fluid and install clutch plates in transmission case, Figure 72. Start with steel plate and alternate composition and steel plates.

12. Install intermediate clutch backing plate with flat machine surface against clutch plates.

13. Install backing plate to case snap ring with

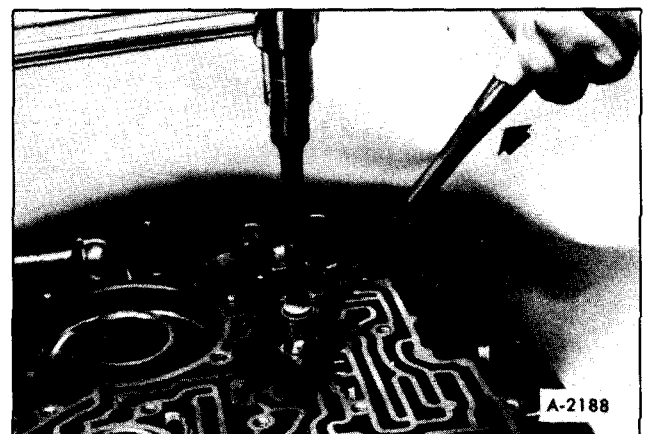

Figure 71—Locating Center Support

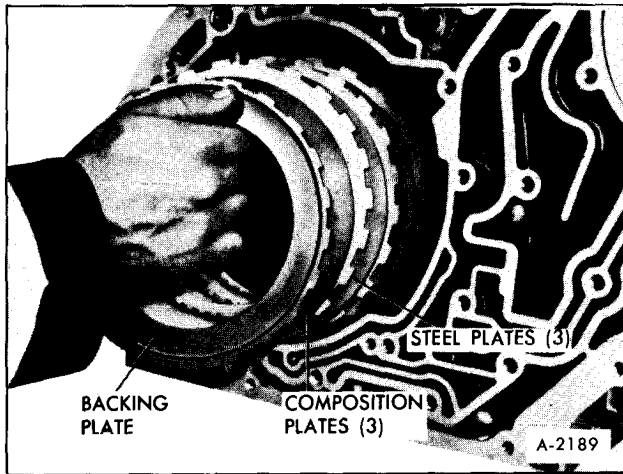

Figure 72—Installing Intermediate Clutch

snap ring gap on side of case opposite front band anchor pin.

**NOTE:** Both sides of this snap ring are flat, and it is approximately .093" thick.

14. Air check operation of intermediate clutch piston. Apply air through center oil feed hole to actuate clutch piston.

15. Recheck rear unit end play as described previously.

## DIRECT CLUTCH AND INTERMEDIATE SPRAG ASSEMBLY (FIGURE 73)

### DISASSEMBLY

1. Remove sprag retainer snap ring, and remove clutch retainer.

2. Remove sprag outer race and bushings, and remove sprag assembly from outer race.

3. Turn unit over and remove direct clutch backing plate to clutch housing snap ring.

4. Remove direct clutch backing plate and six composition and six steel clutch plates.

5. Using Clutch Spring Compressor, J-4670, Rear Clutch Spring Compressor, J-6129, or an arbor press, and Adapter, J-21664, compress spring retainer and remove snap ring with Snap Ring Pliers, J-8059 or J-5586.

6. Remove tools, spring retainers, and clutch release springs.

7. Remove direct clutch piston from direct clutch housing.

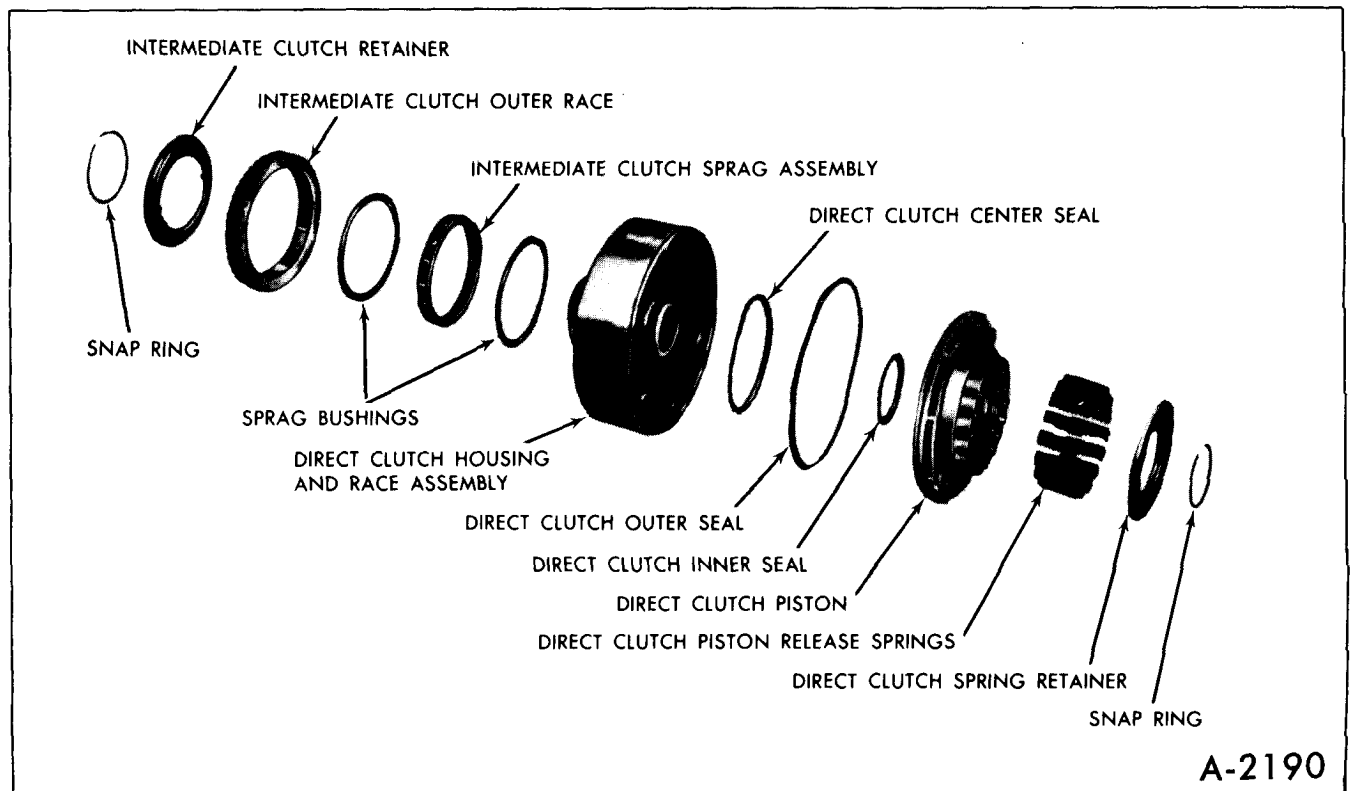

Figure 73—Direct Clutch and Piston

8. Remove inner and outer seals from clutch piston.

9. Remove center piston seal from direct clutch housing.

## INSPECTION

1. Inspect sprag assembly for popped or loose sprags.

2. Inspect sprag bushing for wear or distortion.

3. Inspect inner and outer races for scratches or wear.

4. Inspect clutch housing for cracks, wear, proper openings of oil passages and wear on clutch plate drive lugs.

5. Inspect composition faced and steel clutch plates for sign of wear or burning.

6. Inspect backing plate for scratches or other damage.

7. Inspect piston for cracks and free operation of ball check.

8. Inspect springs for collapsed coils or signs of distortion.

**NOTE:** The 14 direct clutch release springs are not serviced individually. If one or more of these springs require replacement, discard all of them and install the 16 service direct clutch release springs.

## ASSEMBLY

1. Lubricate new inner and outer clutch piston seals with transmission fluid. Lubricate seal grooves in direct clutch piston and install seals with lips facing away from spring pockets.

**NOTE:** Make certain piston has ball check.

2. Lubricate new center seal with transmission fluid. Lubricate seal groove in direct clutch housing and install seal in clutch housing with lip facing up.

3. Place Forward and Direct Clutch Inner Seal Protector, J-21362, over direct clutch hub. Install clutch piston inside Forward and Direct Clutch Piston Installer, J-21409, insert assembly in direct

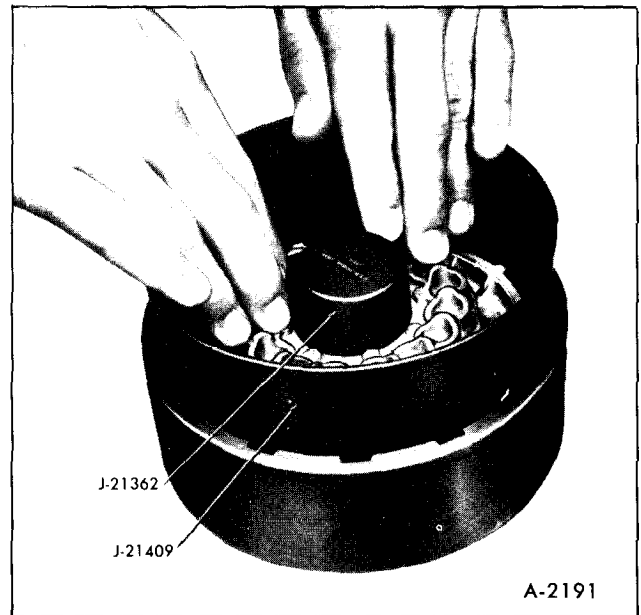

Figure 74—Installing Direct Clutch Piston

clutch housing Figure 74 and install clutch piston by rotating it slightly, in a clockwise direction.

4. Install 16 clutch release springs into spring pockets in clutch piston.

5. Place spring retainer and snap ring over springs.

6. Using Clutch Spring Compressor, J-4670, Rear Clutch Spring Compressor, J-6129, or an arbor press, and Adapter, J-21664, compress spring retainer, being careful that retainer does not get caught in snap ring groove, and install snap ring with Snap Ring Pliers, J-8059 or J-5586. Remove tools.

**NOTE:** Make certain clutch release springs are not leaning. If necessary, straighten springs with a small screwdriver.

7. Lubricate the five flat and one waved (plate with "U" notch) and steel and six composition clutch plates with transmission fluid and install clutch plates in direct clutch housing. Start with waved steel plate and alternate composition and flat steel clutch plates.

8. Install direct clutch backing plate over clutch plates and install backing plate snap ring.

9. Invert clutch housing and install one sprag bushing, cup side up, around sprag inner race.

10. Install sprag assembly into clutch outer race.

11. With ridge on inner cage of sprag facing up

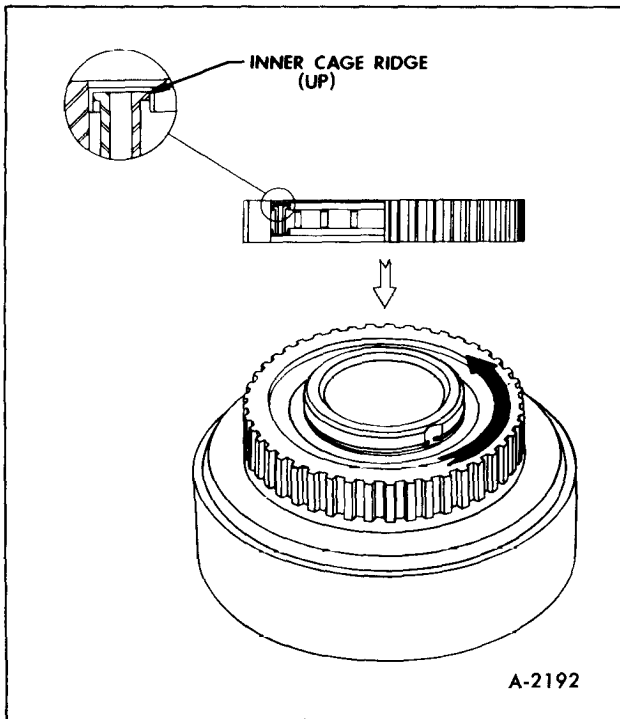

Figure 75—Sprag Rotation

install sprag and outer race on inner race with counterclockwise turning motion.

**NOTE:** When installed, outer race should turn only counterclockwise, Figure 75.

12. Install sprag bushing, cup side down, over sprag assembly.

13. Install sprag retainer and snap ring.

## INSTALL FRONT BAND AND DIRECT CLUTCH ASSEMBLY

1. Inspect front band for cracks or distortion and band ends for damage at anchor lug and apply lug. Also inspect lining for cracks, flaking, burning, and looseness.

2. Install front band with band anchor hole over band anchor pin, and apply lug facing servo hole, Figure 76.

3. Install direct clutch housing and intermediate sprag assembly. Make certain that clutch housing hub bottoms on sun gear shaft and splines on forward end of sun gear shaft are flush with splines in direct clutch housing.

**NOTE:** It will be necessary to rotate clutch hous-

ing to allow sprag outer race to index with intermediate composition clutch plates. Removal of direct clutch composition-faced and steel plates may be helpful, and applying air pressure through the center support screw to apply the intermediate clutch plates may facilitate assembly.

4. Check operation of direct clutch by applying air pressure through direct clutch passage next to center support bolt.

## FORWARD CLUTCH ASSEMBLY DISASSEMBLY (FIGURE 77)

1. Remove forward clutch housing to direct clutch hub snap ring.

2. Remove direct clutch hub.

3. Remove forward clutch hub and one thrust washer from inner side of hub.

4. Remove five composition and five flat and one dished steel clutch plates.

5. Using Clutch Spring Compressor, J-4670, and Adapter, J-21664, compress spring retainer with arbor press and remove snap ring using Snap Ring Pliers, J-8059 or J-5586.

6. Remove tools, spring retainer and 16 clutch release springs. Keep springs separate from direct clutch springs.

7. Remove forward clutch piston from forward clutch housing.

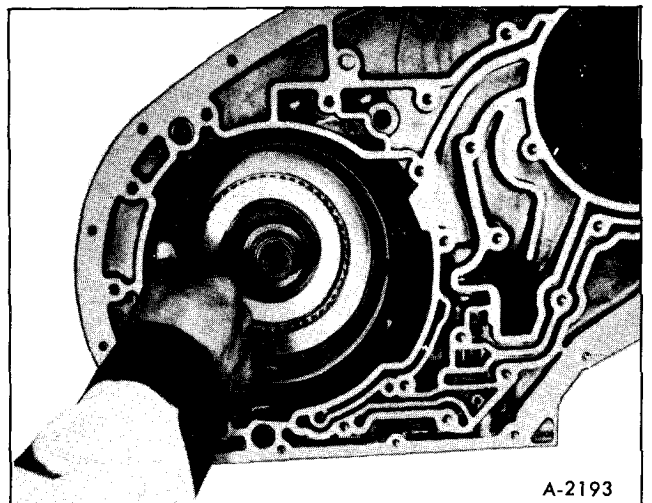

Figure 76—Front Band Installation

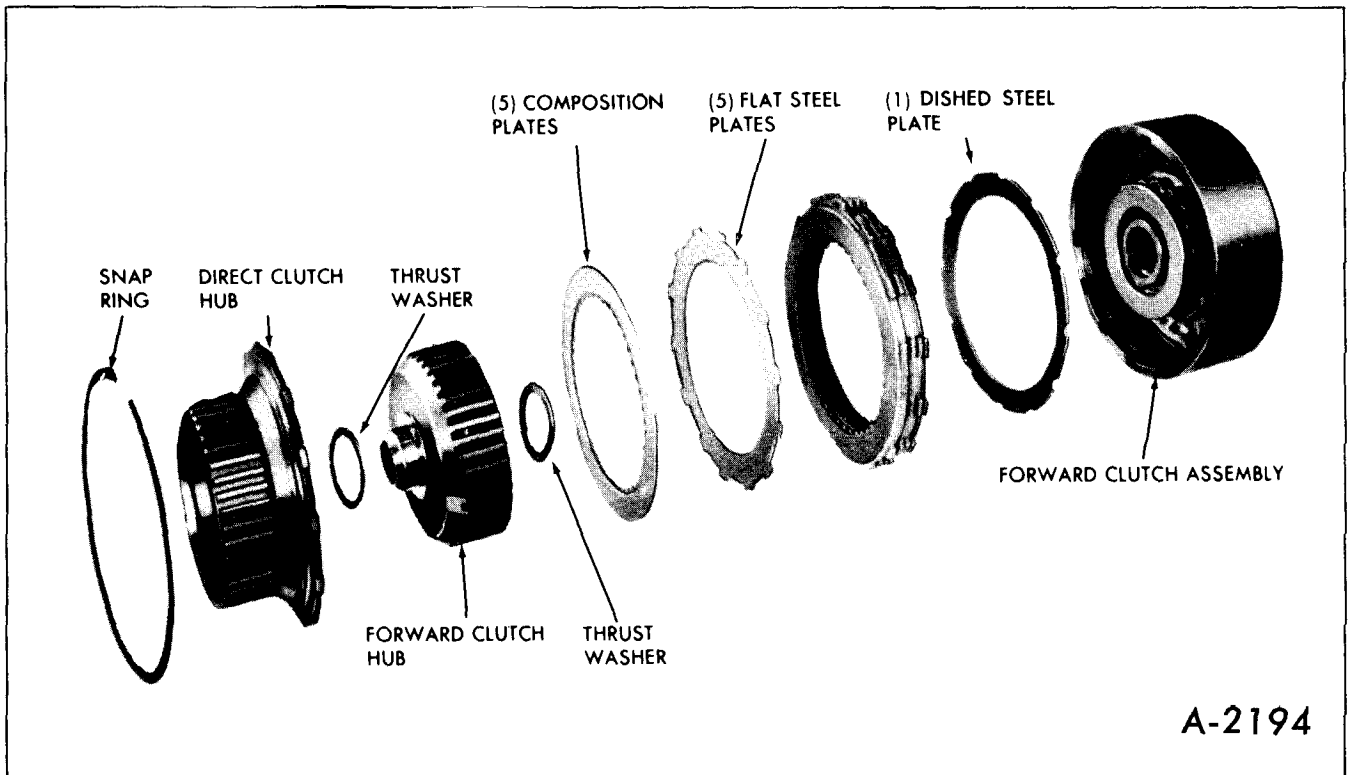

Figure 77—Forward Clutch Components

8. Remove inner and outer seals from clutch piston.

9. Remove center piston seal from forward clutch housing.

## INSPECTION

1. Inspect composition-faced and steel clutch plates for signs of burning, scoring or wear.

2. Inspect release springs for collapsed coils or signs of distortion.

3. Inspect clutch hubs for worn splines, proper lubrication holes, and thrust faces.

4. Inspect piston for cracks.

5. Inspect clutch housing for wear, scoring, cracks and open oil passages.

## ASSEMBLY (FIGURE 78)

1. Lubricate new inner and outer clutch piston seals with transmission fluid. Lubricate seal grooves

in forward clutch piston with petrolatum and install seals with lips facing away from spring pockets.

**NOTE:** The forward and direct clutch pistons have identical inside and outside diameters. Therefore, extreme care should be exercised during reassembly to assure the proper piston be installed in the clutch assemblies. The forward clutch piston can be identified by the absence of a check ball in the clutch apply face of the piston.

2. Lubricate new center piston seal with transmission fluid. Lubricate seal groove in forward clutch housing with petrolatum and install seal into clutch housing with lip facing up.

3. Place Forward and Direct Clutch Inner Seal Protector, J-21362, over forward clutch hub. Install clutch piston inside Forward and Direct Clutch Piston Installer, J-21409, insert assembly in forward clutch housing, and install clutch piston by rotating it slightly in a clockwise direction until seated.

4. Install sixteen clutch release springs into spring pockets in clutch piston.

5. Using Clutch Spring Compressor, J-4670, and Adapter, J-21664, compress spring retainer with arbor press, being careful that retainer does not catch in snap ring groove, and install snap ring using Snap Ring Pliers, J-8059 or J-5586, and remove tools.

A-2194

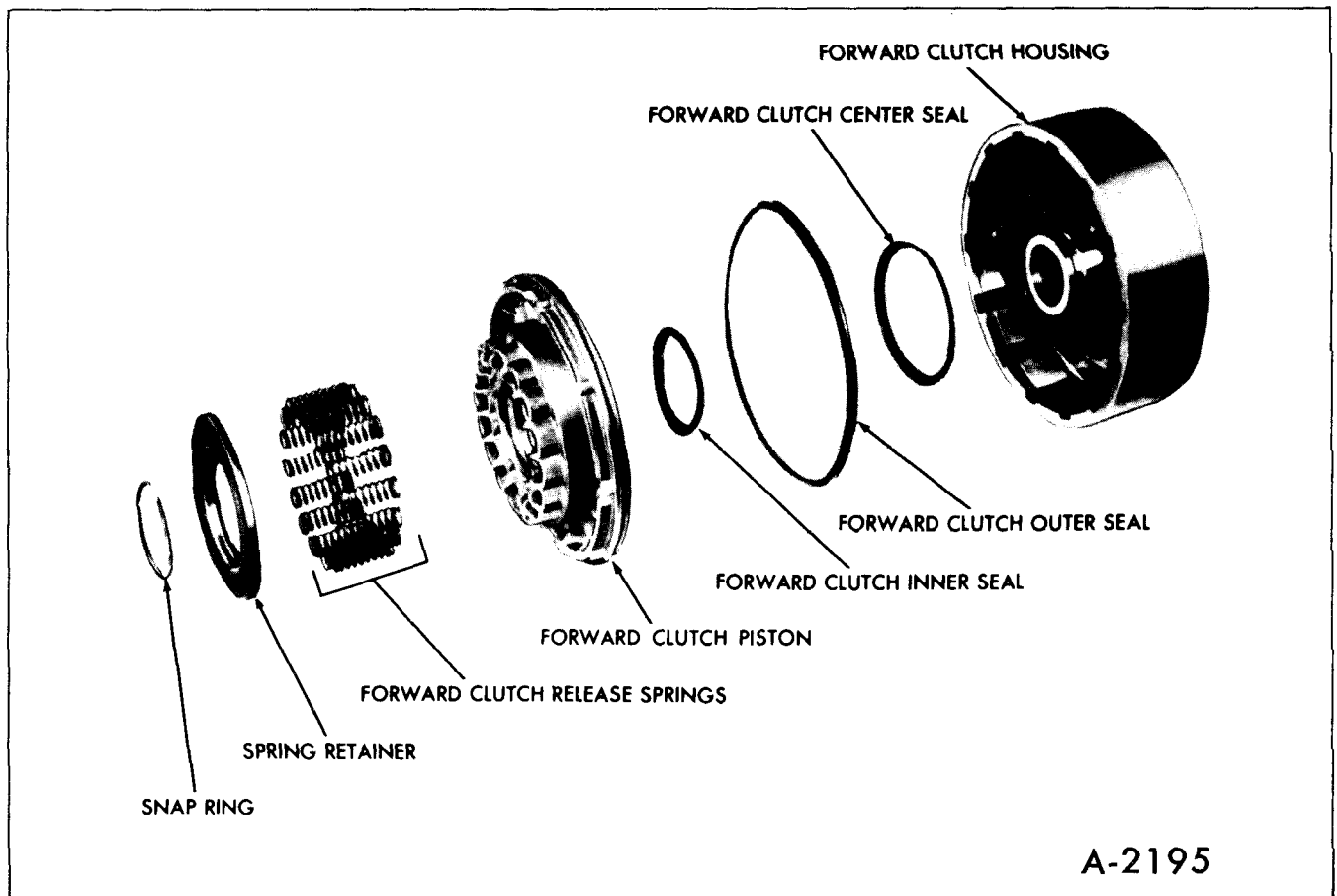

A-2195

Figure 78—Forward Clutch Piston Components

**CAUTION:** Make certain clutch release springs are not leaning. If necessary, straighten with a small screwdriver.

6. Remove forward clutch assembly from arbor press and place on work bench.

7. Install the forward clutch hub thrust washers on the forward clutch hub. Retain with petrolatum.

8. Install forward clutch hub in forward clutch housing.

9. Lubricate the dished and five flat steel and five composition clutch plates with transmission fluid and install clutch plates in forward clutch housing. Start with dished steel plate (O.D. up) and place a flat steel plate on top of the dished steel plate. Then alternate composition and flat steel clutch plates.

10. Install direct clutch hub in forward clutch housing over clutch plates, and install snap ring.

11. Air check forward clutch and piston operation, Figure 79.

## INSTALL FORWARD CLUTCH

1. Install Front Unit End Play Checking Tool, J-22241 into forward clutch, Figure 45.

2. Install forward clutch assembly into transmission, making certain main shaft goes into forward

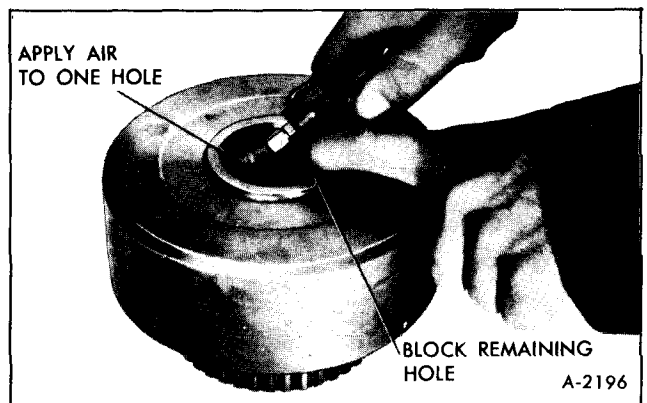

Figure 79—Air Check Forward Clutch Piston



clutch hub. It will be necessary to rotate clutch housing to allow direct clutch driving hub to index with direct clutch composition-faced plates.

3. Remove Front Unit End Play Checking Tool, J-22241.

## INSTALL PUMP COVER PLATE

1. Install new pump cover plate gasket on transmission.

2. Install pump cover plate on transmission and install attaching bolts per bolt chart, Figure 80.

**NOTE:** Do not install pump attaching bolts (F) or single bolt (E) in pump cover plate at this time.

3. Using the driven sprocket as a driver rotate the forward clutch.

**NOTE:** If the forward clutch housing cannot be rotated as the pump cover plate is being pulled into place, the forward or direct clutch housings have not been properly installed to index with all the clutch plates. This condition must be corrected before the pump cover plate is pulled fully into place.

4. Torque all bolts to 20 foot-pounds.

5. Repeat front unit end play check as described.

6. Install remaining bolt (E) in driven support housing, tightening to 20 foot-pounds.

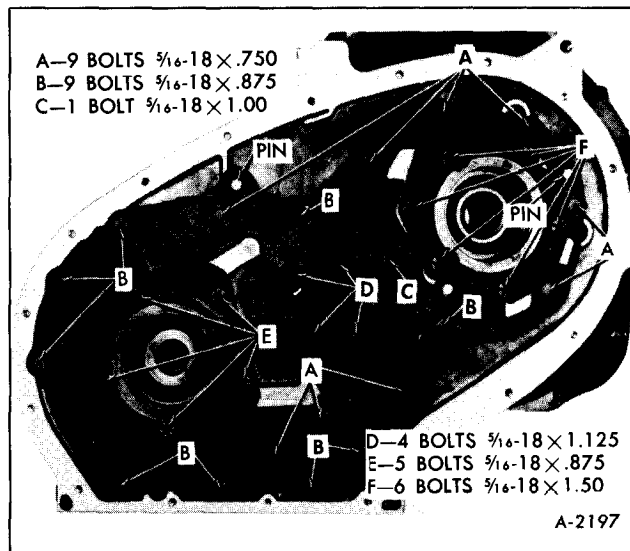

Figure 80-Pump Cover Plate Screws

## OIL PUMP

### DISASSEMBLY

1. Mark drive and driven gears for reassembly in same position and remove the pump body.

**NOTE:** Installing the gears in the same position as removed will assure the quietest operation, as the gear teeth will mesh in the established wear pattern.

2. Remove drive and driven gears from pump body.

3. Remove and discard pump body to case square-cut O-ring seal.

### INSPECTION

1. Using tip of finger, inspect gear pocket and crescent for nicks, burrs, scoring or galling.

2. Inspect drive gear for nicks, burrs, scoring, or galling.

3. Inspect driven gear for nicks, burrs, scoring, or galling.

4. Place pump gears in pump body and check pump body face to gear face clearance. Clearance should be .0013"-.0035".

5. Check face of pump body for nicks, burrs, scoring, or galling.

6. Check pump body face flatness. Overall flatness should be .000" to .002".

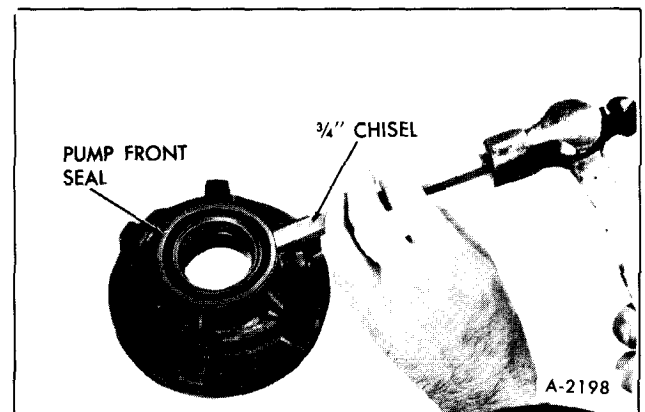

Figure 81-Removing Pump Front Seal

7. Inspect bushing for nicks, burrs, scoring, galling, out-of-round, or excessive wear.

**NOTE:** To check for out-of-round, install pump body on the converter hub and look for eccentricity between pump bushing and converter hub.

8. Check for damaged pump cover plate bolt holes.

9. Inspect front seal for damage. If replacement of front seal is necessary, use a standard 3/4" cold chisel and pry front seal from pump body, Figure 81.

## ASSEMBLY

1. If necessary, install a new front seal, using Pump Oil Seal Installer, J-21359, to drive seal into place. Use a non-hardening sealer on outside of seal before installing into pump, Figure 82.

2. Install new pump to case square-cut O-ring seal.

3. Install driven gear into pump body with alignment mark up.

4. Install drive gear into pump body with drive tangs up, Figure 83.

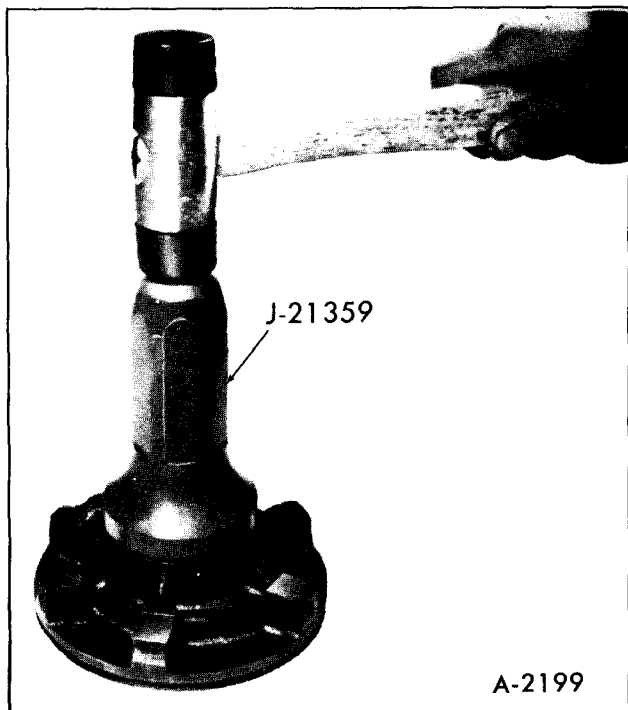

Figure 82—Installing Pump Front Seal

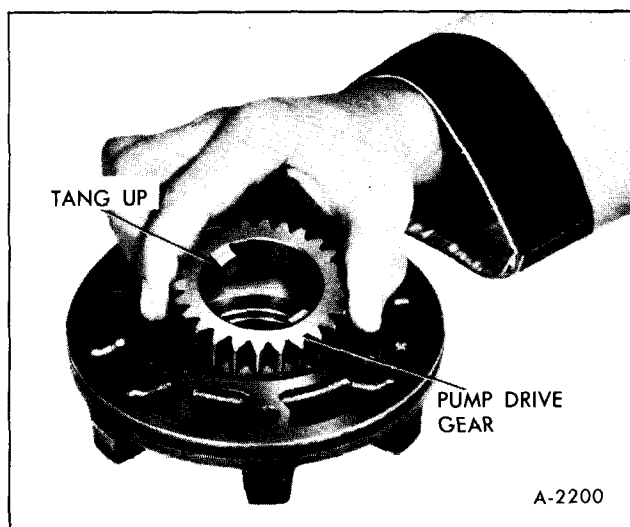

Figure 83—Installing Pump Drive Gear

**NOTE:** Drive gear should always be installed with counterbore down.

## INSTALLATION

1. Rotate transmission in holding fixture base so that cored oil passages are up.

2. Install pump assembly over stator shaft and position to drive support housing, rotating pump as necessary to align holes in pump cover plate with pump attaching bolt holes.

3. Install six retaining bolts (F), finger tight, Figure 80.

4. Tighten pump attaching bolts to 20 ft. lbs.

## INSTALL SPROCKETS, LINK ASSEMBLY AND SPROCKET COVER

1. Place link belt around the drive and driven sprockets so that the links engage the teeth of the sprockets, colored guide link which has etched numerals facing link cover.

2. Simultaneously place link belt, drive and driven sprockets into support housing.

3. Using a plastic mallet, gently seat the sprocket bearing assemblies into the support housings.

4. Install sprocket assembly to support housing snap rings using J-4646 snap ring pliers.

5. Install new case to cover and plate assembly sprocket housing gasket.

6. Install sprocket housing cover and plate assembly and eighteen attaching bolts. Torque bolts to 8 ft. lbs.

**NOTE:** One sprocket cover housing attaching bolt is 1/4 inch longer. This bolt must be installed in the tapped hole located directly over the cooler fittings on the transmission case.

## DETENT LEVER, MANUAL SHAFT, PARKING LINKAGE, REAR SERVO, FRONT SERVO, CHECK BALLS, AND CONTROL VALVE SPACER

### INSPECT DETENT LEVER, MANUAL SHAFT, AND PARKING LINKAGE

1. Inspect parking actuator rod for cracks, or broken spring retainer lugs.
2. Inspect actuator spring for damage.
3. Inspect actuator for a free fit on actuator rod.
4. Inspect parking pawl for cracks or wear.
5. Inspect manual shaft for damaged threads.
6. Inspect inside detent lever for cracks or a loose pin.
7. Inspect parking pawl return spring for deformed coils or ends.
8. Inspect parking bracket for cracks or wear.
9. Inspect detent spring and roller assembly.

### INSTALL DETENT LEVER, MANUAL SHAFT AND PARKING LINKAGE

1. Install parking pawl (tooth toward inside of case), pawl return spring and parking pawl shaft into case, Figure 84.

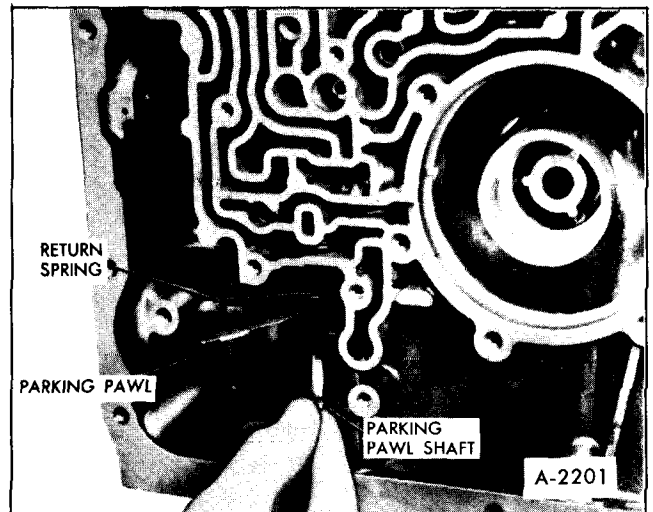

Figure 84—Installing Parking Pawl

2. Install parking pawl shaft retaining pin into case hole.
3. Install parking bracket into case, tightening attaching screws to 18 ft. lbs.
4. Install a new manual shaft O-ring seal on manual shaft.
5. Install the actuator rod plunger under the parking bracket and over the parking pawl and through hole in detent lever. Position detent lever in transmission case.
6. Install the manual shaft assembly through the retaining lock nut on manual shaft, Figure 85.
7. Install manual shaft retaining pin into case, long smooth end first.
8. Torque lock nut to 18 ft. lbs.

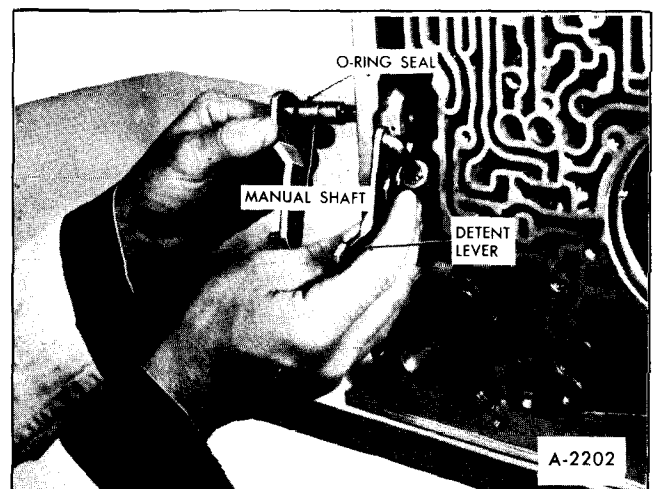

Figure 85—Installing Manual Shaft

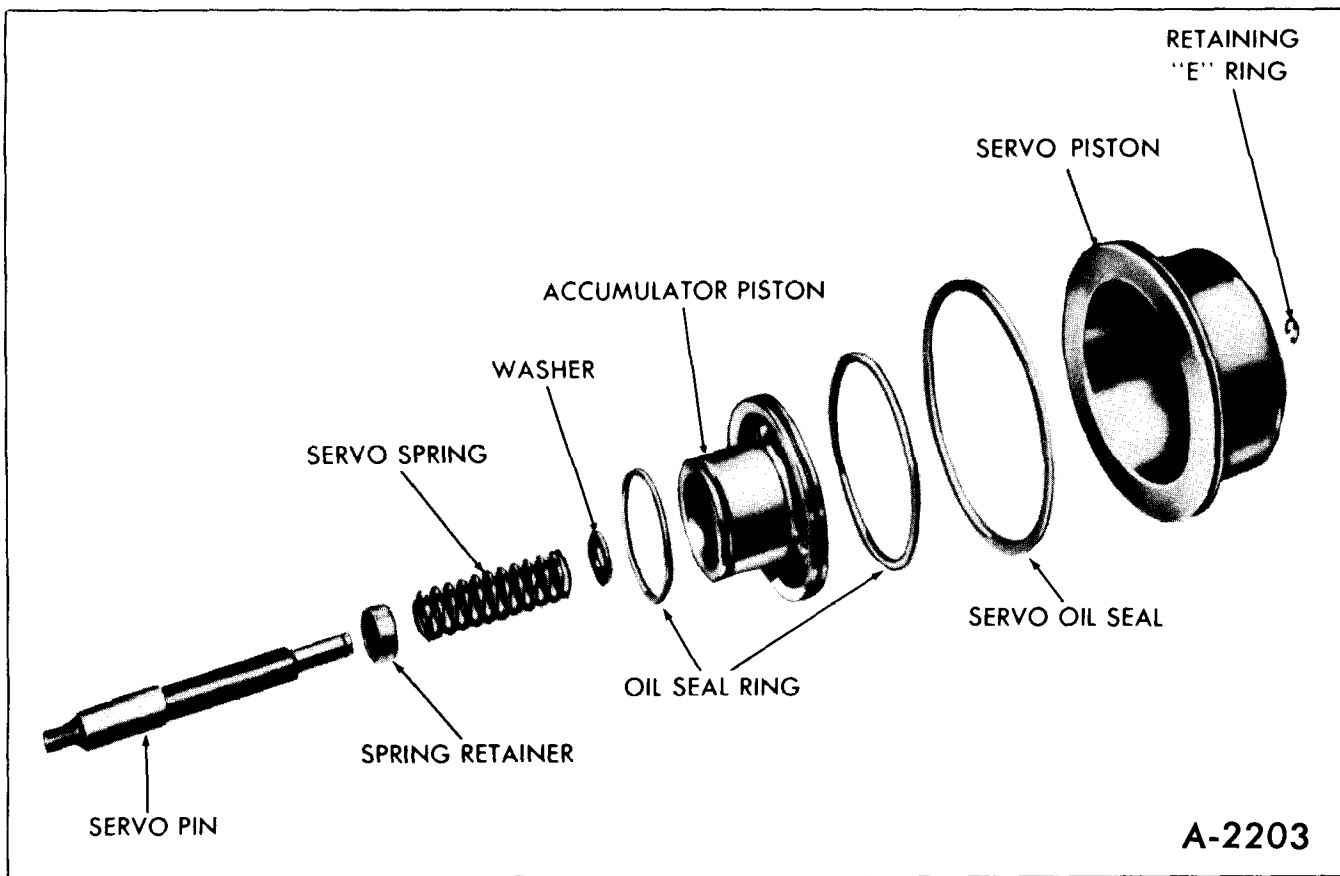

Figure 86—Rear Servo and Accumulator

### DISASSEMBLE REAR SERVO ASSEMBLY (FIGURE 86)

1. Remove rear accumulator piston from rear servo piston.
2. Remove E-ring retaining rear servo piston to band apply pin.
3. Remove rear servo piston and seal from band apply pin.
4. Remove washer, spring and retainer.

### INSPECT REAR SERVO

1. Check freeness of oil seal rings in accumulator piston grooves.

**NOTE:** Do not remove the teflon oil seal rings from the rear accumulator piston, unless the oil seal rings require replacement.

If the teflon inner oil seal ring. (small diameter) requires replacement, for service, use the aluminum oil seal ring.

The rear accumulator piston, large diameter ring groove depth, is machined shallower to take the large teflon oil seal ring; if this requires replacement, use only the teflon oil seal ring.

2. Inspect fit of band apply pin in servo piston.
3. Inspect band apply pin for scores or cracks.
4. Inspect band apply pin for proper size as determined by pin selection check.

### ASSEMBLE REAR SERVO

1. Install spring retainer, cup side first, servo pin spring and washer on servo pin.
2. Install servo piston on pin and secure with E-ring retainer.

3. If removed, install oil seal ring on servo piston.
4. If removed, install inner and outer oil rings on accumulator piston.
5. Install accumulator piston into bore of servo piston.

## INSTALL REAR SERVO

**NOTE:** If the transmission is in the vehicle, a sheet metal bracket will be required to hold the rear servo assembly, front servo assembly, check balls, valve body to spacer plate gasket and valve body spacer plate, until the control valve assembly is installed. See Figure 87.

1. Lubricate inner and outer rear servo bores in transmission case with transmission fluid and install rear accumulator spring in servo inner bore.

**NOTE:** Before installing rear servo assembly, make certain that rear band apply lug is aligned with servo pin bore in transmission case. Otherwise servo pin will not apply band.

2. Position rear servo assembly in transmission case bore.
3. Press down on rear servo assembly, making certain oil seal ring is properly seated in case bore.

## INSPECT FRONT SERVO

**NOTE:** See Figure 88. Do not remove the teflon

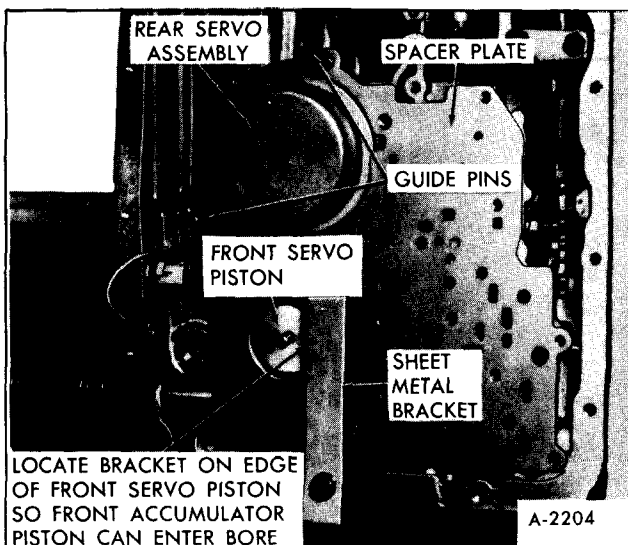

Figure 87—Spacer Plate Holding Bracket

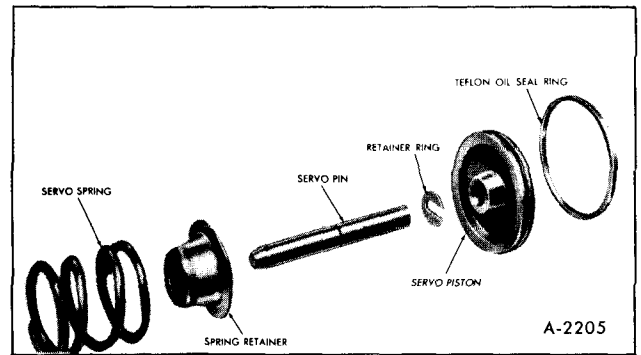

Figure 88—Front Servo Components

oil seal ring from the front accumulator piston unless the oil seal ring requires replacement. For service, the oil seal ring will be cast iron.

1. Inspect servo pin for damage.
2. Inspect piston oil ring for damage.
3. Inspect piston for cracks or porosity.
4. Check fit of servo pin in piston and case.

## INSTALL FRONT SERVO ASSEMBLY

Reassemble parts of front servo, making sure tapered end of servo pin is pointed through the spring and spring retainer, and install in bore in case. Make sure the retainer ring is installed in the servo pin groove.

**NOTE:** The teflon ring allows the front servo piston to slide very freely in the case. The free fit of the ring in the bore is a normal characteristic and does not indicate leakage during operation. The teflon ring should only be replaced if it shows damage or if evidence of leakage during operation exists.

## INSTALL CHECK BALLS AND CONTROL VALVE SPACER

1. Install seven check balls in cored passages, Figure 89. (Use petrolatum to retain balls in case.)

**NOTE:** If transmission is in vehicle, place check balls into ball seat pockets on spacer plate.

2. Install valve body spacer to case gasket on transmission case.

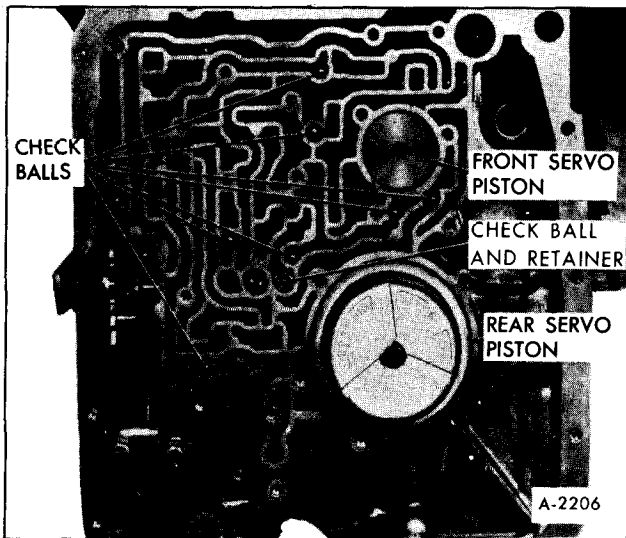

Figure 89—Check Ball Location

3. Install valve body spacer on transmission.

**NOTE:** Valve body spacer to case gasket should extend approximately 1/8 inch beyond the spacer plate, over the void case channel, Figure 90. If service gaskets are being installed, the valve body spacer to case gasket has an extension which will cover the void case channel.

4. Install valve body to spacer gasket.
5. Install guide pins.

## CONTROL VALVE ASSEMBLY (FIGURE 91)

### DISASSEMBLY

When disassembling control valve, make certain that springs are accurately identified so that they can be properly reassembled.

1. Position control valve assembly with cored face down.
2. Remove two screws securing detent solenoid to control valve body and remove downshift solenoid and gasket.
3. Position control valve assembly with cored face up and accumulator pocket on bottom.
4. Remove manual valve from upper bore.
5. Install Control Valve Accumulator Piston In-

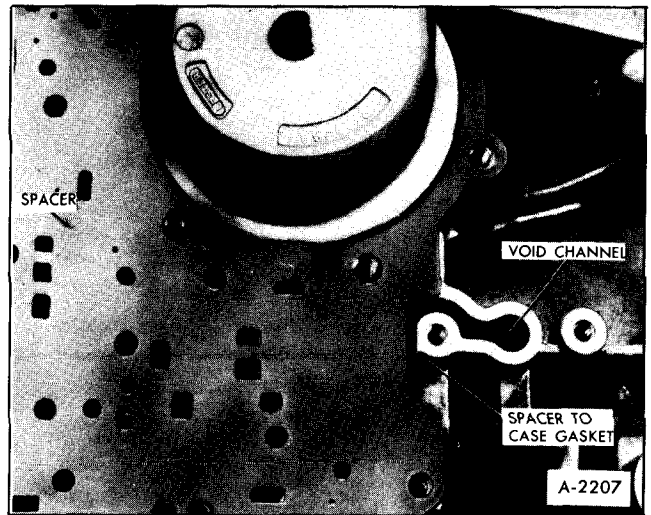

Figure 90—Valve Body Spacer-to-Case Gasket

staller, J-21885, on accumulator piston, compress piston and remove E-ring retainer, Figure 92.

6. Remove Installer, J-21885, and remove accumulator piston and spring.
7. Using pin punch, remove retaining pin from lower left bore, pressing on pin from outer side of valve body. Remove 2-3 modulator bushing, 2-3 shift valve spring, 2-3 modulator valve, 3-2 intermediate spring and 2-3 shift valve from left bore.

**NOTE:** 2-3 modulator valve will be inside of 2-3 modulator bushing.

8. Using pin punch, remove retaining pin from lower center left bore, pressing on pin from outer side of valve body. Remove 1-2 modulator bushing, 1-2 modulator spring, 1-2 modulator valve and 1-2 shift valve from lower left center bore.

**NOTE:** 1-2 regulator valve and spring and 1-2 detent valve may be inside of 1-2 modulator bushing.

9. Using pin punch, remove retainer pin from upper left center bore by pressing on outer side of valve body.

**WARNING: HOLD HAND OVER BORE WHEN REMOVING RETAINER PIN AS DETENT REGULATOR VALVE SPRING MAY FORCE OTHER COMPONENTS OUT OF BORE.**

10. Remove bore plug, detent valve, detent regulator valve, spacer and detent regulator valve spring from upper left center bore.
11. Remove retaining pin from bottom bore on left side by prying out with a pair of long nose pliers.

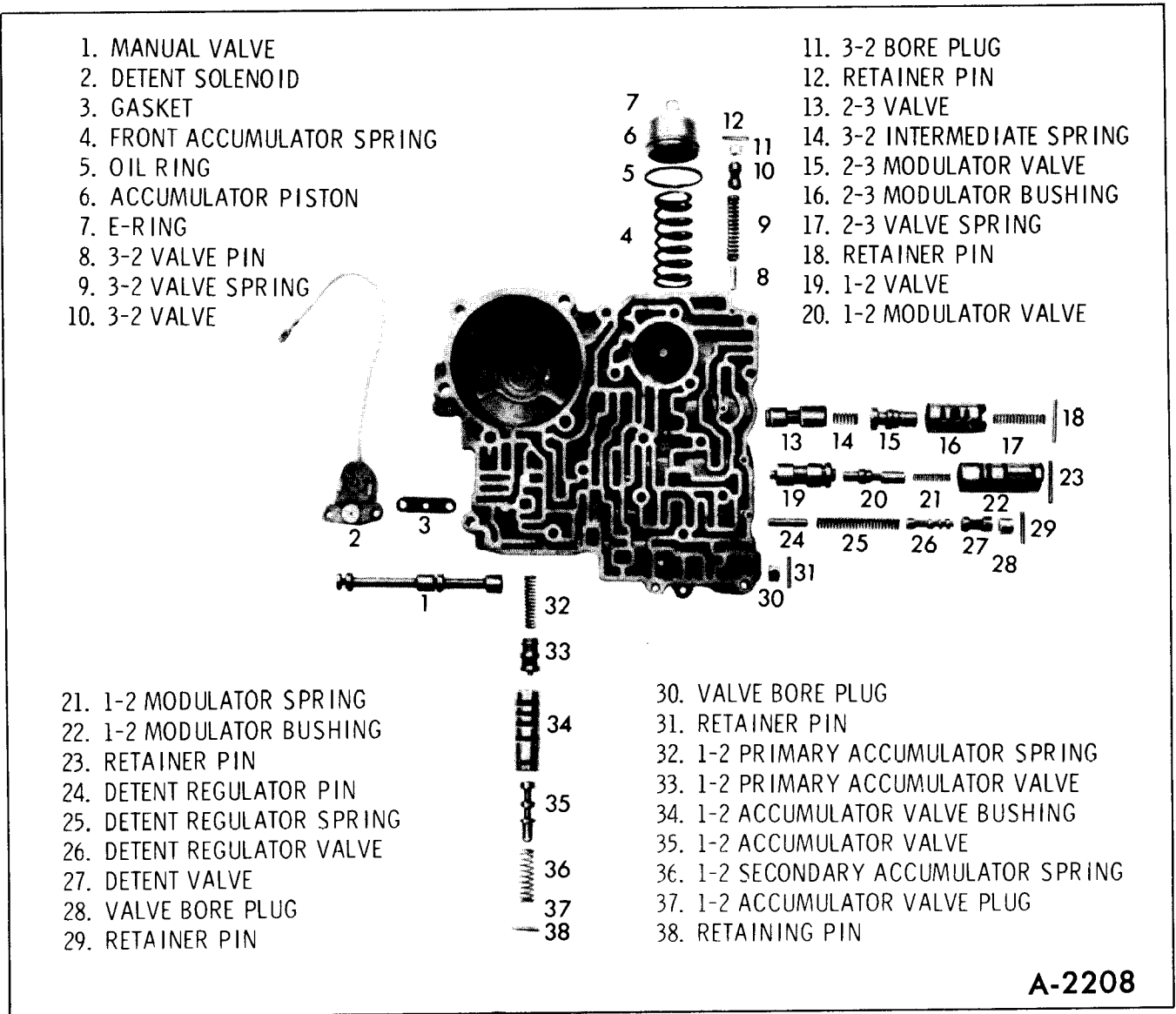

Figure 91-Control Valve

**WARNING: HOLD HAND OVER BORE WHEN REMOVING RETAINER PIN AS 3-2 VALVE SPRING MAY FORCE BORE PLUG OUT.**

12. Remove bore plug, 3-2 valve, spring and spacer from bottom left bore.

13. Remove retaining pin from top bore by prying out with long nose pliers from outer side of valve body.

**WARNING: HOLD HAND OVER BORE WHEN REMOVING RETAINER PIN AS ACCUMULATOR SPRINGS MAY FORCE OTHER COMPONENTS OUT OF BORE.**

14. Remove bore plug, 1-2 accumulator valve

bushing, 1-2 accumulator valve and secondary spring, 1-2 accumulator primary valve and spring.

**INSPECTION**

**NOTE:** Do not remove the teflon oil seal ring from the front accumulator piston unless the oil seal ring requires replacement. For service, the oil seal ring will be aluminum.

1. Wash control valve body, valves, and other parts in clean solvent.

**CAUTION:** Do not allow valves to bump

A-2208

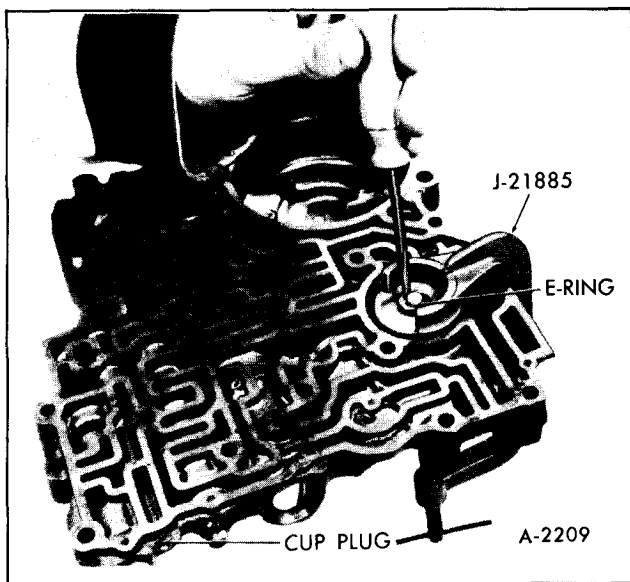

Figure 92—Removing Front Accumulator

*together, as this might cause nicks and burrs.*

2. Inspect all valves and bushings carefully to make sure that they are free from dirt and are not damaged in any respect. If burrs are present, they should be removed with a fine stone or fine grade of crocus cloth and light oil. Be careful not to round off shoulders of valves.

3. All valves and bushings should be tested in their individual bores to make certain that free movement can be obtained. All valves should fall freely of their own weight with a slight tapping action on the body. In checking be careful to prevent valve damage in any way.

4. The manual valve is the only valve that can be serviced separately. If other valves are defective or damaged beyond repair, a new control valve assembly should be installed.

5. Inspect body for cracks or scored bores.

6. Check all springs for distortion or collapsed coils.

7. Inspect piston and oil ring for damage.

## ASSEMBLY (FIGURE 91)

1. Position control valve body and cored face up and accumulator pocket on bottom.

2. Install the 1-2 primary accumulator spring

into the 1-2 primary accumulator valve and install both, spring first, into top bore, using a retainer pin to temporarily hold valves and spring in their operating position.

3. Install the 1-2 accumulator valve, wide land first, into the 1-2 accumulator bushing.

4. Install the 1-2 accumulator valve bushing into the top bore, aligning the square port on the end of the bushing with hole for retaining pin.

5. Install the 1-2 secondary accumulator spring and the 1-2 bore plug into bushing.

6. Compress 1-2 accumulator valve train, install grooved retaining pin, grooved end entering hole last from outer side of valve body, pressing pin flush with valve body. Remove the temporary retaining pin.

7. Insert spacer inside of 3-2 valve spring and install spring and spacer in bottom left bore.

8. Install 3-2 valve in bottom left bore.

9. Compressing 3-2 valve spring, install bore plug, hole end out, and secure with grooved retaining pin from cored side of valve body.

10. Insert spacer inside of detent regulator valve spring and install spring and spacer into upper left center bore, making certain spring seats in bottom of bore.

11. Compress detent regulator valve spring and hold with a small screwdriver placed between end of spring and wall on cored side of valve body.

12. Install detent regulator valve, stem end out, and detent valve, small land first, into upper left center bore.

13. Insert bore plug, hole out, into upper left center bore and, pressing inward on bore plug, remove screwdriver and install remaining pin from cored side of valve body.

14. Install 1-2 shift valve, longer stem end first, in lower left center bore, making certain valve seats in bottom of bore.

15. Install 1-2 regulator valve and spring and 1-2 detent valve into 1-2 modulator bushing. Install assembly into lower left center bore of control valve body, open end of bushing first.

16. Compress bushing against spring and secure with retaining pin from cored side of control valve body.

17. Install 3-2 intermediate spring in open end of



2-3 shift valve, and install valve and spring, valve first, into lower left bore. Make certain valve seats in bottom of bore.

18. Install 2-3 modulator valve, hole end first, into 2-3 modulator bushing and install both parts in lower left bore.

19. Install 2-3 shift valve spring into hole in 2-3 modulator valve, and compressing spring, secure with retaining pin from cored side of control valve.

20. Position front accumulator spring and piston into valve body and install Control Valve Accumulator Piston Installer, J-21885, on piston. Compress spring and piston, aligning spring and piston with bore, Figure 92.

**CAUTION:** Make certain that piston pin is correctly aligned with hole in piston and that oil seal ring does not catch on lip of bore when installing piston.

21. Secure piston and spring with E-ring retainer and remove Installer, J-21885.

22. Install manual valve into top bore.

23. Placing control valve assembly on cored surface, position downshift solenoid gasket and detent solenoid on valve body.

24. Install downshift solenoid attaching screws.

25. Install governor drive pipe into control valve body in bore by rear servo cover.

26. Install two governor screen assemblies with open end up into case.

## INSTALL CONTROL VALVE ASSEMBLY

1. Using two guide pins, install control valve as-

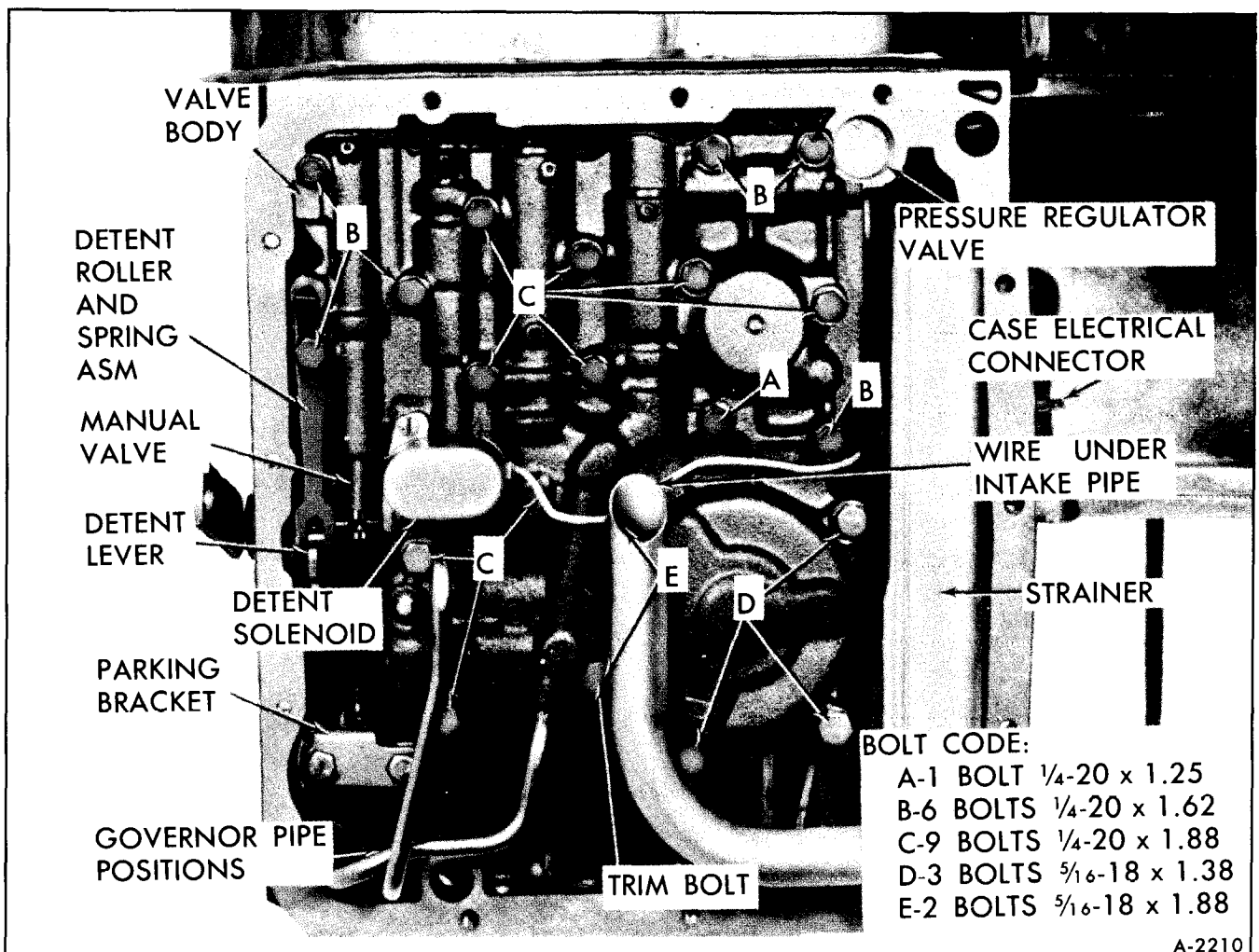

Figure 93—Control Valve Screws

sembly and governor pipe on transmission. Make certain gaskets and spacer do not become mispositioned.

**NOTE:** Check manual valve to make sure it is indexed properly with pin on detent lever and governor pipe to make certain it is properly seated in case hole.

2. Remove guide pins and install control valve assembly attaching screws, eliminating detent roller and spring assembly attaching screw. Torque bolts to 8 foot-pounds, Figure 93.

3. Install detent roller and spring assembly and attaching screw. Tighten screw to 8 foot-pounds.

4. Install detent terminal and lead wire to case connector.

5. Install governor feed pipe in transmission case and control valve body.

**NOTE:** Make certain that governor feed pipe is seated in bores in case and valve body.

## PRESSURE REGULATOR VALVE, INTAKE PIPE AND FILTER ASSEMBLY, BOTTOM PAN, MODULATOR VALVE AND MODULATOR

### INSTALL PRESSURE REGULATOR VALVE

1. Install spring retainer on pressure regulator spring. Also install spacers if previously removed, Figure 94.

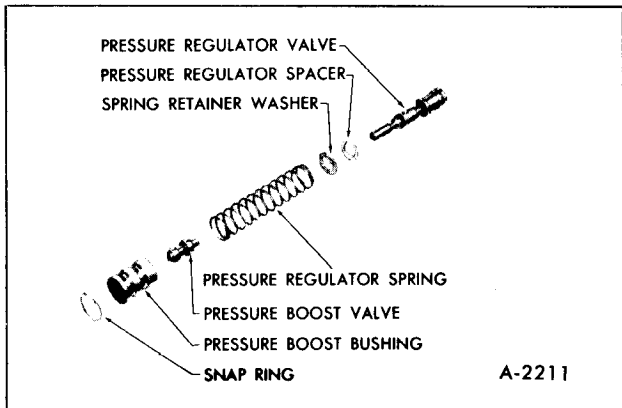

Figure 94—Pressure Regulator Valve

2. Install pressure regulator valve on spring, stem end first.

3. Install boost valve into bushing, stem end out, and stack parts so that pressure regulator spring is against valve bushing.

4. Install complete assembly, pressure regulator valve first, into pressure regulator valve bore, being careful not to drop parts during installation.

5. Using a screwdriver or steel rod, compress regulator boost valve bushing against pressure regulator spring until it is beyond snap ring groove, and install snap ring using Snap Ring Pliers, J-5403 (#21), Figure 35.

**NOTE:** To facilitate installation of snap ring, encircle it around screwdriver or steel rod, compress tangs with snap ring pliers, and slide snap ring into ring groove in valve bore.

### INSTALL INTAKE PIPE AND FILTER ASSEMBLY AND BOTTOM PAN

1. Install new intake pipe O-ring into pipe bore in transmission case and install intake pipe and filter assembly.

2. Install new bottom pan gasket on transmission case and install bottom pan.

3. Install 13 bottom pan attaching screws. Tighten screws to 12 foot-pounds.

### INSPECT VACUUM MODULATOR AND VALVE

1. Inspect vacuum modulator for any signs of bending or distortion.

2. Inspect O-ring seat for damage.

3. Inspect modulator valve for nicks or damage.

4. Check freeness of valve operation in case bore.

5. Check modulator for damaged bellows. Modulator plunger is under approximately 16 pounds pressure. If bellows is damaged, plunger will have very little pressure.

## INSTALL MODULATOR VALVE AND VACUUM MODULATOR

1. Install modulator valve into case with stem end out.
2. Install new O-ring on vacuum modulator.
3. Install vacuum modulator into case with vacuum hose pipe facing case connector.
4. Install modulator retainer with curved side of tangs inboard and install attaching screw. Tighten screw to 18 foot-pounds.

## GOVERNOR ASSEMBLY

**NOTE:** All components of the governor assembly, with the exception of the driven gear, are a select fit and each assembly is factory calibrated. The governor, including the driven gear, is serviced as a complete assembly. However, the driven gear can also be serviced separately.

## GOVERNOR INSPECTION

1. Wash in cleaning solvent, and blow out all passages.
2. Inspect governor sleeve for nicks, burrs, scoring or galling.
3. Check governor sleeve for free operation in bore of transmission case.
4. Check governor valve for free operation in bore of governor sleeve.
5. Inspect governor driven gear for nicks, burrs, or damage.
6. Check governor driven gear for looseness in governor sleeve.
7. Inspect speedometer drive gear for nicks, burrs, or damage.
8. Check speedometer drive gear for looseness on governor sleeve.
9. Inspect governor springs for distortion or damage.
10. Check governor weights for free operation in their retainers.

11. Check valve opening at entry and exhaust (.020" minimum).

## GOVERNOR DRIVEN GEAR REPLACEMENT

To facilitate governor repair in the field, governor driven gear and replacement pins are available for service use. The service package contains a nylon driven gear, two governor weight retaining pins and one governor gear retainer split pin. Replacement of gear must be performed with care in the following manner:

1. Place governor sleeve on a block of wood and drive retaining pin out, using a small punch or 1/8" drill rod.
2. Remove governor driven gear as follows:
  - a. Insert governor driven gear in a vice.
  - b. Firmly grip governor sleeve with hands and twisting and pulling at the same time, pull governor sleeve away from the governor driven gear.
  - c. Discard governor driven gear.
3. Remove generator valve and wash all parts in cleaning solvent and blow off parts.
4. Install governor valve, end with holes last, into governor sleeve.
5. Support governor on 7/64" plates, installed in exhaust slots of sleeve, position new gear in sleeve and with a 7/16" socket, press gear into sleeve until seated. See Figure 95.

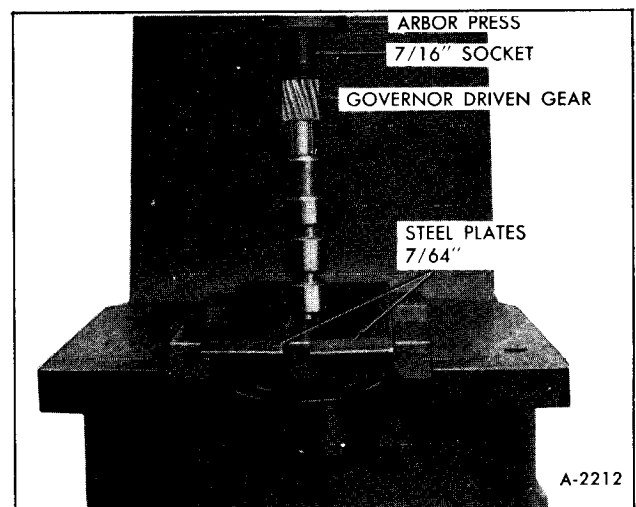

Figure 95—Installing Governor Gear

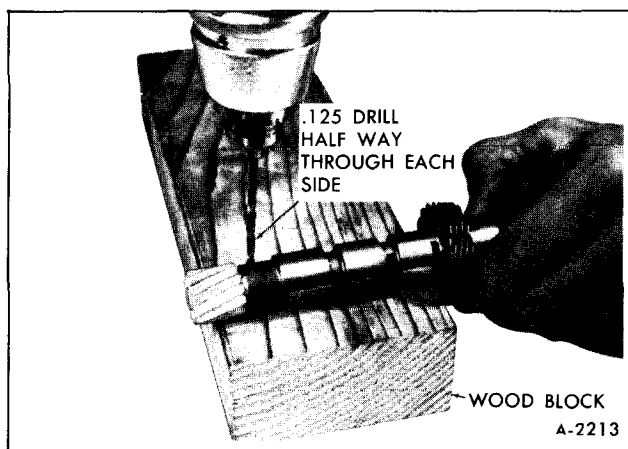

Figure 96—Drilling Governor Gear Shaft

6. Place governor sleeve on a block of wood and with a 1/8" drill, drill half way through each side of gear; drill through existing hole. See Figure 96.

7. Install split retaining pin, making sure each end is slightly below top of hole.

**CAUTION:** *Extreme care must be taken to prevent damaging the parts.*

8. Stake both ends of pin hole, two places.

9. Thoroughly wash governor assembly in cleaning solvent and blow out all passages.

## INSTALL GOVERNOR

1. Rotate transmission in Holding Fixture Base so that governor bore is up.

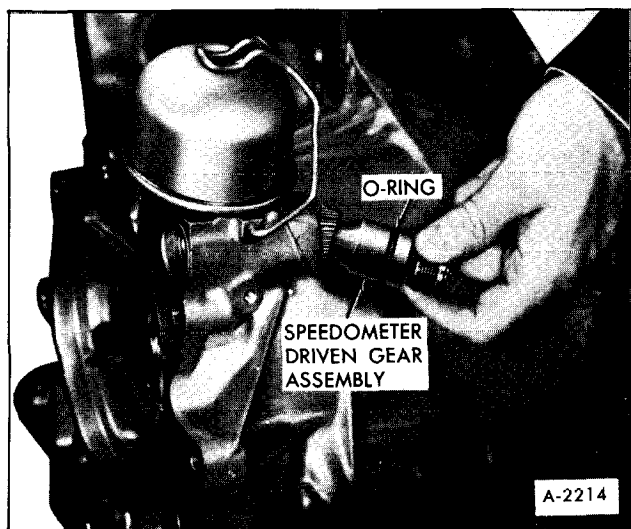

Figure 97—Installing Speedometer Driven Gear

2. Install new square cut O-ring seal on governor assembly and install assembly into transmission case.

3. Position retaining clip on top of governor assembly.

## INSPECT SPEEDOMETER DRIVEN GEAR ASSEMBLY

1. Inspect gear for damaged teeth or shaft.

2. Inspect sleeve for scores, damaged threads or cracks.

## INSTALL SPEEDOMETER DRIVEN GEAR

1. Install new O-ring seal on speedometer driven gear assembly.

2. Lubricate housing lip with a thin coat of Dex-ron transmission fluid.

3. Install speedometer housing and seal assembly and white nylon driven gear into transmission case, Figure 97.

4. Position retaining clip to transmission and driven gear assembly and secure with one attaching bolt, tightening bolt to 6 ft. lbs.

## CONVERTER

### INSPECT TORQUE CONVERTER

1. Check converter for leaks as follows:

a. Insert valve, part of Converter Leak Test Fixture, J-21369, in neck of converter and back-off large hex nut.

b. Install leak test fixture band crosswire on converter so that slotted plate fits around valve and under nut. Tighten nut to expand O-ring and secure a good seal.

c. Apply compressed air with a service air hose until approximately 80 to 100 psi. air pressure is obtained.

d. Immerse assembly in water, noting any sign of bubbles that would indicate a leak.

**WARNING: ALWAYS RELEASE AIR PRESSURE BEFORE REMOVING VALVE, AS A DEFINITE HAZARD EXISTS SHOULD VALVE BLOW OUT DURING REMOVAL.**

e. Thoroughly dry converter.

2. Check converter hub surfaces for signs of scoring or wear.

## **INSTALL TORQUE CONVERTER**

1. Position transmission jack to transmission and install transmission on jack using safety chain.

2. Carefully position converter on turbine shaft, making certain converter is properly aligned. Long screws or eyebolts can be threaded into the weld nuts on the converter and used as handles.

3. Rotate converter until the shafts are piloted and the converter lugs are indexed in the pump gear.

4. If difficulty is experienced in alignment, tap on outer diameter of converter with plastic-headed hammer, while turning converter.

5. Install Converter Holding Clamp, J-21366, on transmission case.

6. Remove two (2) 8" bolts from case to engine mounting face.

## **INSTALLING FINAL DRIVE (FIGURE 29)**

1. Install new gasket, on final drive, after first soaking with transmission fluid.

2. Align final drive to transmission and secure with bolts "B, C, E, F, G" and nut "H", torque to 25 ft.-lbs.

3. Install new O-ring on filler tube assembly and assembly to final drive. Torque bolt "A" to 25 ft.-lbs.

**NOTE:** Install transmission and final drive in vehicle as described earlier in this section.

## TRANSMISSION SPECIFICATIONS

### TORQUE CHART

Material Number	Application	Thread Size	Foot Pounds
280M	Transmission to Engine Bolts.....	3/8-16	35
300M	Torque Converter to Flywheel .....	3/8-16	30
1010	Flywheel Housing Cover .....	5/16-18	5
300M	Final Drive to Transmission .....	3/8-16	25
280M	Solenoid to Case Screw .....	1/4-20	10
Special	Line Pressure Plug.....	1/8 Pipe	13
260M	Vacuum Modulator Retainer.....	5/16-18	18
260M	Valve Body to Case.....	1/4-20	8
300M	Center Support to Case.....	3/8-16	23
286M	Manual Shaft to Inside Lever.....	3/8-24	18
280M	Pump Body to Cover Plate .....	5/16-18	20
280M	Parking Brake Bracket to Case .....	5/16-18	18
1010-1020	Oil Pan to Case.....	5/16-18	12
280M	Sprocket Housing .....	1/4-20	8
260M	Support Housing to Cover Plate .....	5/16-18	20
260M	Speedometer Driven Gear Retainer .....	5/16-18	18

### SPECIAL TOOLS

J 4646	Snap Ring Pliers
J 4670-01	Forward Clutch Spring Compressor (Use with J-6129 & J-21664).....
J 5907	Pressure Gauge Set (0-300 psi-9' hose) .....
J 6116-01	Clutch Unit Holding Fixture .....
J 6129	Direct Clutch Spring Compressor .....
J 6133-01	Rear Oil Pump Bearing & Speedo Gear Installer .....
J 21359	Front Pump Oil Seal Installer .....
J 21362	Forward & Direct Clutch Inner Seal Protector.....
J 21363	Second Clutch Inner Seal Protector.....
J 21369	Converter Leak Test Fixture .....
J 21370-6	Band to Apply Pin-Body Arm Assembly (Use with J-21370-7 & 8).....
J 21370-7	Band to Apply Pin Gauge (Used with J-21370-6 & 8)
J 21370-8	Band to Apply Pin Selector Plate (Used with J-21370-6 & 7) .....
J 21409	Forward & Direct Clutch Outer Seal Protector .....
J 21661	Speedometer Drive Gear Remover Bolts .....
J 21664	Clutch Compressor Adapter .....
J 21795-02	Gear Unit Holding Tool .....
J 22241	Forward Clutch End Play Checking Tool.....
J 22269-01	Control Valve Direct Clutch Accumulator Piston Compressor .....



# SECTION 8 FUEL TANK AND EXHAUST

Contents of this section are listed below:

SUBJECT	PAGE NO.
Evaporation Control System (E.C.S.).....	8-1
Description.....	8-1
Trouble Diagnosis .....	8-2
Servicing E.C.S. ....	8-3
Canister(s) .....	8-3
Canister Filter .....	8-3
Hoses and Lines.....	8-3
Liquid/Vapor Separator .....	8-3
Fuel Tanks and Lines .....	8-4
Description.....	8-4
Draining Fuel Tanks .....	8-4
Fuel Tank Replacement .....	8-4
Fuel Tank Gauge Replacement.....	8-6
Cleaning Fuel Systems.....	8-6
Fuel Tank Purging Procedure.....	8-7
Fuel Tank Leak Test Procedure .....	8-7
Exhaust System .....	8-7
Description.....	8-7
Maintenance.....	8-8

## EVAPORATION CONTROL SYSTEM (E.C.S)

### DESCRIPTION

In order to limit gasoline vapor discharge into the atmosphere, the following features are incorporated in the fuel system. The E.C.S. system (figure 1) is designed to trap fuel vapors which normally escape from the fuel tank. Vapor arrest is accomplished through the use of a charcoal canister(s) which absorbs the fuel vapors and stores them until they can be removed to be burned in the engine. Removal of vapors from the canister(s) to the engine is accomplished by a calibrated purge orifice in the carburetor. In addition to the carburetor modifications and the canister(s), the fuel tank requires a special

pressure-vacuum gas cap and extra vents to liquid/vapor separator. The liquid/vapor separator prevents liquid gasoline from entering the vapor system to the canister(s). Thus, as vapors are generated in the fuel tank, they flow through the liquid/vapor separator and to the canister(s) where they are stored. From the canister(s) the vapors are routed to the carburetor where they will be burned during normal combustion.

On vehicles sold in California an additional canister is used along with two shields between the fuel tanks and exhaust pipe.

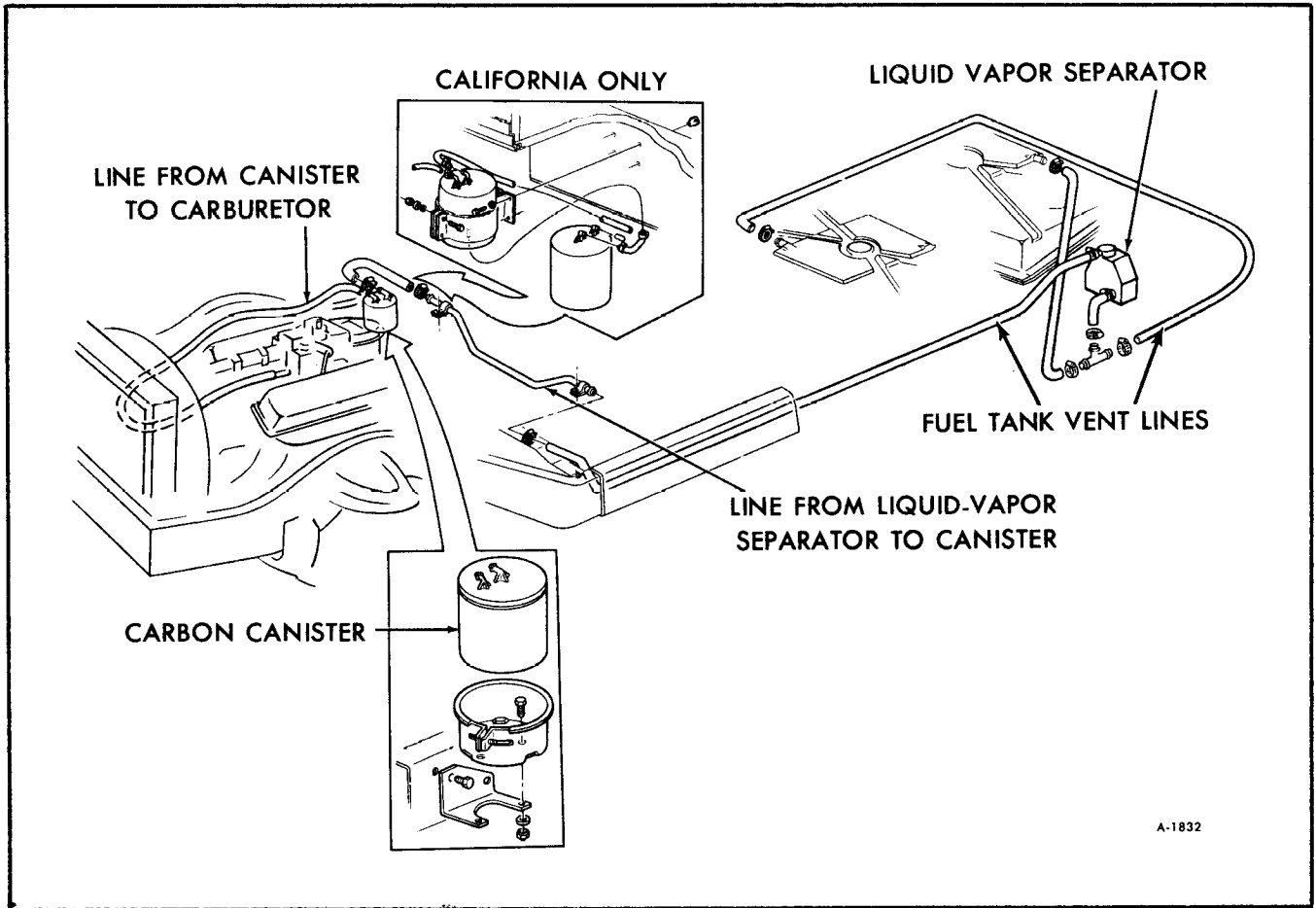

Figure 1—Evaporation Control System

## TROUBLE DIAGNOSIS

Condition	Possible Cause	Correction
Fuel odor or loss of fuel rough idle.	Leak in fuel line(s) or hose(s). Purge hose improperly routed. Disconnected purge hose. Plugged canister filter. High volatility fuel.	Replace line or hose.  Route hose correctly.  Connect hose to proper fitting. Replace filter. Change brand of fuel.
Collapsed tank or pressure in tank.	Plugged or pinched vent line(s). Defective canister. Faulty valve in special tank filler cap.	Remove obstruction or replace line.  Replace canister. Install specified replacement cap.



## SERVICING E.C.S.

### CANISTER(S)

The plastic canister is filled with charcoal which absorbs and stores fuel vapors. When fuel is drawn from the tank during engine operation, a fuel cap tank relief valve opens allowing air to be drawn into the tank. When the engine is running, air is drawn in through the bottom of the canister. This air picks up vapors which are being held in the charcoal and carries them through the carburetor into the engine where they are burned.

### REMOVAL

1. Vehicle may be raised if desired.
2. If vehicle is equipped with one canister loosen clamp screw and lift canister up and out.
3. If vehicle is equipped with two canisters remove the lower canister clamp from bracket and slide canister and clamp out. See Figure 1.
4. Disconnect hoses from canister(s).
5. If vehicle is equipped a second canister loosen clamp and lower canister enough to disconnect hoses so it may be removed.

### INSTALLATION

1. If the vehicle is equipped with two canisters connect hoses to the upper canister and install. Tighten clamp.
2. Connect hoses to remaining canister and install. Tighten clamp as required.

### CANISTER FILTER

#### REMOVAL

1. Remove canister. Refer to "Canister-Removal" earlier in this section.
2. Filter is located in the bottom of the canister. If vehicle is equipped with two canisters the filter is in the lower canister.
3. Remove filter.

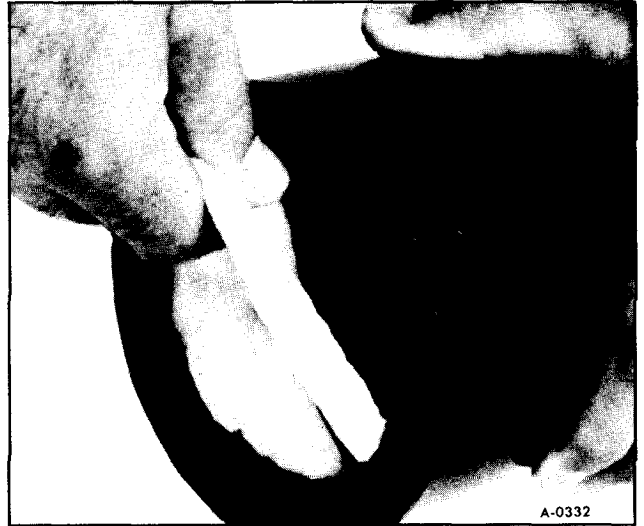

Figure 2—Replacing Canister Filter

### INSTALLATION

1. Install filter. See Figure 2.
2. Install canister. Refer to "Canister-Installation" earlier in this section.

### HOSES AND LINES

Conventional steel tubing, vapor resistant hose and hose clamps are used to connect the various components of the system. It is extremely important that all pipes and hoses are not kinked, are properly connected, and that all connections are tight. This is necessary to assure a vent through the system for the fuel tank to prevent restriction of vapors to the canister. Thorough visual inspection is and will remain one of the most important checks of the system.

**IMPORTANT:** Use only hose marked "EVAP" or "GM 6107M" if necessary to replace an E.C.S. hose. Gasoline vapors will deteriorate other types of hoses.

### LIQUID/VAPOR SEPARATOR

#### DESCRIPTION

An external liquid-vapor separator is mounted to left rear wheel opening liner. It's purpose is to stop fuel that has drained out of tanks when the vehicle is parked off level. Once a level position is assumed the fuel in the separator will drain back into the tank.

Any vapors collected in the separator are routed to the canister by a hose. The separator can not be serviced. If damaged it must be replaced.

### REMOVAL

1. Clean threads of dirt and remove attaching nuts.
2. Move separator off studs. Mark hoses with

some identification to assure proper matching of hoses and outlets.

3. Disconnect hoses and remove separator.

### INSTALLATION

1. Connect hoses to proper ports.
2. Install separator and tighten nuts.

## FUEL TANKS AND LINES

### DESCRIPTION

The fuel tanks in the models 230 and 260 Motor Homes are dual 25 gallon capacity tanks for a total of 50 gallons. The tanks are located between the frame rails forward of the bogey crossmember.

The filler neck and tubes are constructed of steel tubing with rubber connecting hoses secured by worm-type hose clamps as shown in Figure 3.

The fuel pickup pipe is built integrally with the tank gauge sending unit, located at the top of the tank. A large area, fine mesh screen is located on the bottom of the fuel pickup pipe. This screen is designed to prevent the entrance of dirt or water into the fuel system, and operates with a self-cleaning action.

The tanks consist of an upper and lower half each with a wide flange. The two tank sections are seam welded at the flange to assure leak proof construction. Exceptional stiffness is obtained by the combination of the welded flanges and depressed ribs in both upper and lower tank sections.

### DRAINING FUEL TANKS

**WARNING: BEFORE ATTEMPTING TO DRAIN FUEL TANK, ALWAYS; REMOVE BATTERY NEGATIVE CABLES, PLACE "NO SMOKING" SIGNS AND A CO2 FIRE EXTINGUISHER NEAR WORK AREA, WEAR SAFETY GLASSES, AND SIPHON OR PUMP FUEL FROM TANK INTO AN EXPLOSIVE PROOF CONTAINER.**

The fuel tanks incorporate a drain plug in the left front corner of the tanks. (See figure 4)

To drain the tank remove the drain plug in the tank with the correct size Allen wrench.

Always drain gasoline from complete fuel system including carburetor, fuel pump, all fuel lines and fuel tank if the vehicle is to be stored for any appreciable length of time. This precaution will prevent accumulation of gum formation and resultant poor engine performance.

### FUEL TANK REPLACEMENT

**WARNING: BEFORE ATTEMPTING FUEL TANK REMOVAL, ALWAYS; REMOVE BATTERY NEGATIVE CABLES, PLACE "NO SMOKING" SIGNS AND A CO2 FIRE EXTINGUISHER NEAR WORK AREA, WEAR SAFETY GLASSES, AND SIPHON OR PUMP FUEL FROM TANK INTO AN EXPLOSIVE PROOF CONTAINER.**

1. Drain tanks as previously described.
2. Disconnect fuel filler tubes by loosening worm clamps and slide rubber connectors off ends.
3. Remove 3 bolts from angle at front of tank as shown in Figure 5. If both tanks are to be removed, the forward tank should be completely removed.
4. Slowly lower tanks to allow removal of vent lines and fuel feed lines, label or mark lines to allow reconnection of lines with the same outlet.
5. Using Tool J-24187 as illustrated in Figure 6. Remove fuel tank gauge unit.
6. Reverse steps 1-5.

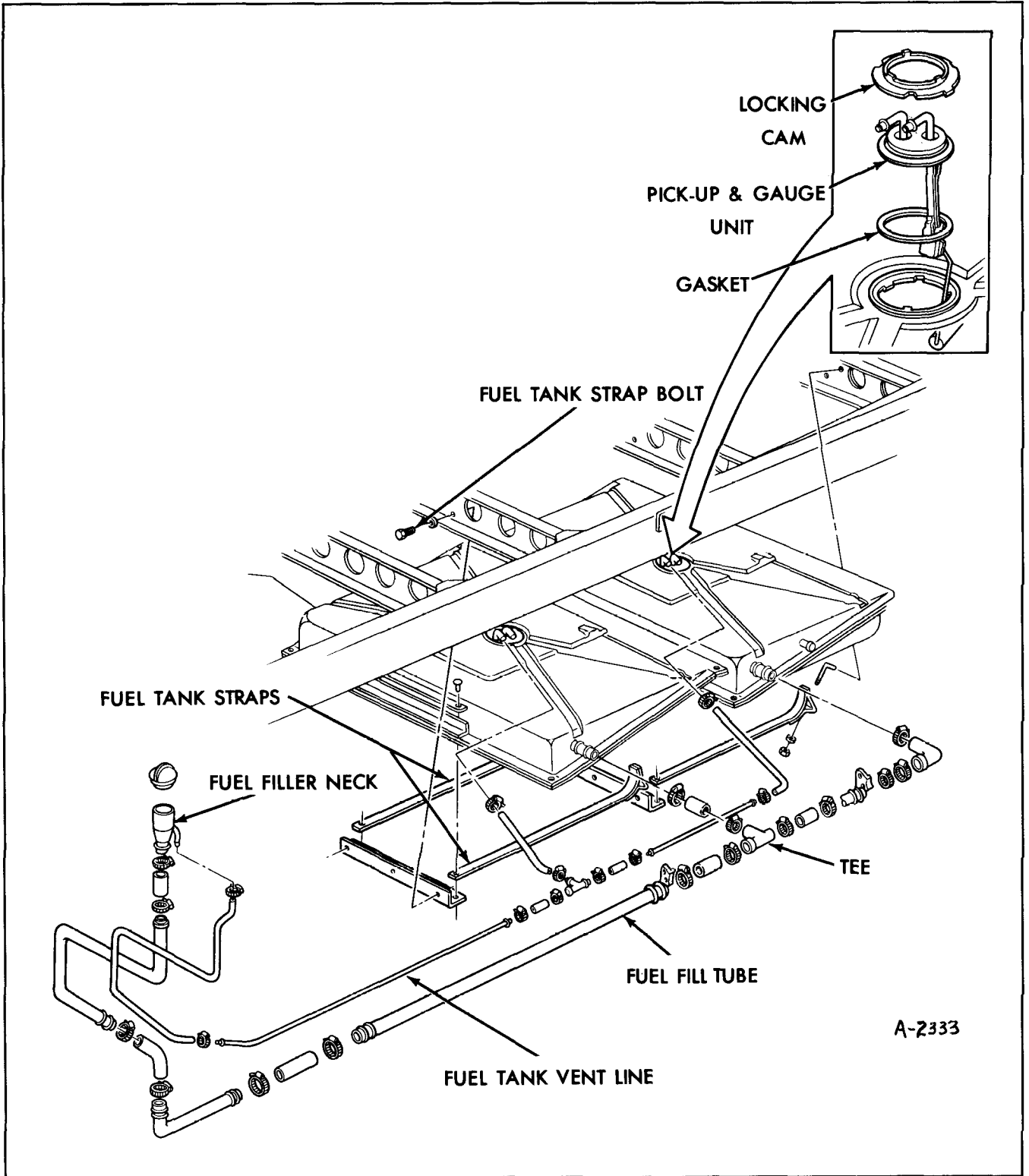

Figure 3—Fuel Tanks and Lines

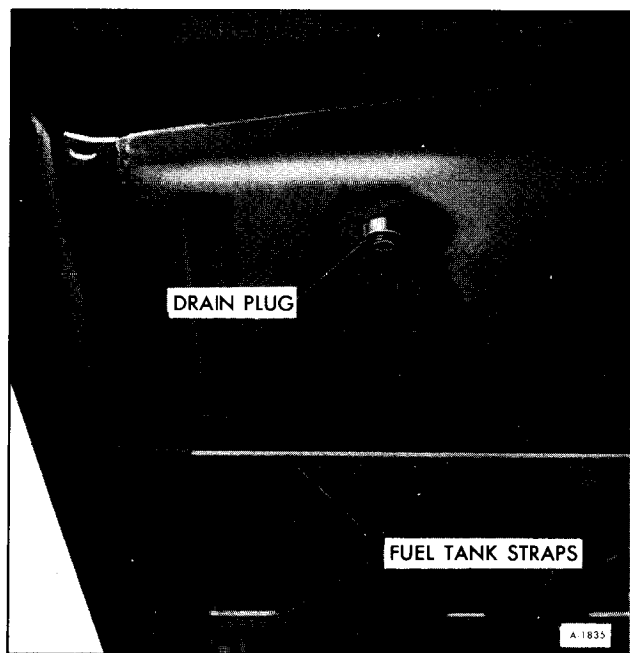

Figure 4—Fuel Tank Drain Plug

## FUEL TANK GAUGE REPLACEMENT

1. Follow steps outlined in Fuel Tank Removal.
2. Remove fuel gauge retaining cam, using Tool J-24187 (figure 6).
3. Test gauge unit if required according to the diagnosis check list for fuel tank gauge in Section 12.
4. Reverse steps 1–3, and check operation of gauge.

## CLEANING FUEL SYSTEMS

If trouble is due to contaminated fuel or foreign material that has been put into the tank, it can usu-

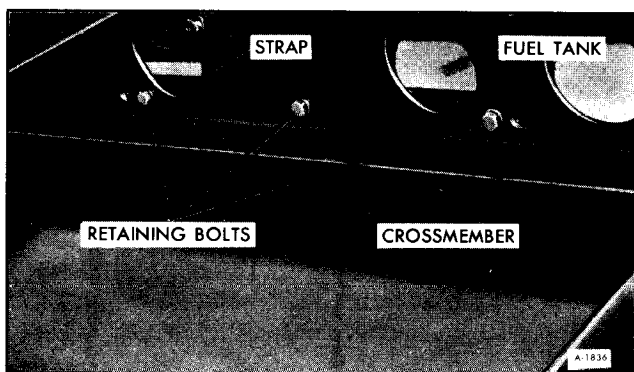

Figure 5—Removing Fuel Tank Strap Bolts

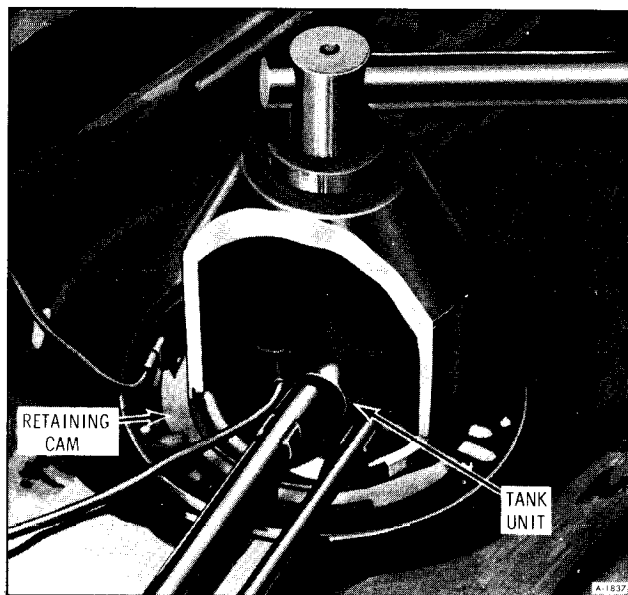

Figure 6—Removing Fuel Tank Gauge Unit

ally be cleaned. If tank is rusted internally, it should be replaced.

1. Disconnect battery ground cables and ignition coil primary wire (+ wire on ignition coil).
2. Drain fuel tank. (See DRAINING FUEL TANK).
3. Remove fuel tank. (See FUEL TANKS – REPLACEMENT).
4. Remove fuel inlet filter at carburetor and inspect for contamination. If filter is plugged, replace. (Leave fuel line disconnected.)
5. Locate tank away from heat, flame or other source of ignition. Remove fuel gauge tank unit and inspect condition of filter. If filter is contaminated, a new filter should be installed upon reassembly.
6. Complete draining of tank by rocking it and allowing fuel to run out of tank unit hole.
7. Purge fuel tank with steam or running hot water for at least five minutes. Pour water out of tank unit hole. (Rock tank to assure complete removal of water.)

**IMPORTANT:** This procedure will not remove fuel vapor. Do not attempt any repair on tank or filler neck where heat or flame is required.

8. Disconnect inlet fuel line at pump and use air pressure to clean fuel line and fuel return line (if equipped). Apply air pressure in the direction fuel normally flows through line.

9. Use low air pressure to clean pipes on tank unit.

10. Install new filter on fuel tank unit if required. Install fuel tank unit with new gasket into tank and install tank. Connect tank unit wires and all fuel lines except pump to carburetor line. (See REMOVAL OF TANK for proper procedure).

11. Connect a hose to fuel line at carburetor, insert other end of hose into a one gallon fuel can.

12. Connect battery cable. **MAKE SURE IGNITION COIL PRIMARY WIRE (+TERMINAL) IS DISCONNECTED.**

13. Put six gallons of clean fuel in tank and operate starter to pump two quarts of fuel into fuel can. This will purge fuel pump.

14. Remove hose and connect fuel line to carburetor.

15. Connect coil primary wire.

16. Connect battery ground cables.

## FUEL TANK PURGING PROCEDURE

1. Remove fuel gauge unit and drain all remaining fuel from tank.

2. Visually inspect interior cavity of tank; if any fuel is evident, drain again.

3. Move tank to flushing area (wash rack).

4. Pour gasoline emulsifying agent and water solution into the tank and agitate mixture for 2 to 3 minutes, wetting all interior surfaces.

**NOTE:** For correct gasoline emulsifying agent – water mixture, refer to the emulsifying agent

manufacturer's specifications. Use an available emulsifying agent such as "Product -Sol No. 913" or equivalent.

5. Fill tank (with water) to capacity and agitate again.

6. Empty contents.

7. When empty, refill to overflowing with water to completely flush out remaining mixture and then empty tank.

8. If any vapor is present, repeat Steps 4 thru 8. Repeat as necessary until there is no evidence of fuel vapor.

9. Dry tank with compressed air and perform required service work.

## FUEL TANK LEAK TEST PROCEDURE

1. Plug all outlets as follows:

a. Use a known good filler cap for filler neck.

b. Install tank unit and plug fuel line.

c. Plug two (2) of the three (3) tank vent tubes using a single short piece of fuel line hose.

d. Install another short piece of fuel line hose on third vent tube.

2. Apply air pressure to tank through open vent tube. Use extreme caution to prevent rupturing the tank. When air can be heard escaping from the filler neck cap (approximately 1 to 1-1/2 lbs. of pressure) pinch the fuel line hose to retain pressure.

3. Test repaired area for leaks with soap solution or by submersion. If leak is noted, make repair and retest.

## EXHAUST SYSTEM

### DESCRIPTION

The exhaust system on the models 230 and 260 are essentially identical except for a longer length tail

pipe on the 260 model. The exhaust manifolds empty into a muffler for each bank of cylinders which are Y'ed as shown in Figure 7. The tail pipe continues to rear of the vehicle. All exhaust system connections are of the split joint coupled design, secured with U-Bolt clamps.

On all exhaust and tail pipe clamp installations locate centerline of clamp to end of slot in pipe as shown.

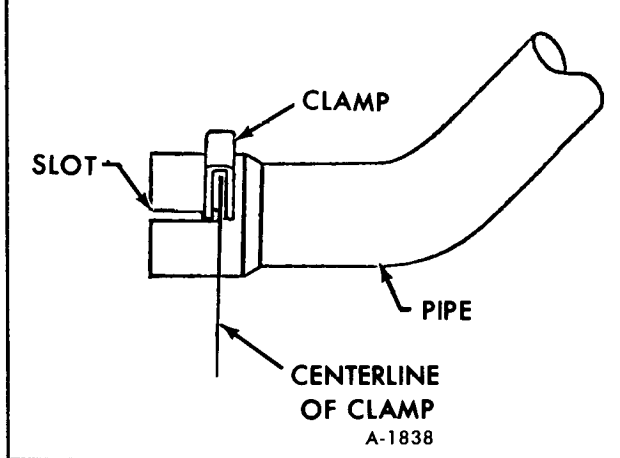

Figure 7—Exhaust System & Clamps

## MAINTENANCE

### EXHAUST RESTRICTION AND LEAKS

Exhaust system should be inspected periodically for restrictions and leaks. Restrictions such as kinked or crimped pipes result in excessive back pressure which can lead to increased fuel consumption, power loss, and possible damage to engine combustion chamber components. Exhaust leaks are commonly the result of loose clamp assemblies, defective exhaust pipe to manifold packing, or corroded pipes. In addition to objectionable noise, a leaking exhaust system could allow toxic gases to enter vehicle.

Damaged or corroded exhaust system components should be replaced without delay. If it is absolutely necessary to operate vehicle when an exhaust leak exists, use extreme caution and keep vehicle well ventilated.

### EXHAUST SYSTEM ALIGNMENT

During installation of a new exhaust pipe, muffler or tail pipe, care should be taken to properly position components in relation to each other.

On all joints except exhaust manifold, apply sealer (GM 9985020) or equivalent, to prevent possible leaks.

Incorrectly assembled parts of exhaust system are frequently the cause of annoying noises and rattles due to improper clearances. Exhaust components must have 3/4" clearance from floor to avoid possible overheating. Therefore, leave all clamp assemblies and muffler strap bolts loose temporarily until the entire system has been inspected to determine if there is adequate clearance between exhaust components and frame members. The weight of the exhaust system should be properly distributed on all supporting brackets and hangers. If the load is not properly balanced, reposition pipes at connecting joints to relieve any concentrated loads. After adjusting hangers, aligning pipes, and repositioning muffler, check entire system for adequate clearance and then tighten all clamps, working from front to rear. (See figure 8) Start engine and inspect all connections for leakage.

**NOTE:** When installing exhaust pipe to manifold, always use new packing.

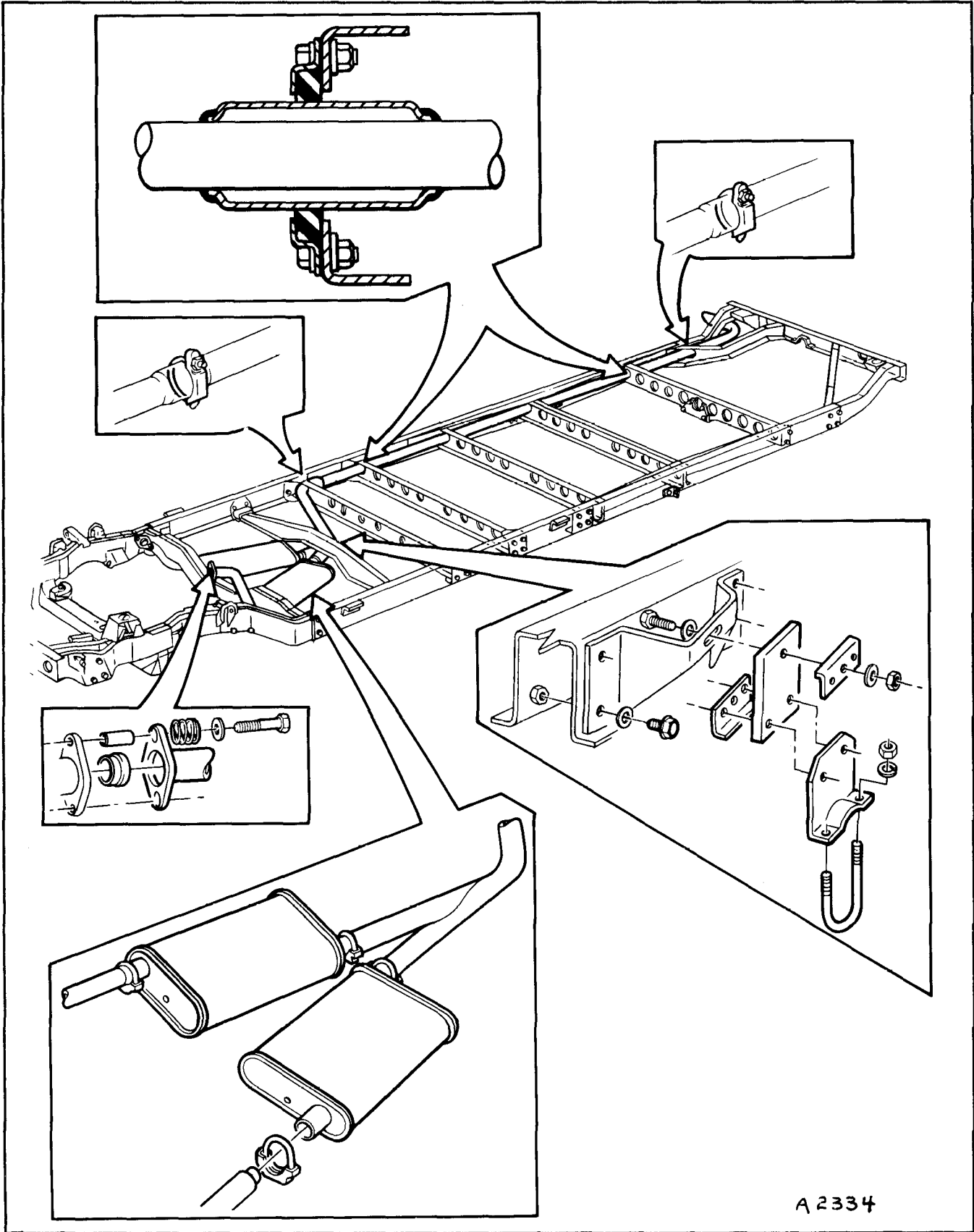

A2334

Figure 8-Exhaust Pipe Clamp Installation

# SECTION 9 STEERING

Contents of this section are listed below.

SUBJECT	PAGE NO.
Steering Linkage .....	9- 1
Power Steering Pump .....	9- 4
Steering Gear .....	9-19
Steering Column .....	9-35
Torque Specifications.....	9-63
Special Tools .....	9-64

**CAUTION:** *All steering linkage fasteners are important attaching parts in that they could affect the performance of vital components and systems, and/or could result in major repair expense. They must be replaced with one of the same part number or with an equivalent part if replacement becomes necessary. Do not use a replacement part of lesser quality or substitute design. Torque values must be used as specified during reassembly to assure proper retention of these parts.*

## STEERING LINKAGE

### GENERAL INFORMATION

A parallelogram type steering linkage connects both front wheels to the steering gear through the pitman arm (See figure 1). The right and left tie rods are attached to steering arms at the wheels and to a forged intermediate rod by ball studs.

The left end of the intermediate rod is supported by the relay lever which is driven by the drag link

connected to the pitman arm on the steering gear. The right end of the intermediate rod is supported by an idler arm which pivots on a support attached to the frame. The rear portion of the relay lever and the idler arm are always parallel to each other and move through symmetrical arcs.

The steering linkage is equipped with a linkage shock absorber connected from the intermediate rod to the frame. This is designed to absorb much of the shock to the steering system.

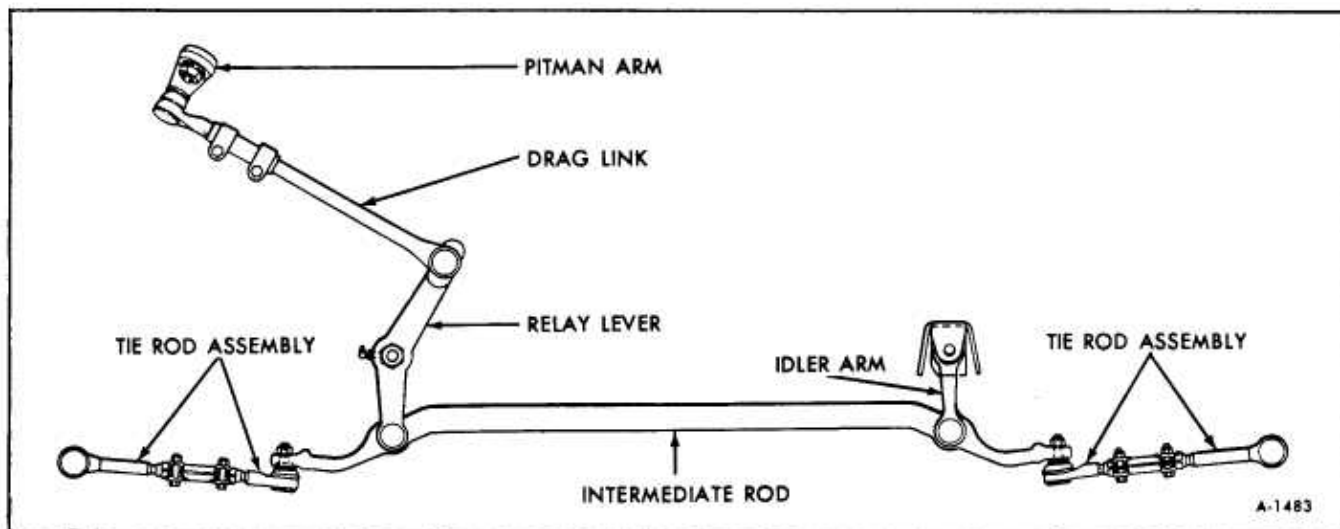

Figure 1-Steering Linkage



## STEERING LINKAGE TROUBLE DIAGNOSIS

Condition	Possible Cause	Correction
<p><b>A. Excessive Play or Looseness in Steering System</b></p>	<ol style="list-style-type: none"> <li>1. Front wheel bearings loosely adjusted.</li> <li>2. Worn couplings or steering shaft U-joints.</li> <li>3. Worn upper ball joints.</li> <li>4. Steering wheel loose on shaft, loose pitman arm, tie rods, steering arms or steering linkage ball studs.</li> <li>5. Steering gear worm bearings loosely adjusted.</li> <li>6. Excessive pitman shaft to ball nut lash in steering gear.</li> <li>7. Worn intermediate rod or tie rod sockets.</li> </ol>	<ol style="list-style-type: none"> <li>1. Adjust bearings or replace with new parts as necessary.</li> <li>2. Replace.</li> <li>3. Replace.</li> <li>4. Tighten to specified torque.</li> <li>5. Adjust preload to specification.</li> <li>6. Adjust preload to specification.</li> <li>7. Replace worn part.</li> </ol>
<p><b>B. Excessive looseness in tie rod or intermediate rod pivots, or excessive vertical lash in idler support.</b></p>	<ol style="list-style-type: none"> <li>1. Seal damage and leakage resulting in loss of lubricant, corrosion and excessive wear.</li> </ol>	<ol style="list-style-type: none"> <li>1. Replace damaged parts as necessary.</li> </ol>
<p><b>C. Hard Steering--Excessive Effort Required at Steering Wheel.</b></p>	<ol style="list-style-type: none"> <li>1. Low or uneven tire pressure.</li> <li>2. Steering linkage or ball joints need lubrication.</li> <li>3. Tight or frozen intermediate rod, tie rod or idler socket.</li> <li>4. Steering gear to column misalignment.</li> <li>5. Steering gear adjusted too tightly.</li> <li>6. Front wheel alignment incorrect.</li> </ol>	<ol style="list-style-type: none"> <li>1. Inflate to specified pressures.</li> <li>2. Lube with specified lubricant.</li> <li>3. Lube or replace as necessary.</li> <li>4. Align column.</li> <li>5. Adjust preload to specification.</li> <li>6. Check alignment and correct as necessary.</li> </ol>
<p><b>D. Poor Returnability.</b></p>	<ol style="list-style-type: none"> <li>1. Steering linkage or ball joints need lubrication.</li> <li>2. Steering gear adjusted too tightly.</li> <li>3. Steering gear to column misalignment.</li> <li>4. Front wheel alignment incorrect.</li> </ol>	<ol style="list-style-type: none"> <li>1. Lube with specified lubricant.</li> <li>2. Adjust preload to specifications.</li> <li>3. Align column.</li> <li>4. Check alignment and correct as necessary.</li> </ol>

tighten nuts just enough to align slot in castellated nut to hole in ball stud and install cotter pin.

5. Lubricate all steering linkage sockets.
6. Lower vehicle.

## IDLER ARM

### REMOVAL (FIGURE 1)

1. Raise vehicle.
2. Remove cotter pin and castellated nut from idler arm ball stud at intermediate rod.
3. Disconnect idler arm from intermediate rod using a tool such as J-24319 or similar puller.

## POWER STEERING PUMP

### GENERAL INFORMATION

The housing and internal parts of the pump are inside the reservoir so that the pump parts operate submerged in oil. The reservoir is sealed against the pump housing, leaving the housing face and the shaft hub exposed. The reservoir has a filler neck fitted with a cap. A shaft bushing and seal are pressed into the housing from the front. The drive shaft is inserted through this seal and bushing. A large hole in the rear of the housing contains the functional parts; namely ring, rotor, vanes and plates. A smaller hole contains the control valve assembly and spring.

The thrust plate (figure 2) is located on the inner face of the housing by two dowel pins. This plate has four central blind cavities for undervane oil pressure. The two outer blind cavities direct discharge oil through the two cross-over holes in the pump ring (figure 3), through the pressure plate, and into cavity 1 (figure 4). The two outside indentations in the thrust plate are for intake of the oil from the suction part of the pump.

The pump ring (figure 3) is a plate having the mating surfaces ground flat and parallel. The center hole is a two lobed cam in which the rotor and vanes operate. The ring is placed next to the thrust plate, and located with the same dowel pins.

The pressure plate is fitted against the ring and located with the same two dowel pins. This plate has six through ports. The four central through ports connect from cavity 1 (figure 4) to supply undervane

4. Remove bolt and nut securing idler arm to frame.

### INSTALLATION

1. Secure idler arm to frame using bolt and lock nut. Torque nut to 85 to 110 foot pounds.

2. Connect idler arm ball stud to intermediate rod. Install ball stud nut making sure threads are clean, and torque to 40-50 foot-pounds. Then tighten nuts just enough to align slot in castellated nut to hole in ball stud and install cotter pin.

3. Lubricate all steering linkage sockets as described in SECTION 0 of this manual.

4. Lower vehicle.

oil pressure. The two outer ports pass oil under discharge pressure to cavity 1. The two indentations are for oil intake from the suction part of the pump, cavity 7 (figure 4) into the rotor.

The reservoir is for oil storage. It receives and directs the return oil back to the make-up passage of the pump.

The drive shaft is fitted with a pulley and is belt driven from the crankshaft. The rotor is loosely splined to the drive shaft and secured with a retaining ring. It is located centrally within the ring and between the thrust and pressure plates. The ten vanes are mounted in radial slots in the rotor (figure 3).

### OPERATION

The mode of operation of the power steering pump is based upon the demand of the power steering gear. The various major modes of operation are: slow cornering, moderate to high speed straight ahead driving, and cornering against the wheel stop. The pump is designed to recognize these conditions as required by the steering gear valve and compensates for them internally.

As the drive shaft turns the rotor, the vane tips follow the inner cam surface of the pump ring, moving outward and inward twice during each revolution. This results in a complete pumping cycle every 180 degrees of rotation (figure 3). Oil is moved in the

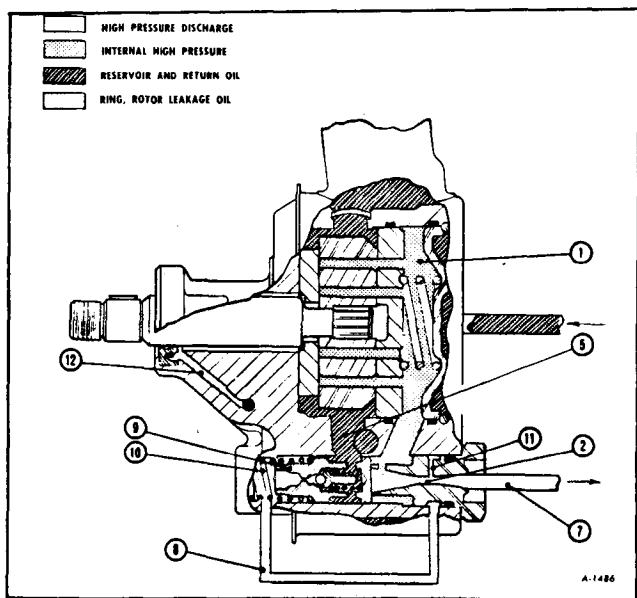

Figure 4-Slow Cornering

(2). This reduces the pressure at the bottom end of the pump control valve (9) because the orifice (11) is connected by passage (8) to (9) resulting in a pressure unbalance on the valve. The flow control valve moves away from the discharge fitting, but due to the force of the flow control spring (10) the valve remains closed to the bypass hole (5). The oil pressure does not build up high enough to cause the pressure relief valve to actuate, because the oil pump through the steering gear is allowed to recirculate through the entire system.

**Moderate To High Speed Operation (Figure 5)**

When operating at moderate to high speed, it is desirable to limit the temperature rise of the oil. This is done by flow controlling. The control valve in the steering gear is an open center rotary valve. When this valve is in the straight ahead position, oil flows from the pump through the open center valve and back to the pump reservoir without traveling through the power cylinder. When this flow exceeds the predetermined system requirements, oil is bypassed within the pump. This is accomplished by the pressure drop which occurs across the flow control orifice (2). The pressure is reduced at the bottom of the flow control valve (9) because the orifice (11) is connected by (8) to the bottom of valve (9).

The pressure unbalance of the valve is sufficient to overcome the force of the spring (10), allowing the valve to open the bypass hole (5), and diverting oil into the intake chamber (6). Supercharging of the intake chamber occurs under these conditions. Oil at high velocity discharging past the valve into the intake chamber picks up make-up oil at hole (4) from

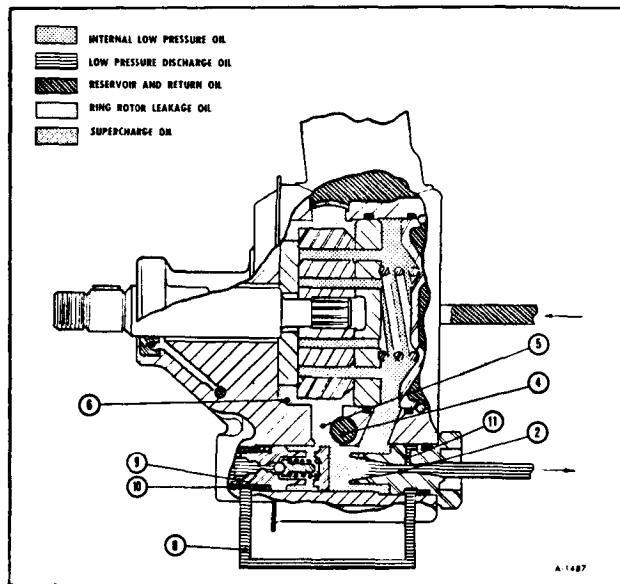

Figure 5-Moderate To High Speed Operation

the reservoir on the jet pump principle. By reduction of velocity, velocity energy is converted into supercharge pressure in cavity (6). During this straight ahead driving condition, the discharge pressure should not exceed 100 psi.

**Cornering Against Wheel Stops (Figure 6)**

When the steering gear control valve is actuated in either direction to the point of cut-off, the flow of oil from the pump is blocked. This condition occurs when the front wheels meet the wheel stop, or when

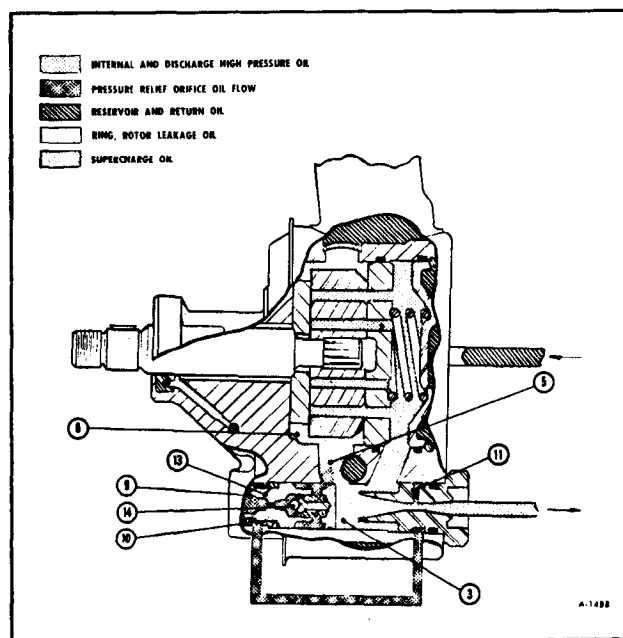

Figure 6-Pressure Relief

## STEERING GEAR AND PUMP DIAGNOSIS CHART

Condition	Possible Cause	Correction
Hissing noise in steering gear.	<p>1. There is some noise in all power steering systems. One of the most common is a hissing sound most evident at standstill parking. There is no relationship between this noise and performance of the steering. "Hiss" may be expected when steering wheel is at end of travel or when slowly turning at standstill.</p>	<p>1. Slight "hiss" is normal and in no way affects steering. Do not replace valve unless "hiss" is extremely objectionable. A replacement valve will also exhibit slight noise and is not always a cure for the objection. Investigate clearance around flexible coupling rivets. Be sure steering shaft and gear are aligned so flexible coupling rotates in a flat plane and is not distorted as shaft rotates. Any metal-to-metal contacts through flexible coupling will transmit valve "hiss" into passenger compartment through the steering column.</p>
Rattle or chuckle noise in steering gear.	<p>1. Gear loose on frame.</p> <p>2. Steering linkage looseness.</p> <p>3. Pressure hose touching other parts of car.</p> <p>4. Loose pitman shaft over center adjustment</p> <p>NOTE: A slight rattle may occur on turns because of increased clearance off the "high point." This is normal and clearance must not be reduced below specified limits to eliminate this slight rattle.</p> <p>5. Loose pitman arm.</p>	<p>1. Check gear-to-frame mounting screws. Tighten screws to 70-foot-pounds.</p> <p>2. Check linkage pivot points for wear. Replace if necessary.</p> <p>3. Adjust hose position. Do not bend tubing by hand.</p> <p>4. Adjust to specifications.</p> <p>5. Tighten pitman arm nut to specifications.</p>
Squawk noise in steering gear when turning or recovering from a turn.	<p>1. Damper "O" ring on valve spool cut.</p>	<p>1. Replace damper "O" ring.</p>
Chirp noise in steering pump.	<p>1. Loose belt.</p>	<p>1. Adjust belt tension to specification.</p>
Belt squeal (Particularly noticeable at full wheel travel and stand still parking).	<p>1. Loose belt.</p>	<p>1. Adjust belt tension to specification.</p>

## STEERING GEAR AND PUMP DIAGNOSIS CHART (Cont'd.)

Condition	Possible Cause	Correction
Growl noise in steering pump.	1. Excessive back pressure in hoses or steering gear caused by restriction.	1. Locate restriction and correct. Replace part if necessary.
Growl noise in steering pump. (Particularly noticeable at stand still parking).	1. Scored pressure plates, thrust plate or rotor.  2. Extreme wear of cam ring.	1. Replace parts and flush system.  2. Replace parts.
Groan noise in steering pump.	1. Low oil level.  2. Air in the oil. Poor pressure hose connection.	1. Fill reservoir to proper level.  2. Tighten connector to specified torque. Bleed system by operating steering from right to left—full turn.
Rattle or knock noise in steering pump.	1. Loose pump pulley nut.	1. Tighten nut to specified torque.
Rattle noise in steering pump.	1. Vanes not installed properly. 2. Vanes sticking in rotor slots.	1. Install properly.  2. Free up by removing burrs, varnish or dirt.
Swish noise in steering pump.	1. Defective flow control valve.	1. Replace part.
Whine noise in steering pump.	1. Pump shaft bearing scored.	1. Replace housing and shaft. Flush system.
Poor return of steering wheel to center.	1. Lack of lubrication in linkage and ball joints. 2. Lower coupling flange rubbing against steering gear adjuster plug. 3. Steering gear to column misalignment. 4. Tires not properly inflated. 5. Improper front wheel alignment.  6. Steering linkage binding.	1. Lube linkage and ball joints.  2. Loosen pinch bolt and assemble properly.  3. Align steering column.  4. Inflate to specified pressure.  5. Check and adjust as necessary. With front wheels still on alignment pads of front end machine, disconnect pitman arm of linkage from pitman shaft of gear. Turn front wheels by hand. If wheels will not turn or turn with considerable effort, determine if linkage or ball joints are binding.  6. Replace pivots.

## STEERING GEAR AND PUMP DIAGNOSIS CHART (Cont'd.)

Condition	Possible Cause	Correction
	<p>7. Ball joints binding. (Turn steering wheel and listen for internal rubbing in column—check causes listed and correct as directed).</p> <p>8. Steering wheel rubbing against directional signal housing.</p> <p>9. Tight or frozen steering shaft bearings.</p> <p>10. Rubber spacer binding.</p> <p>11. Sticky or plugged valve spool.</p> <p>12. Steering gear adjustments over specifications.</p>	<p>7. Replace ball joints.</p> <p>8. Adjust steering jacket.</p> <p>9. Replace bearings.</p> <p>10. Make certain spacer is properly seated. Lubricate inside diameter with silicone.</p> <p>11. Remove and clean or replace valve.</p> <p>12. Check adjustment with gear out of vehicle. Adjust as required.</p>
<p>Vehicle leads to one side or the other. (Keep in mind road condition and wind. Test vehicle on flat road going in both directions).</p>	<p>2. Unbalanced steering gear valve. NOTE: If this is cause, steering effort will be very light in direction of lead and heavy in opposite direction.</p>	<p>2. Replace valve.</p>
<p>Momentary increase in effort when turning wheel fast to right or left.</p>	<p>1. Low oil level in pump.</p> <p>2. Pump belt slipping.</p> <p>3. High internal leakage.</p>	<p>1. Add power steering fluid as required.</p> <p>2. Tighten or replace belt.</p> <p>3. Check pump pressure. (See pump pressure test).</p>
<p>Steering wheel surges or jerks when turning with engine running especially during parking.</p>	<p>1. Low oil level.</p> <p>2. Loose pump belt.</p> <p>3. Steering linkage hitting engine oil pan at full turn.</p> <p>4. Insufficient pump pressure.</p> <p>5. Sticky flow control valve.</p>	<p>1. Fill as required.</p> <p>2. Adjust tension to specification.</p> <p>3. Correct clearance.</p> <p>4. Check pump pressure. (See pump pressure test). Replace relief valve if defective.</p> <p>5. Inspect for varnish or damage, replace if necessary.</p>

## STEERING GEAR AND PUMP DIAGNOSIS CHART (Cont'd.)

Condition	Possible Cause	Correction
Excessive wheel kick-back or loose steering.	<ol style="list-style-type: none"> <li>1. Air in system.</li> <li>2. Steering gear loose on frame.</li> <li>3. Steering gear flexible coupling loose on shaft or rubber disc mounting screws loose.</li> <li>4. Steering linkage joints worn enough to be loose.</li> <li>5. Worn poppet valve (Gear).</li> <li>6. Loose thrust bearing preload adjustment. (Gear).</li> <li>7. Excessive "over-center" lash.</li> </ol>	<ol style="list-style-type: none"> <li>1. Add oil to pump reservoir and bleed by operating steering. Check hose connectors for proper torque and adjust as required.</li> <li>2. Tighten attaching screws to specified torque.</li> <li>3. Tighten flange pinch bolts to 30 foot-pounds, if serrations are not damaged. Tighten upper flange to coupling nuts to specified torque.</li> <li>4. Replace loose pivots.</li> <li>5. Replace poppet valve.</li> <li>6. Adjust to specification with gear out of vehicle.</li> <li>7. Adjust to specification with gear out of vehicle.</li> </ol>
<p>Hard steering or lack of assist.</p> <p>NOTE: If checks 1 through 5 do not reveal cause of hard steering, follow the procedure below to determine fault.</p>	<ol style="list-style-type: none"> <li>1. Loose pump belt.</li> <li>2. Low oil level in reservoir.</li> </ol> <p>NOTE: Low oil level will also result in excessive pump noise.</p> <ol style="list-style-type: none"> <li>3. Steering gear to column misalignment.</li> <li>4. Lower coupling flange rubbing against steering gear adjuster plug.</li> <li>5. Tires not properly inflated.</li> </ol> <p>Further possible causes could be:</p> <ol style="list-style-type: none"> <li>6. Sticky flow control valve.</li> <li>7. Insufficient pump pressure output.</li> <li>8. Excessive internal pump leakage.</li> <li>9. Excessive internal gear leakage.</li> </ol>	<ol style="list-style-type: none"> <li>1. Adjust belt tension to specification.</li> <li>2. Fill to proper level. If excessively low, check all lines and joints for evidence of external leakage. Tighten loose connectors to 30-ft-lbs.</li> <li>3. Align steering column.</li> <li>4. Loosen pinch bolt and assemble properly.</li> <li>5. Inflate to recommended pressure.</li> </ol> <p>In order to diagnose conditions such as listed in 6, 7, 8, 9 a test of the entire power steering system is required.</p>

**STEERING GEAR AND PUMP DIAGNOSIS CHART (Cont'd.)****POWER STEERING SYSTEM TEST PROCEDURE**

1. Disconnect pressure hose at union of pump, use a small container to catch any fluid which might leak.
2. Connect a spare pressure hose to pump union.
3. Using pressure gage J 5176-1, adapter fitting J 22326, connect gage to both hoses.
4. Open hand valve on gage.
5. Start engine, allow system to reach operating temperatures and check fluid level adding any fluid if required. When engine is at normal operating temperature, the initial pressure read on the gage (valve open) should be in the 80-125 psi range. Should this pressure be in excess of 200 psi—check the hoses for restrictions and the poppet valve for proper assembly.
6. Close gate valve fully 3 times. Record the highest pressures attained each time. (Note: do not leave valve fully closed for more than 5 seconds as the pump could be damaged internally).
  - (a) If the pressures recorded are within 1250-1350 psi and the range of readings are within 50 psi, the pump is functioning within specs.
  - (b) If the pressures recorded are high, but do not repeat within 50 psi, the flow controlling valve is sticking. Remove the valve, clean it and remove any burrs using crocus cloth or fine hone. If the system contains some dirt, flush it. If it is exceptionally dirty, both the pump and the gear must be completely disassembled, cleaned and reassembled before further usage.
  - (c) If the pressures recorded are constant, but more than 100 psi, below the low listed spec., replace the flow control valve and recheck. If the pressures are still low, replace the rotating group.
7. If the pump checks to specs., leave the valve open and turn (or have turned) the steering wheel into both corners. Record the highest pressures and compare with the maximum pump pressure recorded. If this pressure cannot be built in either (or one) side of the gear, the gear is leaking internally and must be disassembled and repaired.
8. Shut off engine, remove testing gage, spare hose, reconnect pressure hose, check fluid level or make needed repairs.



## STEERING GEAR AND PUMP DIAGNOSIS CHART (Cont'd.)

Condition	Possible Cause	Correction
Foaming milky power steering fluid, low fluid level and possible low pressure.	1. Air in the fluid, and loss of fluid due to internal pump leakage causing overflow.	1. Check for leak and correct. Bleed system. Extremely cold temperatures will cause system aeration should the oil level be low. If oil level is correct and pump still foams, remove pump from vehicle and separate reservoir from housing. Check welsh plug and housing for cracks. If plug is loose or housing is cracked, replace housing.
Low pressure due to steering pump.	1. Flow control valve stuck or inoperative. 2. Pressure plate not flat against cam ring. 3. Extreme wear of cam ring. 4. Scored pressure plate, thrust plate or rotor.  5. Vanes not installed properly. 6. Vanes sticking in rotor slots. 7. Cracked or broken thrust or pressure plate.	1. Remove burrs or dirt or replace.  2. Correct.  3. Replace parts. Flush system. 4. Replace parts. (If rotor, replace with rotating group kit). Flush system. 5. Install properly.  6. Free-up by removing burrs, varnish or dirt. 7. Replace part.
Low pressure due to steering gear.	1. Pressure loss in cylinder due to worn piston ring or badly worn housing bore. 2. Leakage at valve rings, valve body to worm seal.	1. Remove gear from vehicle for disassembly and inspection of ring and housing bore.  2. Remove gear from vehicle for disassembly and replace seals.

### REMOVAL OF PUMP (FIGURE 7)

1. Loosen power steering and Delcotron belts.
2. Disconnect pressure line and return hose from pump. (Install caps at both pump fittings to prevent drainage of oil from pump.
3. Remove power steering pump mounting bolts and nuts, and upper left venturi bracket. (See figure 7).
4. Remove power steering pump with adjusting link attached.
5. Remove adjusting link from pump.
6. Remove pulley by removing pulley nut and

then using a tool such as J-21239-1 or equivalent remove pulley.

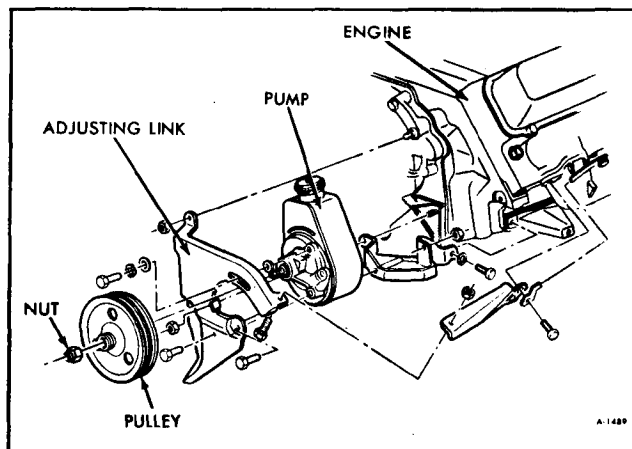

Figure 7—Pump Installation

## PUMP DISASSEMBLY

Before disassembly of pump, remove reservoir filler cap and drain oil from reservoir by inverting the pump so oil may drain out the filler hole.

After oil is drained from reservoir, cap should be replaced and the entire pump assembly washed in a non-toxic solvent to remove all dirt and prevent any foreign matter from contaminating pump components.

1. Clamp front hub of pump in vise so that the extending portion of shaft is directed downward, being careful not to clamp vise too tight as this may distort the bearing (figure 8).

2. Using proper sized wrenches, remove union and "O" ring assembly and both mounting studs from back of reservoir. Discard all seals and "O" rings. (figure 8).

3. Reservoir may then be removed from housing by rocking it slightly back and forth to unseat the "O" ring. Remove "O" ring and discard.

4. Remove both mounting stud and union seals from counterbored spaces between reservoir and housing. Discard these seals also. (figure 9).

5. Remove the end plate retaining ring by inserting a small punch in the 1/8 inch diameter hole in the housing side opposite the flow control valve hole. Compress the retaining ring with the punch and remove by inserting a screwdriver under the ring and twisting the screwdriver. (figure 10).



Figure 8—Studs & Union Being Removed

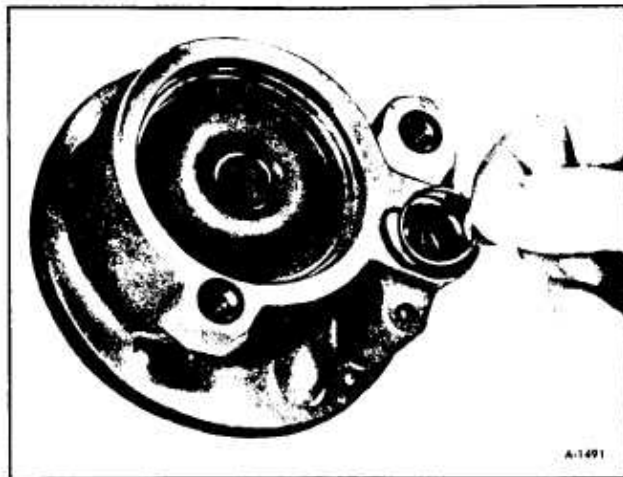

Figure 9—Removal of Stud & Union Seals

6. Remove end plate and end plate "O" ring. End plate is spring loaded and will generally sit above the housing level for ease of removal. If sticking should occur, a slight rocking action of the end plate should be used to free it. (figure 11).

7. Remove pump from vise and invert. Flow control valve and valve spring will fall free. (figure 12).

8. Remove key from shaft end where pulley was mounted.

9. With end cover "O" ring and shaft key removed, tap very lightly on end of shaft, only until pressure plate falls free. (figure 13).

10. Remove pressure plate, shaft, pump ring, vanes and rotor. (figure 14).

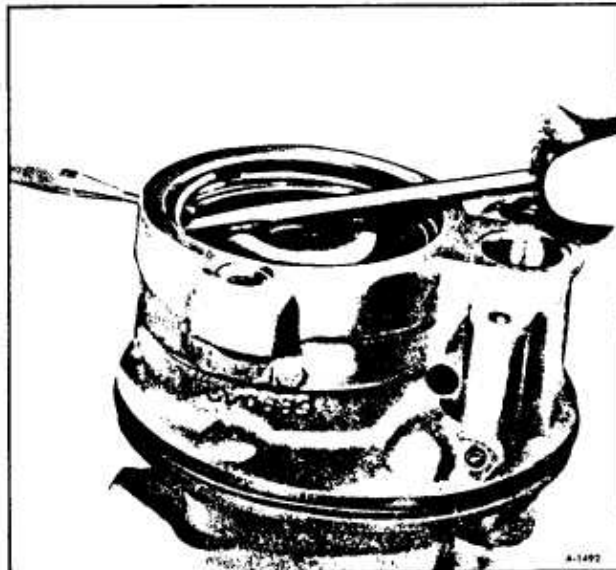

Figure 10—Removal of End Plate Retaining Ring



Figure 11-Removal of End Plate

11. Remove shaft retaining ring and discard. (Some models do not have retaining rings).

12. Remove rotor and thrust plate from shaft and both dowel pins from housing. (figure 15).

13. Pry shaft seal out of housing, being careful not to damage the housing bore; discard the shaft seal.

## CLEANING AND INSPECTION

Carefully clean all pump parts in non-toxic cleaning solvent. Replace any damaged or worn parts.

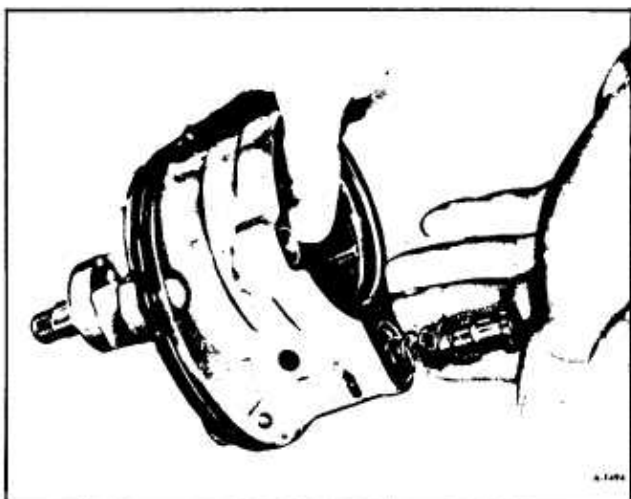

Figure 12-Removal of Relief Valve

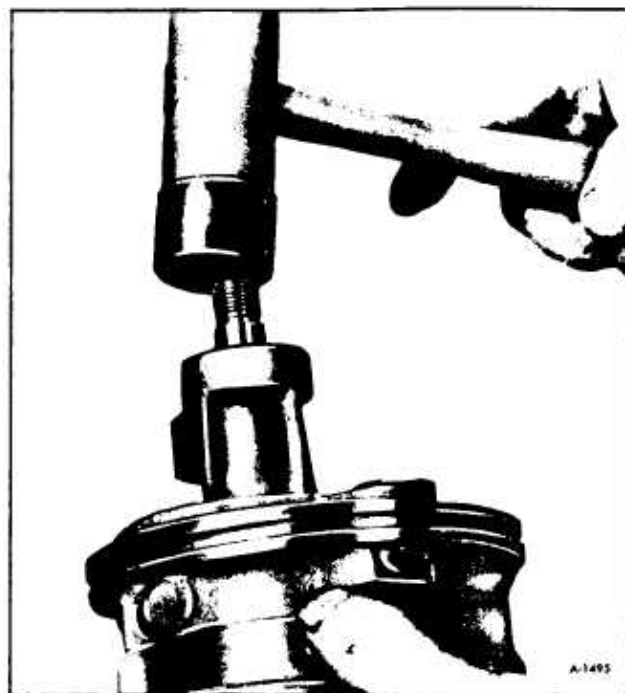

Figure 13-Tapping Shaft to Unseat Pressure Plate

1. Inspect flow control valve assembly for score marks, wear, burrs, or other damage.

2. Inspect castings for cracks or other visual evidences of damage. Check machined surfaces, especially mating surfaces on "O" ring seats, for scratches or burrs that might permit leaks. Examine

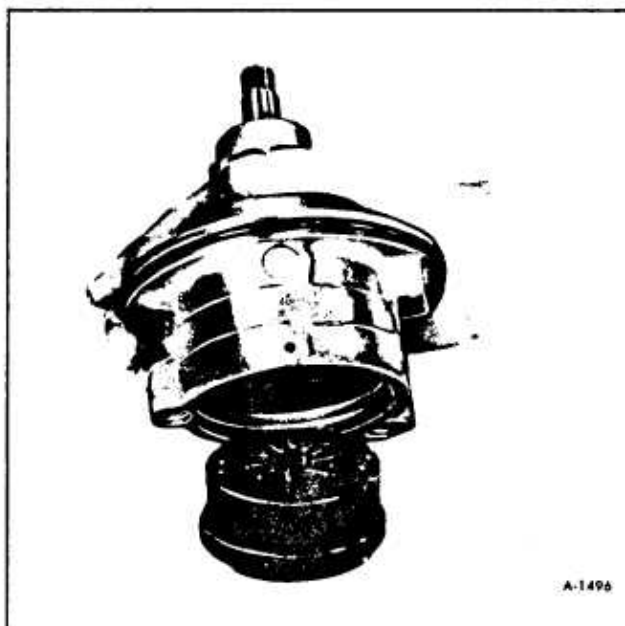

Figure 14-Removal of Shaft, Pressure Plate, Pump Ring, Vanes and Rotor



Figure 15—Removing Dowel Pins From Housing

the V-shaped notches at edges of discharge ports on pressure plate. These notches must be clean and undamaged if pump noise is to be avoided, as they cushion the hydraulic shock when each vane passes the port.

3. Inspect pump ring end surfaces for score marks.

**NOTE:** Pump ring is treated which leaves a dull gray-black finish on wear surface. Wavy grain appearance inside pump ring is normal.

4. Inspect pump shaft for score marks, excessive wear, or damage—particularly at splines, keyway, and at bearing and seal surfaces. Separate and inspect rotor and vanes for wear and general condition.

5. Inspect shaft bushing in pump housing, and replace pump housing if bushing is scored or excessively worn.

6. If any internal parts are found to be worn or damaged, flush steering gear or disassemble gear and clean internal parts.

## ASSEMBLY OF PUMP

1. Install new pump shaft seal using seal protector J-22616 and seal installer J-7728 or a 1 inch socket with an arbor press or hammer. (figure 16). Do not use any more force than necessary to seat the seal.

2. Lubricate new pressure plate "O" ring with

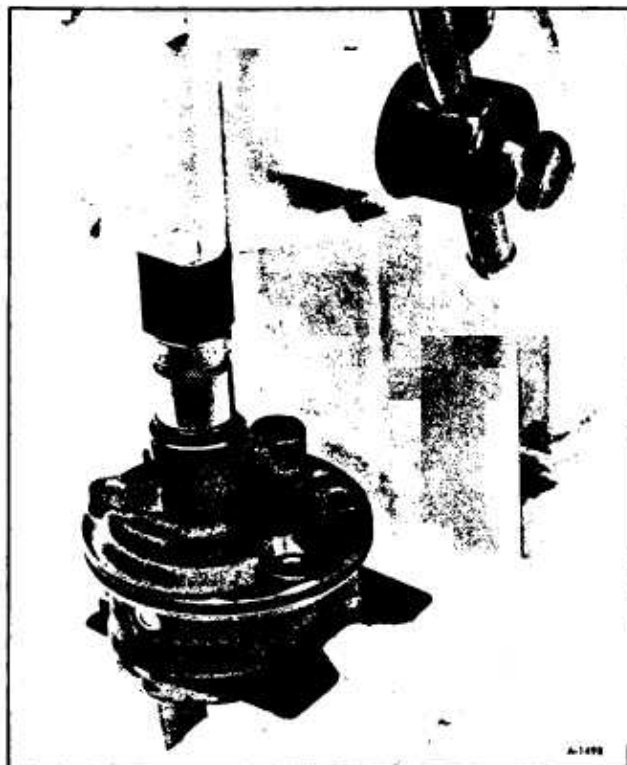

Figure 16—Installing Shaft Seal

Power Steering Fluid, and install in third groove from rear of housing.

3. Clamp end hub of housing in vise in same position as before and insert both dowel pins. (figure 15). Do not over tighten the vise—damage to the bearing could occur.

4. Insert shaft through thrust plate and rotor, and install new snap ring on shaft. Open the snap ring just enough to slide over the end of shaft. (Rotor must have counter sunk side toward thrust plate.) (figure 17).

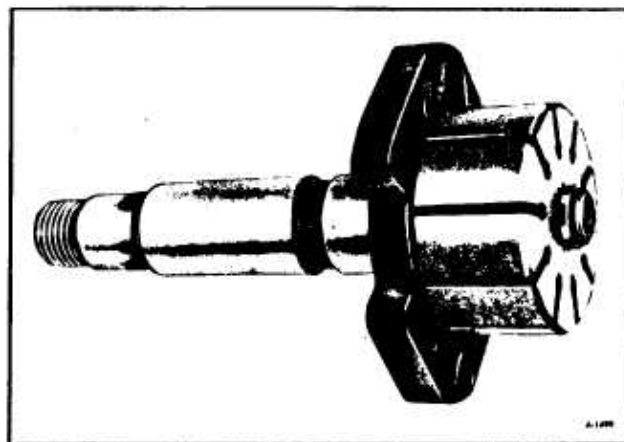

Figure 17—Shaft With Thrust Plate and Rotor

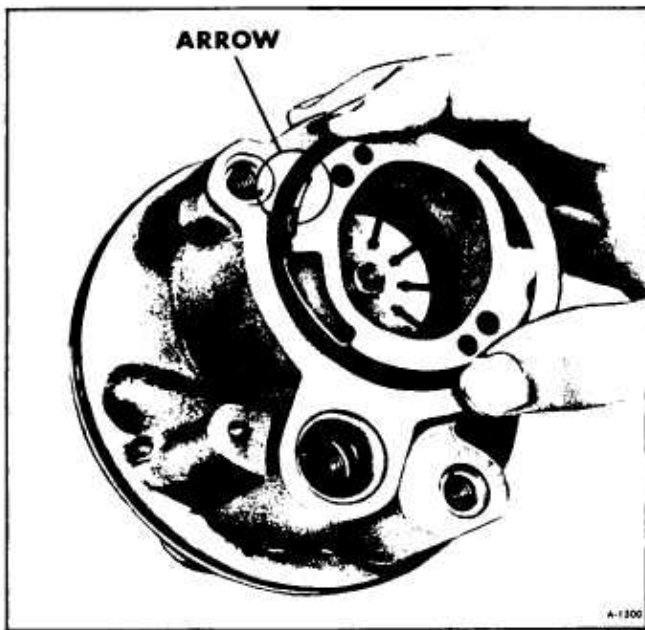

Figure 18—Pump Ring Showing Arrow

5. Insert shaft in housing, making sure thrust plate slides properly on dowel pins.

6. Install pump ring on dowel pins with the arrow toward rear of housing (figure 18).

7. Install all ten vanes in rotor slots with rounded edge of vanes outward (figure 3 and 19). Vanes should slide freely.

8. Lubricate pressure plate with Power Steering Fluid so as not to damage pressure plate "O" ring.



Figure 19—Replacement of Pump Vanes



Figure 20—Installing Pressure Plate

9. Install pressure plate on dowel pins with circular depression for spring toward rear of housing. Pressure plate must be pressed about 1/16 inch over the "O" ring to seat (figure 20).

10. Lubricate new end plate "O" ring with Power Steering Fluid and install in second groove from rear of housing.

11. Install end plate spring in groove provided in pressure plate (figure 11).

12. Lubricate end plate with Power Steering Fluid so as not to damage "O" ring and press into housing with an arbor press (figure 21). Depress only far enough to enable retaining ring to seat properly in groove.

13. Install end plate retaining ring and release arbor press.

14. Place flow control valve spring in hole first and then insert flow control valve with screened end toward front of housing.

15. Install new stud seals and union seals in counter sunk holes, and lubricate with Power Steering Fluid and install new reservoir "O" ring on housing (figure 9).

16. Lubricate inside edge of reservoir with Power Steering Fluid and install on housing being careful to align holes at the same time.

17. Insert both stud bolts and tighten with proper sized wrenches (25-40 ft. lb.) (figure 8).

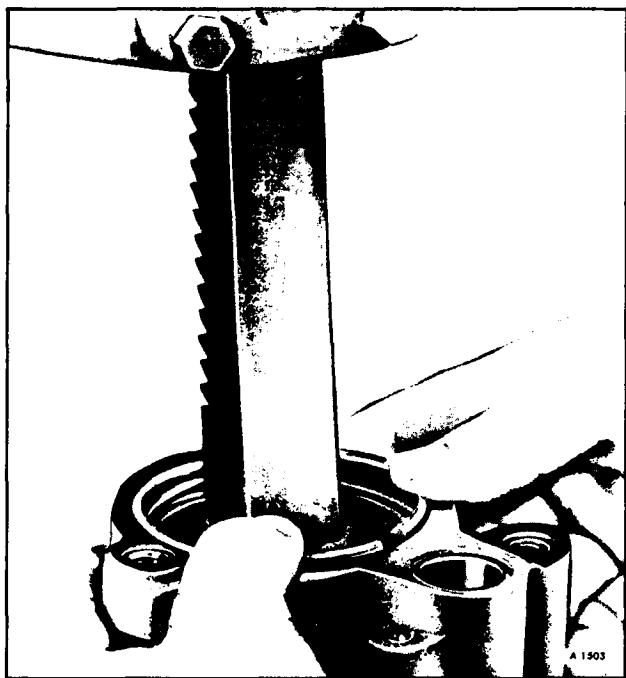

Figure 21—Installation of End Plate Retaining Spring

18. Install new “O” ring on union and lubricate with Power Steering Fluid. Make sure “O” ring is in the groove next to the head hex. Insert union in flow control valve hole in back of reservoir and tighten with proper size wrenches (25-40 ft. lbs.) (figure 8).

19. Install key in shaft end. Support the shaft on the opposite side of the key way and tap the key lightly into place with plastic hammer.

## INSTALLATION OF PUMP (FIGURE 7)

1. Install adjusting link on pump.

2. Slide pulley on shaft. Do not hammer pulley on, as this will damage internal pump parts. Install pulley nut finger tight against pulley. (Always use a new nut).

3. Install pump assembly on engine and secure with bolts and nuts and install venturi bracket.

4. Connect and tighten hose fittings to 30-40 foot-pounds.

5. Fill reservoir with fluid.

Bleed pump by turning pulley backward (counterclockwise as viewed from front) until air bubbles cease to appear.

6. Install pump belts over pulley.

7. Move pump until belts are tight, then tighten adjusting screws. Do not pry on reservoir or pull on filler neck.

8. Torque pulley nut to 50-70 foot pounds.

9. Adjust belts. (Refer to ADJUSTMENTS).

10. Bleed system. (Refer to FLUID LEVEL under ADJUSTMENTS).

## ADJUSTMENTS

### FLUID LEVEL

1. Run engine until Power Steering Fluid reaches normal operating temperature, approximately 170°F., then shut engine off. Remove reservoir filler cap and check oil level on dipstick.

2. If oil level is low, add Power Steering Fluid to proper level on dipstick and replace filler cap.

**NOTE:** When adding or making a complete fluid change, always use special power steering fluid available from servicing parts warehouses.

3. When checking fluid level after the steering system has been serviced, air must be bled from the system. Proceed as follows:

a. With wheels turned all the way to the left, add power steering fluid to “Cold” mark on dipstick.

b. Start engine, and running at fast idle, recheck fluid level. Add fluid if necessary to “Cold” mark on dipstick.

c. Bleed system by turning wheels from side to side without hitting stops. Maintain fluid level just above internal pump casting. Fluid with air in it will have a light tan or red appearance. This air must be eliminated from fluid before normal steering action can be obtained.

d. Return wheels to center position and continue to run engine for two or three minutes then shut engine off.

e. Road test car to make sure steering functions normally and is free from noise.

f. Recheck fluid level as described in steps 1 and 2, making sure fluid level is at “Hot” mark on dipstick after the system has stabilized at its normal operating temperature.



## BELT ADJUSTMENT

When adjusting a power steering pump belt, never pry against the pump reservoir or pull against the filler neck. To increase belt tension move the pump outward by prying against the bracket pry lugs or against the pump housing casting extension directly behind the pump drive pulley.

A belt that has been previously tensioned is considered to be a used belt and should be tightened to 70 to 80 pounds. A belt that has never been tensioned is considered to be a new belt and should be tightened to 110 to 140 pounds.

Place belt tension gauge J-23600 or equivalent midway between the pulleys on drive belt being checked. If the belt tension is incorrect proceed as follows:

### ADJUSTING BELT TENSION

1. When power steering pump is driven by a single belt.

a. Loosen the pump attaching bolts and adjust the belt to correct tension by moving the pump outward, away from the engine.

b. Snug all pump mounting bolts and remove pry bar.

c. Tighten all pump mounting bolts to specified torque.

d. Check belt tension and remove the belt tension gage.

2. When the power steering pump pulley is driven by one primary belt and is used as an idler for a second belt driving some other auxiliary:

a. Follow same checking and adjusting procedure for the primary power steering pump drive belt as for 1 above.

b. Recheck and adjust as necessary the pump belt tension after adjusting tension on belt driving the auxiliary.

# STEERING GEAR

## GENERAL INFORMATION

The integral power steering gear has an open center, rotary type, three-way control valve, which directs oil to either side of the rack piston. The rack piston converts hydraulic power into mechanical output. The steering gear is mounted on the left frame rail by four mounting bolts. The steering shaft is joined to the steering gear through a flexible coupling, which reduces the transmission of hydraulic noise to the steering wheel.

A constant displacement pump provides hydraulic pressure for the steering system. The pump is a pulley driven vane type having an oil reservoir, which is part of the pump. It is attached to the front of the engine by a bracket, and is belt driven from an engine crank shaft pulley.

## OPERATION

### NEUTRAL (STRAIGHT AHEAD POSITION)

When turning effort is not being applied at the steering wheel, the slots in the spool valve are positioned so that oil entering the valve body from the housing pressure port passes through the slots in the

spool valve to the oil return port in the housing. The chambers at both ends of the rack-piston and around the pitman shaft are always full of oil, which acts as a cushion to absorb road shock so that they are not transferred to the driver. In addition, this oil lubricates all the internal components of the gear.

### RIGHT TURN

When the steering wheel is turned to the right, the worm resists being turned because of the resistance offered by the front wheels. The valve body also resists turning because it is pinned to the worm. Driver force exerted at the steering wheel turns the stub shaft and spool valve a slight amount in relation to the valve body because of the twisting action of the torsion bar. This slight amount of turning of the spool valve is sufficient to position the slots in the valve body and spool valve for power assist.

The right turn slots in the spool valve are closed off from the return (wide) slots in the valve body and opened more to the pressure (narrow) slots in the valve body. The left turn slots in the spool valve are closed off from the pressure slots in the valve body and opened more to the return slots in the valve body.

Pressure immediately begins to build up against the lower end of the rack-piston, forcing it upward to apply turning effort to the pitman shaft. The oil in the chamber at the upper end of the rack-piston is then forced out through the valve body and spool valve through the oil return port to the pump reservoir.

The instant the driver stops applying turning effort to the steering wheel, the spool valve is forced back into its neutral position by the torsion bar. Oil pressure on the lower end of the rack-piston then decreases so that pressure is again equal on both sides of the rack-piston, and the front wheels return to the straight ahead position, when the vehicle is moving.

Under normal driving conditions, oil pressure does not exceed 200 psi except when turning corners where it does not ordinarily exceed 450 psi. Oil pressure, when parking, ranges from 900 to 1,300 psi depending upon road conditions and weight of the vehicle. The steering effort during normal driving, ranges from 1 to 2 lbs. and during parking from 2 to 3-1/2 lbs. again depending upon road conditions.

A check valve located under the high pressure connector seat hydraulically dampens the shock transmitted to the steering gear when driving on washboard roads.

## LEFT TURN

When the steering wheel is turned to the left, the relationship between the spool valve slots and valve body slots is again changed through twisting of the torsion bar. Pressure immediately builds up against the upper end of the rack-piston, forcing it downward to apply turning effort to the pitman shaft. The oil in the chamber at the lower end of the rack-piston is forced out through the valve body and spool valve to the pump reservoir.

## TROUBLE DIAGNOSIS

For complete power steering trouble diagnosis see TROUBLE DIAGNOSIS under POWER STEERING PUMP earlier in this section.

## STEERING GEAR REMOVAL

1. Disconnect the power steering hoses from the steering gear and cap the hose fittings.

2. Remove the pitman arm shaft nut. Mark the relation of the pitman arm to the pitman shaft. Disconnect the pitman arm from the pitman shaft using tool number J-24319 or similar puller.

3. Loosen steering shaft yoke cinch bolt.

4. Remove the four bolts attaching the gear to the frame side rail, permit the steering shaft yoke to slide free of the steering gear stub shaft and remove the gear.

## STEERING GEAR OVERHAUL

Disassembly of the major components within the gear must be performed on a clean work bench. The work area, tools, and parts must be kept clean at all times. Refer to Figures 22 and 23 for parts nomenclature and location.

## STEERING GEAR DISASSEMBLY

1. Rotate end cover retainer ring so that one end of the ring is over the hole in the side of the housing. Force the end of the ring from its groove and remove ring (figure 24).

2. Turn the coupling flange counter-clockwise until the rack-piston just forces end cover out of housing. Remove cover and discard "O" ring.

**CAUTION:** Do not turn stub shaft any further than absolutely necessary to remove the end plug, or balls from rack-piston and worm circuit may escape and lay loose inside the rack-piston chamber.

3. Remove the rack-piston end plug as shown in Figure 25.

**NOTE:** To aid in loosening the aluminum end plug (female square drive) strike sharply using 1" diameter brass drift or larger and hammer.

4. Remove the pitman shaft and side cover as follows:

a. Loosen the over-center adjusting screw locknut and remove the 4 side cover attaching bolts.

b. Rotate the side cover until the rack-piston and pitman shaft teeth are visible, then turn the coupling flange until the pitman shaft teeth are centered in the housing opening. Tap the pitman shaft with a soft hammer and remove the pitman shaft and side cover from the housing. Remove the side cover "O"



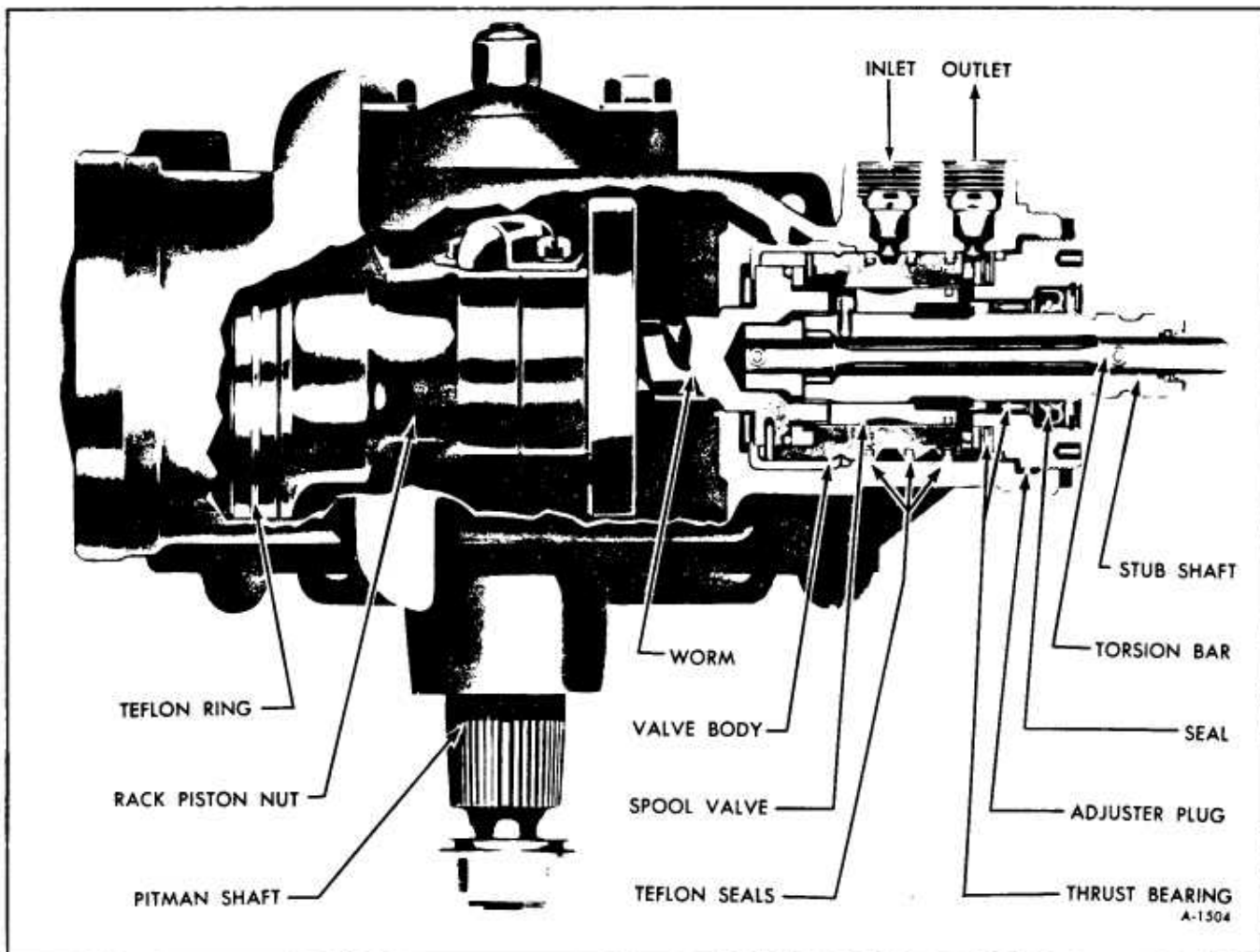

Figure 22—Power Steering Gear

ring and discard. If gasket seal is used, inspect, discard only if damaged.

5. Remove the rack-piston as follows:

a. Insert Ball Retainer Tool J-21552 into the rack-piston bore with pilot of tool seated in the end of the worm (figure 26). Turn stub shaft counterclockwise while holding tool tightly against worm. The rack-piston will be forced onto the tool. Hold tool and pull rack-piston farther onto tool to prevent end circuit balls from falling out.

b. Remove the rack-piston with Ball Retainer Tool J-21552 from gear housing.

6. Remove the adjuster plug as follows:

a. Loosen the adjuster plug locknut and remove.

b. Remove adjuster plug assembly with Spanner Wrench J-7624 (figure 27). Remove and discard the adjuster plug "O" ring.

7. Grasp the stub shaft and pull the valve assembly from the housing bore. Separate worm and valve and remove the lower shaft cap "O" ring and discard.

8. If the worm or the lower thrust bearing and race remained in the gear housing, remove them at this time.

## ADJUSTER PLUG ASSEMBLY

### Disassembly

1. If the oil seal ONLY is to be replaced, and not the bearing, install the adjuster plug (figure 28)

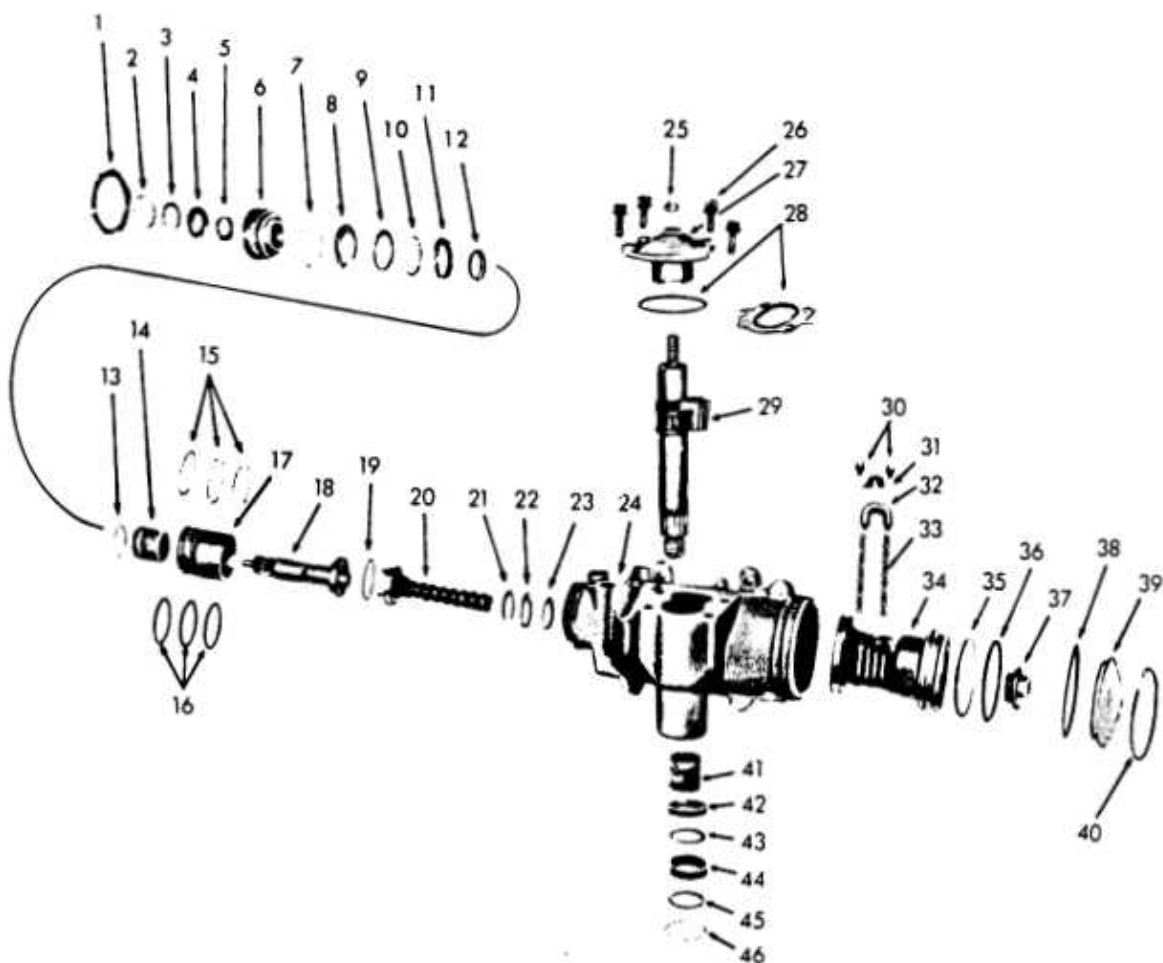

- 1 Locknut
- 2 Retaining Ring
- 3 Dust Seal
- 4 Oil Seal
- 5 Bearing
- 6 Adjuster Plug
- 7 "O" Ring
- 8 Thrust Washer (Large)
- 9 Thrust Bearing
- 10 Thrust Washer (Small)
- 11 Spacer
- 12 Retainer
- 13 "O" Ring
- 14 Spool Valve
- 15 Teflon Oil Rings
- 16 "O" Rings

- 17 Valve Body
- 18 Stub Shaft
- 19 "O" Ring
- 20 Wormshaft
- 21 Thrust Washer
- 22 Thrust Bearing
- 23 Thrust Washer
- 24 Housing
- 25 Locknut
- 26 Attaching Bolts and Washers
- 27 Side Cover
- 28 "O" Ring
- 29 Pitman Shaft
- 30 Screws and Lock Washers
- 31 Clamp

- 32 Ball Return Guide
- 33 Balls
- 34 Rack-Piston
- 35 Teflon Oil Seal
- 36 "O" Ring
- 37 Plug
- 38 "O" Ring
- 39 Housing End Cover
- 40 Retainer Ring
- 41 Needle Bearing
- 42 Oil Seal
- 43 Back Up Washer
- 44 Oil Seal
- 45 Back Up Washer
- 46 Retaining Ring

A-1505

Figure 23-Steering Gear (Exploded View)

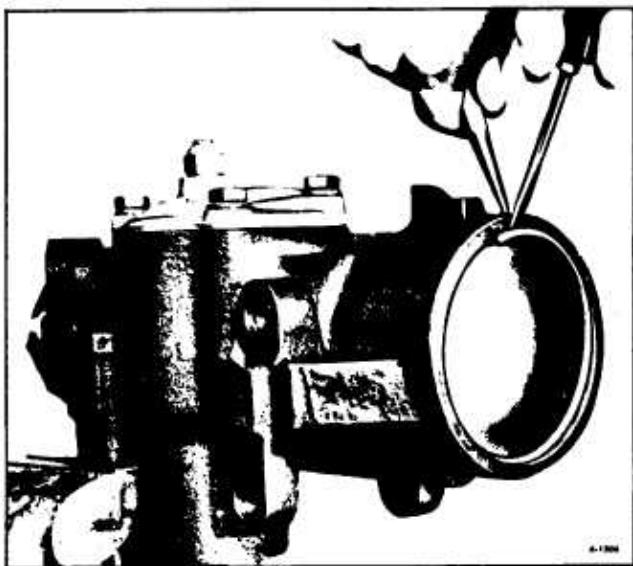

Figure 24—Removing End Cover

loosely in the gear housing. Remove the retaining ring with Internal Pliers J-4245. With a screw driver, pry the dust seal and oil seal from the bore of the adjuster plug being careful not to score the seal bore. Discard the oil seal.

2. If the thrust bearing **ONLY** is to be removed, pry the thrust bearing retainer at the two raised areas with a small screw driver (figure 29). Remove the spacer, thrust bearing washer, thrust bearing and washer.

3. If the needle bearing is to be replaced, remove the retaining ring using Internal Pliers J-4245. Remove thrust bearing as outlined in Step 2 above. Drive needle bearing, dust seal and oil seal from adjuster plug using Bearing Remover J-8524-2 and Driver J-7079-2 as shown in Figure 30. Discard the seals.

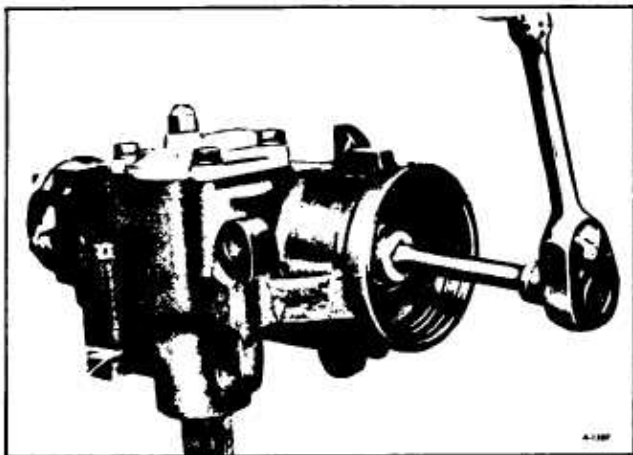

Figure 25—Removing Rack-Piston End Plug



Figure 26—Removing Rack Piston

4. Wash all parts in clean solvent and dry parts with compressed air.

5. Inspect thrust bearing spacer for wear or cracks. Replace if damaged.

6. Inspect thrust bearing rollers and thrust washers for wear, pitting or scoring. If any of these conditions exist, replace the bearing and thrust washers.

#### Assembly

1. If the needle bearing was removed, place new needle bearing over Tool J-8524-1 and J-7079-2, with the bearing manufacturer's identification against the tool, and drive the bearing into the adjuster plug until the tool bottoms in the housing (figure 31).

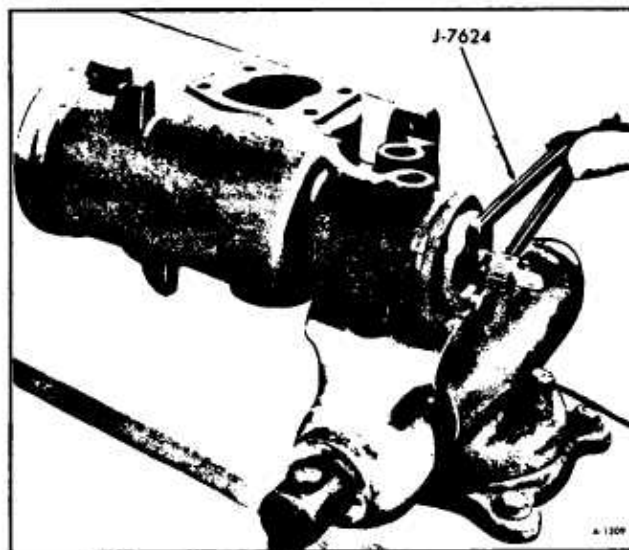

Figure 27—Removing Adjuster Plug

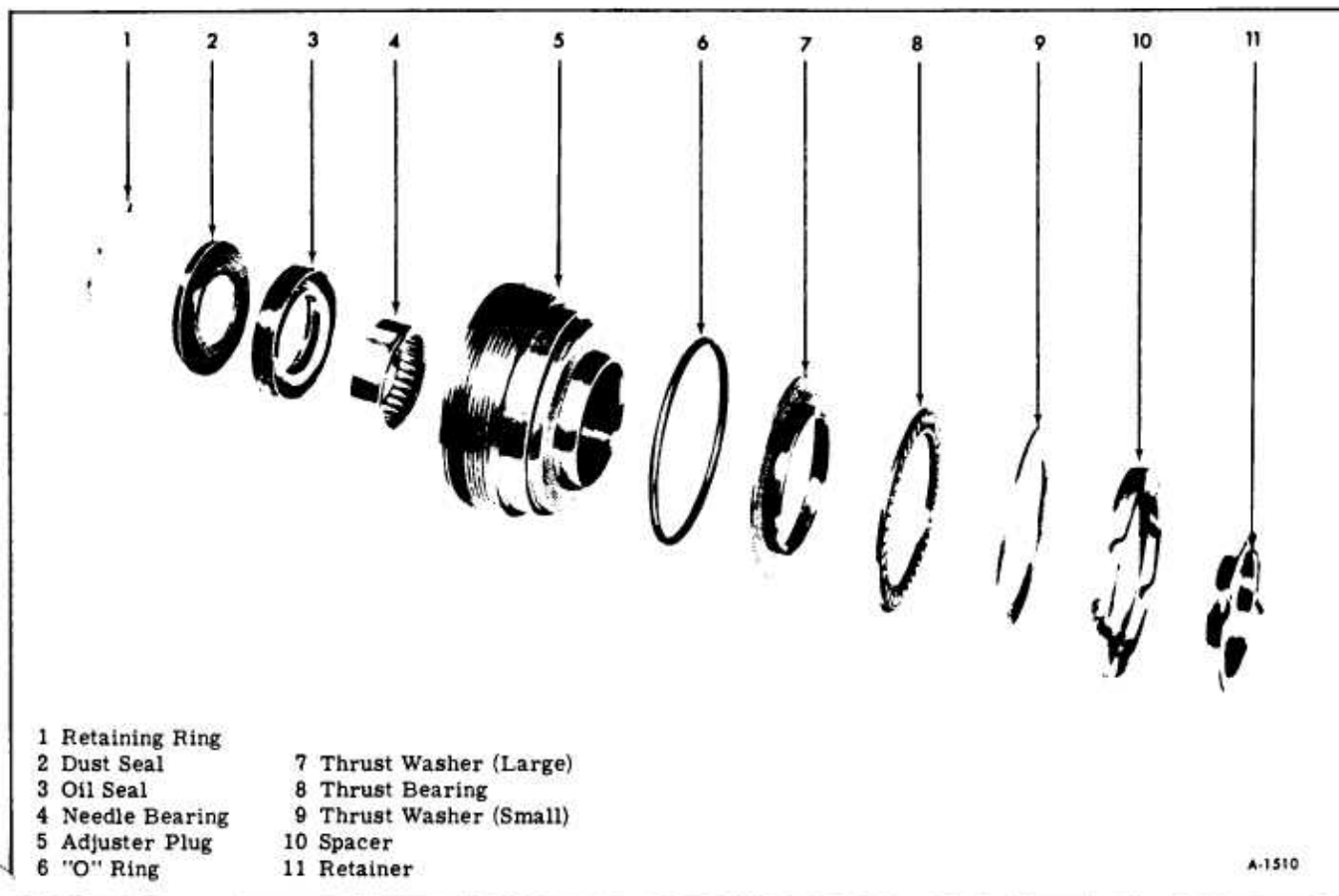

Figure 28—Adjuster Plug (Exploded View)

**CAUTION:** Place a block of wood under the adjuster plug to protect it during driving of the bearing.

2. Place dust seal and a new oil seal on Tool J-8524-1 (lip of seal away from tool). Lubricate seal

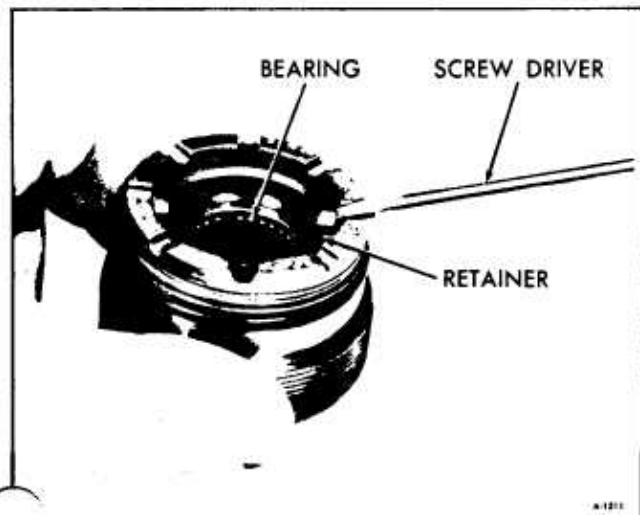

Figure 29—Removing Retainer

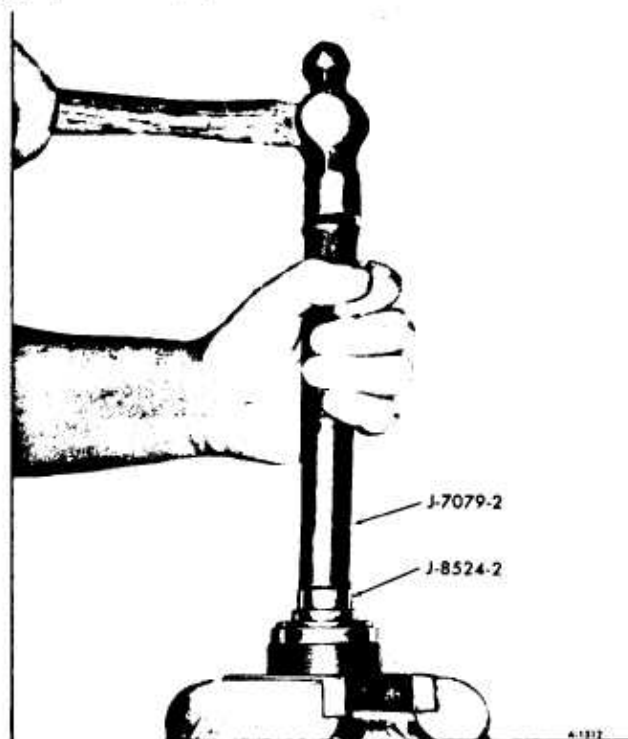

Figure 30—Removing Bearing and Seal

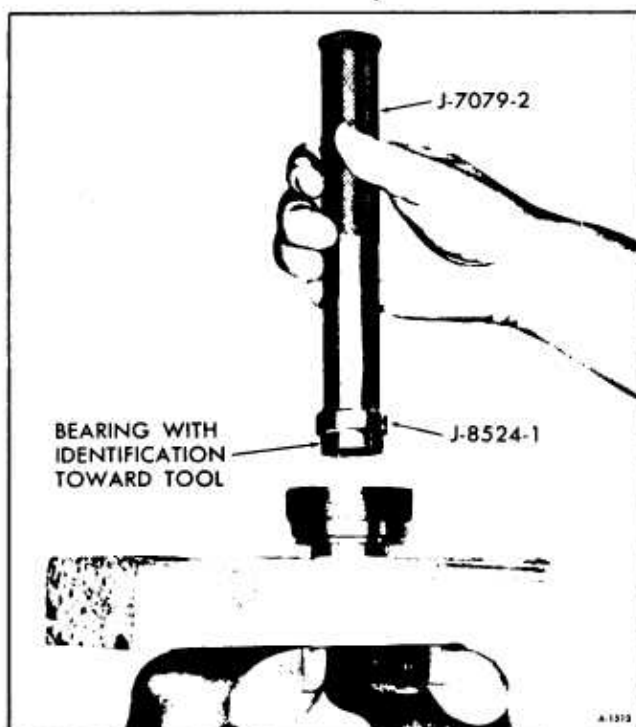

Figure 31—Installing Bearing

with Power Steering Fluid and drive or press seals into adjuster plug until seated (figure 32). When properly installed the oil seal is under the dust seal.

3. Install retaining ring with Internal Pliers J-4245.

4. Lubricate the thrust bearing assembly with Power Steering Fluid. Place the flanged thrust bearing washer on the adjuster plug hub, then install the upper thrust bearing, small bearing washer and spacer (grooves of spacer away from bearing washer).

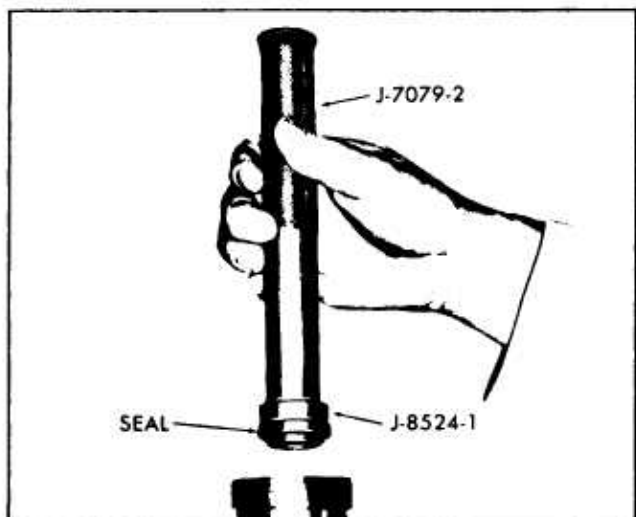

Figure 32—Installing Adjuster Plug Seal

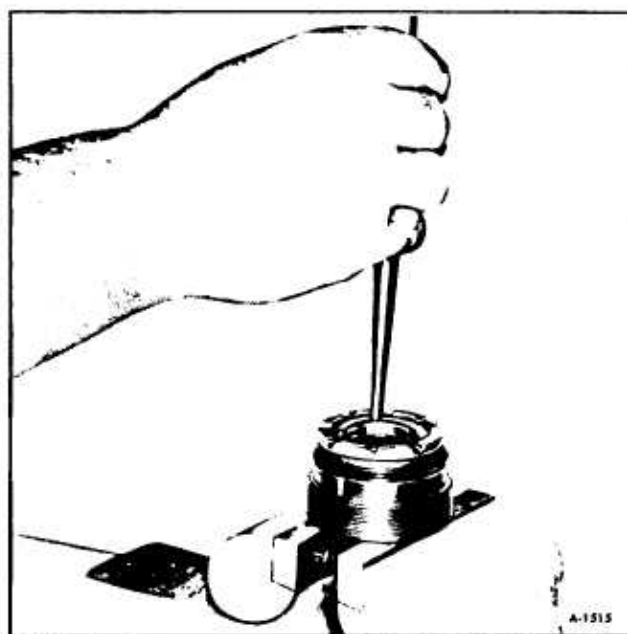

Figure 33—Install Retainer

5. Install bearing retainer on the adjuster plug by carefully tapping on the flat surface of the retainer (figure 33).

**NOTE:** The projections must not extend beyond the spacer when the retainer is seated. The spacer must be free to rotate.

## VALVE AND STUB SHAFT ASSEMBLY

### Disassembly

1. Remove and discard "O" ring in the shaft cap end of the valve assembly.

2. To remove the stud shaft assembly from the valve body, proceed as follows:

a. While holding the assembly (stub shaft down), lightly tap the stub shaft against the bench until the shaft cap is free from the valve body (figure 34).

b. Pull the shaft assembly until the shaft cap clears the valve body approximately 1/4".

**CAUTION:** Do not pull the shaft assembly out too far or the spool valve may become cocked in the valve body.

c. Carefully disengage the shaft pin from the valve spool and remove the shaft assembly (figure 34).

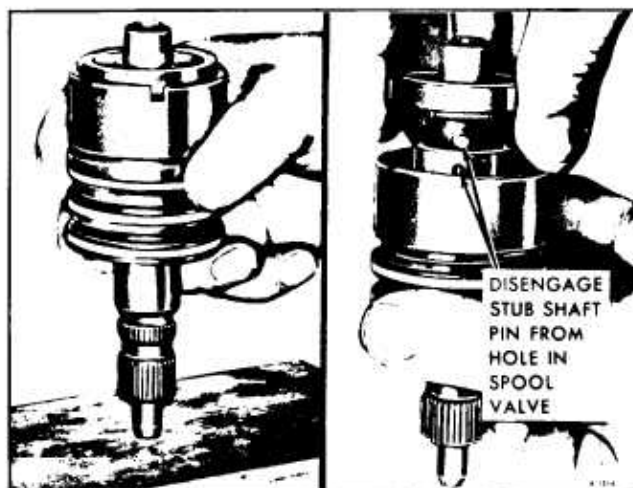

Figure 34—Removing Shaft Cap from Valve Body

3. Push the spool valve out of the flush end of the valve body until the dampener "O" ring is exposed then carefully pull the spool from the valve body, while rotating the valve (figure 35). If the spool valve becomes cocked, carefully realign the spool valve, then remove.

4. Remove the dampener "O" ring from the spool valve and discard.

5. If the teflon oil rings are to be replaced, cut the 3 teflon oil rings and "O" rings from the valve body and discard.



Figure 35—Removing Spool Valve

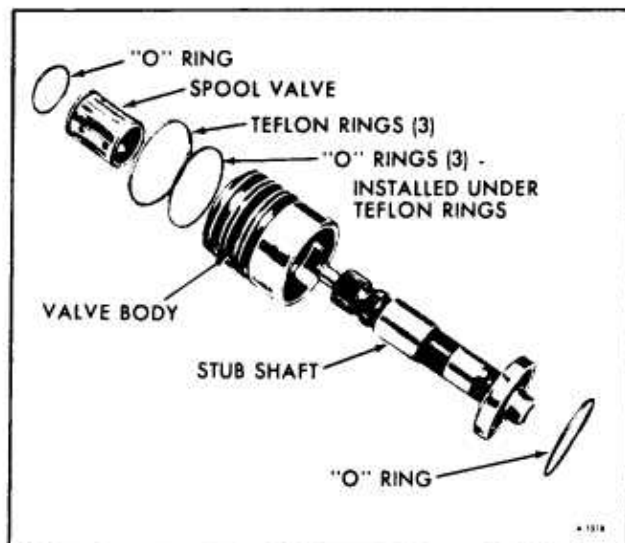

Figure 36—Valve Body and Shaft Assembly

### Cleaning and Inspection (Figure 36)

1. Wash all parts in clean solvent and blow out all oil holes with compressed air.

2. If the drive pin in the stub shaft or valve body is cracked, excessively worn or broken, replace the complete valve and shaft assembly.

3. If there is evidence of leakage between the torsion bar and the stub shaft or scores, nicks, or burrs on the ground surface of the stub shaft that cannot be cleaned up with crocus cloth, the entire valve assembly must be replaced.

4. Check the outside diameter of the spool valve and the inside diameter of the valve body for nicks, burrs, or bad wear spots. If the irregularities cannot be cleaned up by the use of crocus cloth, the complete valve and shaft assembly will have to be replaced.

5. If the small notch in the skirt of the valve body is excessively worn, the complete valve assembly will have to be replaced. See Figure 37.

6. Lubricate the spool valve with Power Steering Fluid and check the fit of the spool valve in the valve body (with the spool valve dampener "O" ring removed). If the spool valve does not rotate freely without binding, the complete valve and shaft assembly will have to be replaced.

### Assembly

1. If valve body "O" rings and teflon rings were removed, install 3 new "O" rings in the oil ring grooves and lubricate with Power Steering Fluid.



NOTCH IN END CAP MUST FULLY ENGAGE PIN PROJECTING INTO VALVE BODY

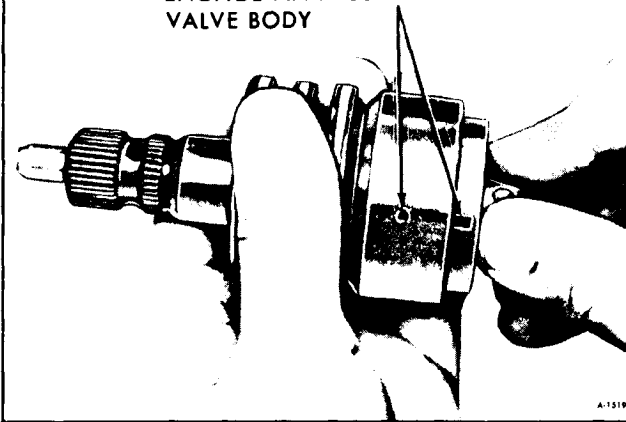

Figure 37—Installing Stub Shaft Assembly

2. Lubricate the 3 new teflon oil rings with Power Steering Fluid and install in grooves over “O” rings.

**NOTE:** The teflon rings may appear to be distorted, but the heat of the oil during operation of the gear will straighten them out.

3. Lubricate the spool valve dampener “O” ring with Power Steering Fluid and install over the spool valve.

4. Lubricate the spool valve and valve body with Power Steering Fluid and slide the spool valve into the valve body. Rotate the spool valve while pushing it into the valve body being careful not to cut the dampener “O” ring. Push the spool valve on through the valve body until the shaft pin hole is visible from the opposite end (spool valve flush with shaft cap end of valve body).

5. Lubricate the shaft assembly with Power Steering Fluid and carefully install it into the spool valve until the shaft pin can be placed into the spool valve.

6. Align the notch in the shaft cap with the pin in the valve body and press the spool valve and shaft assembly into the valve body (figure 37).

**CAUTION:** *Make sure that the shaft cap notch is mated with the valve body pin before installing valve body into the gear assembly.*

7. Lubricate a new cap to body “O” ring with Power Steering Fluid and install it in the shaft cap end of the valve body assembly.

## PITMAN SHAFT AND SIDE COVER

### Disassembly

Remove the locknut and unscrew the side cover from the adjusting screw. Do not attempt to disassemble pitman shaft. Discard locknut.

### Cleaning and Inspection

1. Wash all parts in clean solvent and dry with compressed air.

2. Check pitman shaft bearing surface in the side cover for scoring. If badly worn or scored, replace the side cover assembly.

3. Check the sealing and bearing surfaces of the pitman shaft for roughness, nicks, etc. If minor irregularities in surface cannot be cleaned by use of crocus cloth, replace the pitman shaft.

4. Replace pitman shaft assembly if teeth are damaged or if the bearing surfaces are pitted or scored.

5. Check pitman shaft lash adjusting screw. It must be free to turn with no perceptible end play. If adjusting screw is loose replace the pitman shaft assembly.

### Assembly

Thread the side cover onto the pitman shaft adjusting screw until it bottoms and then turn in 1/2 turn. Install a new adjusting screw locknut, but do not tighten.

## RACK-PISTON

### Cleaning and Inspection

1. Wash all parts in clean solvent and dry with compressed air.

2. Inspect the worm and rack-piston grooves and all the balls for scoring. If either the worm or rack-piston needs replacing, both must be replaced as a matched assembly.

3. Inspect ball return guide halves, making sure that the ends where the balls enter and leave the guides are not damaged.

4. Inspect lower thrust bearing and washers for scoring or excessive wear. If any of these conditions are found, replace the thrust bearing and washers.

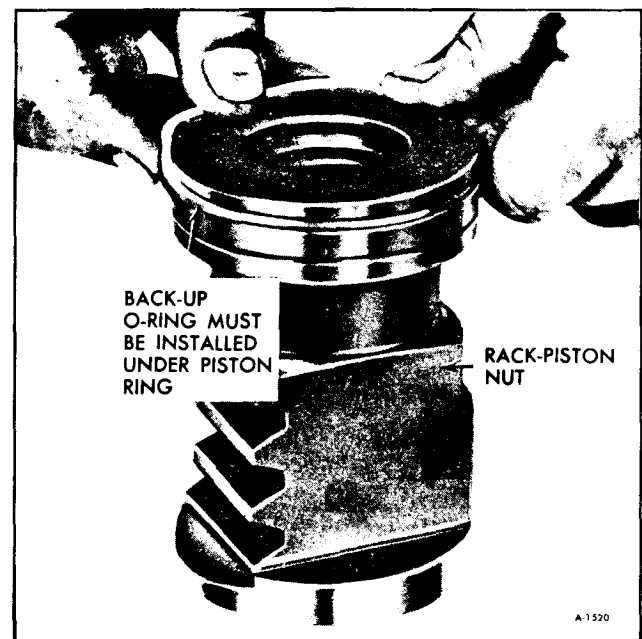

Figure 38—Installing Ring on Rack-Piston

5. Inspect rack-piston teeth for scoring or excessive wear. Inspect the external ground surfaces for wear, scoring or burrs. If any of these conditions exist and are excessive, both the rack-piston and worm must be replaced.

#### Assembly

1. If the teflon oil seal and "O" ring were removed, lubricate a new "O" ring and seal with

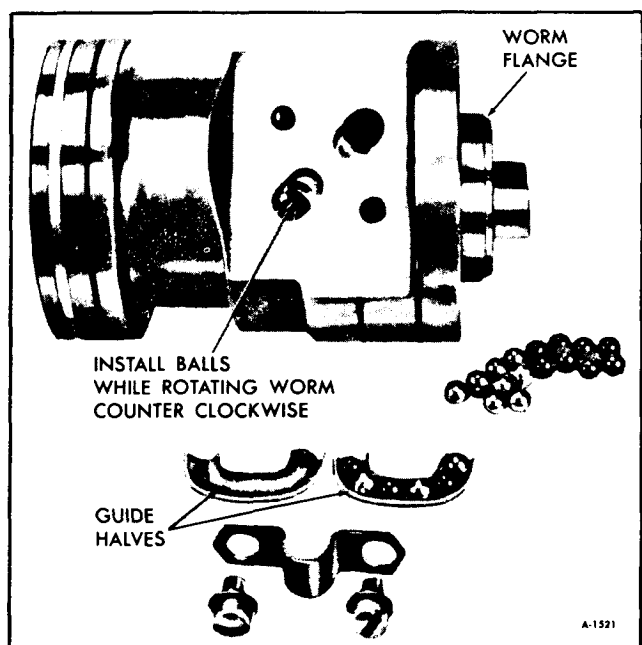

Figure 39—Installing Balls in Rack-Piston

Power Steering Fluid and install in groove on rack-piston. The teflon ring may be slightly loose after assembly, but will tighten up when subjected to the hot oil in the system (figure 38).

2. Slide the worm all the way into the rack-piston. It is not necessary to have the thrust bearing assembly on the worm at this time.

3. Turn the worm until the worm groove is aligned with the lower ball return guide hole (figure 39).

4. Lubricate the balls with Power Steering Fluid, then feed 17 balls into the rack-piston, while slowly rotating the worm counter-clockwise.

**IMPORTANT:** The black balls are .0005" smaller than the silver balls. The black and silver balls must be installed alternately into the rack-piston and return guide.

5. Alternately install 5 balls into the return guide and retain with grease at each end of guide. Install the return guide clamp and tighten the 2 clamp screws to 6 foot pounds.

## STEERING GEAR HOSE CONNECTOR AND POPPET CHECK VALVE REPLACEMENT

The following procedure can be performed on vehicle as well as on bench.

1. Disconnect pressure and return line hoses at steering gear and secure hose ends in a raised position to prevent loss of fluid.

2. To prevent metal chips from becoming lodged in valve assembly, pack inside of connector seats of pressure and return ports with petrolatum.

3. Tap threads in connector seats, using a 5/16-18 tap.

**CAUTION:** Do not tap threads too deep in pressure hose connector seat as tap will bottom poppet valve against housing and damage it. It is necessary to tap only 2 or 3 threads deep.

4. Thread a 5/16-18 bolt with a nut and flat washer into tapped hole (figure 40).

5. To pull connector seat, hold bolt from rotating while turning nut off bolt. This will pull connector from housing. Discard connector seat.



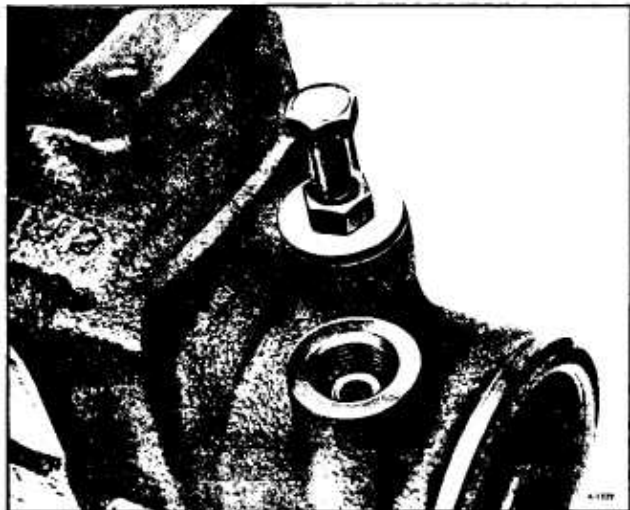

Figure 40—Removing Hose Connector Seat

**NOTE:** It is also possible to remove connector by using a No. 4 screw extractor. (Easy out).

6. Wipe petrolatum from housing and clean housing thoroughly to remove any metal chips or dirt.

7. Remove poppet check valve and spring from pressure port and discard.

8. Install new check valve spring in pressure port with large end down. Make sure spring is seated in counterbore in pressure port (figure 41).

9. Install new check valve over spring with tangs pointing down. Make sure valve is centered on small end of spring.

10. Install new connector seats, using petrolatum to hold connector seat on check valve in pressure

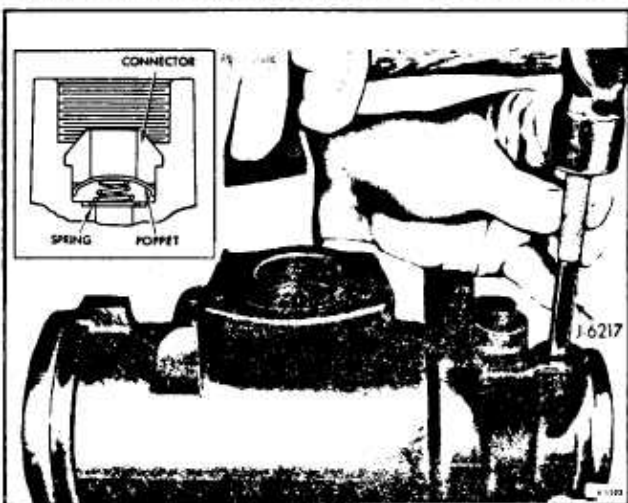

Figure 41—Installing New Connector

port. Drive connector seats in place using Valve Connector Seat Installer, J-6217 (figure 41).

11. Check operation of valve by pushing lightly against valve with a small punch or small rod. Valve should reseat itself against connector seat when pressure is removed from spring.

12. Connect pressure and return line hoses on steering gear. Tighten hose fittings to 30 foot-pounds.

13. Check fluid level in pump reservoir and add if necessary.

## PITMAN SHAFT NEEDLE BEARING AND SEALS

### Removal

**CAUTION:** When prying out seals, be extremely careful not to score the housing bore.

1. If pitman shaft seals ONLY are to be replaced, remove the seal retaining ring with Internal Pliers J-4245 and remove back-up washer. Using screw driver under lip of seal pry out the outer seal. Remove the back-up washer, then pry out the inner seal (figure 42). Discard seals.

2. If pitman shaft needle bearing replacement is necessary, remove with Tool J-6278. Since this bearing is shouldered, it must be pressed out the pitman shaft end of the housing.

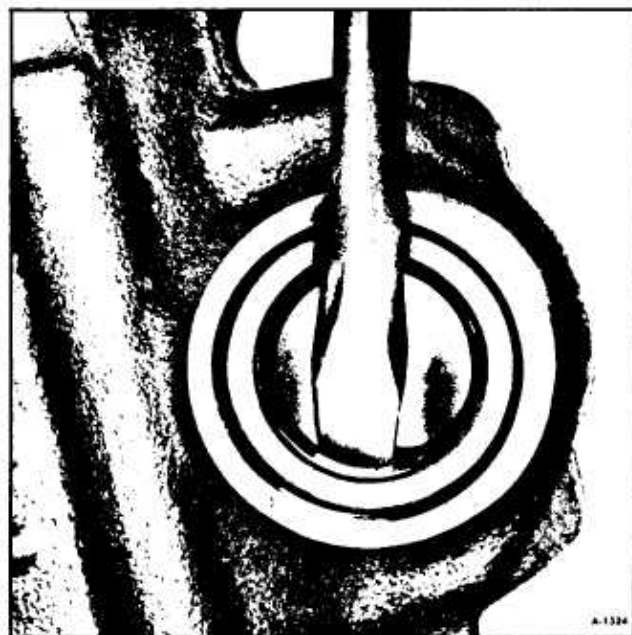

Figure 42—Prying Out Inner Seal

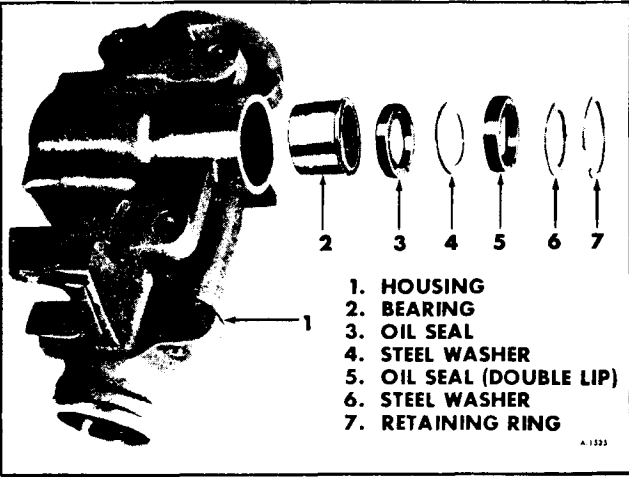

Figure 43-Pitman Shaft Bearing and Seals

**Assembly**

1. Thoroughly clean the parts (figure 43) and lubricate them with Power Steering Fluid.
2. Install pitman shaft needle bearing on Bearing Installer J-22407, with shoulder on bearing against tool. Position bearing and tool in housing and press bearing into housing until bottom edge of bearing is flush with the inner housing bore surface (figure 44).

**CAUTION:** *Do not drive the bearing further into the housing after removing Tool J-22407, since damage to the bearing would result.*

3. Lubricate the lips of the oil seals with Power Steering Fluid.

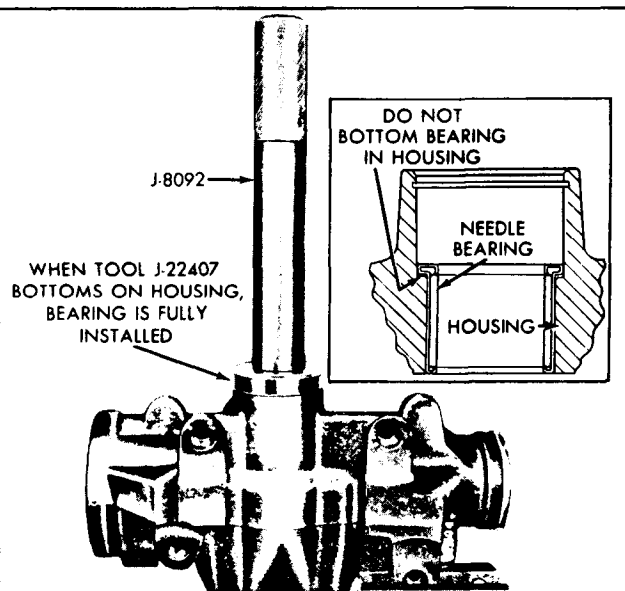

Figure 44-Installing Pitman Shaft Bearing

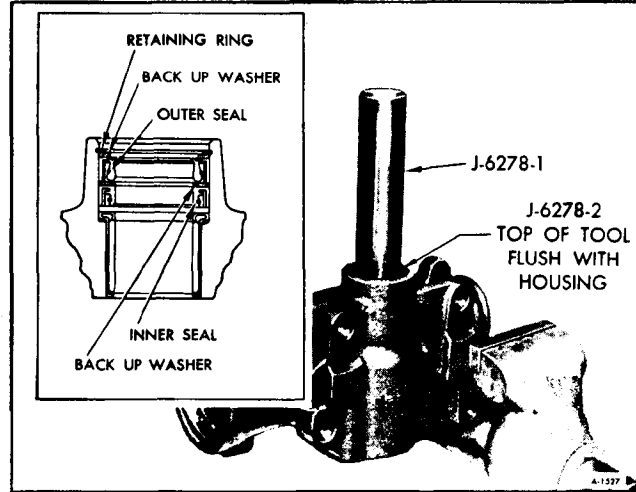

Figure 45-Installing Pitman Shaft Seals

4. Install the pitman shaft oil seals as follows:

- a. Place Adapter J-6278-2 over Tool J-6278, then install the outer seal (double lip), backup washer, and inner seal with the lips of the seals facing away from the adapter. (Seal identification toward adapter.)
- b. Drive the seals into the housing until the top of Adapter J-6278-2 is flush with the housing (figure 45).
- c. Remove the tool and adapter, then install the back-up washer and seal retaining ring. The retaining ring will not seat in the groove at this time.
- d. Reinsert Tool J-6278 with Adapter J-6278-2 and continue driving the seals until the retaining ring seats in its groove (Refer to inset, figure 45), then remove the tool and adapter.

**REPLACEMENT OF PITMAN SHAFT SEALS WITH STEERING GEAR IN VEHICLE**

If upon inspection of the gear, it is found that oil leakage exists at the pitman shaft seals, the seals may often be replaced without removing the gear assembly from the vehicle as follows:

1. Remove pitman nut and disconnect pitman arm from pitman shaft using Puller J-24319. Do not hammer on end of puller.
2. Thoroughly clean end of pitman shaft and gear housing, then tape splines on end of pitman shaft to insure that seals will not be cut by splines during assembly.

**NOTE:** Only one layer of tape should be used; an excessive amount of tape will not allow the seals to pass over it, due to the close tolerance between the seals and the pitman shaft.

3. Remove pitman shaft seal retaining ring with Snap Ring Pliers J-4245.

4. Start engine and turn steering wheel fully to the left so that oil pressure in the housing can force out pitman shaft seals. Turn off engine.

**NOTE:** Use suitable container to catch oil forced out of gear. This method of removing the pitman shaft seals is recommended, as it eliminates the possibility of scoring the housing while attempting to pry seals out.

5. Inspect seals for damage to rubber covering on O.D. If O.D. appears scored, inspect housing for burrs and remove before attempting new seal installation. Check seal surface of pitman shaft for roughness or pitting. If pitted replacement of pitman shaft is recommended.

6. Clean the end of housing thoroughly so that dirt will not enter housing with the installation of the new seals.

7. Lubricate the seals thoroughly with Power Steering Fluid to install seals with Installer J-6219 (figure 46). Install the inner single lip seal first, then a back-up washer. Drive seal in far enough to provide clearance for the outer seal, back-up washer and retaining ring. Make sure that the inner seal does not bottom on the counterbore. Install the outer double lip seal and the second back-up washer in only far

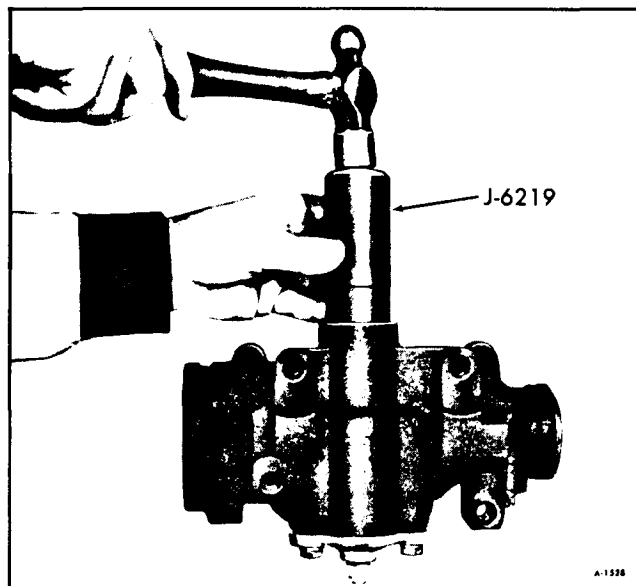

Figure 46—Installing Pitman Shaft Seals

enough to provide clearance for the retaining ring. Install retaining ring.

8. Fill pump reservoir to proper level with Power Steering Fluid. Start engine and allow engine to idle for at least three minutes without turning steering wheel. Turn wheel to left and check for leaks. Add Power Steering Fluid as required.

9. Remove tape and reconnect pitman arm.

**NOTE:** The pitman arm to steering gear nut and washer are important attaching parts in that they could affect the performance of vital components and systems, and/or could result in major repair expense. They must be replaced with the same part numbers or with equivalent parts if replacement becomes necessary. Do not use a replacement part of lesser quality or substitute design. Torque values must be used as specified during reassembly to assure proper retention.

## STEERING GEAR ASSEMBLY

1. Lubricate the worm, lower thrust bearing and the two thrust washers with Power Steering Fluid, then install one thrust washer, the bearing, and the other thrust washer over the end of the worm (figure 47).

2. Lubricate the valve body teflon rings and a new cap to body "O" ring with Power Steering Fluid. Install the cap to body "O" ring in the valve body so it is seated against the lower shaft cap. Align the NARROW NOTCH in the valve body with pin in the worm, then install the valve and shaft assembly in the gear housing (figure 48). Apply pressure to the VALVE BODY when installing. If pressure is ap-

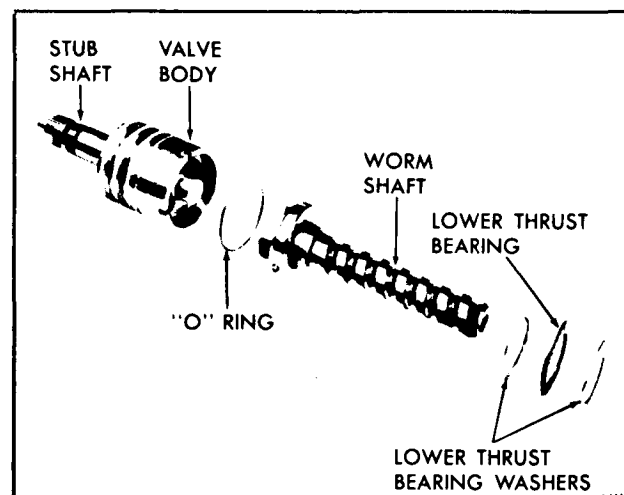

Figure 47—Worm and Valve Body

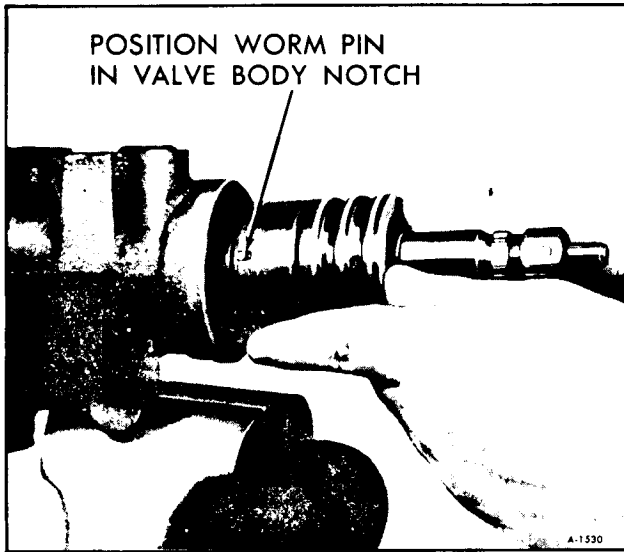

Figure 48-Valve to Worm Alignment

plied to the stub shaft during installation, the shaft may be forced out of the valve body (figure 49).

**NOTE:** The valve body is properly seated when the oil return hole in the housing is entirely uncovered (figure 50).

3. Lubricate a new adjuster plug "O" ring with Power Steering Fluid and install in groove on adjuster plug. Place Seal Protector J-6222 over stub shaft, then install the adjuster plug assembly in the housing until it seats against the valve body (figure 51). Remove Seal Protector.

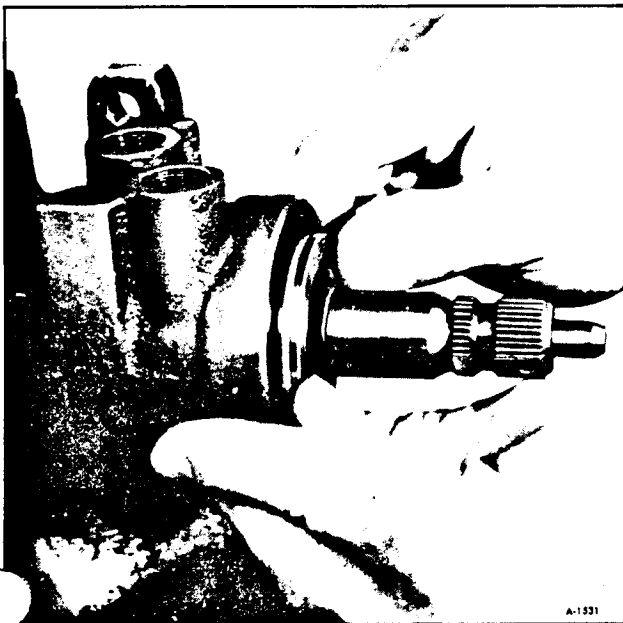

Figure 49-Installing Valve Body

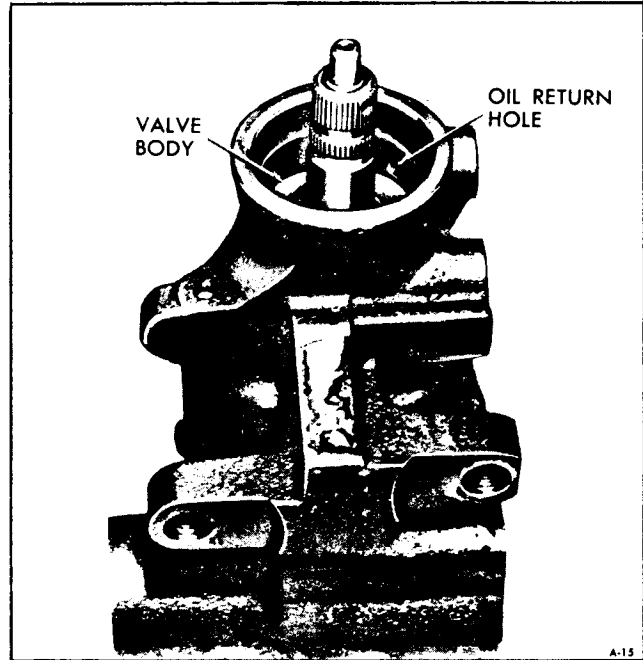

Figure 50-Valve Body in Housing

4. Adjust thrust bearing preload as follows:

a. Using spanner wrench J-7624, 3/4" 12 point socket and in-lb torque wrench tighten adjuster plug up snug (clockwise). Back adjuster plug off 1/4 turn and measure seal drag.

b. Adjust thrust bearing preload to obtain approximately 3-4 in. lbs. in excess of valve assembly drag. Tighten adjuster plug locknut securely while

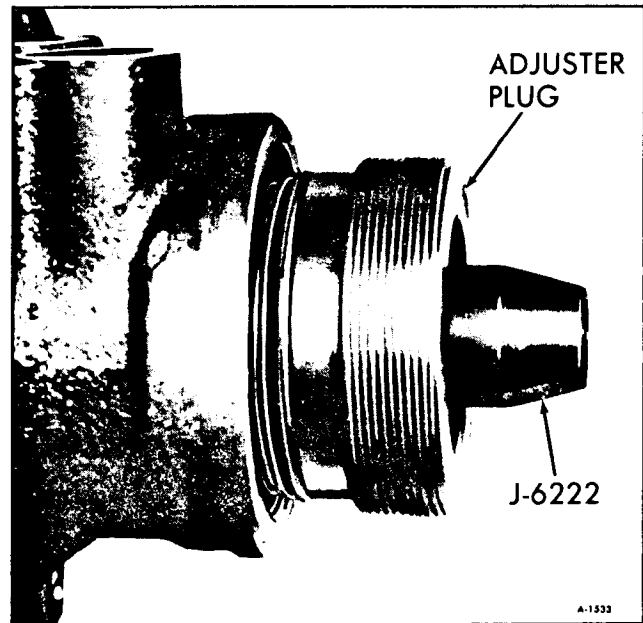

Figure 51-Installing Adjuster Plug

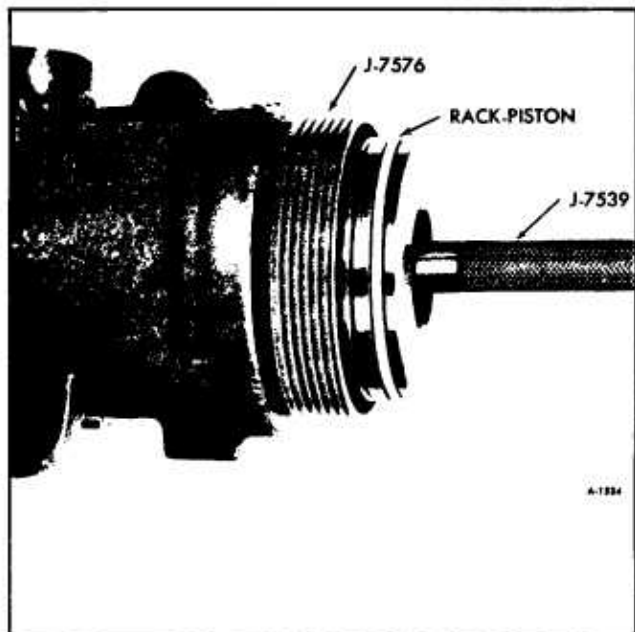

Figure 52—Installing Rack-Piston

holding adjuster plug in position with Tool J-7624. Recheck thrust bearing preload after tightening locknut.

5. Install the rack-piston as follows:

a. Lubricate the rack-piston teflon seal with Power Steering Fluid.

b. Position Seal Compressor J-7576 against the shoulder in the housing.

c. With Ball Retainer J-7539 in place in the rack-piston, push the rack-piston (with teeth toward pitman shaft opening), into the housing until Tool J-7539 contacts the center of worm (figure 52).

d. Turn the stub shaft clockwise with a 3/4" twelve point socket or box end wrench to thread the rack-piston onto the worm while holding Tool J-7539 against the end of the worm.

e. When the rack-piston is completely threaded on the worm, remove Ball Retainer J-7539 and Seal Compressor J-7576.

6. Install the pitman shaft and side cover as follows:

a. Install a new "O" ring in the side cover and retain with heavy grease.

b. Turn the stub shaft until the rack-piston teeth are centered in the pitman shaft opening, then install the pitman shaft and side cover so that the center tooth of the pitman shaft engages the center groove of the rack-piston.

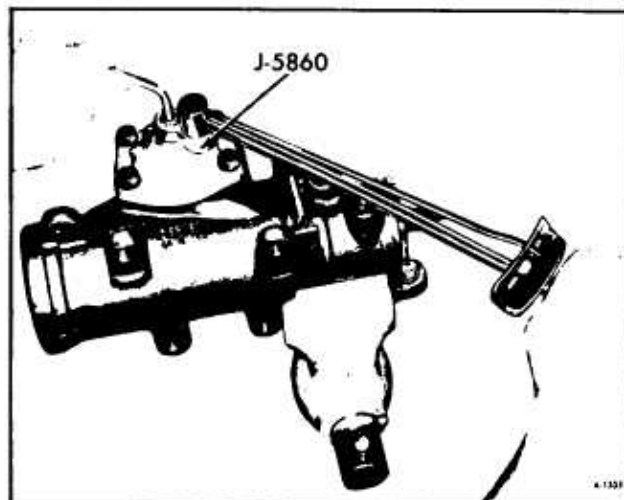

Figure 53—Torquing Over-Center Locknut

c. Install the side cover bolts and tighten to 35 foot pounds.

7. Install the rack-piston plug in the rack-piston and torque to 75 foot pounds.

8. Install a new housing end cover "O" ring and lubricate it with Power Steering Fluid. Install the end cover and retaining ring.

9. Adjust the over-center preload as follows:

a. Make sure the over-center adjusting screw is backed all the way out. Then turned back in 1/2 turn.

b. Install an inch-lb. torque wrench with a 3/4" 12-point socket on the stub shaft splines.

c. Rotate the stub shaft from one stop to the other. Count the number of turns and locate the center of travel, then check the combined ball and thrust bearing preload by rotating the torque wrench through the center of travel. Note the highest reading.

d. Tighten the pitman shaft over-center adjusting screw until the torque wrench reads 3-6 in. lbs. higher than the reading noted in Step c. The total reading should not exceed 14 in. lbs.

3. While holding the adjusting screw, tighten the locknut to 35 foot pounds using Adapter J-5860 (figure 53) and recheck the adjustment.

## STEERING GEAR INSTALLATION

See CAUTION on page 9-1 of this section.

1. Before installing the steering gear, apply a sodium soap fine fiber grease to the gear mounting

ads to prevent squeaks between the gear housing and the frame. Make certain there is a minimum of .040" clearance between coupling yoke and steering gear upper seal.

2. Be sure the steering wheel is properly aligned in relation to the wheels, and tighten the yoke cinch bolt to 30 foot pounds. Tighten the steering gear to frame bolts to 70 foot pounds.

3. Install pitman arm on steering gear, secure with nut torqued to 160-210 foot-pounds.

4. Connect fluid pressure lines and bleed system. (Refer to ADJUSTMENTS under POWER STEERING PUMP earlier in this section).

## STEERING GEAR ADJUSTMENTS

Adjustment of the steering gear in the vehicle is discouraged because of the difficulty encountered in adjusting the worm thrust bearing preload and the confusing effects of the hydraulic fluid in the gear. Since a gear adjustment is made only as a correction and not as a periodic adjustment, it is better to take the extra time and make the adjustment correctly the first time.

Since a handling stability complaint can be caused by improperly adjusted worm thrust bearings as well as an improper gear over-center adjustment, it is necessary that the steering gear assembly be removed from the vehicle and both thrust bearing and over-center preload be checked and corrected as necessary. An in-vehicle check of the steering gear will not pin-point a thrust bearing adjustment error.

### A. Initial Checks

1. Remove gear from vehicle.
2. Drain oil from gear by rotating through its travel several times.
3. Check gear adjustment torque as removed from car as follows:
  - a. One-half turn off right and left stops.
  - b. One-half turn off center-right and left.
  - c. Over center (rotate through an arc 180 degrees each side of center-right and left).

### B. Worm Thrust Bearing Adjustment

1. Loosen pitman shaft lash adjuster screw lock nut.

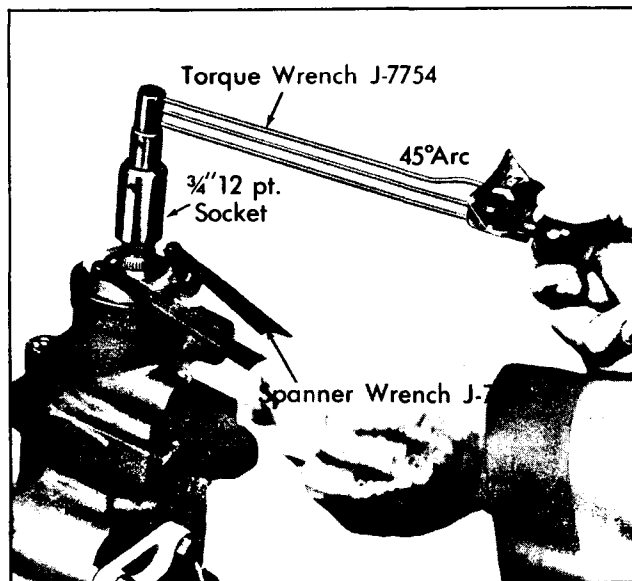

Figure 54-Adjusting Thrust Bearing Preload

2. Back off pitman shaft lash adjuster screw 1-1/2 turns and re-tighten lock nut.
3. Loosen thrust bearing adjuster plug lock nut.
4. Back off thrust bearing adjuster plug 1/4 turn.
5. Turn gear stub shaft to right and then back 1/2 turn.

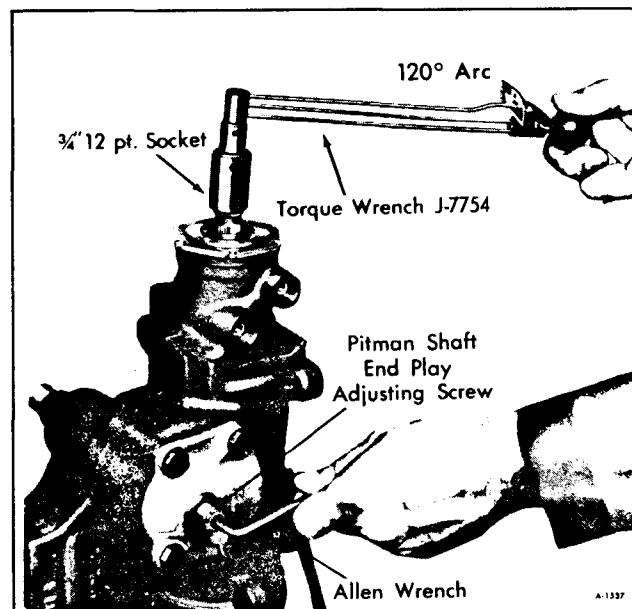

Figure 55-Pitman Shaft Over-Center Adjustment

6. Using an inch pound torque wrench on gear stub shaft, measure drag torque.

7. Tighten adjuster plug until torque to turn stub shaft is 3-4 lb. in greater than drag torque (with lock nut tightened). See Figure 54.

**NOTE:** Preload torque tends to drop off when the lock nut is tightened. Therefore, torque reading must be rechecked with the lock nut tight.

### C. Pitman Shaft Over-Center Adjustment

1. With gear on center, loosen pitman shaft adjuster lock nut and tighten pitman shaft adjuster screw. Retighten lock nut (holding adjuster screw to keep it from turning) and measure gear over-center torque at stub shaft. When checking over-center

torque, torque wrench should be rotated through a 180 degree arc either side of center and readings taken going over-center. Continue adjusting adjuster screw and checking over-center torque (with lock nut tightened) until correct over-center torque is obtained. See Figure 55. Limits for new and old gears are different, as follows:

a. New gear over-center torque to be 4-8 inch-pounds additional torque, but total over-center torque must not exceed 18 inch-pounds.

b. Used gear (400 or more miles). Over-center torque to be 4-5 inch-pounds additional torque, but total over-center must not exceed 14 inch-pounds.

2. Record total over-center torque. This consists of over-center, thrust bearing, and drag torque.

## STEERING COLUMN

**CAUTION:** *All column fasteners are important attaching parts in that they could affect the performance of vital components and systems, and/or could result in major repair expense. They must be replaced with parts of the same part numbers or with equivalent parts if replacement becomes necessary. Do not use replacement parts of lesser quality or substitute design. Torque values must be used as specified during re-assembly to assure proper retention of these parts.*

### GENERAL INFORMATION AND OPERATION

The function locking energy-absorbing steering column includes three important features in addition to the steering function:

I. The column is energy-absorbing, designed to compress up to 8.25 inches in a front-end collision to minimize the possibility of injury to the driver of the vehicle.

II. The ignition switch and lock are mounted conveniently on the column.

III. With the column mounted lock, the ignition, steering and gearshifting operation can be locked to inhibit theft of the vehicle.

The function locking energy-absorbing steering column assembly is used on all vehicles. When a vehicle is being driven, the forward movement of the vehicle and the forward movement of the driver both constitute a form of kinetic energy. When a vehicle

is involved in a frontal collision, the primary force (forward movement of the vehicle) is suddenly halted, while the secondary force (the driver) continues its forward direction. A severe frontal collision generally involves these two forces—the primary and the secondary forces. The secondary impact occurs when the driver is thrust forward onto the steering wheel and column.

The function locking energy-absorbing column is designed to absorb these primary and secondary forces to the extent that the severity of the secondary impact is reduced.

The tilt function locking columns are designed for ease of entry and driver comfort. These columns have six or seven different steering wheel angle positions.

The tilt mechanism consists of an upper and lower steering shaft assembly with a universal joint between them. A support assembly is held to the mast jacket by a lock plate, and a bearing housing assembly is positioned over the upper steering shaft and secured to the support by two pivot pins. Two

lock shoes are pinned to the housing assembly and engage a pin in the support assembly. When the release lever is pulled up and the lock shoes disengage the support pin, the steering wheel is pushed up by a spring compressed between the support and housing assemblies.

The operation of the lock is the same as in other GM vehicles. To start the vehicle, you insert the key in the lock, turn the unit clockwise to "start" and let the switch return to the "on" position. The "off", "lock" and "accessory" positions are also the same as in other GM vehicles. When you engage the shift lever in "park" and lock the ignition, the steering wheel locks and the gearshift locks.

The function locking energy-absorbing column may be easily disassembled and reassembled. The serviceman should be aware that it is important that only the specified screws, bolts and nuts be used as designated and that they are tightened to their specified torque. This precaution will insure the energy

absorbing action of the assembly. Overlength bolts should not be used, as they may prevent a portion of the assembly from compressing under impact. Equally as important is correct torque of bolts and nuts. Care should be taken to assure that the bolts or nuts securing the column mounting bracket to the instrument panel are torqued to the proper specification in order that the bracket will break away under impact.

When the column is removed, special care must be taken in handling this assembly. Only the specified wheel puller should be used. When the column is removed from the vehicle, such actions as a sharp blow on the end of the steering shaft or shift lever, leaning on the column assembly, or dropping of the assembly could shear or loosen the plastic fasteners that maintain column rigidity. It is, therefore, important that the removal and installation and the disassembly and reassembly procedures be carefully followed when servicing the assembly.

## STEERING COLUMN TROUBLE DIAGNOSIS

### (STANDARD AND TILT STEERING COLUMNS)

#### LOCK SYSTEM DIAGNOSIS

Condition	Possible Cause	Correction
Will not unlock.	<ul style="list-style-type: none"> <li>A. Shear flange on sector shaft collapsed.</li> <li>B. Lock bolt damaged.</li> <li>C. Defective lock cylinder.</li> <li>D. Damaged housing.</li> <li>E. Damaged sector.</li> <li>F. Damaged rack.</li> </ul>	<ul style="list-style-type: none"> <li>A. Replace sector.</li> <li>B. Replace lock bolt.</li> <li>C. Replace lock cylinder.</li> <li>D. Replace housing.</li> <li>E. Replace sector.</li> <li>F. Replace rack.</li> </ul>
Will not lock.	<ul style="list-style-type: none"> <li>A. Lock bolt spring broken or defective.</li> <li>B. Damaged sector tooth.</li> <li>C. Defective lock cylinder.</li> <li>D. Burr on lock bolt or housing.</li> <li>E. Damaged housing.</li> <li>F. Transmission linkage adjustment incorrect.</li> <li>G. Damaged rack.</li> <li>H. Interference between bowl and rack coupling.</li> <li>I. Ignition switch stuck.</li> <li>J. Acutator rod restricted.</li> </ul>	<ul style="list-style-type: none"> <li>A. Replace lock bolt spring.</li> <li>B. Replace sector.</li> <li>C. Replace lock cylinder.</li> <li>D. Remove burr.</li> <li>E. Replace housing.</li> <li>F. Readjust.</li> <li>G. Replace rack.</li> <li>H. Replace bowl or actuator rod as required.</li> <li>I. Replace ignition switch.</li> <li>J. Readjust.</li> </ul>



## STEERING COLUMN TROUBLE DIAGNOSIS (Cont'd.)

Condition	Possible Cause	Correction
High effort.	A. Lock cylinder defective. B. Ignition switch defective. C. Rack preload spring broken or deformed. D. Burrs on sector, rack, housing, support or actuator rod coupling. E. Bent sector shaft. F. Defective rack. G. Extreme misalignment of housing to cover. H. Distorted coupling slot in rack. I. Bent actuator rod. J. Ignition switch mounting bracket bent.	A. Replace lock cylinder. B. Replace ignition switch. C. Replace preload spring. D. Remove burr. E. Replace shaft. F. Replace rack. G. Replace either or both. H. Replace rack. I. Straighten or replace. J. Straighten or replace.
Will stick in "start".	A. Actuator rod deformed. B. Any high effort condition.	A. Straighten or replace. B. Check items under high effort section.
Key can not be removed in "off-lock".	A. Ignition switch is not set correctly. B. Defective lock cylinder.	A. Readjust. B. Replace lock cylinder.
Lock cylinder can be removed without depressing retainer.	A. Lock cylinder with defective retainer. B. Lock cylinder without retainer. C. Burr over retainer slot in housing cover.	A. Replace lock cylinder. B. Replace lock cylinder. C. Remove burr.

## IGNITION SYSTEM DIAGNOSIS

Condition	Possible Cause	Correction
Electrical system will not function.	A. Poor battery connection. B. Connector body loose or defective. C. Defective wiring. D. Defective ignition switch. E. Ignition switch not adjusted properly.	A. Connect securely. B. Tighten or replace. C. Repair or replace. D. Replace ignition switch. E. Readjust.
Switch will not actuate mechanically.	A. Defective ignition switch.	A. Replace.

## STEERING COLUMN TROUBLE DIAGNOSIS (Cont'd.)

Condition	Possible Cause	Correction
Switch can not be set correctly.	<p>A. Switch actuator rod deformed.</p> <p>B. Sector to rack en- in wrong tooth.</p>	<p>A. Repair or replace.</p> <p>B. Engage correctly.</p>

## STEERING COLUMN

Condition	Possible Cause	Correction
Noise in column.	<p>A. Coupling bolts not tightened.</p> <p>B. Column not correctly aligned.</p> <p>C. Coupling pulled apart.</p> <p>D. Broken lower joint.</p> <p>E. Horn contact ring not lubricated.</p> <p>F. Lack of grease on bearings or bearing surfaces.</p> <p>G. Loose sight shields.</p> <p>H. Lower shaft bearing worn or broken.</p> <p>I. Upper shaft bearing worn or broken.</p> <p>J. Shaft lock plate cover loose.</p> <p>K. Shaft lock snap ring not seated.</p> <p>L. One click when in "off-lock" position and the steering wheel is moved.</p>	<p>A. Tighten pinch bolts to 30 foot pounds.</p> <p>B. Realign column.</p> <p>C. Realign column and replace coupling.</p> <p>D. Repair joint using kit #7810077 and realign column.</p> <p>E. Lubricate with lubriplate.</p> <p>F. Lubricate.</p> <p>G. Bend to eliminate rattle.</p> <p>H. Replace bearing. Check shaft and replace if scored.</p> <p>I. Replace bearing assembly.</p> <p>J. Tighten three screws to 15 in.-lbs., or if missing, replace. <b>Caution:</b> Use specified screws.</p> <p>K. Replace snap ring. Check for proper seating in groove.</p> <p>L. Normal-lock bolt is seating.</p>
High steering shaft effort.	<p>A. Column assembly mis-aligned.</p> <p>B. Improperly installed or deformed dust seal.</p> <p>C. Defective upper or lower bearing.</p> <p>D. Flash on I.D. of shift tube from plastic joint.</p> <p>E. Tight steering uni- versal joint.</p>	<p>A. Realign.</p> <p>B. Install new seal.</p> <p>C. Replace.</p> <p>D. Replace shift tube.</p> <p>E. Repair or replace.</p>
High shift effort.	<p>A. Column not aligned correctly in vehicle.</p>	<p>A. Realign.</p>

## STEERING COLUMN TROUBLE DIAGNOSIS (Cont'd.)

Condition	Possible Cause	Correction
	B. Wave washer with burrs. C. Improperly installed dust seal. D. Lack of grease on seal or bearing. E. Improper screws used for ignition switch, neutral start switch or mounting bracket. F. Burr on upper or lower end of shift tube.	B. Replace. C. Remove and replace.  D. Lubricate.  E. Use correct fasteners.  F. Remove burr.
Improper transmission shifting.	A. Sheared shift tube joint or lower shift lever weld. B. Improper transmission linkage adjustment.	A. Replace tube assembly.  B. Readjust.
Miscellaneous.	A. Housing loose on jacket—will be noticed with ignition in “off-lock” and a torque applied to the steering wheel.	A. Tighten four mounting screws 60 in.-lbs.
Lash in mounted column assembly.	A. IP to column bracket mounting bolts loose. B. Broken weld nuts on jacket. C. IP bracket capsule sheared. D. Loose shoes in housing. E. Loose tilt head pivot pins. F. Loose shoe lock pin in support. G. Loose support screws. H. Column bracket to jacket bolts loose.	A. Tighten to 20 foot pounds. B. Replace jacket assembly. C. Replace bracket assembly. D. Replace shoes. E. Replace pivot pins. F. Replace pin. G. Tighten to 60 in.-lbs. H. Tighten to 15 foot pounds.
Housing scraping on bowl.	A. Bowl bent or not concentric with hub.	A. Replace bowl.
Steering wheel loose.	A. Excessive clearance between holes in support or housing and pivot pin diameters. B. Defective or missing anti-lash spring in spheres. C. Upper bearing not seating in bearing. D. Upper bearing inner race seat missing.	A. Replace either or both.  B. Add spring or replace both.  C. Replace both.  D. Install seat.

## STEERING COLUMN TROUBLE DIAGNOSIS (Cont'd.)

Condition	Possible Cause	Correction
	<p>E. Improperly adjusted tilt locking knob.</p> <p>F. Loose support screws.</p> <p>G. Bearing preload spring missing or broken.</p>	<p>E. Readjust.</p> <p>F. Tighten 60 in.-lbs.</p> <p>G. Replace preload spring.</p>
Steering wheel loose—every other tilt position.	A. Loose fit between shoe and shoe pivot pin.	A. Replace both.
Steering column not locking in any tilt position.	<p>A. Shoe seized on its pivot pin.</p> <p>B. Shoe grooves may have burrs or dirt.</p> <p>C. Shoe lock spring weak or broken.</p>	<p>A. Replace both.</p> <p>B. Replace shoe.</p> <p>C. Replace lock spring.</p>
Steering wheel fails to return to top tilt position.	<p>A. Pivot pins are bound up.</p> <p>B. Wheel tilt spring is defective.</p> <p>C. Turn signal switch wires too tight.</p>	<p>A. Replace pivot pins.</p> <p>B. Replace tilt spring.</p> <p>C. Readjust.</p>
Noise when tilting column.	<p>A. Upper tilt bumpers worn.</p> <p>B. Tilt spring rubbing in housing.</p>	<p>A. Replace tilt bumper.</p> <p>B. Lubricate.</p>

## SIGNAL SWITCH DIAGNOSIS

Condition	Possible Cause	Correction
Turn signal will not cancel.	<p>A. Loose switch mounting screws.</p> <p>B. Switch or anchor bosses broken.</p> <p>C. Broken, missing or out of position detent, return or cancelling spring.</p> <p>D. Uneven or incorrect cancelling cam to cancelling spring interference. (.120)/side.</p>	<p>A. Tighten to specified torque (25 in.-lbs.).</p> <p>B. Replace switch.</p> <p>C. Reposition or replace springs as required.</p> <p>D. Adjust switch position.           <ol style="list-style-type: none"> <li>1. If interference is correct and switch will still not cancel, replace switch.</li> <li>2. If interference cannot be corrected by switch adjustment, replace cancelling cam.</li> </ol> </p>

## STEERING COLUMN TROUBLE DIAGNOSIS (Cont'd.)

Condition	Possible Cause	Correction
Turn signal difficult to operate.	A. Actuator rod loose. B. Yoke broken or distorted. C. Loose or misplaced D. Foreign parts and/or materials. E. Switch mounted loosely.	A. Tighten mounting screw (12 in.-lb.). B. Replace switch. C. Reposition or replace springs. D. Remove foreign parts and/or material. E. Tighten mounting screws (25 in.-lbs.).
Turn signal will not indicate lane change.	A. Broken lane change pressure pad or spring hanger. B. Broken, missing or misplaced lane change spring. C. Jammed base or wires.	A. Replace switch. B. Replace or reposition as required. C. Loosen mounting screws, reposition base or wires and retighten screws (25 in.-lbs.).
Turn signal will not stay in turn position.	A. Foreign material or loose parts impeding movement of yoke. B. Broken or missing detent or cancelling springs. C. None of the above.	A. Remove material and/or parts. B. Replace spring. C. Replace switch.
Hazard switch cannot be turned off.	A. Foreign material between hazard support cancelling leg and yoke.	A. Remove foreign material. 1. No foreign material impeding function of hazard switch—replace turn signal switch.
Hazard switch will not stay on or difficult to turn off.	A. Loose switch mounting screws. B. Interference with other components. C. Foreign material. D. None of the above.	A. Tighten mounting screws (25 in.-lbs.). B. Remove interference. C. Remove foreign material. D. Replace switch.
No turn signal lights.	A. Defective or blown fuse. B. Inoperative turn signal flasher. C. Loose chassis to column connector. D. *Disconnect column to chassis connector. Connect new switch to chassis and operate switch by hand. If vehicle lights now operate normally, signal switch is inoperative. E. If vehicle lights do not operate check chassis wiring for opens, grounds, etc.	A. Replace fuse. B. Replace turn signal flasher. C. Connect securely. D. Replace signal switch. E. Repair chassis wiring as required using manual as guide.

## STEERING COLUMN TROUBLE DIAGNOSIS (Cont'd.)

Condition	Possible Cause	Correction
Turn indicator lights on, but not flashing.	<p>A. Inoperative turn flasher.</p> <p>B. Loose chassis to column connection.</p> <p>C. Inoperative turn signal switch.</p> <p>D. To determine if turn signal switch is defective, substitute new switch into circuit and operate switch by hand. If the vehicle's lights operate normally, signal switch is inoperative.</p> <p>E. If the vehicle's lights do not operate, check light sockets for high resistance connections, the chassis wiring for opens, grounds, etc.</p>	<p>A. Replace turn flasher. Note: There are two flashers in the system. Consult manual for location.</p> <p>B. Connect securely.</p> <p>C. Replace turn signal switch.</p> <p>D. Replace signal switch.</p> <p>E. Repair chassis wiring as required using manual as guide.</p>
Front or rear turn signal lights not flashing.	<p>A. Burned out or damaged turn signal bulb.</p> <p>B. High resistance connection to ground at bulb socket.</p> <p>C. Loose chassis to column connector.</p> <p>D. Disconnect column to chassis connector. Connect new switch into system and operate switch by hand. If turn signal lights are now on and flash, turn signal switch is inoperative.</p> <p>E. If vehicle lights do not operate, check chassis wiring harness to light sockets for opens, grounds, etc.</p>	<p>A. Replace bulb.</p> <p>B. Remove or repair defective connection.</p> <p>C. Connect securely.</p> <p>D. Replace turn signal switch.</p> <p>E. Repair chassis wiring as required using manual as guide.</p>
Stop light not on when turn indicated	<p>A. Loose column to chassis connection.</p> <p>B. Disconnect column to chassis connector. Connect new switch into system without removing old. Operate switch by hand. If brake lights work with switch in the turn position, signal switch is defective.</p>	<p>A. Connect securely.</p> <p>B. Replace signal switch.</p>

## STEERING COLUMN TROUBLE DIAGNOSIS (Cont'd.)

Condition	Possible Cause	Correction
	<p>C. If brake lights do not work check connector to stop light sockets for grounds, opens, etc.</p>	<p>C. Repair connector to stop light circuits using manual as guide.</p>
<p>Turn indicator panel lights not flashing.</p>	<p>A. Burned out bulbs.            B. High resistance to ground at bulb socket.            C. Opens, grounds in wiring harness from front turn signal bulb socket to indicator lights.</p>	<p>A. Replace bulbs.            B. Replace socket.            C. Locate and repair as required. Use shop manual as guide.</p>
<p>Turn signal lights flash very slowly.</p>	<p>A. Inoperative turn signal flasher.            B. System charging voltage low.            C. High resistance ground at light sockets.            D. Loose chassis to column connection.            E. Disconnect column to chassis connector. Connect new switch into system without removing old. Operate switch by hand. If flashing occurs at normal rate, the signal switch is defective.            F. If the flashing rate still extremely slow, check chassis wiring harness from the connector to light sockets for grounds, high resistance points, etc.</p>	<p>A. Replace turn signal flasher.            B. Increase voltage to specified. Use manual.            C. Repair high resistance grounds at light sockets.            D. Connect securely.            E. Replace signal switch.            F. Locate and repair as required. Use manual as guide.</p>
<p>Hazard signal lights will not flash—turn signal functions normally.</p>	<p>A. Blown fuse.            B. Inoperative hazard warning flasher.            C. Loose chassis to column connection.            D. Disconnect column to chassis connector. Connect new switch into system without removing old. Depress the hazard warning button and observe the hazard warning lights. If they now work normally, the turn signal switch is defective.</p>	<p>A. Replace fuse.            B. Replace hazard warning flasher.            C. Connect securely.            D. Replace the turn signal switch.</p>

## STEERING COLUMN TROUBLE DIAGNOSIS (Cont'd.)

Condition	Possible Cause	Correction
	E. If the lights do not flash, check wiring harness "K" lead (brown) for open between hazard flasher and harmonica connector. If open, fuse block is defective.	E. Replace fuse block.

## KEY BUZZER DIAGNOSIS

Condition	Possible Cause	Correction
Buzzer does not sound with key fully inserted in lock cylinder with the entrance door open.	<p>A. Defective buzzer.</p> <p>B. Bad connection at buzzer.</p> <p>C. Power not available to buzzer.</p> <p>D. Door jamb switch misadjusted or in-operative.</p> <p>E. Short in chassis wiring.</p>	<p>A. Replace buzzer.</p> <p>B. Connect securely.</p> <p>C. Check continuity of chassis wiring and repair as required.</p> <p>D. Readjust or replace—as required.</p> <p>E. Check by separating chassis to column connector. Connect "E" (black) and "F" (black w/pink stripe) female contacts on the chassis side (figure 56). Bent paper clip will work if buzzer sounds, continue diagnosis. If not, locate, and repair chassis wiring, use manual as guide.</p>

**NOTE 1:** If the buzzer fault has not yet been detected, connect a continuity meter (light) to the male "E" and "F" connector contacts (figure 57). Insert the key the full depth into the lock cylinder.

If contact is made with the key in, and is not made with it out, the function is normal. Retrace initial diagnostic steps.

If contact is not established, the fault is in the column. Proceed to Note 2.

**NOTE 2:** With the fault isolated in the column, disassemble the upper end of the column until the signal switch mounting screws have been removed. Lift the switch and check the probes of the buzzer switch to insure good contact with the pads on the signal switch. Bend probes, if required, then reseal the signal switch and drive the three screws. Check the function, as in Note 1.



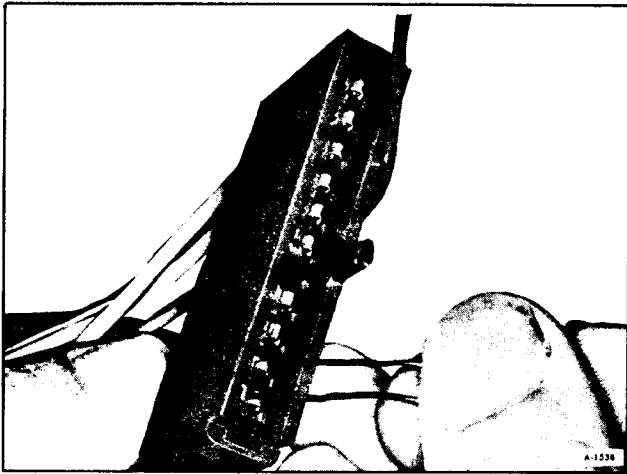

Figure 56—Checking For Short In Chassis Wiring

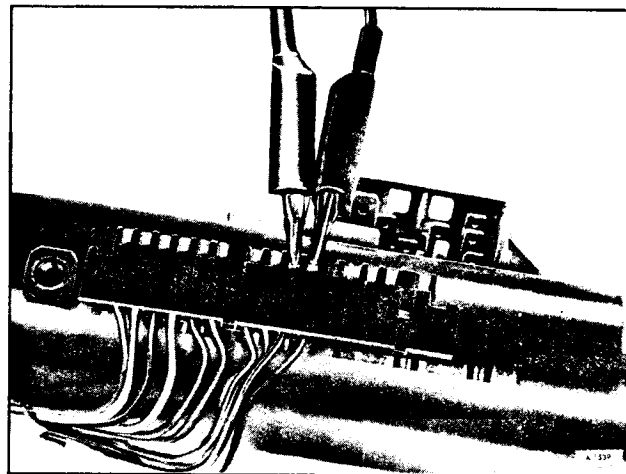

Figure 57—Checking Column Buzzer Circuit Continuity

### STEERING COLUMN TROUBLE DIAGNOSIS (Cont'd.)

Condition	Possible Cause	Correction
Buzzer does not sound with key fully inserted in lock cylinder with the entrance door open.	F. Short or fault in signal switch wiring.	F. Connect male "E" and "F" contacts of connector with jumper (figure 58). Check buzzer switch pads with continuity meter. If contact is made, function is normal. If not, replace signal switch.

**NOTE 3:** If the fault has not yet been isolated and repaired, connect a continuity meter to the buzzer switch probes (figure 59). Fully insert and remove the key from the lock cylinder.

If contact is made with the key in, and is broken with it out, the function is normal. Retrace diagnostic steps starting at Note 2.

If contact is not made, the fault is in the lock cylinder or buzzer switch.

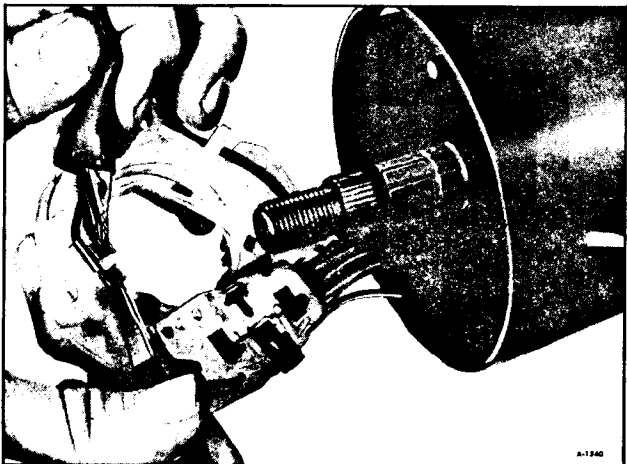

Figure 58—Checking Buzzer Switch Pads

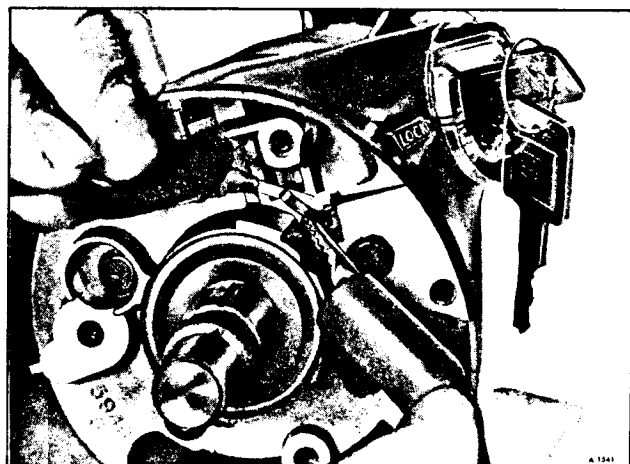

Figure 59—Checking Buzzer Switch Continuity

## STEERING COLUMN TROUBLE DIAGNOSIS (Cont'd.)

Condition	Possible Cause	Correction
<p>Buzzer does not sound with the key fully inserted in lock cylinder with the entrance door open.</p>	<p>G. Chips, burrs, foreign material preventing actuator tip function.  <b>Caution:</b> Key must be removed or cylinder in "run" position before removing lock cylinder.            H. Defective lock</p> <p>I. Chips, foreign material affecting buzzer switch operation.            J. Damaged or broken buzzer switch.            K. Switch appears good but will not make buzzer switch function check.</p> <p>L. Buzzer switch contact gap too large.</p>	<p>G. Remove chips, burrs, etc. Reassemble and re-check ref. note 3.</p> <p>H. With the lock cylinder out (observing caution under G), fully insert and remove the key. The actuator (figure 60 and 61) should extend and retract smoothly. Total extension of tip should be .050 in. If not, replace lock cylinder.            I. Remove and clean as required—reassemble and re-check per note 3.</p> <p>J. Replace buzzer switch.</p> <p>K. Connect continuity meter leads to the buzzer switch probes. Press on the actuator pad until the interior points contact. (figure 62). If contact is not made, replace buzzer switch.            L. Reset contact gap.</p>

**NOTE 4: Setting the contact gap.** Press a .030 wire type spark plug gap wire with flat piece of stock on the actuator pad. (figure 63) If contact is not made adjust switch as shown in Figure 64, until positive contact is made. (Use continuity meter).

With positive contact at .030, use a .025 plug gap wire beneath the flat stock (figure 65). No contact should occur. Adjust as shown in Figure 66. When the switch will make contact with the .030 wire and not with the .025, the buzzer switch is set at the low limit.

Condition	Possible Cause	Correction
<p>Buzzer continues to operate with key in the lock cylinder with the entrance door either opened or closed and ceases when key is removed.</p>	<p>A. Door jamb switch misadjusted or inoperative or inoperative.</p> <p>B. Wire from signal switch to door jamb switch shorted.</p>	<p>A. Adjust or replace as required.</p> <p>B. If on signal switch side, replace signal switch. If on chassis side, find and repair—use manual.</p>

**NOTE5:** This condition indicates the lock cylinder or buzzer switch is at fault. To verify, check for continuity at the "E" "F" male connector contacts with the key removed from the cylinder (figure 57). If continuity exists, the fault is in the column.

## STEERING COLUMN TROUBLE DIAGNOSIS (Cont'd.)

Condition	Possible Cause	Correction
Buzzer continues to operate with key out, but stops when door is closed.	<p>A. Turn lock towards "start" position if buzzer stops in "run" position or when turned past "run" towards "start", the problem is a sticky lock cylinder actuator.</p> <p>B. Chips, foreign material in lock cylinder bore.</p> <p>C. Sticky lock cylinder actuator tip.</p> <p>D. Damaged or broken buzzer switch.</p> <p>E. Buzzer switch contact gap too close.</p>	<p>A. Replace lock cylinder.</p> <p>B. Remove, reassemble and recheck function.</p> <p>C. Replace lock cylinder.</p> <p>D. Replace buzzer switch.</p> <p>E. Adjust as specified.</p>

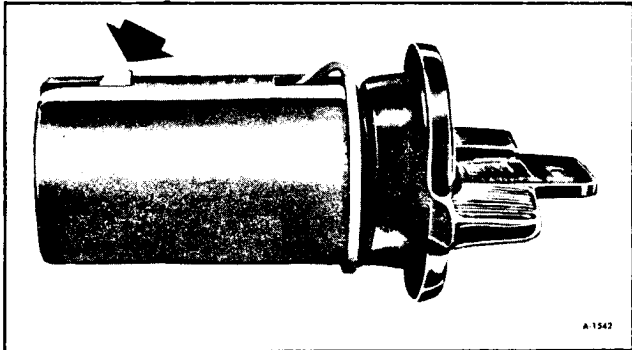

Figure 60-Actuator Extended

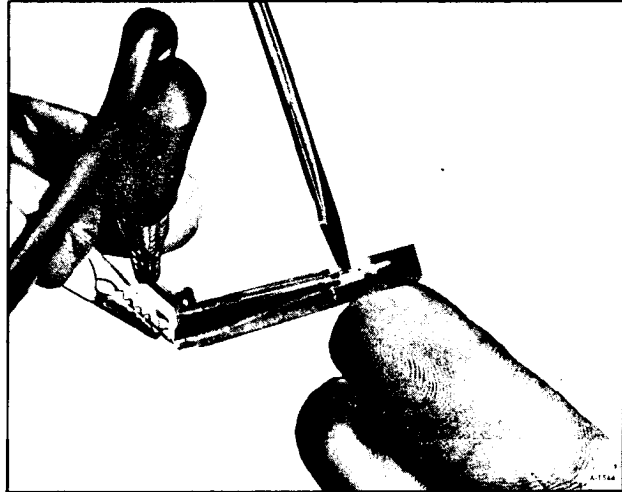

Figure 62-Checking Buzzer Switch Continuity

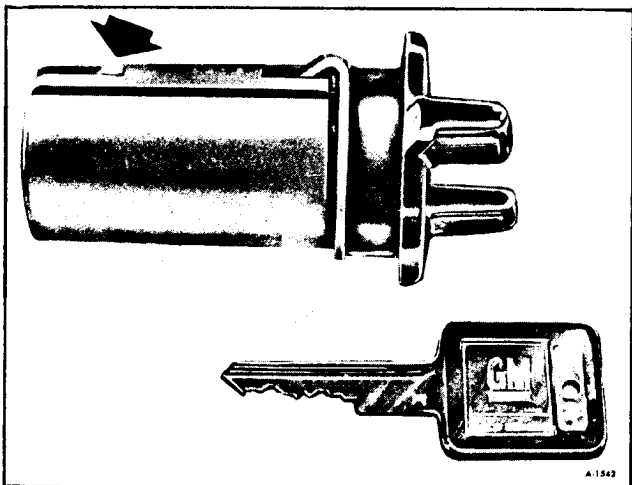

Figure 61-Acutator Retracted

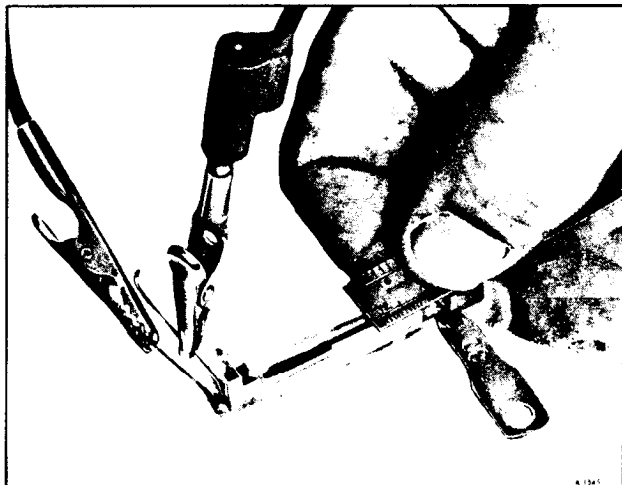

Figure 63-Checking Contact Gap



Figure 64—Adjusting Buzzer Switch

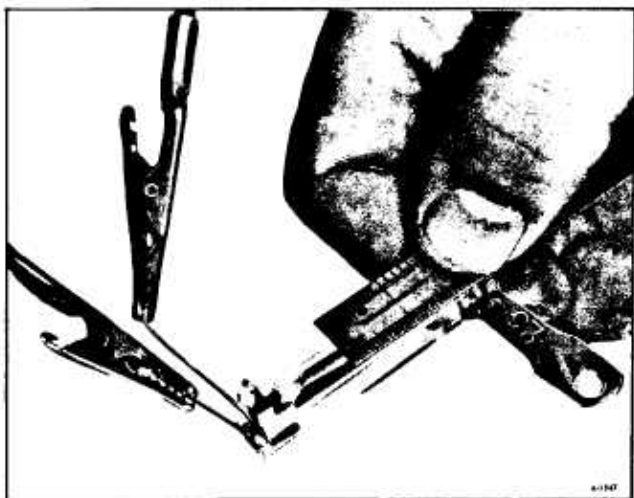

Figure 65—Checking Contact Gap

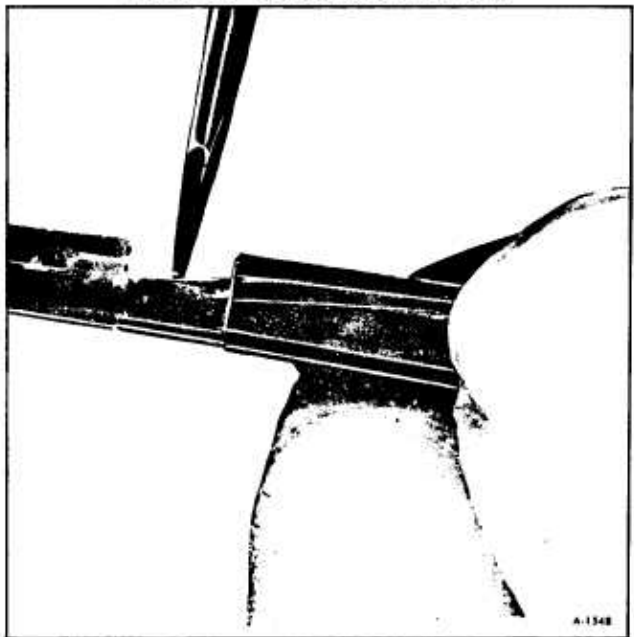

Figure 66—Adjusting Buzzer Switch

## REMOVAL OF STEERING COLUMN

### (Standard and Tilt)

**NOTE:** Once the steering column is removed from the vehicle, the column is extremely susceptible to damage. Dropping the column assembly on its end could collapse the steering shaft or loosen the plastic injections which maintain column rigidity. Leaning on the column assembly could cause the jacket to bend or deform. Any of the above damage could impair the column's collapsible design. If it is necessary to remove the steering wheel, use standard wheel puller. Under no conditions should the end of the shaft be hammered upon as hammering could loosen plastic injections which maintain column rigidity.

1. Disconnect column from lower steering shaft at cinch clamp.
2. Disconnect the shift linkage from the shift lever.
3. Remove screws securing toe pan cover to firewall and loosen cover.
4. Remove bolts securing bracket to instrument panel and disconnect "PARK RNDSL" pointer on the automatic shift column.
5. Disconnect all electrical connectors from the steering column assembly. Carefully withdraw column.

## STANDARD COLUMN OVERHAUL (FIGURE 67)

**NOTE:** All elements of energy-absorbing columns are sensitive to damage and must be handled with care.

### DISASSEMBLY—UPPER END

Steps "1" through "12" can be performed in or out of the vehicle.

**IMPORTANT:** Make sure column is not bent during removal from vehicle.

1. Remove steering wheel using standard wheel puller. **DO NOT HAMMER ON END OF STEERING SHAFT.**

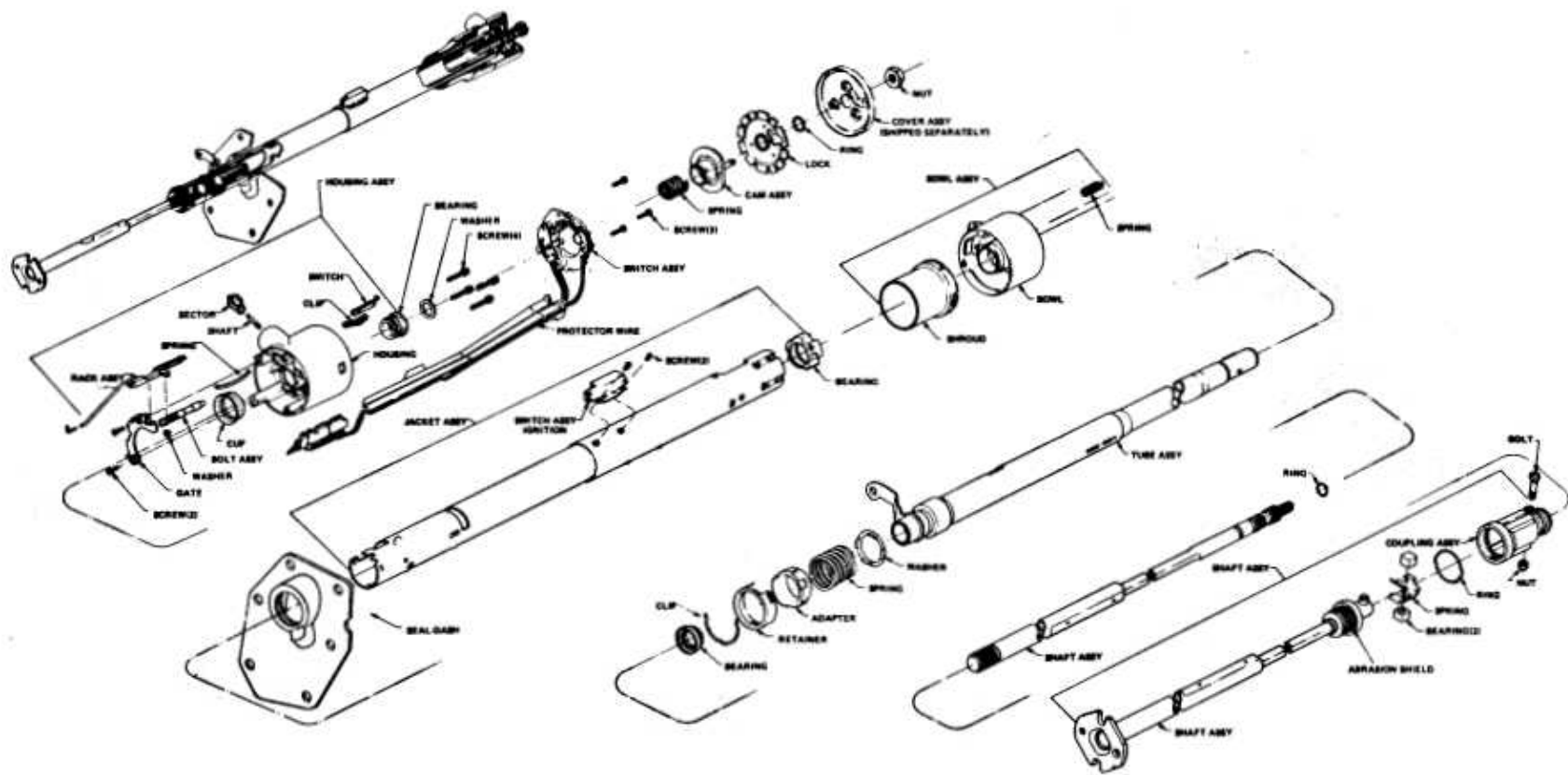

A-1549

Figure 67-Standard Column

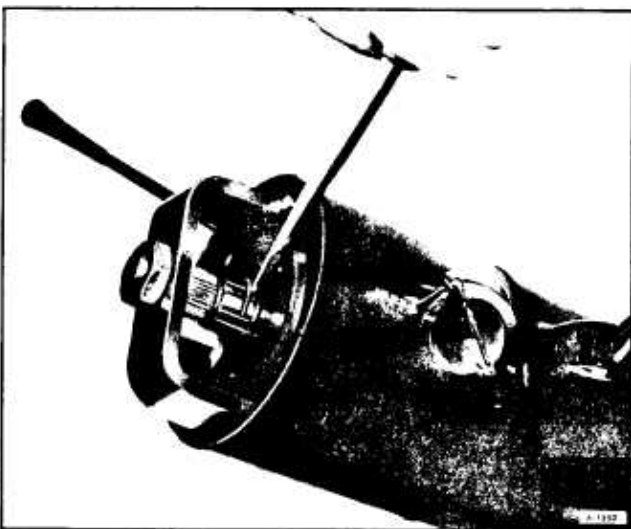

Figure 68—Removing Retaining Ring

2. Remove the three cover screws and lift cover off the shaft.

3. Depress lock plate downward as far as possible using special tool J-23131 or J-23653 and the hand wheel nut. Pry the retaining ring out of the shaft groove. (figure 68). Remove the retaining ring and lock plate. (figure 69).

**CAUTION:** *With ring removed, shaft could slide out bottom of column causing damage to shaft.*

4. Slide upper bearing preload spring and turn signal cancelling cam off upper steering shaft.



Figure 69—Removing Lock Plate

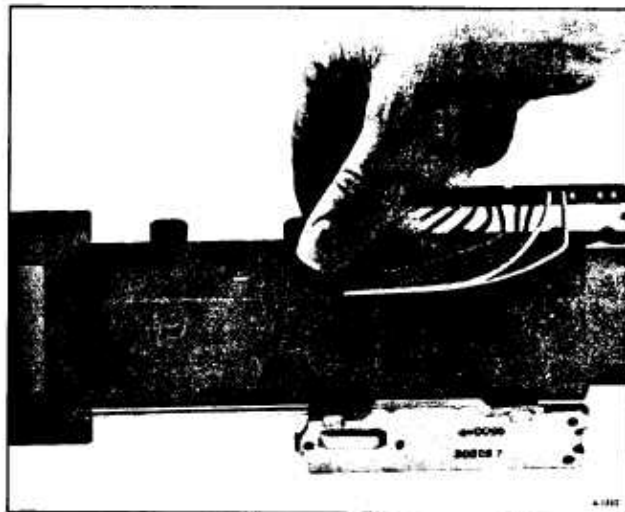

Figure 70—Removing Protector

5. Slide thrust washer off upper steering shaft.

6. Remove turn signal lever screw and lever.

7. Push hazard warning switch in and unscrew knob.

8. Remove three switch mounting screws. Remove the four mounting bracket screws and the bracket from the jacket. Pull the connector out of the bracket on the jacket. Remove the protector from the jacket and strip the wires from it. (figure 70).

9. Pull the switch straight up, being careful not to snag the signal switch wire connector in the housing. (figure 71).

10. The lock cylinder should be removed in the "run" position.

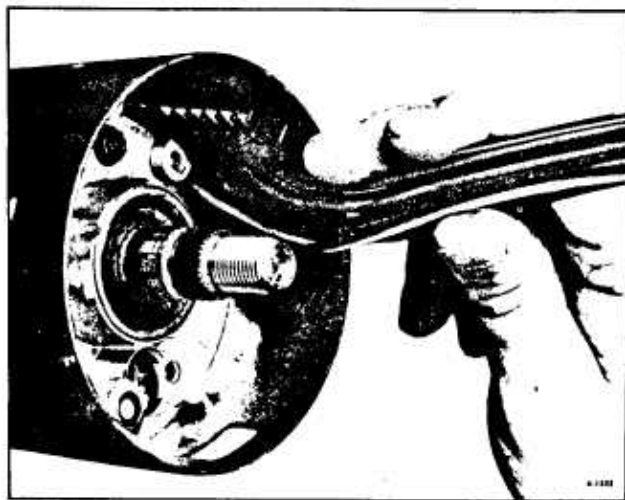

Figure 71—Removing Switch Assembly

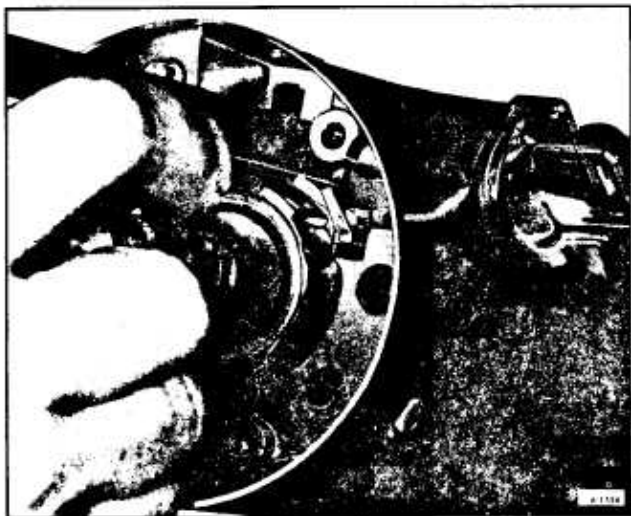

Figure 72—Removing Lock

11. Insert a thin tool (small screw driver or knife blade) into the slot next to the switch mounting screw boss (right-hand slot) and depress retainer at bottom of slot, which releases lock. Remove lock. (figure 72).

12. The buzzer switch can be pulled straight out of the housing. A flat spring wedges the switch toward the lock cylinder. (This may be done without the removal of the lock cylinder. If the lock cylinder is in the housing, it must be in the "run" position.) (figure 73).

If service is required on the upper end only, steps 1 through 12 can be performed in the vehicle.

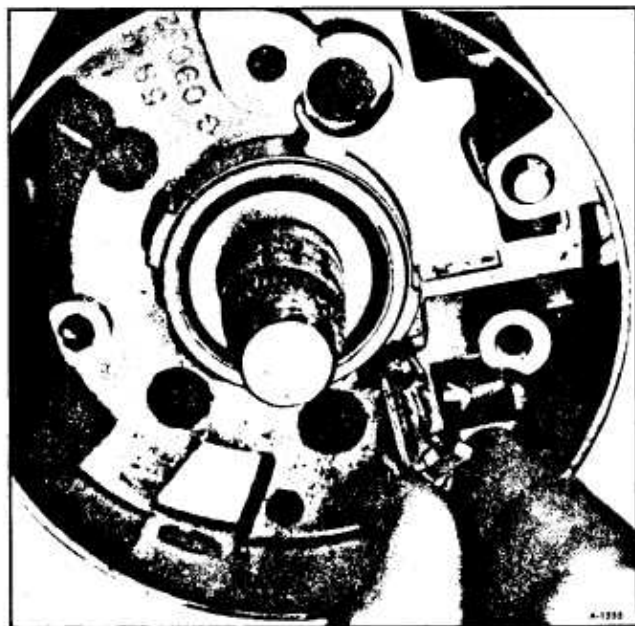

Figure 73—Removing Buzzer Switch

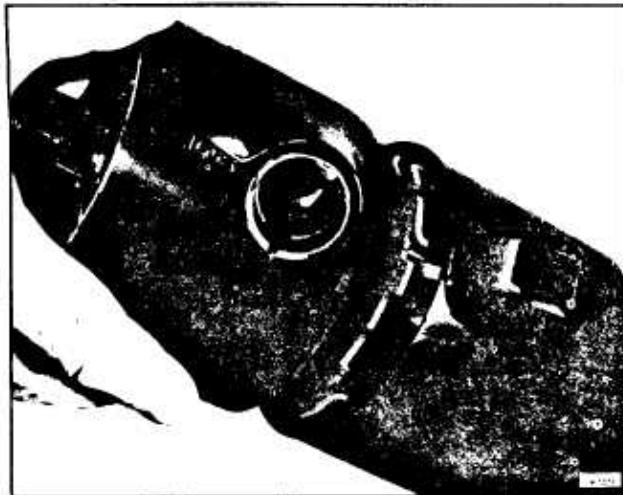

Figure 74—Removing Upper Housing Assembly

13. To remove any further parts from the upper end, the ignition switch should be removed. The switch should be positioned in "off-unlocked" position before removing. If the lock cylinder has already been removed, the connecting rods to the switch should be pulled up to a definite stop and then moved down two detents, which is the "off-unlocked" position. Now remove the two attaching screws and the switch.

14. Drive out shift lever pivot pin and remove shift lever.

15. Remove the four screws attaching the upper housing to the jacket. Remove the upper housing assembly. (figure 74).

16. Remove thrust cup. (figure 75).

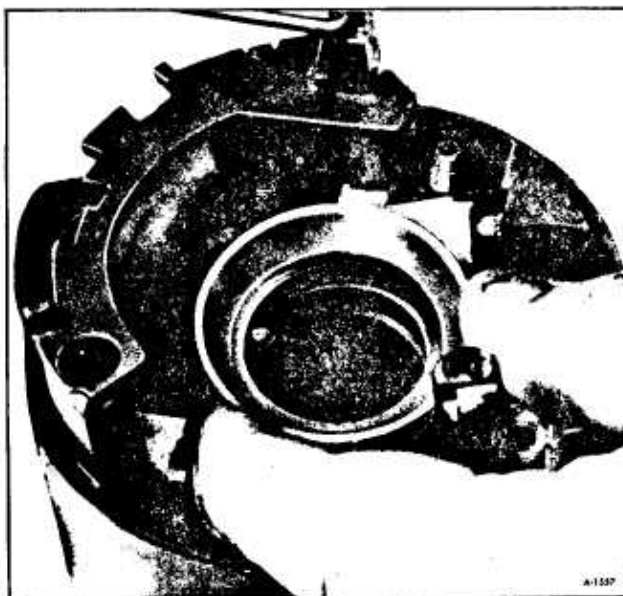

Figure 75—Removing Thrust Cup



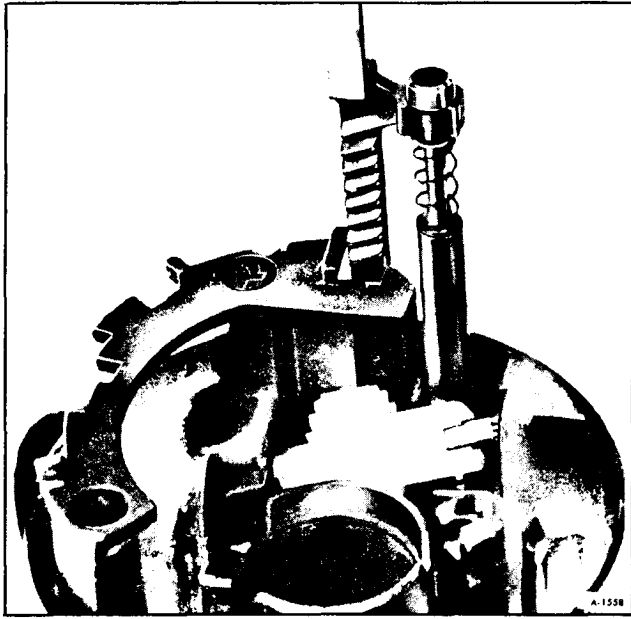

Figure 76-Removing Rack and Lock Bolt

17. Remove the rack and lock bolt. (figure 76).

18. Remove rack preload spring. (figure 77).

19. Remove the shift gate. (figure 78).

20. Remove the sector through the lock cylinder hole by pushing firmly on the block tooth of the sector with a blunt punch. (figure 79).

21. Remove shift bowl and shroud from the jacket.

22. Remove lower bowl bearing from top of jacket. (figure 80).

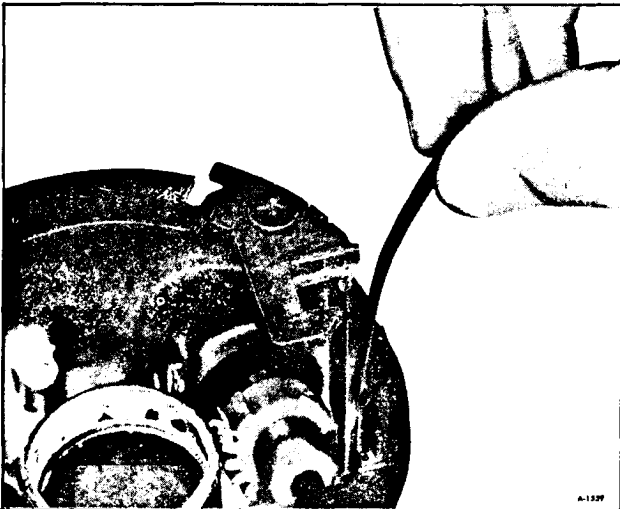

Figure 77-Removing Rack Preload Spring

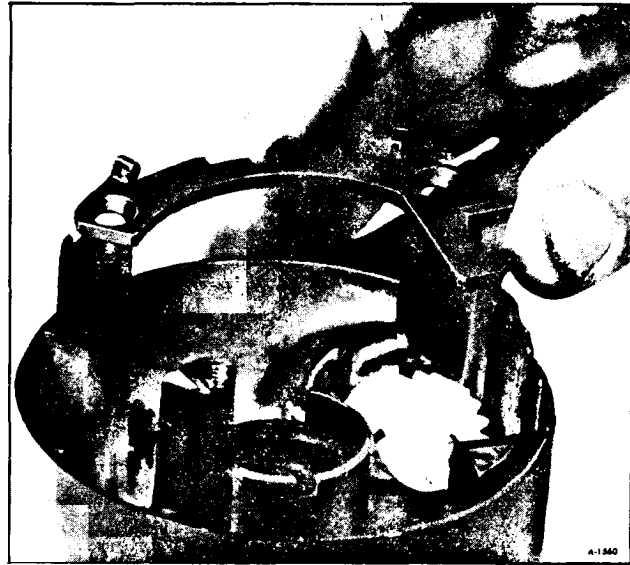

Figure 78-Removing Shift Gate

## DISASSEMBLY OF LOWER END

Steering wheel, cover, lock plate, retaining ring, spring, cancelling cam and flat washer must be removed prior to disassembly of the lower end. Follow instructions above.

1. Pull steering shaft assembly from bottom of column.

2. Remove the two screws holding the neutral-start switch and remove switch. (figure 81).

3. Remove bearing adapter clip. (figure 82).

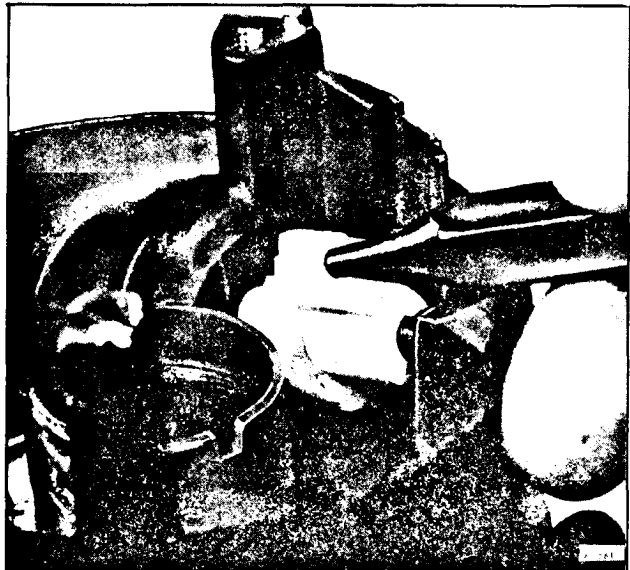

Figure 79-Removing Sector





Figure 80—Removing Lower Bowl Bearing

4. Remove bearing retainer, bearing adapter, and shift tube spring. (figure 83). (Bearing may be removed from adapter by a light press-out operation on the outer race).

5. Slide out shift tube assembly.

## REASSEMBLY OF UPPER END

Apply a thin coat of lithium soap grease to all friction surfaces.

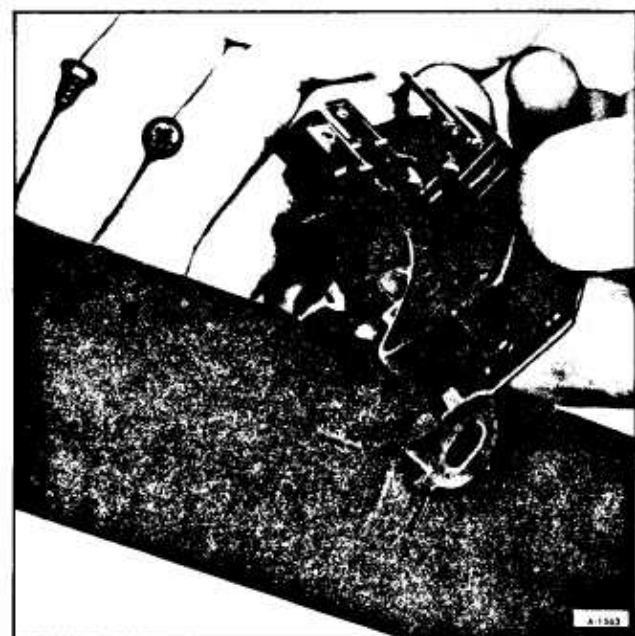

Figure 81—Removing Neutral Start Switch



Figure 82—Removing Bearing Adapter Clip

1. Install the sector in the lock cylinder hole over the sector shaft with the tang end to the outside of the hole. Press the sector over the pin with a blunt tool. (figure 84).

2. Install the shift gate to the housing (45 in-lbs).

3. Insert the rack preload spring in the housing from the bottom side. (figure 77).

4. Assemble the bolt to the cross-over arm of the rack. (figure 85).



Figure 83—Removing Bearing Adapter and Shift Tube Spring



Figure 84—Installing Sector

5. Insert the rack and lock bolt into the housing from the bottom with the teeth up (toward hand-wheel) and toward the centerline of the column. (figure 86).

6. Install the thrust cup on the bottom hub of the housing. (figure 75).

7. Install lower bowl bearing in jacket. (figure 80).

8. Install bowl and rotate it to be sure it is seated in bearing.

9. With the bowl in place, install the upper bearing housing assembly on the jacket.

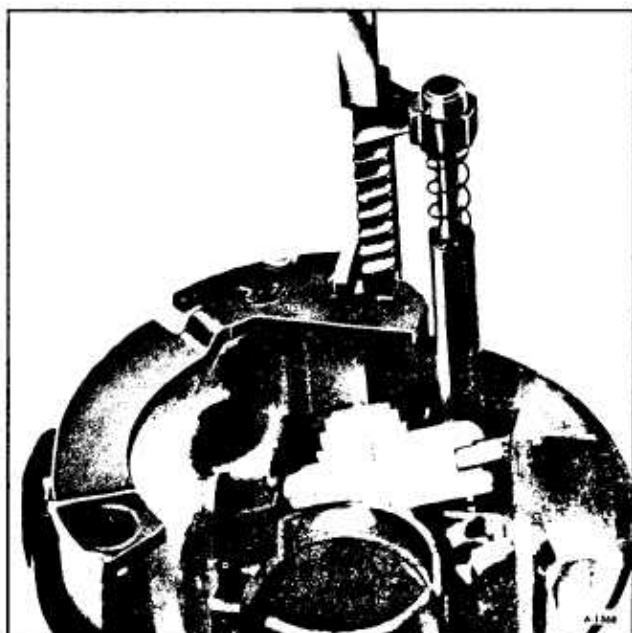

Figure 86—Installing Rack and Lock Bolt

The bowl should be in the "park" position and the rack pulled downward. Be sure the housing is seated on the jacket and drive the screws. (60 in-lbs). (figure 87).

10. Assemble buzzer switch to spring clip with formed end of clip around the lower end of switch and spring bowed away from switch. This should lay on the switch opposite the contacts. Push switch and spring into hole with the internal switch contacts toward the lock cylinder bore. (figure 73).



Figure 87—Installing Upper Bearing Housing Assembly

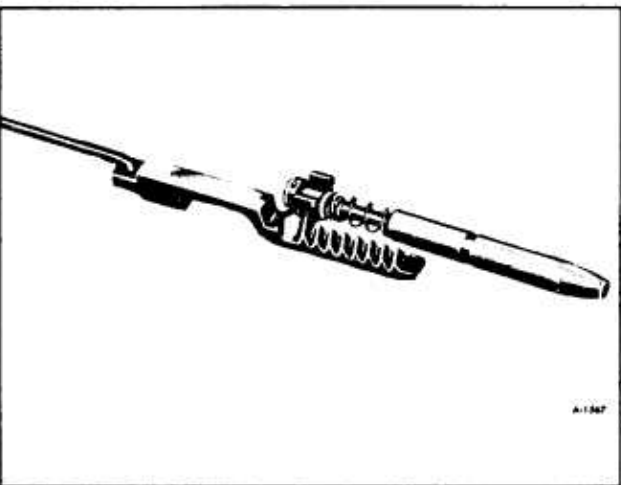

Figure 85—Bolt and Rack Assembly

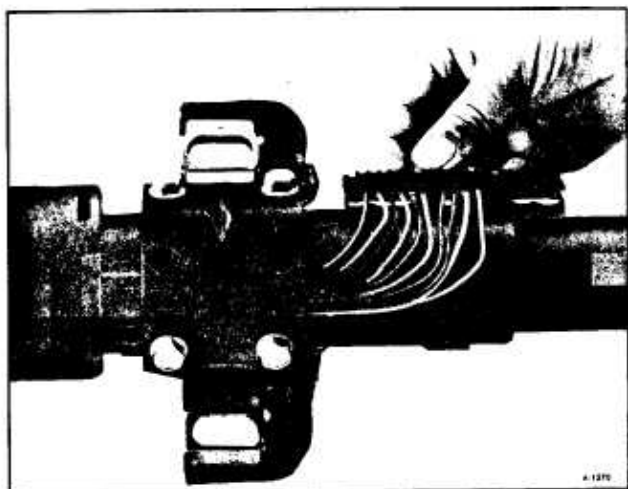

Figure 88—Clipping Connector To Jacket Bracket

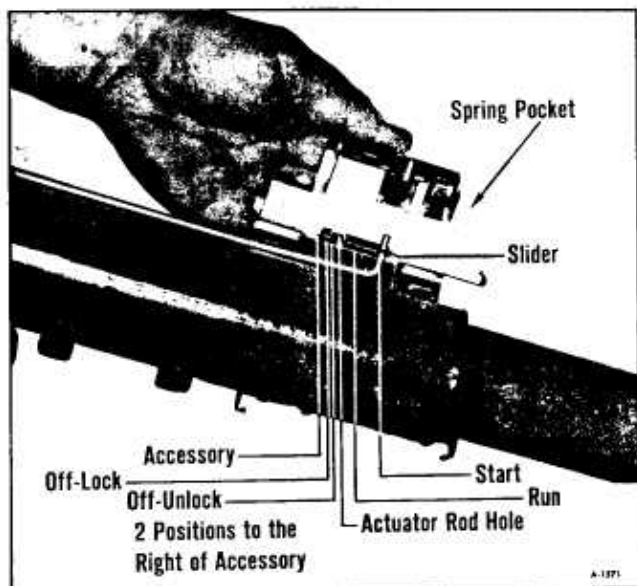

Figure 89—Positioning Ignition Switch

11. Replace the turn signal switch. Feed the connector (bend wires as shown in figure 71) down through the housing. Assemble the wires into the protector and the protector to the jacket. Hold I.P. bracket in place and drive four screws. Clip connector into bracket on jacket. (figure 88).

12. To install lock, hold lock cylinder sleeve and rotate knob clockwise against stop. Insert cylinder into housing bore with key on cylinder sleeve aligned to keyway in housing, push in to abutment of cylinder and sector. Rotate knob counterclockwise, maintaining a light push inward on cylinder, until drive section of cylinder mates with sector. Push in until retainer pops into grooves and lock cylinder is secured in housing. Check freedom of rotation.

13. When replacing the ignition switch, place the shift bowl in any position except "Park" and rotate lock counterclockwise until the rack bottoms against the lower surface of the cast in bowl plate. Place the ignition switch in the "off-unlocked" position by the following procedure.

Position switch as shown in Figure 89.

Move the slider to the extreme left. (Accessory).

Move the slider 2 positions to the right from "accessory" to the "off-unlock" position.

Fit the actuator rod into the slider hole and assemble to the column with two screws. Caution should be exercised to prevent moving the switch out of detent. Use only the correct screws. Tighten to 35 in-lbs.

14. Assemble washer, spring and cancelling cam on shaft, making certain that the turn signal switch is in "neutral" and the hazard warning plunger is

out. Assemble the lock plate on the shaft, depress these parts and install a new retaining ring in groove on shaft. The switch assembly may be damaged if the above procedure is not followed.

15. Place cover on shaft lock and drive screws. (15in-lbs).

16. Assemble steering wheel and levers. Be sure bowl is in "Drive" when inserting shift lever.

## REASSEMBLY OF LOWER END

Apply a thin coat of lithium soap grease to all friction surfaces.

1. Press the lower bearing assembly into adapter assembly. (if removed).

2. Insert the shift tube assembly into the lower end of the jacket and rotate until the upper shift tube key slides into the bowl keyway.

3. Assemble the spring adapter assembly and retainer into the bottom of the jacket. Holding the adapter in place, insert the snap ring into the jacket and mating retainer slots.

4. Install the neutral-start switch, making certain the proper screws are used. (figure 81). (15 in-lbs)

5. Slide steering shaft assembly into column. (The upper housing should be in place before the shaft is assembled.)

## TILT COLUMN OVERHAUL

### DISASSEMBLY OF STEERING COLUMN

1. Disconnect column from lower steering shaft at cinch clamp.

2. Remove column mounting bracket from column and **SET ASIDE TO PROTECT BREAKAWAY CAPSULES.**

3. Mount assembly in vise using tool No. J-23074.

4. Remove steering wheel using wheel puller. **DO NOT HAMMER ON END OF STEERING SHAFT.**

5. Remove signal switch wire protector. **DO NOT DAMAGE WIRES.** (figure 90). Wrap a piece of tape around the upper connector and wires to prevent snagging when removing the switch. (figure 91)

6. Remove three cover screws. Remove shaft lock cover.

7. Remove tilt release lever, signal switch lever, push hazard warning plunger in and remove hazard warning knob. Remove upper shift lever from bowl. Remove indicator wire, if automatic transmission column. Remove neutral start switch.

8. Depress lock plate with finger and pry retaining ring out of groove with screw driver (figure 92).

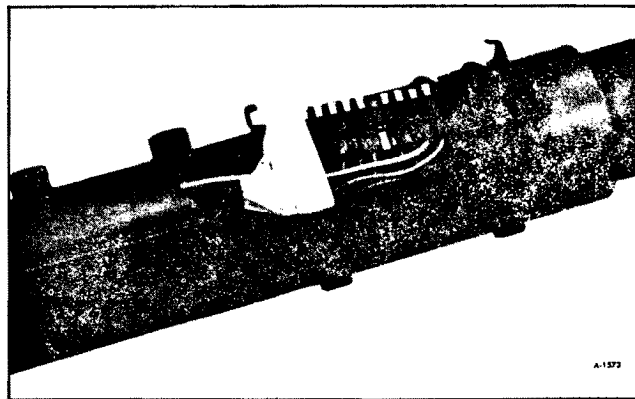

Figure 91—Connector and Wires Taped

Tool J-23653 can be used (figure 93) but the full load of the upper bearing spring should not be relieved as then the retaining ring will turn easily making removal more difficult. Remove lock plate, cancelling cam and upper bearing spring.

9. Remove the three signal switch mounting screws.

10. Position shift bowl in "low" shift position. Pull the switch straight up (figure 94).

11. The lock cylinder should be removed in the "Run" position.

12. Insert a thin tool (small screw driver or knife blade) into the slot next to the switch mounting screw boss (right-hand slot) and depress retainer at



Figure 90—Removing Wire Protector



Figure 92—Removing Retaining Ring



Figure 93—Using Tool to Remove Retaining Ring

bottom of slot, which releases lock. Remove lock (figure 95).

13. The buzzer switch can be pulled straight out of the housing (figure 96). A flat spring wedges the switch toward the lock cylinder (figure 97).

14. Remove three housing cover screws and remove housing cover.

15. Reinstall tilt release lever and place column

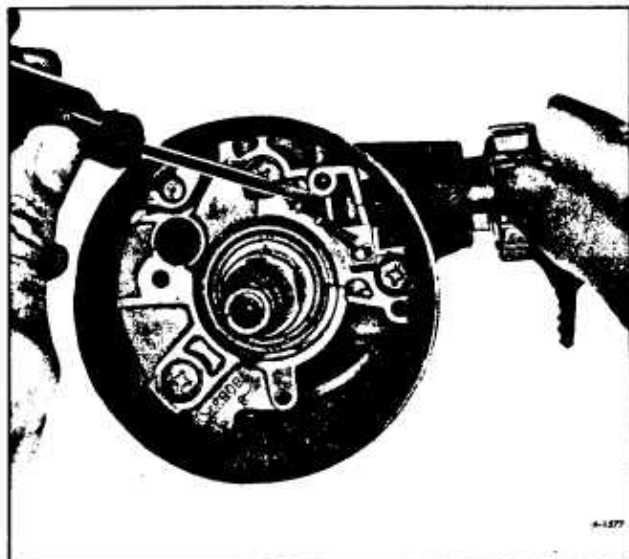

Figure 95—Removing Lock

in full tilt "up" position. Remove tilt spring retainer using screw driver blade that just fits into slot opening. Insert screw driver in slot, press in approximately 3/16 in., turn approximately 1/8 turn counter-clockwise until ears align with grooves in housing and remove spring and guide (figure 98).

16. With the ignition switch in "acc" position, remove two ignition switch mounting screws and ignition switch. Remove two neutral-start switch screws and neutral-start switch.

17. Remove two pivot pins with tool No. J-21854-1 (figure 99). Remove intermediate shaft as-



Figure 94—Removing Signal Switch



Figure 96—Removing Buzzer Switch





Figure 97—Buzzer Switch and Spring Retainer

assembly or lower flange so shaft can be pulled up through column.

18. Disengage lock shoes by pulling on release lever. Remove bearing housing assembly by pulling upward to extend rack full down and moving housing assembly to the left to disengage rack from actuator. Remove actuator rod assembly.

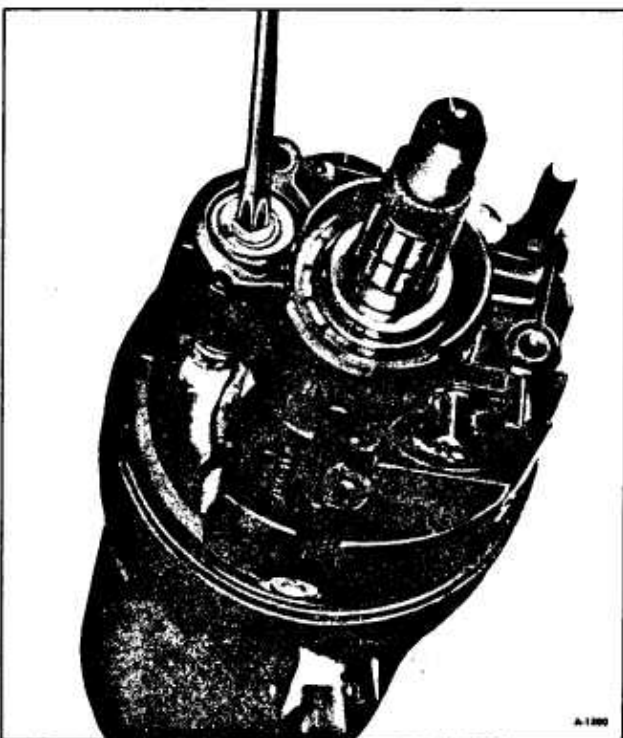

Figure 98—Removing Tilt Spring Retainer



Figure 99—Removing Pivot Pins

19. Remove steering shaft assembly. Remove upper bearing seat and inner race.

20. Disassemble steering shaft assembly by removing center spheres and anti-lash spring.

21. Remove four support screws and remove support assembly.

22. Remove shift tube retaining ring with screw driver. Remove thrust washer.

If service is required on upper end only, steps 1 thru 22 may be performed in the vehicle. It is necessary to remove the mounting bracket and loosen toe plate to prevent bending of jacket and toe plate to service the signal switch.

23. Remove clip, bearing adapter retainer and bearing adapter assembly from lower end of jacket.

24. Remove shift tube from bowl (use tool No. J-23072) (figure 100). Insert bushing on end of tool in shift tube and force tube out of bowl. Care should be taken not to jam lower shift lever into lower jacket. Lever must be aligned with "T" slot to remove shift tube. **DO NOT HAMMER OR PULL ON LOWER OR UPPER SHIFT TUBE BECAUSE PLASTIC JOINT MAY BE SHEARED.**

25. Remove shift tube assembly from jacket from lower end.

26. Remove lock plate by sliding out of jacket notches and tipping down toward bowl hub at 12

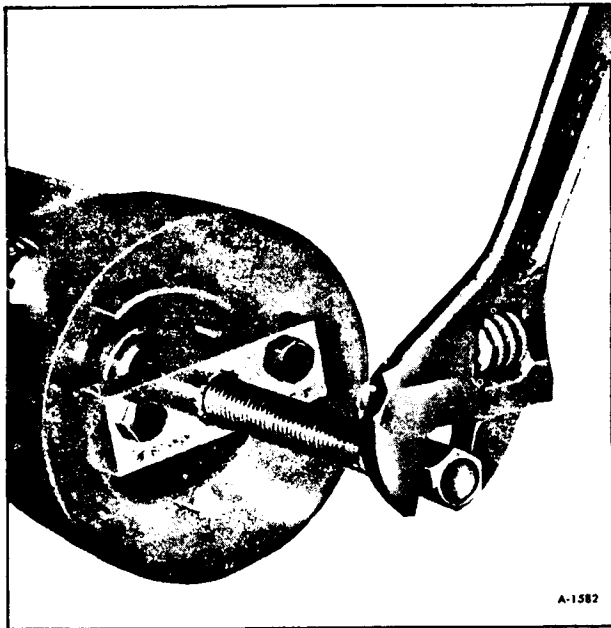

Figure 100—Removing Shift Tube From Bowl



Figure 102—Removing Lock Bolt Spring

o'clock position and under jacket opening. Remove wave washer.

27. Remove bowl from jacket. Remove shift lever spring from bowl by winding spring up with pliers and pulling out.

28. Remove tilt lever opening shield from housing (figure 101).

29. Remove lock bolt spring by removing spring retaining screw and moving spring clockwise to remove from bolt (figure 102).

30. If there is a snap ring, remove it from sector drive shaft. With small punch lightly tap drive shaft from sector (figure 103). Remove drive shaft. Remove rack and rack spring (also shim, if there is one). Remove sector and bolt.



Figure 101—Removing Tilt Lever Shield

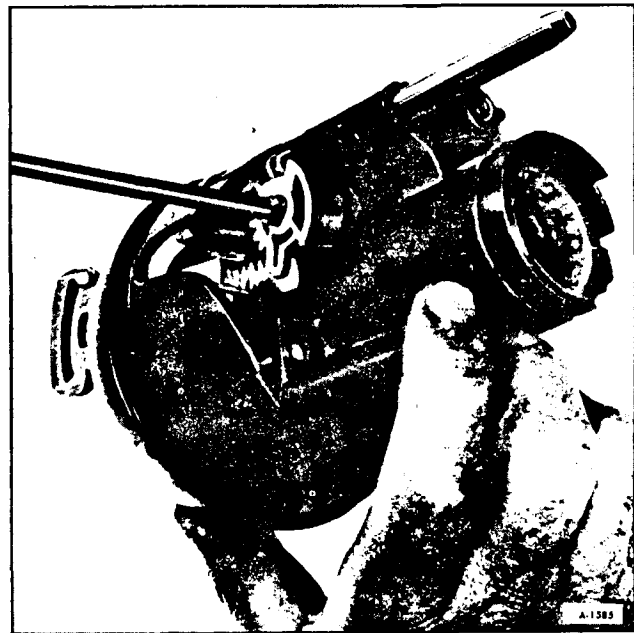

Figure 103—Removing Drive Shaft

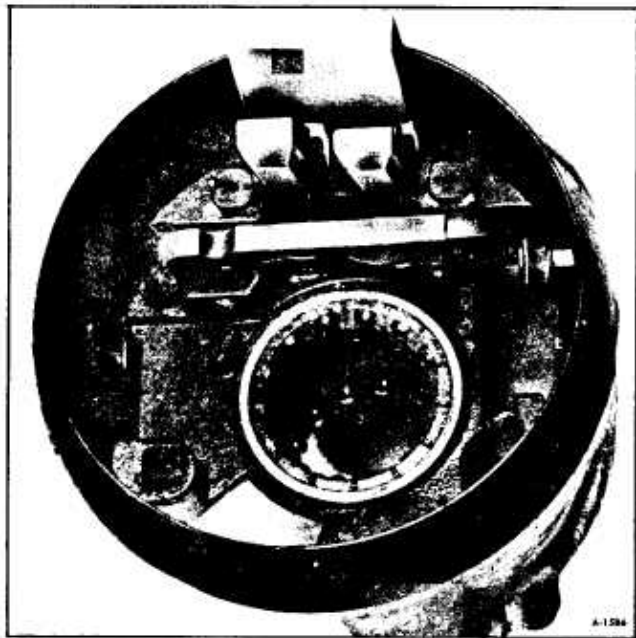

Figure 104—Removing Load on Release Lever

31. Remove tilt release lever pin with pin punch and hammer. Remove lever and release lever spring. (To relieve load on release lever, hold shoes inward and wedge block between top of shoes (over slots and bearing housing) (figure 104).

32. Remove lock shoe pin with punch and hammer. Remove lock shoes and lock shoe springs.

33. Remove bearings from bearing housing only if they are to be replaced. Remove separator and balls from bearing. Place housing on work surface. With a pointed punch against back surface of race, carefully hammer race out of housing until bearing puller can be used. Repeat for other race. Do not re-use bearings.

## ASSEMBLY OF STEERING COLUMN

Apply thin coat of lithium grease to all wear surfaces except lock, bolt and lock bolt hole.

1. Install new bearings in bearing housing, if removed.

2. Install lock shoe springs, lock shoe and shoe pin in bearing housing. Use approximately .180 rod to line up shoes for pin installation.

3. Install spring, release lever and pin in bearing housing. (Again, relieve load on release lever as in step 31 of "Disassembly of Steering Column").

4. Install drive shaft in housing. Lightly tap sector onto the shaft far enough to expose snap ring groove. Replace snap ring if it was removed.

5. Install lock bolt and engage with sector cam surface (figure 102).

6. Install rack and spring. (Replace shim if one was removed). Block tooth on rack to engage block tooth on sector (figure 102). Install external tilt release lever.

7. Install bolt spring and spring retaining screw. Tighten to 35 inch-pounds.

8. Install shift lever spring in bowl by winding up with pliers and pushing in. Slide bowl into jacket.

9. Install wave washer and lock plate into place. Work lock plate into notches in jacket by tipping lock plate toward bowl hub at 12 o'clock position and under jacket opening. Slide lock plate into notches in jacket.

10. Carefully install shift tube in lower end of jacket. Align key in tube with keyway in bowl and use tool No. J-23073 to pull shift tube into bowl (figure 105).

**CAUTION: DO NOT PUSH OR TAP ON END OF SHIFT TUBE.** Install thrust washer and retaining ring by pulling bowl up to compress wave washer.

11. Install support by aligning "V" in support



Figure 105—Installing Shift Tube



with "V" notch in jacket. Insert screws through support in lock plate. Tighten screws to 60 inch-pounds torque.

12. Align lower bearing adapter notches in jacket and push in lower end of jacket. Shift tube should pilot in adapter while this is done. Install adapter retainer and clip.

13. Install centering spheres and anti-lash spring in upper steering shaft. Install lower steering shaft from same side of spheres that spring ends protrude.

14. Install steering shaft assembly in shift tube from upper end. Carefully guide shaft through shift tube and bearing.

15. Install ignition switch actuator rod through bowl from bottom and insert in slot in support. Extend rack downward from bearing housing. Assemble bearing housing over steering shaft and engage rack over end of actuator rod (figure 106).

16. Holding lock shoes in disengaged position, assemble bearing housing over steering shaft until the pivot pin holes line up with the holes in the support.

17. Install pivot pins—assemble as far as possible using palm pressure of hand to prevent broaching of support pivot hole. Once started, tap home with a small hammer and punch.

18. Place housing in full "up" position, install guide, make sure there is grease between the guide and peg on support, tilt spring and tilt spring retainer, using screw driver in retainer slot. Turn retainer clockwise to engage (figure 98).

19. Install tilt lever opening shield in housing (figure 101).

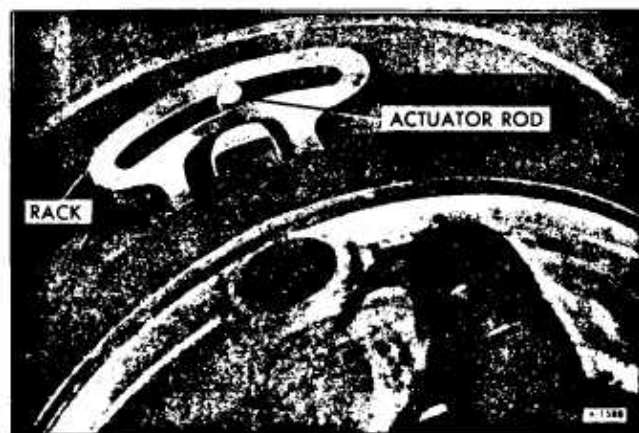

Figure 106—Engaging Rack

20. Remove tilt release lever, install housing cover and seat screw at 12 o'clock position first. Tighten to 100 inch-pounds, 3 screws.

21. Assemble buzzer switch to spring clip with formed end of clip under end of switch and spring bowed away from switch on side opposite contact (figure 97). Push switch and spring into hole in cover to the step with the contacts toward lock cylinder bore.

22. Install signal switch wires and connector through cover, bearing housing and bowl. Push hazard warning knob in, install switch and tighten screws to 25 inch-pounds.

23. Install wave washer (if one is used) and lower steering shaft flange or intermediate shaft assembly. Tighten pinch bolt to specified torque.

24. Install hazard warning knob and pull knob out. Install bearing inner race, seat, bearing preload spring, cancelling cam and lock plate.

25. Depress lock plate and install new retaining ring using tool J-23653 (figure 107).

26. Reinstall tilt release lever, signal switch lever (15 inch-pounds) and hazard warning knob (5 inch-pounds). Install upper shift lever and drive in pivot pin.

27. To install lock, hold lock cylinder sleeve and rotate knob clockwise against stop. Insert cylinder into cover bore with key on cylinder sleeve aligned to keyway in housing. Push in to abutment of cylin-



Figure 107—Installing Retaining Spring

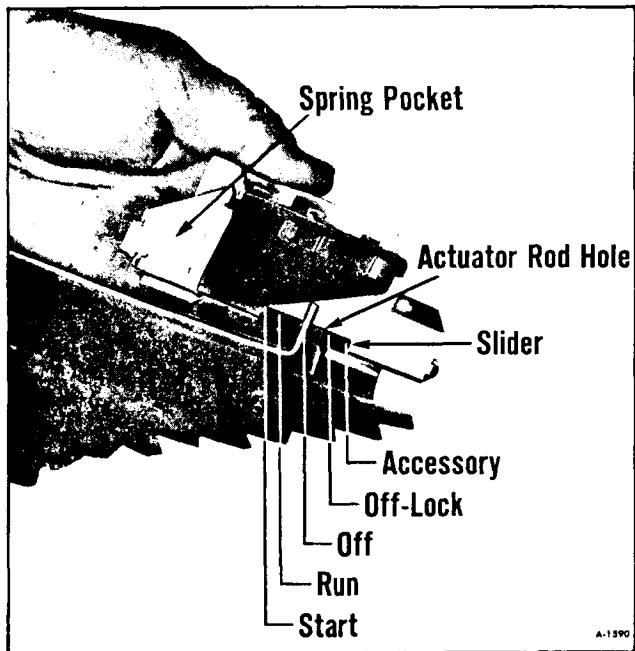

Figure 108—Installing Ignition Switch

der and sector. Rotate knob counterclockwise, maintaining a light push inward on cylinder, until drive section of cylinder mates with drive shaft. Push in until retainer pops into groove. This locks cylinder into cover. Check freedom of rotation.

28. Install shaft lock cover and tighten three screws to 15 inch-pounds.

29. When replacing ignition switch, place the lock in "Acc" position. Place the switch in "acc" by the following procedure:

A. Position the switch as it is shown in Figure 108.

B. Move the slider to the extreme right, to the "acc" position.

Fit the actuator rod into the slider hole and assemble to the column with two screws. Lightly push the switch down the column (away from the steering wheel), to take out lash in the actuator rod, and tighten mounting screws. Caution should be exercised to prevent moving the switch out of detent. Use only the correct screws. Tighten to 35 inch-pounds.

30. Install neutral-start switch and back-up light switch. Do not tighten screws. Neutral-start switch will be adjusted in the car and should be tightened to 20 inch-pounds. **DO NOT SUBSTITUTE SCREWS.**

31. Install lower wire protector over wires and on jacket (figure 90).

32. Install mounting bracket. **DO NOT SUBSTITUTE BOLTS.** (Mounting bracket torque, 15 foot-pounds).

33. Install steering wheel. Torque steering wheel nut to 30 foot-pounds.

34. Install horn parts.

## STEERING COLUMN INSTALLATION (ALL COLUMNS)

Make sure this procedure is followed in exactly this order.

1. Reconnect all electrical connections.

2. Install column into position and loosely attach mounting bracket to instrument panel with two mounting bolts.

**CAUTION:** *Do not use longer bolts or over-torque bolts. The correct bolts and torque are necessary to insure the breakaway action of the bracket and capsules in the event of a collision.*

3. Attach column at coupling. Tighten fasteners to specified torque.

4. Attach column bolts to instrument panel with specified torque.

5. Slide dash mounting plate firmly against dash and install mounting screws.

**CAUTION:** *Make certain that column instrument mounting panel is never unsupported when either dash mounting or gear mounting is connected.*

# TORQUE SPECIFICATIONS

## STEERING LINKAGE

Part	Location	Torque (Ft. Lbs.)
Nut	Steering Arm to Tie Rod End .....	40-50
Nut	Tie Rod Clamp Nuts .....	19-24
Nut	Tie Rod To Intermediate Rod .....	40-50
Nut	Idler Arm To Intermediate Rod .....	40-50
Nut	Idler Arm To Frame .....	85-110
Nut	Relay Lever To Intermediate Rod .....	40-60
Bolt	Relay Lever To Frame .....	250-300
Nut	Drag Link To Relay Lever .....	40-60
Nut	Drag Link To Pitman Arm .....	40-60
Nut	Pitman Arm To Steering Gear .....	160-210

## POWER STEERING PUMP

Part	Torque (Ft. Lb.)
Pulley Nut .....	45-65
Pump Mounting Bolts.....	25-30
Reservoir Bolt .....	25-30
Flow Control Fitting Assm. ....	35
Pressure Hose.....	35

## STEERING GEAR

Part	Torque (Ft. Lb.)
Gear to Frame Bolts .....	70-80
High Pressure Line Fitting (At Gear).....	30
Oil Return Line Fitting (At Gear).....	30
Adjusting Screw Locknut .....	35
Side Cover Bolts .....	35
Adjuster Plug Locknut .....	80
Coupling Flange Nuts.....	20
Return Guide Clamp Screws .....	5
Rack-Piston Plug .....	75
Pitman Shaft Nut .....	160-210
Coupling Flange Bolt .....	30

## STEERING COLUMN

Standard Column	Ft. Lb.
Pinch Bolt, to Steering Shaft .....	30
Pinch Bolt, demountable flange to Steering Gear .....	30
Bolt Nut, pot coupling clamp .....	50

Standard Column	In.-Lb.
Shift Gate Mounting Screws .....	45
Housing Screws.....	60
Signal Switch Mounting Screws.....	25
Ignition Switch Mounting Screws.....	35
Steering Shaft Lock Cover Screw.....	15
Neutral Start Switch Mounting Screws.....	15
Signal Switch Lever Screw .....	15
Bearing Screws (Synchro) .....	90
Hazard Warning Knob .....	5

Tilt Column	Ft. Lb.
Pinch Bolt, to Steering Shaft .....	30
Pinch Bolt, demountable flange to Steering Gear .....	30
Bolt Nut, pot coupling clamp .....	50

Tilt Column	In. Lb.
Spring Retaining Screw.....	35

Tilt Column	In. Lb.
Spring Retaining Screw.....	35
Support Screws.....	60
Housing Screws.....	100
Signal Switch Mounting Screws.....	25
Shaft Lock Cover Screws.....	15
Ignition Switch Mounting Screws.....	35
Neutral Start Mounting Switch Screws.....	20
Tilt Release Lever Screw.....	30
Hazard Warning Knob.....	5
Steering Wheel Nut.....	30
Signal Switch Lever Screw.....	15

## SPECIAL TOOLS

J-23600	Belt Tension Gauge
J-1859-03	Steering Wheel Puller
J-5176-01	Checking Gauge
J-5860	Torque Wrench Adapter
J-6217	Connector Seat Installer
J-6219	Pitman Shaft Seal Installer
J-6222	Stub Shaft Seal Protector
J-6278-1	Pitman Shaft Bearing Remover
J-6278-2	Pitman Shaft Bearing Installer
J-7079-2	Handle
J-7576	Rack Piston Seal Compressor
J-7624	Spanner Wrench
J-7726	Seal Installer
J-7754	Torque Wrench
J-7786	Gauge Adapter
J-8058	Torque Wrench
J-8092	Handle
J-8524-1	Adjuster Plug Bearing Installer
J-8524-2	Adjuster Plug Bearing Remover
J-21552	Ball Retainer
J-21854-01	Pivot Pin Remover
J-22407	Pitman Shaft Bearing Installer
J-22616	Pump Shaft Seal Protector
J-23063	Spring Remover
J-23072	Shift Tube Remover
J-23073-01	Shift Tube Installer
J-23653	Lock Plate Compressor
J-24319	Ball Stud Puller



# SECTION 10 WHEELS AND TIRES

Contents of this section are listed below:

SUBJECT	PAGE NO.
General Description.....	10-1
Tire Traction .....	10-1
Tread Wear .....	10-1
Maintenance.....	10-2
Wheel Studs .....	10-2
Freezing of Nut .....	10-2
Wheel Maintenance .....	10-2
Tire Rotation .....	10-2
Inflation of Tires .....	10-3
Wheel and Tire Balancing.....	10-3
Tire Replacement.....	10-4
Mounting .....	10-5
Demounting .....	10-7
Wheel and Tire Inspection .....	10-7
Wheel and Tire Wear .....	10-7
Wheel Inspection .....	10-8
Specifications .....	10-10

## GENERAL DESCRIPTION

The factory installed tires on the Motor Home are designed to provide the best all-around performance for normal vehicle operation. They are tubeless type, 8.75-16.5, load range D, bias-ply polyester cord. Optional bias-ply steel belted tires are available. Only tires of this size and construction should be used as replacements. Replacement wheels should be equivalent to those removed in diameter, rim width and off-set.

### TIRE TRACTION

A decrease in driving, cornering, and braking traction occurs when water, snow, ice, gravel, or other material is on the road surface. Driving practices and vehicle speed should be adjusted to the road conditions.

When driving on wet or slushy roads, it is possible for a wedge of water to build up between the tire and road surface. This phenomenon, known as hydroplaning, may cause partial or complete loss of traction, which adversely affects vehicle control and stopping ability. To reduce the possibility of traction loss, the following precautions should be observed:

1. Slow down during rain-storms or when roads are slushy.

2. Slow down if road has standing water or puddles.

3. Replace tires when tread wear indicators are visible.

4. Keep tires properly inflated.

### TREAD WEAR (FIGURE 1)

The original equipment tires incorporate built-in tread wear indicators to assist in determining when tires have worn to the point of needing replacement. These indicators appear as 1/2-inch wide bands when tire tread depth is 1/16-inch or less. When the indicators appear in two or more adjacent grooves, tire replacement due to tread wear is recommended.

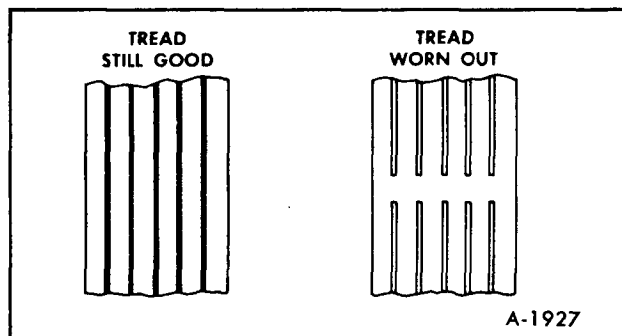

Figure 1-Tread Wear Indicators

# MAINTENANCE

## WHEEL STUDS

### TIGHTENING WHEEL STUD NUTS

When Motor Home is new or after wheels have been replaced, check wheel stud nuts at 500 miles and after every wheel removal thereafter. Nuts should be tightened to 250 foot-pounds torque in sequence shown in Figure 2.

**WARNING: IF ANY WHEEL EXPERIENCES A SINGLE STUD FAILURE CAUSED BY A LOOSE-RUNNING WHEEL, ALL WHEEL STUDS SHOULD BE REPLACED. A LOOSE-RUNNING WHEEL MAY CAUSE ONLY ONE STUD TO BREAK, BUT SEVERAL MORE STUDS MAY BECOME FATIGUED TO THE POINT OF FAILURE, BUT NOT ACTUALLY BREAKING. REPLACING ONLY THE BROKEN STUD AND REMOUNTING WHEEL WILL THEN SET THE STAGE FOR A SECOND AND POSSIBLY MORE SERIOUS FAILURE. IF HOLES IN THE WHEEL HAVE BECOME ELONGATED OR ENLARGED, REPLACE WHEEL.**

Tighten wheel stud nuts as follows:

1. Install all nuts loosely, then finger-tighten only the nuts marked by arrows (figure 2).

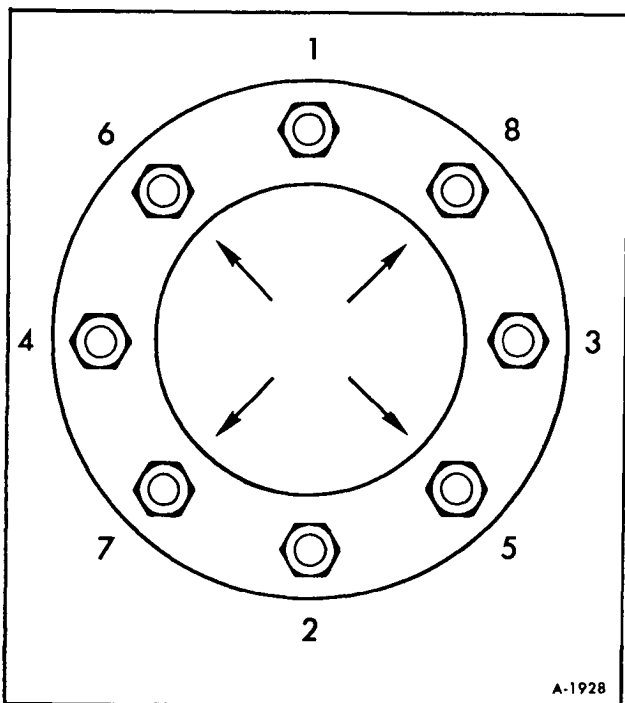

A-1928

Figure 2—Wheel Stud Tightening Sequence

2. Tighten all nuts to specified torque in sequence illustrated. Never use oil or grease on studs or nuts.

## FREEZING OF NUT

Corrosion or galling of the stud and nut assembly can reach a point where removal of cap nuts is difficult. If this is a persistent problem, the threads of the stud and the threads of the inner cap nut should be cleaned with a wire brush.

## WHEEL MAINTENANCE

Thoroughly remove rust, dirt, and other foreign materials from all surfaces. Hand or electric wire brushes, sand blasting or chemical baths may be used.

Bead seat areas of rim should be free of rust and rubber deposits. This is especially important for drop-center tubeless rims, because the 15° bead seat is the air-sealing element.

Paint rim by brush or spray with a fast-drying metal primer. Surfaces should be clean and dry prior to painting. Ensure that bare metal areas on outside or tire side of rim are covered. This is especially important on drop-center tubeless rims, because warm and sometimes moist air is in constant contact with the metal surface on the tire side of the rim.

## TIRE ROTATION

Rotation of the tires will minimize tire trouble and produce longer tire life. With rotation, accelerated and irregular tire wear on any one particular tire will be spread out over several tires, and replacement frequency will be reduced. Tire wear may also contribute to such trouble as poor handling and shimmy.

If desired, the tires should be rotated every 6,000 miles following one of the patterns shown in Figure 3.

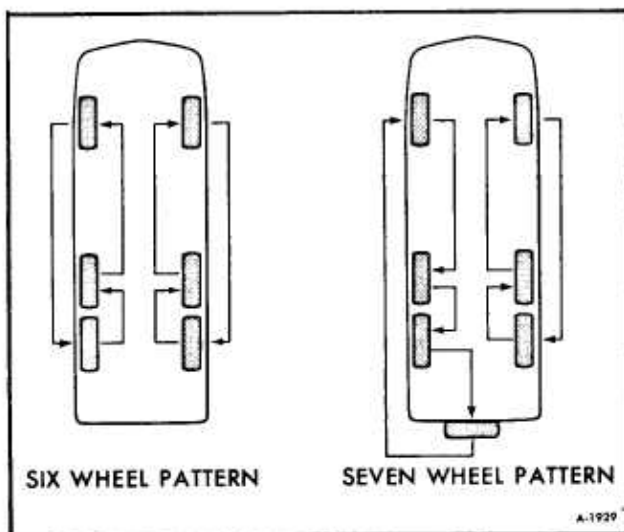

Figure 3-Tire Rotation Diagram

## INFLATION OF TIRES (FIGURE 4)

Inflate to correct pressure when tires are cool. If tires are continually carrying less than the recommended maximum load, adjust air pressure downward to correspond to the actual load carried.

Never "bleed" tires to relieve build-up of pressure. Tire temperature will increase when the tire is in service and allows for the normal build-up in air pressure. Tire temperature and air pressure will remain within limits that are not harmful to the tire when used in accordance with the recommendations for load and air pressure.

If excessive build-up of air pressure occurs, overload, underinflation, speed, or a combination of these is responsible. Use the size and type of tire that has the capacity to carry the load at recommended cold starting pressure.

The fabric, rubber, bead, contour, and size of tires used on these vehicles are designed to obtain maximum length of service under normal operating conditions. TIRES ARE DESIGNED TO OPER-

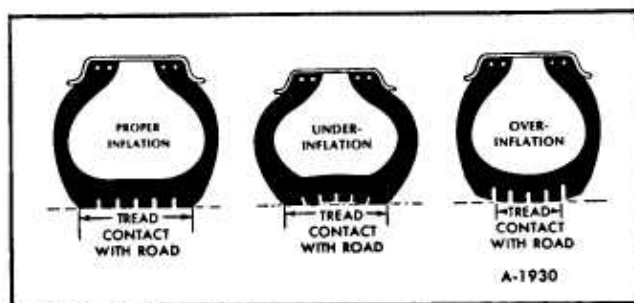

Figure 4-Inflation of Tires

ATE EFFICIENTLY ONLY ON A PRESCRIBED AMOUNT OF AIR. Unless the correct air pressure is consistently maintained, the tires will not function as they should; consistently, safe economical operation of vehicle will be materially affected.

An under-inflated tire runs sluggishly, heats up quickly because of the greater flexing, and is subjected to more frequent bruising.

On the other hand, over-inflation may weaken the tire, causing a blow-out. In addition to the deteriorating effect improperly inflated tires may have on the tire life, this condition will affect steering, riding comfort, and safe driving.

For correct inflation pressure refer to Specifications later in this section.

## BALANCED INFLATION

The whole efficiency of the vehicle will be upset if air pressure in the tires are out-of-balance. Balanced inflation may be expressed as: All tires should always carry the same air pressure. A 5-pound under-inflation in one front tire not only can destroy ease of steering, but creates steering hazards which generally point to a potential accident. An under-inflated rear tire can destroy the value of the most efficient brakes. Balance tires for ease of steering, comfort in riding, safety in driving, as well as for minimum fuel consumption and maximum tire mileage.

## PRESSURE LOSS

At periodic intervals, each tire should be gauged for pressure loss with an accurate gauge before tires are brought to correct operating pressure. The purpose of this check is to determine the exact pressure loss in each tire. In other words, if at the time this check is made, a definite pressure loss is noted in any one of the tires, an inspection should be made of the tire showing the loss and the cause of loss corrected. This method should definitely establish a "danger signal" on the condition of the tires. The pressure loss check should be made consistently with the same gauge, so that any element of inaccuracy in the gauge will be the same for all tires.

## WHEEL AND TIRE BALANCING

It is desirable from the standpoints of tire wear and vehicle handling ease to maintain proper balance



of front wheel and tire assemblies. All wheels intended for use on front of vehicle, such as those switched during periodic tire rotation and those installed as new or repaired replacement equipment should be accurately balanced. This may be accomplished by either of two types of balancing systems in current use which balance wheels either on the vehicle or off. The "on-the-vehicle" type, however, is the more desirable in that all rolling components (brakes, bearings, seals, etc.), are included in the balancing procedure and thereby have any existing unbalance corrected.

Wheel balance is the equal distribution of the weight of the wheel and tire assembly around the axis of rotation. There are two ways in which wheels can be balanced—statically and dynamically.

## STATIC BALANCE

Static balance (sometimes called still balance) is the equal distribution of weight of the wheel and tire assembly about the axis of rotation in such a manner that the assembly has no tendency to rotate by itself, regardless of its position. For example: A wheel with a chunk of dirt on the rim will always rotate by itself until the heavy side is at the bottom. Any wheel with a heavy side like this is statically out-of-balance. Static unbalance of a wheel causes a hopping or pounding action (up and down) which frequently leads to wheel "flutter" and quite often to wheel "tramp."

## DYNAMIC BALANCE

Dynamic balance (sometimes called running balance) means that the wheel must be in static balance,

and also run smoothly at all speeds on an axis which runs through the center line of the wheel and tire and is perpendicular to the axis of rotation.

To ensure successful, accurate balancing, the following precautions must be observed:

Wheel and tire must be clean and free from all foreign matter. The tires should be in good condition and properly mounted with the balance mark on the tire, if any, lined up with the valve.

Bent wheels that have run-out over  $3/32$ " should be replaced.

Inspect tire and wheel assembly to determine if an eccentric or out-of-round condition exists. Note that this condition, if severe, cannot be "balanced out." An assembly which has an out-of-round condition exceeding  $5/16$ " is not suitable for use on the front of the vehicle. Its use on the rear should be governed by its general condition and whether the roundness defect seriously detracts from overall ride quality.

**WARNING: WHEN BALANCING TIRES ON THE VEHICLE, FOLLOW THE EQUIPMENT MANUFACTURER'S INSTRUCTIONS CAREFULLY. DRIVE WHEEL SPIN SHOULD BE LIMITED TO 35 MPH AS INDICATED ON THE SPEEDOMETER. THIS LIMIT IS NECESSARY BECAUSE THE SPEEDOMETER ONLY INDICATES ONE-HALF OF THE ACTUAL WHEEL SPEED WHEN ONE DRIVE WHEEL IS SPINNING AND THE OTHER DRIVE WHEEL IS STOPPED. UNLESS CARE IS TAKEN IN LIMITING DRIVE WHEEL SPIN, THE SPINNING WHEEL CAN REACH EXCESSIVE SPEEDS, RESULTING IN POSSIBLE TIRE DISINTEGRATION OR DIFFERENTIAL FAILURE, WHICH COULD CAUSE PERSONAL INJURY OR EXTENSIVE VEHICLE DAMAGE.**

# TIRE REPLACEMENT

When tires are mounted on dirty or corroded rims, or when they are not properly centered on rims, the tire bead may "bind" on the rim, and refuse to seat. Allowing pressure to continue to build up within the assembly in an attempt to seat the tire bead is a **DANGEROUS PRACTICE** which can result in a broken tire bead, and serious injury to the serviceman. All of the following safety precautions should be observed:

1. Make sure that rim flanges and bead ledge (especially hump and radius) areas are smooth and

clean. Remove any oxidized rubber, dried soap solution, rust, heavy paint, etc., with a wire brush, or in extreme cases, a file.

**NOTE:** Repaint bare metal with a good grade of aluminum paint or equivalent, to prevent rust.

2. Lubricate tire beads, rim flanges, and bead ledge areas with a liberal amount of thin vegetable oil soap solution, or approved rubber lubricant.

3. Ensure that air pressure build-up during the





Figure 5—Lubricating Tire Bead



Figure 6—Working Bead Onto Rim

bead seating process is not allowed to exceed 100 pounds pressure.

**IMPORTANT:** If beads have not seated by the time pressure reaches 80 pounds, assembly should be deflated, repositioned on rim, relubricated, and re-inflated.

4. Make sure valve core is inserted in valve stem prior to inflating.

5. Use an extension gauge with clip on chuck so air pressure build-up can be closely watched and so that you can stand well back from the assembly during the bead seating process to avoid possibility of personal injury.

## MOUNTING

1. Inspect rim to insure bead seats are clean and smooth. Then place rim on floor with wide side down and lubricate first bead of tire and upper bead seat of rim (figure 5).

2. Push first bead into well of rim and onto rim as far as possible. Using straight end of tire iron and with stop resting on rim flange, work remaining section of first bead over rim (figure 6).



Figure 7—Working Second Bead Onto Rim



Figure 8—Inserting Tire Iron to Lift Bead



Figure 10—Inserting Tire Iron in Second Bead



Figure 9—Lifting Bead Over Rim



Figure 11—Prying Second Bead from Rim

3. Hold second bead in well by standing on tire. When necessary, push section of bead into rim well and anchor with vise-grip pliers by pinching pliers on rim flange. Using spoon end of tire iron with stop toward rim, work progressively around bead using small bites until bead slips over flange onto rim base. If necessary, insert second tire iron and lubricate last 6" of bead before completing mounting (figure 7).

4. Check valve to be certain that hex nut at the valve base is tight. Inflate tire to recommended operating pressure. Check assembly for air leaks.

## DEMOUNTING

1. Remove valve core to completely deflate tire. With tire lying flat on floor, loosen beads from rim

seats by walking around on tire with heels at points close to rim. With wide side of rim down, apply tire lubricant to top bead. With stops toward rim, insert spoon ends of two tire irons about 10" apart. While standing on tire to hold bead in gutter, pull one tool toward center of rim (figure 8).

2. Hold one iron in position with foot and pull second iron toward center of rim. Progressively work bead off rim, taking additional bites if necessary (figure 9).

3. Stand assembly in vertical position. Lubricate second bead. At top of assembly insert straight end of tire iron between bead and back flange of rim at about a 45 degree angle (figure 10).

4. Turn iron so that it is perpendicular to rim. Pry second bead off (figure 11).

# WHEEL AND TIRE INSPECTION

## WHEEL AND TIRE WEAR

### CORRECTING IRREGULAR TIRE WEAR

Heel and Toe Wear – This is a saw-toothed effect where one end of each tread block is worn more than the other. The end that wears is the one that first grips the road when the brakes are applied.

Heel and toe wear is less noticeable on front tires than on rear tires, because the propelling action of the front wheels creates a force which tends to wear the opposite end of the tread blocks. The two forces, propelling and braking, make for more even wear of the front tires, whereas only the braking forces act on the rear wheels, and the saw-toothed effect is more noticeable.

A certain amount of heel and toe wear is normal. Excessive wear is usually due to high speed driving and excessive use of brakes. The best remedy, in addition to cautioning the owner on his driving habits, is to rotate tires regularly.

Side Wear – This may be caused by incorrect wheel camber, underinflation, high cambered roads or by taking corners at too high a rate of speed.

The first two causes are the most common. Camber wear can be readily identified because it occurs only on one side of the treads, whereas underinflation causes wear on both sides. Camber wear requires correction of the camber first and then interchanging tires. There is, of course, no correction for high cambered roads. Cornering wear is discussed further on.

Misalignment Wear – This is wear due to excessive toe-in or toe-out. In either case, tires will revolve with a side motion and scrape the tread rubber off. If misalignment is severe, the rubber will be scraped off of both tires; if slight, only one will be affected.

The scraping action against the face of the tire causes a small feather edge of rubber to appear on one side of the tread and this feather edge is certain indication of misalignment. The remedy is readjusting toe-in, or rechecking the entire front end alignment if necessary.

Cornering Wear – When a vehicle makes an extremely fast turn, the weight is shifted from an even loading on all wheels to an abnormal load on the tires on the outside of the curve and very light load on the inside tires, due to centrifugal force. This unequal loading may have two unfavorable results.

First, the front tires on the inside of the curve may be relieved of so much load that it is no longer geared to the road and it slips, grinding off the tread on the inside half of the tire at the excessive rate. This type of tire shows much the same appearance of tread wear as tire wear caused by negative camber.

Second, the transfer of weight may also overload the outside tires so much that they are laterally distorted resulting in excessive wear on the outside half of the tire, producing a type of wear like that caused by excessive positive camber.

Cornering wear can be most easily distinguished from abnormal camber wear by the rounding of the

outside shoulder or edge of the tire and by the roughening of the tread surface which denotes abrasion.

Cornering wear often produces a fin or raised portion along the inside edge of each row in the tread pattern. In some cases this fin is almost as pronounced as a toe-in fin, and in others, it tapers into a row of tread blocks to such an extent that the tire has a definite "step wear" appearance.

The only remedy for cornering wear is proper instruction of operations. Driving more slowly on curves and turns will avoid grinding rubber off tires. To offset normal cornering wear as much as possible, tires should be rotated at regular intervals.

**Uneven Wear** – Uneven or spotty wear is due to such irregularities as unequal caster or camber, bent front suspension parts, out-of-balance wheels, brake drums out-of-round, brakes out of adjustment or other mechanical conditions. The remedy in each case consists of locating the mechanical defect and correcting it.

**Power and Speed** – Excessive speed has always been harmful to tires. Speed creates heat – heat softens tires.

**Stops and Starts** – Quick stops and starts grind off tread in a hurry, may cause flat spots which continue to grow for the life of the tire.

**Temperature** – Considerably less mileage can be expected from a tire used in all warm weather driving as compared to all cool weather driving, or from a tire first put into service in warm weather.

## MECHANICAL IRREGULARITIES

Following are some wheel or vehicle irregularities which may cause rapid or uneven tread wear:

**Toe-In** – The wheels on the same axle are closer together in the front than they are in the rear. When toe-in is excessive the tire wear shows feathered edges on inside edge of the skid design.

**Toe-Out** – The wheels on the same axle are closer together in the rear than they are in the front. Tire wear shows feathered edges on outside edge of the skid design.

**Camber** – This designates the tilt of the wheel. Positive camber is when wheels are closer together at point of road contact. Negative camber is when wheels are closer together at top. Too much camber results in excessive wear on one side of tire.

**Caster** – This is the backward tilt of the axle or inclination of the kingpin at the top. Too little caster causes wheel to wander or weave – result, spotty wear. Excessive caster may cause wheel "flight" or shimmy wear. Unequal caster causes wheel to pull to one side, resulting in excessive and uneven wear.

**Sprung or Twisted Frame** – Will cause rapid or uneven tread wear.

**Grabbing Brakes** – Brakes out of adjustment and out-of-round brake drums or discs cause tire treads to wear rapidly in spots. Out-of-round brake drums usually wear out tires in a single spot. Improperly adjusted brakes produce several worn places.

Worn wheel bearings, unbalanced wheels, or wobbly wheels all result in uneven and irregular tread wear.

At first sign of uneven tire tread wear, check and correct all mechanical irregularities.

## WHEEL INSPECTION

Do not use wheels with bent rims. The continued use of such wheels will result in excessive tire wear and, if wheel is mounted on front of vehicle, difficulty in steering will be experienced. Wheels that are thought to be distorted may be checked as follows, referring to Figure 12 for checking points:

1. Raise wheel at side to be checked and safely support underneath.

2. Tool for checking run-out may be readily improvised as follows:

Secure block of wood approximately 6" x 6" x 14" or material with suitable base so it will remain positioned. Secure thin piece of wood or suitable material 10 inches long, such as ruler or yardstick, and fasten to wood block to a height in relation to rim surfaces as shown in Figure 12. Tighten screw sufficiently so pointer will hold its position when adjusted.

3. Position pointer at crown of rim (A, figure 12). Slowly revolve wheel and move pointer toward wheel until it contacts wheel at nearest point.

4. Continue to revolve wheel and check amount of lateral run-out (amount of wheel side wobble). This should not exceed 3/32-inch.

5. Place point of marker at inside of wheel at point "B", in Figure 12. Follow the previous procedure to check radial run-out (out-of-round condition); this should not exceed 3/32-inch. If wheel is

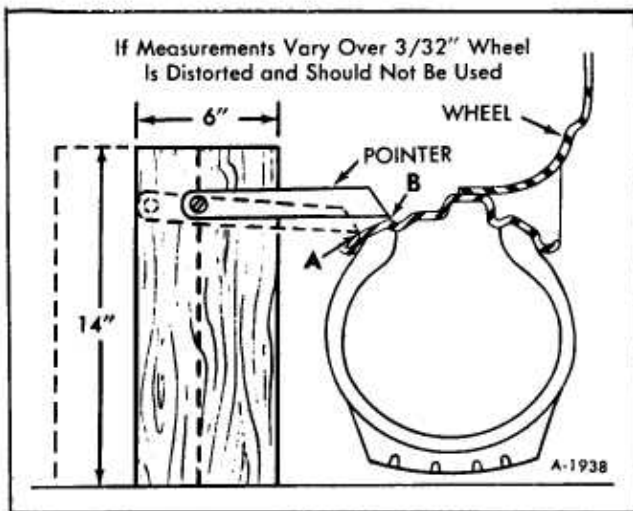

Figure 12—Method of Checking Distorted Wheels

distorted beyond these dimensions it should be replaced.

6. If doubt exists whether the wheel or hub is distorted, hub may be checked as follows: Replace the existing wheel with a wheel known to be true. Revolve the wheel and make the previously mentioned tests. If tests are within limits, the hub is satisfactory, but wheel is sprung.

7. A dismantled wheel may be checked for side wobble by placing a straight-edge on face or hub of wheel. Measure distance from straight-edge to edge of wheel rim, this should be checked at four equally spaced locations. If distance is the same at all positions wheel is not distorted. (See figure 13) A dismantled wheel may also be checked for radial, and lateral run-out if desired, by temporarily mounting it to a hub on vehicle. Follow the previous Steps 2, 3, 4, and 5.

## WORN WHEEL STUD HOLES (FIGURE 14)

This condition will usually be accompanied by appearance of a shiny worn surface on wheel face, indicating that loose wheels were moving against

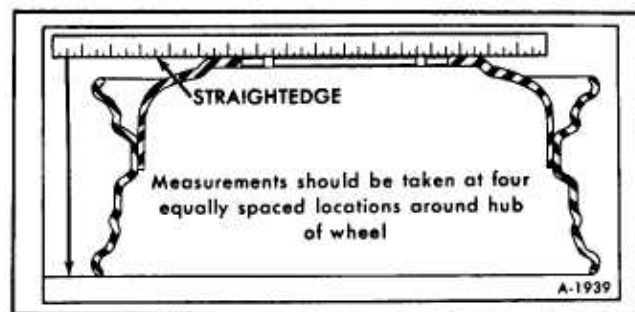

Figure 13—Wheel Checking Diagram

each other. If the stud holes are out of shape – oval or egg shaped – and where a build-up of metal is around them, these wheels must be replaced.

## CRACKED DISC WHEELS (FIGURE 14)

Cracks running from hand-hole to stud-hole or bolt-hole to center-hole or hand-hole to hand-hole, or stud-hole to stud-hole, are a direct result of overloading. Check working loads of vehicle, discard damaged wheels, check wheel studs and complete assembly.

The hub assembly may have a worn mounting face as a result of moving of the wheel on the hub. The studs may have turned in the hub and worn the stud groove or the studs may have actual cracks or breaks resulting from this condition. The wheel may have worn ball seats in the stud holes. All these possibilities must be checked and all damaged parts replaced.

## RUST STREAKS ON DISCS EMANATING FROM STUD HOLES

This is a positive indication that the cap nuts are, or have been, loose. In this case, the assembly should be checked carefully because damage to hub, studs, or wheel may have been caused by running in this condition.

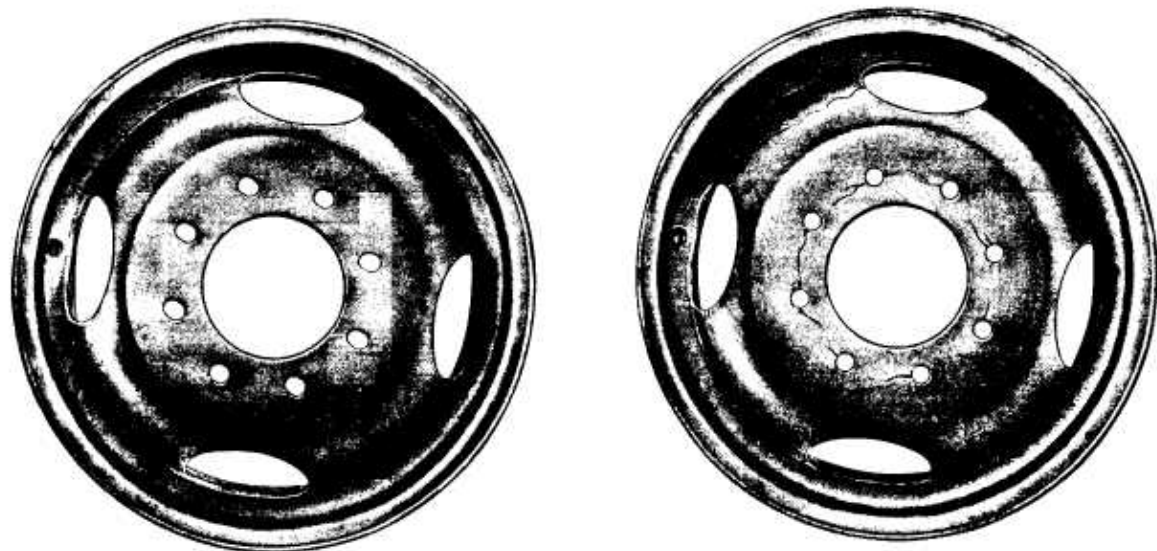

Figure 14—Worn Stud Holes and Cracked Disc Wheels

## SPECIFICATIONS

Inflation Pressure (Cold).....	60 PSI
For Sustained Speeds Over 65 MPH .....	70 PSI
<b>Tires</b>	
Size .....	8.75–16.5
Load Range .....	D
Construction.....	Bias-Ply polyester Cord, Bias-Ply Steel Belted
<b>Wheels</b>	
Diameter.....	16.5"
Width .....	6.0"
Off Set .....	4.67"



# SECTION 12

## CHASSIS ELECTRICAL

Contents of this section are listed below:

SUBJECT	PAGE NO.
Instruments and Gauges .....	12- 1
Component Replacement .....	12- 2
Fuses and Fusible Links .....	12- 5
Printed Circuits .....	12- 6
Gauge Cluster .....	12- 6
Gauge Diagnosis Details .....	12- 7
Low Fuel Indicator Circuit .....	12-11
Miscellaneous .....	12-11
Wiring .....	12-13
General Maintenance .....	12-13
Left-Side Body Wiring .....	12-14
Front Wiring .....	12-14
Instrument Panel Wiring .....	12-14
Steering Column Wiring .....	12-14
Rear Body Wiring .....	12-15
Trailer Wiring .....	12-15
Lighting System .....	12-17
Headlamp Adjustment .....	12-17
Component Replacement .....	12-19
Fiber Optic Ribbon .....	12-20
Headlight Switch .....	12-23
Directional Signals .....	12-23
Dimmer Switch .....	12-23
Horn .....	12-23
Horn Diagnosis .....	12-24
Component Replacement .....	12-24
Radio and Tape Player .....	12-26
Radio and Tape Diagnosis .....	12-29
Servicing .....	12-29
Mobile Radio Transmitters .....	12-31
Cruise Control .....	12-31
General Description .....	12-31
Component Operation .....	12-31
Diagnosis .....	12-37
Servicing .....	12-37
Brake Release Switches .....	12-37
Engagement Switch .....	12-37
Servo .....	12-38
Regulator .....	12-38
Electrical System Check Out .....	12-38
Engagement Switch Test .....	12-39
Light Bulb Specifications .....	12-40

## INSTRUMENTS AND GAUGES

All instruments and gauges are installed in the instrument cluster as shown in Figure 1.

The instrument panel gauges utilize printed cir-

uits. They are connected to the vehicles wiring through a multiple terminal connectors which are plugged into the back side of the gauges.



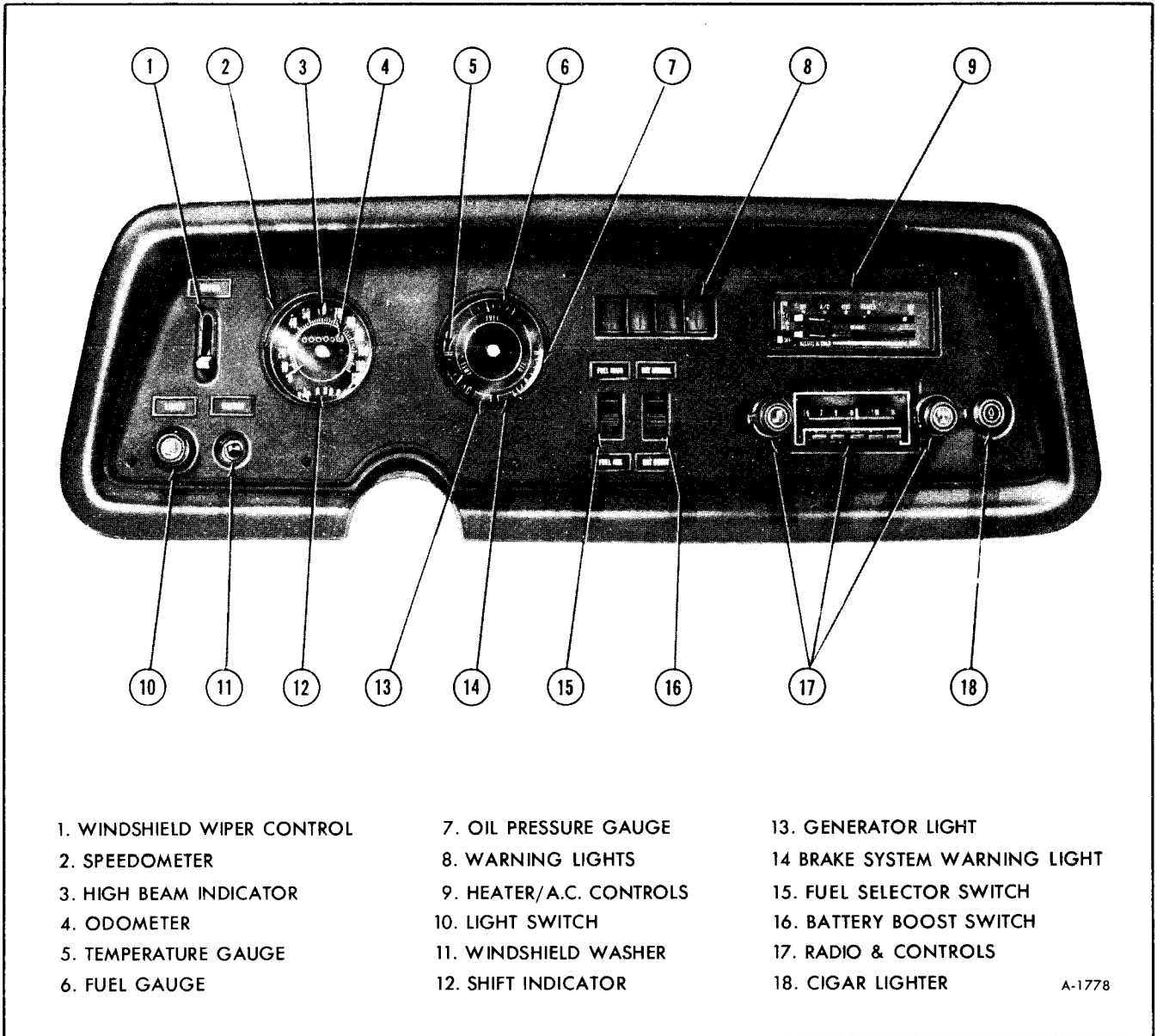

- |                             |                         |                                |
|-----------------------------|-------------------------|--------------------------------|
| 1. WINDSHIELD WIPER CONTROL | 7. OIL PRESSURE GAUGE   | 13. GENERATOR LIGHT            |
| 2. SPEEDOMETER              | 8. WARNING LIGHTS       | 14. BRAKE SYSTEM WARNING LIGHT |
| 3. HIGH BEAM INDICATOR      | 9. HEATER/A.C. CONTROLS | 15. FUEL SELECTOR SWITCH       |
| 4. ODOMETER                 | 10. LIGHT SWITCH        | 16. BATTERY BOOST SWITCH       |
| 5. TEMPERATURE GAUGE        | 11. WINDSHIELD WASHER   | 17. RADIO & CONTROLS           |
| 6. FUEL GAUGE               | 12. SHIFT INDICATOR     | 18. CIGAR LIGHTER              |

A-1778

Figure 1—Instrument Panel

Instruments and gauges can be serviced in the vehicle by removing the instrument bezel as described later in this section. Illumination and indicator lamps can be replaced without removing the gauges and are of a 1/2 turn locking type with printed circuit connections. Regular maintenance is not required on the instrument cluster other than maintaining clean, tight electrical connections, replacing defective parts and keeping the speedometer cable properly lubricated. Figure 2 shows instrument panel component installation.

### INSTRUMENT PANEL BEZEL REPLACEMENT

1. Remove the radio knobs and control rings.

2. Remove the headlight switch knob as described under "HEADLIGHT SWITCH REPLACEMENT" later in this section. Then remove wiper control knob.

3. Disengage the fiber optic ribbon from the source bulb assembly located on the lower left side of the instrument panel assembly. This can be serviced from below the dash panel.

4. Remove the (4) upper bezel edge retaining screws and remove bezel from instrument panel.

5. To install, hook lower edge of the bezel on instrument panel edge and reverse steps 1-4 above.



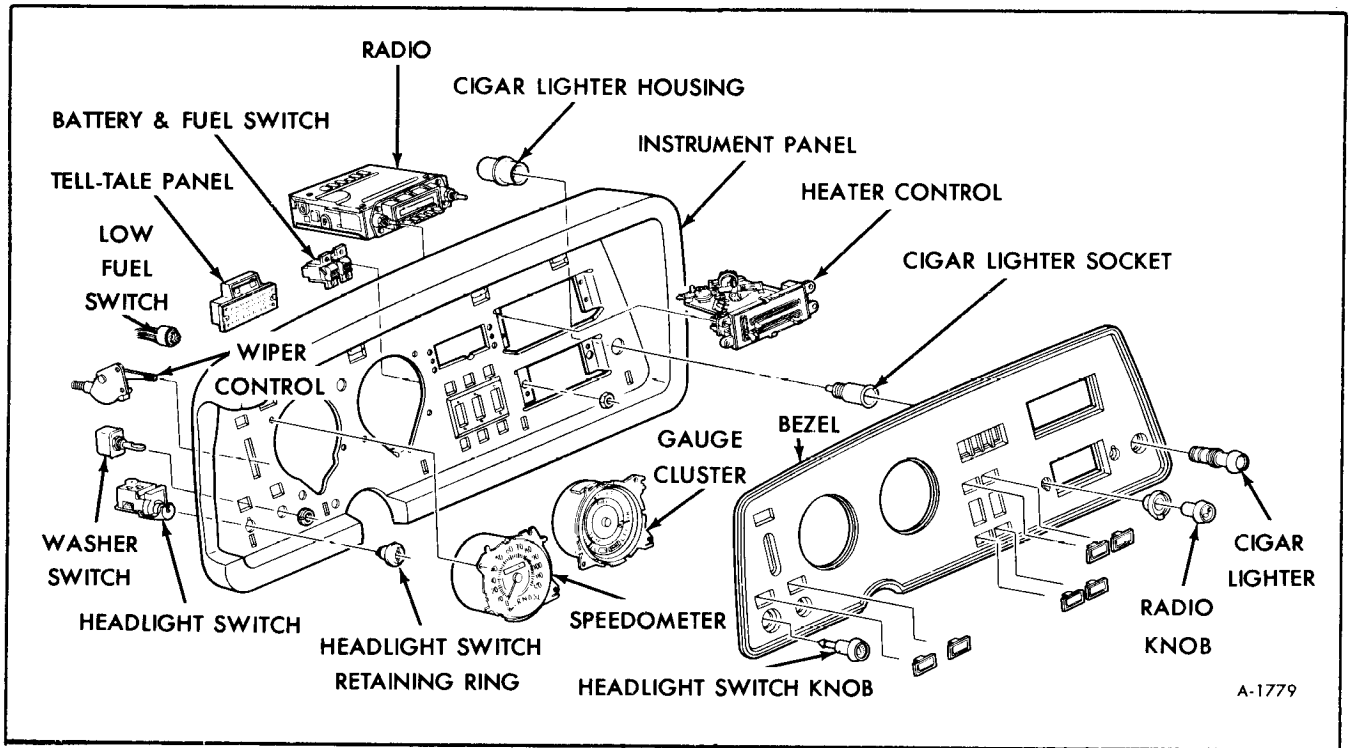

Figure 2—Instrument Panel Components

### INSTRUMENT PANEL REAR COVER REPLACEMENT

1. Remove the (2) cover retaining screws on each side of the cover.
2. Lift cover straight up and work from behind the cluster assembly.
3. To install, reverse steps 1–2.

### SPEEDOMETER HEAD REPLACEMENT

1. Disconnect battery ground cables.
2. Remove instrument panel bezel.
3. Remove instrument panel rear cover.
4. Remove the (3) speedometer retaining screws (See figure 3) and ground wire.
5. Hold the speedometer cable spring retaining clip down and pull cable away from speedometer head.
6. Disconnect (4) wire electrical connector from the back of the speedometer head.

7. Pull the speedometer head out and disconnect the transmission gear indicator cable.

8. Remove the speedometer head from the instrument panel.

9. When installing new or repaired speedometer head, the gear indicator cable should be routed around the metal post on the back side of the instrument panel. (See figure 4)

10. Reverse steps 1–8 to install speedometer head and test operation.

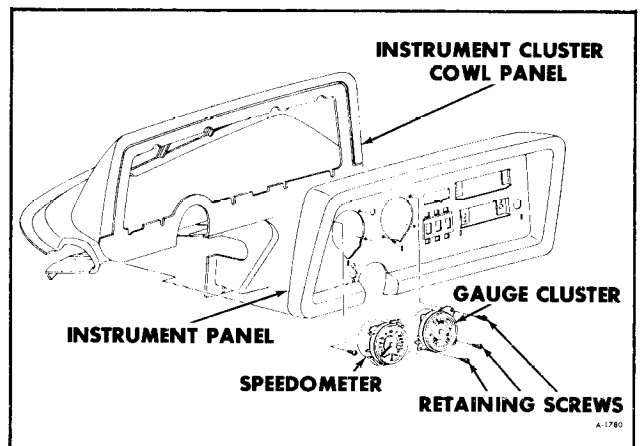

Figure 3—Speedometer and Gauge Cluster

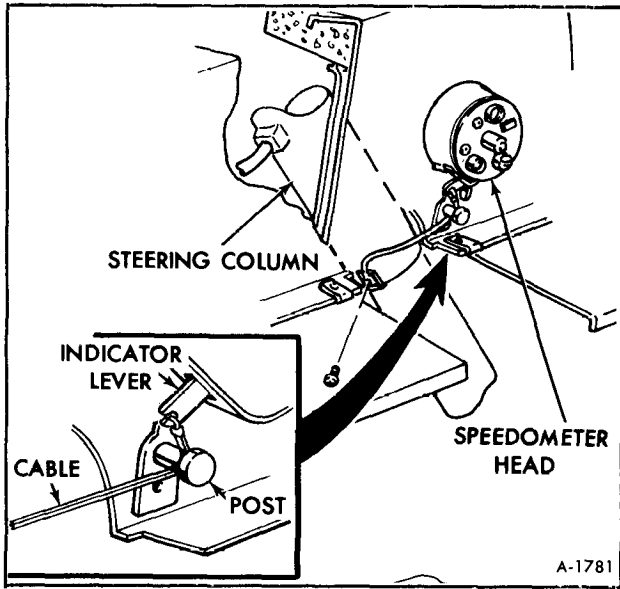

Figure 4—Gear Indicator Cable Connection

### GAUGE CLUSTER REPLACEMENT (FIGURE 3)

1. Disconnect battery ground cables.
2. Removal the instrument panel bezel.
3. Remove the (3) gauge retaining screws and pull gauge out as far as possible. (See figure 3)
4. Disconnect the 7 wire pin connector from the gauge and remove gauge.
5. To install, reverse steps 1–4 above and check operation.

### BATTERY SELECTOR SWITCH REPLACEMENT

1. Disconnect battery ground cables and remove instrument panel bezel.
2. Remove the (2) switch retaining screws shown in Figure 5.
3. Pull switch out as far as possible and disconnect the connector from the switch.
4. To install switch, reverse steps 1–3.

### FUEL SELECTOR SWITCH REPLACEMENT

1. Disconnect battery ground cables and remove instrument panel bezel.

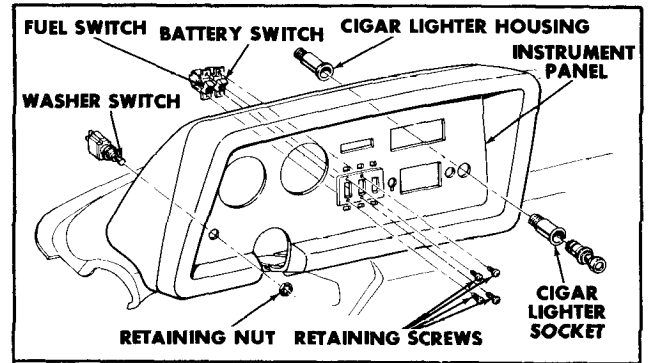

Figure 5—Battery and Fuel Switch Installation

2. Remove the (2) switch retaining screws shown in Figure 5.
3. Pull switch out as far as possible and disconnect the connector from the switch.
4. To install switch, reverse steps 1–3.

### TELL-TALE LIGHT PANEL REPLACEMENT

1. Disconnect the battery ground cables.
2. Remove the instrument panel rear cover.
3. Disconnect the tell-tale light panel electrical connector.
4. Remove the (2) panel retaining screws and remove the panel (See figure 6).
5. To install, reverse steps 1–4.

### CIGAR LIGHTER REPLACEMENT

1. Remove the element portion of the lighter from the instrument panel.
2. Disconnect the battery ground cables.
3. Remove the rear instrument panel cover by removing the (2) screws at each side of the rear panel cover. Lift rear panel cover up and work out of instrument panel.
4. Locate the cigar lighter connector and remove from lighter housing.
5. Turn the lighter housing (rear) counter-clockwise while holding the front portion, remove the lighter assembly when the (2) pieces disengage. (See figure 5)

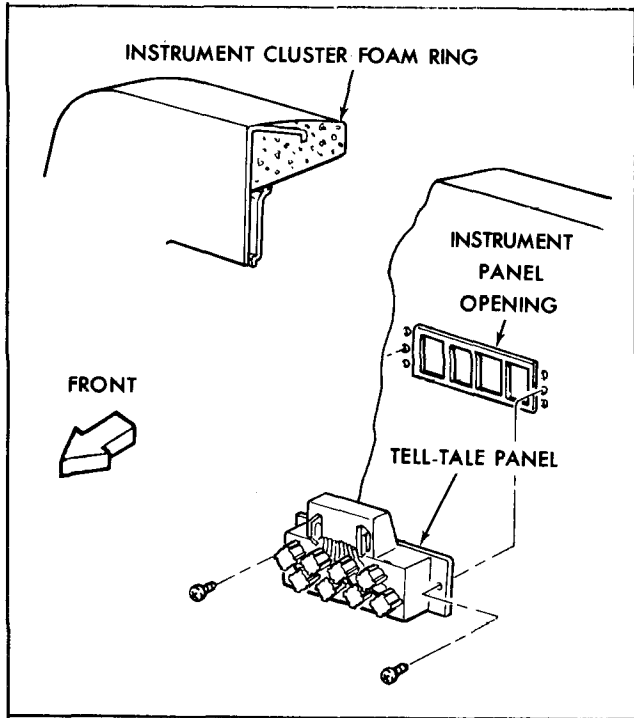

Figure 6-Tell-Tale Light Panel

6. To install lighter, reverse steps 1-5 and check operation.

### SPEEDOMETER CABLE

The speedometer and odometer are driven by a gear train in the speedometer head, which is driven through a flexible shaft that is connected to the transmission. With cruise control, the speedometer cable is a two piece cable running from the speedometer head to the regulator unit and from there to the transmission.

#### Replacement

1. Disconnect the battery ground cables.
2. Remove rear instrument panel cover.
3. Disconnect speedometer cable from head by depressing spring clip and pulling cable core out of speedometer end of conduit.

**NOTE:** If cable is broken, it will be necessary to remove lower portions of cable from transmission end of conduit.

4. Lubricate cable with lubricant, then push cable into conduit. Connect upper end of cable to speedometer head and road test vehicle.

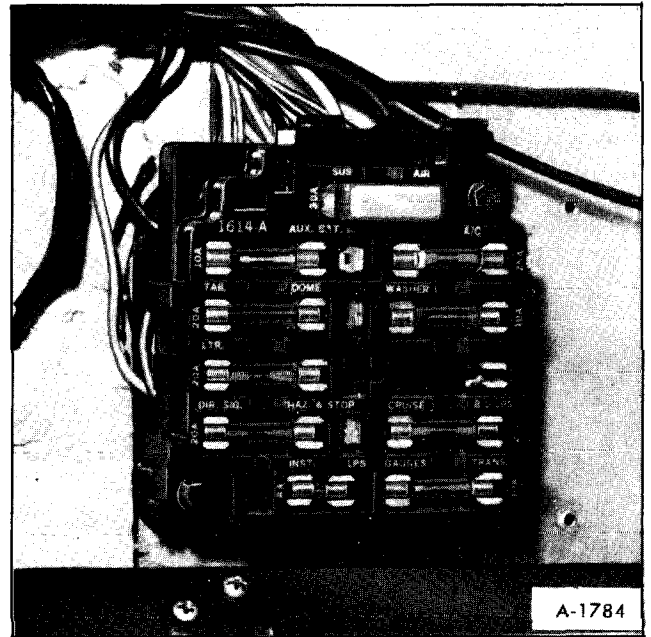

Figure 7-Fuse Panel

**NOTE:** Speedometer cable should be lubricated with AC Speedometer Cable lube ST-700 Part No. 6478535 or equivalent.

### FUSES AND FUSIBLE LINKS

The fuse panel, Figure 7, is mounted on the bulkhead panel behind the glove box assembly. To gain access to the fuse panel, open the glove box and depress the hooking tang which allows the glove box to be swung out of the way.

The following fuses are located in this panel: aux. battery switch, heater-A/C tail and dome lights, windshield washer, cigar lighter, directional and stop lights, cruise control, transmission control and gauges, instrument lamps, and tell-tale lights. The following circuits employ circuit breakers or have fuses located as indicated:

- Headlight circuit breaker — built into switch
- Heater blower — built into line at right access door near heater blower
- Warning & signal flasher — in clip behind instrument panel
- Vehicle trouble light — in line, behind access door near light
- Rr suspension compressor circuit breaker — in fuse block

A fusible link is placed in the horn power feed circuit and is designed to protect wiring from damage in case of shorts.

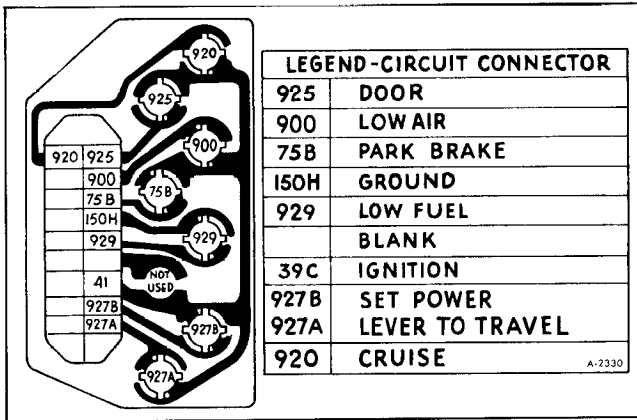

Figure 8-Tell-Tale Printed Circuit

## PRINTED CIRCUITS

Printed circuits are used on the tell-tale lamp assembly, the speedometer and the gauge cluster to provide current for operation and illumination.

### CHECKING CIRCUITS USING PRINTED CIRCUIT TELL-TALE LIGHT PANEL

Tell-tale printed circuit (figure 8) provides electrical contacts for illumination of various warning lights. Bulbs used in the tell-tale panel are listed in Specifications at the end of this section. To check the various tell-tale circuits proceed as follows:

a. Cruise control circuit (Refer to ENGINE & CHASSIS WIRING DIAGRAM).

1. Remove the instrument panel rear cover.
2. Remove the tell-tale light panel connector and remove the tell-tale panel.
3. With a continuity light, connect one probe of the test light to "41" of the printed circuit and the other probe to "920" with the cruise bulb in place. If the test light lights, the bulb and the circuit are good. If the test light does not light proceed to step 4.
4. If the test light does not light, remove the "920" bulb, "cruise" and check bulb, if bulb is good, problem is in the cruise tell-tale printed circuit board.

b. Door ajar.

1. With the tell-tale panel removed jump across the "925" and "41" terminals of the printed circuit with a self-powered test light.

2. If the test light lights, the circuit is good, if it does not proceed to step 3.

3. If the test light does not light, remove the

"DOOR" bulb and check, if good, problem is in the printed circuit board.

c. Low air.

1. Follow the same procedure as described under "DOOR AJAR" circuit but use terminals "900" and "41".

d. Park Brake 1. Follow the same procedure as described under "DOOR AJAR" circuit but use terminals "75B" and "41".

e. Low Fuel

1. With the tell-tale panel removed, connect the test light probes between "929" and "150H", if test light lights circuit is good, if it does not, follow the same procedures explained under "DOOR AJAR" tell-tale.

f. Set Power Lever To Travel

1. Follow the same procedure outlined for "DOOR AJAR" circuit but use both "927B" and "927A" to check for continuity to terminal "41".

### SPEEDOMETER CIRCUIT

The speedometer printed circuit shown in Figure 9 provides electrical paths for the hi-beam, turn indicator and illumination lamp. As can be seen from Figure 9 the "F" terminal of the circuit provides an illumination lamp and turn indicator lamp ground. In addition to the "F" terminal ground a separate L.H. side illumination lamp ground is provided through a printed circuit trace to the speedometer case. Illumination bulbs can be removed by turning them 1/4 turn and pulling out. They are accessible by removing the instrument panel lower access panel and reaching up to the speedometer head.

### GAUGE CLUSTER

The fuel, engine temperature and oil pressure gauges are located in the gauge cluster. Connection

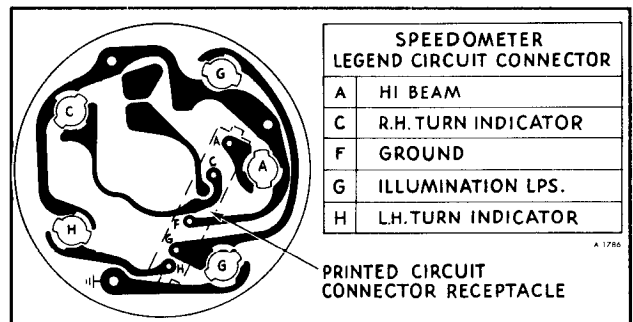

Figure 9-Speedometer Printed Circuit

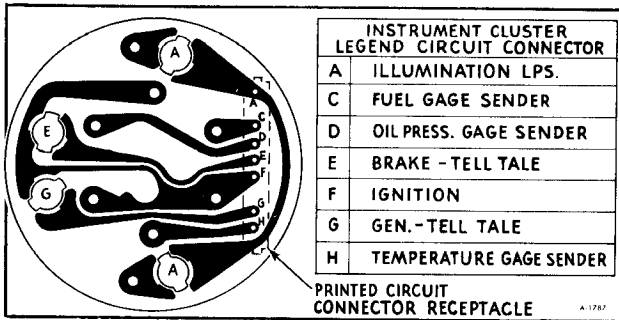

Figure 10—Gauge Cluster Printed Circuit

is made to this gauge by a (7) pin connector which feeds a printed circuit shown in Figure 10.

## FUEL GAUGE

When checking the fuel gauge circuit, first determine whether the tank unit, wiring, or fuel gauge is faulty.

To check fuel gauge wiring, refer to Figure 19 for appropriate wiring harness connections. Connection at the gauge head is made through a printed circuit located at the rear of the gauge head. The fuel tank selector switch is located between the fuel gauge and the fuel sending units in the tanks. The fuel selector switch position determines which tank level is being measured.

**CAUTION:** *When checking fuel tank gauge wiring, never apply 12-volt current directly to the fuel tank float unit body feed wire as this will destroy the units' resistive element.*

The fuel gauge shows the approximate fuel level in the main tank when fuel selector switch is in the "FUEL MAIN" position, and the fuel level in the auxiliary tank when fuel selector switch is in the "FUEL AUX" position. The pointer will indicate the correct levels, only when the ignition is in the "ON" position. Since both fuel tanks are interconnected the gauge is designed to read the same (with the switch in either position) until approximately 60% of the total fuel capacity has been used.

If a condition is present where the vehicle is run in the "MAIN" position and allowed to deplete fuel supply on gauge, then switching to "AUX" does not provide the reserve 7 to 9 gallon amount, it is possible the wiring connector near the frame rail and tanks has the wires crossed in connection. The wires in this connection should be color to color from each side of the connector. This condition can also be detected by running in "AUX" position, switching to "MAIN" provides gauge reading of greater amount.

Changing the fuel selector switch position changes the fuel pick-up and fuel gauge sending unit from the main tank, as it goes empty, to the auxiliary tank, which will contain approximately 7 to 9 gallons of fuel.

## FUEL GAUGE SYSTEM DIAGNOSIS

The following checks of the fuel indicator system will determine quickly whether incorrect fuel gauge readings are the result of an improperly operating fuel gauge, fuel tank sending unit or circuit wires. Refer to Figures 11 and 12 and also "Fuel Gauge Diagnosis Details" for fuel gauge system diagnosis.

### GAUGE DIAGNOSIS DETAILS

#### ERRATIC FUEL GAUGE READINGS

Inspect all circuit wiring for damage to insulation or wire, also carefully check for proper electrical connection at the following locations:

1. Terminal connections at two-way connector to tanks.
2. Ground connection—one-way connector from tank to ground.
3. Body harness connector—10-way connector at instrument panel.
4. Body harness connector to printed circuit at gauge.
5. Mounting screws holding gauge to panel.
6. Make sure gauge pointer is not contacting face of gauge or lens.
7. Fuel selector switch connections.

#### GAUGE ALWAYS REGISTERS FULL (WITH IGNITION SWITCH ON)

Most probable cause is an open circuit in wiring or tank unit.

1. Check ground wires from tank units to ground. If loose, clean terminals, reinstall and check gauge reading.
2. Connect a spare tank unit to tank wiring. Raise and lower the float arm slowly, observing the dash unit (Be sure selector switch is in the appropriate position).

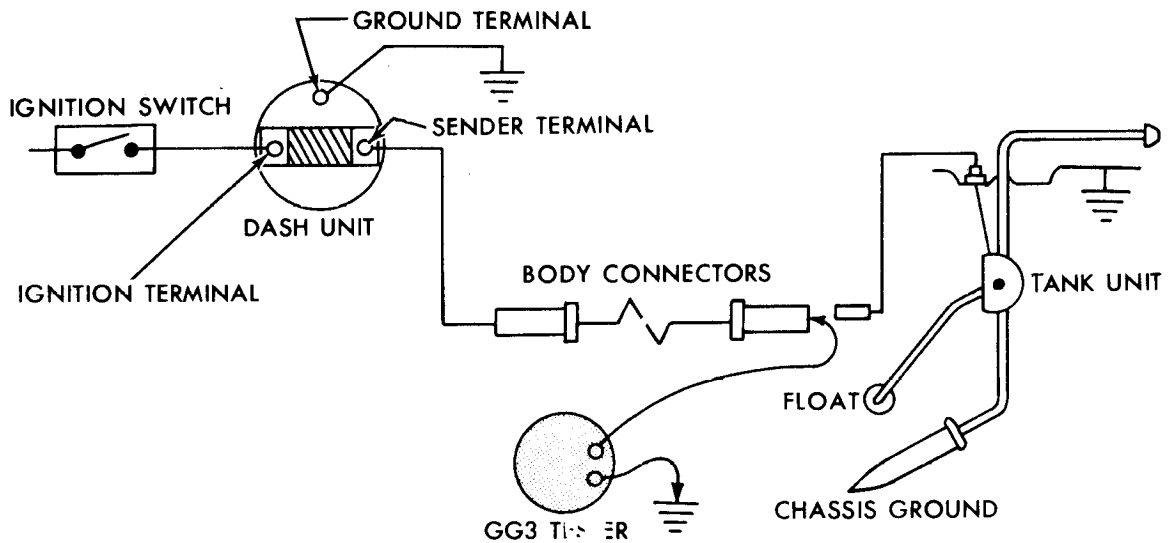

With vehicle on level surface, disconnect rear wiring connector and attach AC-GG3 tester between wire to dash unit and chassis ground.

Position ignition switch in "ON." DO NOT START ENGINE.

1. With tester knob set at "continuity" lamp should glow.
2. With tester knob set at "0" dash unit should indicate "EMPTY."
3. With tester knob set at "90" dash unit should indicate "FULL."

4. If 1, 2, and 3 above are OK, inspect tank unit ground and wire to tank unit. Repair as necessary to insure good electrical connections and no shorts throughout.

5. If fuel gauge system is still not functioning properly after completing Step 4, replace tank unit.

6. If any one of 1, 2, or 3 are not OK, inspect wiring from ignition switch to the rear wiring connector (including grounds). Repair as necessary to insure good electrical connections and no shorts throughout.

7. If any one of 1, 2, or 3 are still not OK after completing Step 6, replace dash unit.

Figure 11—Fuel Gauge Switch Diagnosis (Method Using AC-GG3 Tester)

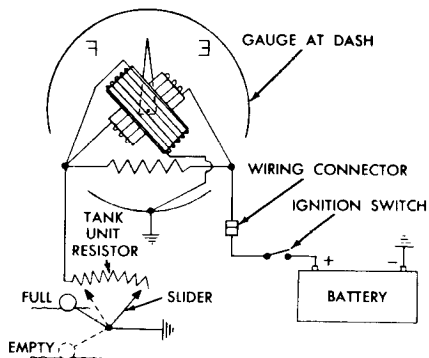

**POSSIBLE COMPLAINT**

Reads 1/4 when empty or won't read empty	Reads accurately above 1/4	Needle does not move	Reads "E" all the time	Reads "F" all the time	Reads 3/4 when full	Reads 1/4 when full or won't read full	Erratic reading
--	----------------------------	----------------------	------------------------	------------------------	---------------------	--	-----------------

**PROBABLE CAUSE**

**SUGGESTED REMEDIES**

PROBABLE CAUSE	Reads 1/4 when empty or won't read empty	Reads accurately above 1/4	Needle does not move	Reads "E" all the time	Reads "F" all the time	Reads 3/4 when full	Reads 1/4 when full or won't read full	SUGGESTED REMEDIES
1. Loose connection anywhere in circuit							x	Inspect and, if necessary, clean and tighten all connections in circuit
2. Poor dash fuel gauge calibration							x	Install new dash fuel gauge
3. Poor tank unit calibration							x	Install new tank unit*
4. Circuit grounded in resistor of tank unit					x	x		Install new tank unit*
5. Circuit grounded between tank unit resistor and dash gauge			x					Insulate grounded circuit
6. Circuit within dash gauge grounded.							x	Install new dash fuel gauge
7. Circuit grounded between battery and dash gauge.		x						Insulate grounded circuit
8. Open circuit between ignition switch and dash gauge		x						Clean and tighten appropriate terminals or repair broken wire
9. Open circuit between ground terminal on gauge and ground			x					Clean and tighten mounting bracket where contact is made between dash gauge and ground
10. Open circuit between sending unit terminal on dash gauge and resistor terminal on tank unit				x				Clean and tighten appropriate terminals or repair broken wire
11. Open circuit in resistor of tank unit at 1/4 full position	x							Install new tank unit*
12. Open circuit between tank unit slider resistor and ground				x				Install new tank unit*
13. Needle rubbing on face of gauge			x	x	x	x	x	Position needle to prevent contact with face or install new gauge
14. Fuel tank float hang-up	x		x	x	x	x	x	Free binding float or install new tank unit*
15. Top of fuel tank deformed					x			Straighten tank top or replace tank
16. Bottom of fuel tank deformed	x							Straighten bottom of tank or replace tank
17. Tank unit mounting flange bent	x				x	x		Straighten mounting flange or replace tank unit*

\* Ignition switch must be "OFF" before removing tank sending unit, otherwise full battery voltage may destroy unit or ignite fuel vapors. For maximum safety, remove cable from negative battery terminal. A-1790

Figure 12-Fuel Gauge System Diagnosis

a. If dash unit does not function an open circuit at dash or tank unit is indicated.

b. If dash unit follows the arm movement proceed to step 3.

3. Inspect the wire terminals at the tank unit after lowering the fuel tank. If connection is loose, clean terminals and reinstall wires. If gauge continues to register "FULL" (with tank empty), remove the tank unit. Reconnect the wiring with unit out of tank, including the ground and move float arm. If dash unit does not follow arm movement, replace the tank unit.

### **GAUGE ALWAYS REGISTER EMPTY (WITH IGNITION SWITCH ON)**

Most probable cause is a grounded circuit in the wiring due to a pinched or cut wire, or shorted fuel gauge dash unit. Disconnect the tank unit feed wire at the tank. The dash unit gauge should now register FULL.

#### **Gauge Continues To Read Empty**

1. Remove the instrument panel rear cover.
2. Remove the fuel gauge wire from the 7-wire connector on the gauge head (GRAY/DBL BLACK STR).
3. Gauge should now read FULL. If the gauge continues to read EMPTY, replace the dash unit.

#### **Gauge Now Registers Full**

1. Connect a spare tank unit to the tank feed wire at the body harness connector and ground unit at flange to chassis with a jumper wire.
2. Raise and lower float arm assembly while observing the dash unit.
  - a. If dash unit still does not operate, replace the dash unit after a continuity check of printed circuit has been made.
  - b. If the dash gauge follows the float arm movement, check tank unit feed wire for insulation breakdown. If wire is okay, replace the tank unit.
3. Check tank unit for improper installation of fuel filter screen which could restrict float movement.
4. If dash unit still does not follow the tank unit arm movement, replace the tank unit.

## **WATER TEMPERATURE GAUGE**

When checking the water temperature gauge circuit, determine whether engine temperature sending unit, wiring, dash unit or printed circuit is faulty.

To check the engine water temperature sending unit, proceed as follows:

1. Disconnect wire at engine unit.
2. Connect a test light consisting of a 12V-2 candle power bulb and a pair of test leads in circuit by clipping one lead to battery positive terminal and other lead to body of engine gauge unit. If bulb lights, unit is properly grounded. If bulb does not light, check for presence of sealing compound around threads of unit. Remove compound and repeat test.
3. Remove test lead from body of unit and connect lead to terminal of unit. If bulb lights, engine unit is internally shorted and should be replaced.
4. Remove test light and reinstall wire on terminal.
5. If engine unit tests satisfactory under previous conditions, check the following items according to nature of difficulty:
  - a. If gauge does not register with ignition on: this may be caused by a break in the circuit between the gauge and the switch through the printed circuit or a short between the connector lead and the ground (See figure 10).
6. If gauge shows high temperature under all conditions, wire leading from gauge to engine unit is shorted to ground.
7. If gauge registers a low temperature reading under all conditions, wire between gauge and engine unit is broken.
8. Dash unit replacement should be made after the previous checks have been made for trouble source.

Do not attempt to repair either the engine unit or the gauge. When installing new engine unit, do not use thread compound on unit threads, as this will increase electrical resistance of unit and cause faulty reading on gauge.

## **OIL PRESSURE GAUGE**

An electric oil pressure gauge is used on all vehi-



cles covered in this manual. A variable resistance sending unit is connected to an engine oil pressure gallery to vary the amount of resistance to ground with changes in engine oil pressure. Current is fed through the printed circuit on the back of the gauge (figure 10) from the wiring harness.

The oil pressure gauge can be checked for cause of difficulty using the following procedure:

1. Connect test lamp of not more than 2 candle power between battery positive terminal and the body of the sending unit. If lamp fails to light, the unit is not grounded, the threaded hole and threads on the unit should be checked for metal-to-metal contact. If the lamp lights the unit can be considered properly grounded. When replacing sending unit do not use compound on threads.

2. Remove the wire from the unit terminal and connect the test lamp between the unit terminal and the battery positive terminal. If the lamp lights, start engine and observe if the lamp changes intensity. A satisfactory unit will change the lamp intensity with changes in engine oil pressure. (DO NOT USE A LAMP OF OVER 2 candle power).

3. Connect the wire and check wiring for open circuit between unit and connector at the back of gauge head.

4. Check for continuity in printed circuit trace.

5. If no defective wiring or connections exist and sending unit checks out satisfactory, replace dash unit.

**NOTE:** No attempt should be made to repair either the gauge or the sending unit.

6. Refer to Figure 13 for further gauge diagnosis information.

## LOW-FUEL INDICATOR CIRCUIT

The optional low fuel tell-tale indicator used on vehicles covered by this manual is activated by a voltage sensitive switch. As the fuel tank float changes position, a change in the tank unit circuit voltage is sensed by the low fuel switch. At a predetermined value, the switch will turn the low fuel light on, alerting the operator of the low fuel level. The low fuel switch is replaced from the rear of the instrument panel and is connected to the wiring harness through a 4 wire connector. Low fuel switch wiring is shown in Figure 14.

The low fuel switch can be checked for satisfactory operation by using the following procedure:

1. Locate the fuel tank unit feed wire and connect to ground.

2. Turn ignition switch to "ON".

3. Fuel gauge should read "EMPTY" and "low fuel" light in the tell-tale panel should be on. A low fuel condition is considered at approximately 1/16 to 1/8 tank level.

4. If light does not come on, check tell-tale bulb and replace if necessary.

5. If light still does not come on, check fuse panel (figure 7) for possible blown fuse at the "GAUGES" location.

6. Check switch wiring to fuel selector switch and to ground, if wiring is satisfactory and light still does not light, replace low fuel switch.

If low fuel indicator light remains on at all times when tank level is above the 1/16 to 1/8 level, replace the low fuel switch.

## MISCELLANEOUS

### DOMELIGHT SWITCH

The dome light switch, located on the speaker-dome light panel is a three position switch with the following functions:

1. Lamp operation (for that particular side) controlled by the headlight switch.

2. Lamp off, regardless of headlight switch position.

3. Lamp on, regardless of headlight switch position.

#### Switch Replacement

1. Disconnect the battery ground cables.

2. Remove the (4) dome light panel retaining screws.

3. Remove the (2) switch retaining screws.

4. Disconnect the dome lamp switch harness connector.

5. Remove the dome light switch.

6. To install, reverse steps 1-5 and check operation.

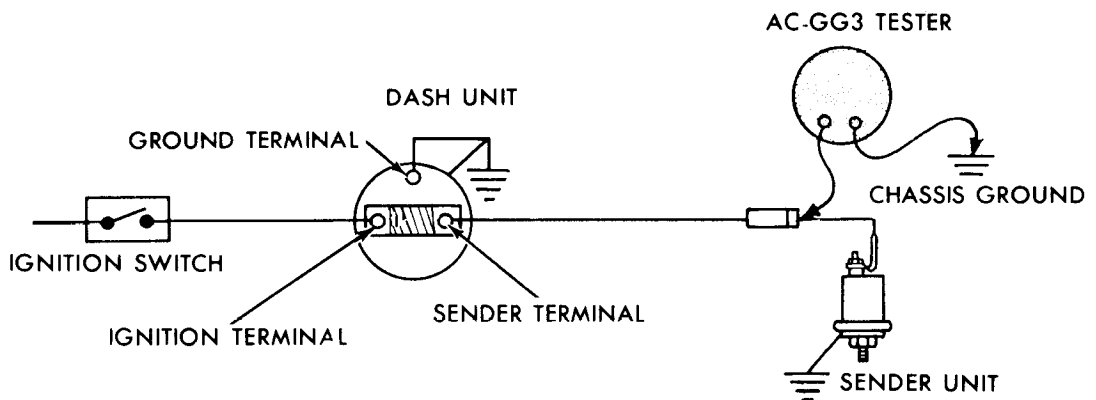

Disconnect wire from sender unit and attach AC-GG3 tester between this wire and chassis ground.

Position ignition switch to "ON." DO NOT START ENGINE.

1. With tester knob set at "Continuity," lamp should glow.
2. With tester knob set at "0," dash unit should indicate "0" psi.
3. With tester knob set at "90," dash unit should indicate "full scale" pressure.

4. If 1, 2, and 3 above are OK, clean sender terminal to insure good electrical contact with wire and make sure sender unit is grounding to engine.

5. If pressure gauge system is still not functioning properly after completing Step 4, replace sender unit.

6. If any one of 1, 2, and 3 are not OK, check wiring and all connections (including grounds).

7. If any one of 1, 2, and 3 are still not OK after completing Step 6, replace dash unit.

A-1791

Figure 13—Engine Oil Pressure Gauge Diagnosis (Method Using AC-GG3 Tester)

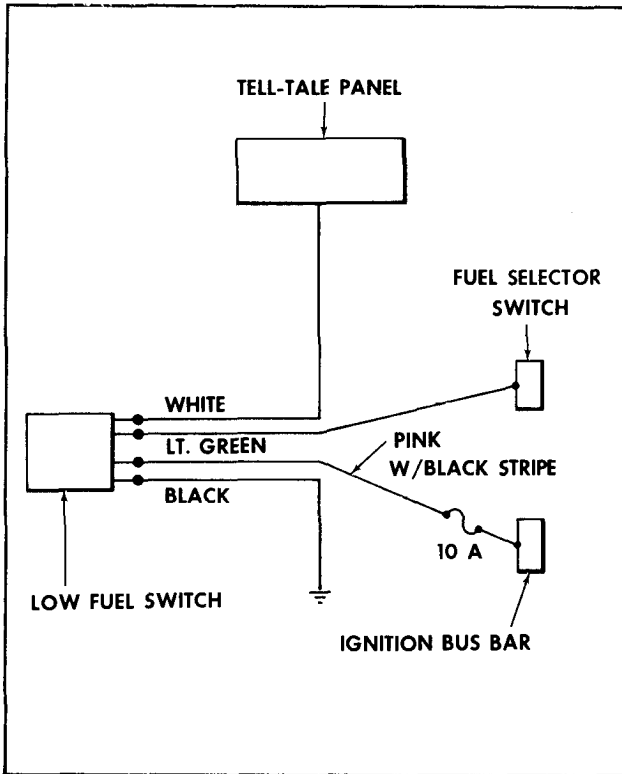

Figure 14—Low-Fuel Indicator Switch Circuit

## WINDSHIELD WASHER SWITCH

The windshield washer switch is a spring loaded switch which returns to the off position when the

toggle is released. This switch supplies power to the windshield washer pump for pumping of washer solvent onto the windshield.

### Switch Replacement

1. With a flat blade screwdriver engage the switch ring with the screwdriver blade while holding the back side of the switch (See figure 2).
2. Remove the retaining ring from the switch and bring the switch down to a more accessible position.
3. Disconnect the wiring harness connector from the switch.
4. Remove the switch from the panel.
5. To install, reverse steps 1–4, and check operation.

## IGNITION SWITCH

The ignition switch is mounted on the right-side of the steering column. In addition to the steering column and shift lever lock feature, when the entrance door is open a buzzer located behind the left-hand engine access door would remind the driver to remove the key from the ignition switch. Replacement procedures for the ignition switch are covered in STEERING (SECTION 9) of this manual.

# WIRING

## GENERAL MAINTENANCE

Loose or corroded connections may cause a discharged battery in addition to difficult starting, dim lights and possible generator or regulator damage. A periodic check for clean and tight connections is important for dependable electrical system operation.

Wires and/or harnesses must be replaced if insulation becomes burned, cracked or deteriorated. Whenever it is necessary to splice a wire or repair one that is broken, always use rosin flux solder to join the wires and insulating tape to cover the splice on bare wires. Circuit tests for continuity can be made by referring to ENGINE AND CHASSIS WIRING DIAGRAM.

When replacing wire, it is important that the correct gauge be used.

**NOTE:** Never replace a wire with one of a smaller size. Fusible links in the wiring are four gauge sizes smaller than the wire it is designed to protect.

Fusible links are marked on the insulation with wire gauge size because of the heavy insulation which makes the link appear a heavier gauge than it actually is.

Each harness and wire must be held securely in place by clips or other holding devices to prevent chafing or wearing away the insulation due to vibration.

By referring to the wiring diagram, circuits may be tested for continuity or shorts with a conventional test lamp or voltmeter.

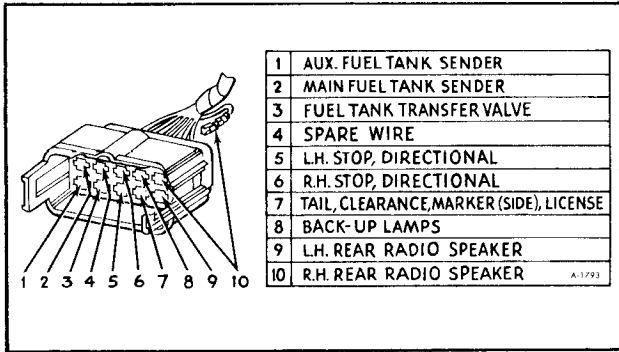

Figure 15—Left-Side Body Wiring Connector

### LEFT-SIDE BODY WIRING

Wiring for rear lighting, fuel tanks and rear speakers passes through a (10) way multiple connector located in the front L.H. corner of the instrument panel. Rear lighting circuits can be checked for continuity through the female portion of this connector. Figure 15 shows the (10) way multiple connector and the appropriate wire position in the connector body. Refer to the vehicle wiring diagram for wire size and code used in the rear end wiring.

### FRONT WIRING

Dome lights, headlamps and front clearance lights are fed through an (8) way multiple connector located under the instrument panel. The front lighting wiring is part of the instrument panel wiring harness. Figure 16 shows the female portion of the front lighting harness and the appropriate wire position in the connector body.

Front wiring for front clearance, identification, dome lamps and front speakers is shown in Figure 17. Door jamb switch wiring is found on the right hand side of the vehicle and is shown in Figure 18.

### INSTRUMENT PANEL WIRING

Wiring to the instrument panel is made through multiple terminal connectors at the tell-tale panel, speedometer, headlight switch and cluster gauge.

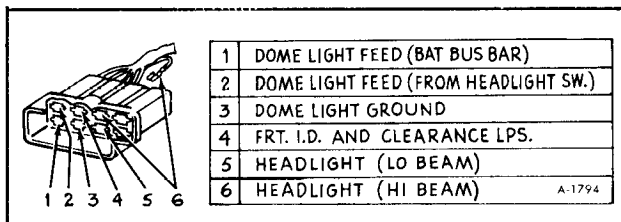

Figure 16—Front Wiring Connector

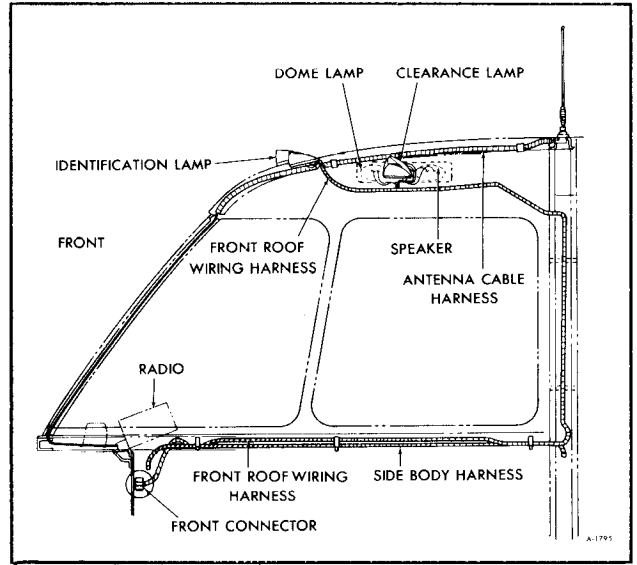

Figure 17—Front Wiring (Roof)

Figure 19, instrument panel, shows instrument wiring and proper connector location.

Radio wiring for AM and AM-FM Mono models is shown in Figure 20. Refer to ENGINE AND CHASSIS WIRING DIAGRAM for wire size and color application for instrument panel wiring.

### STEERING COLUMN WIRING

Connections for directional signals, ignition switch, neutral safety switch, back-up lamps and

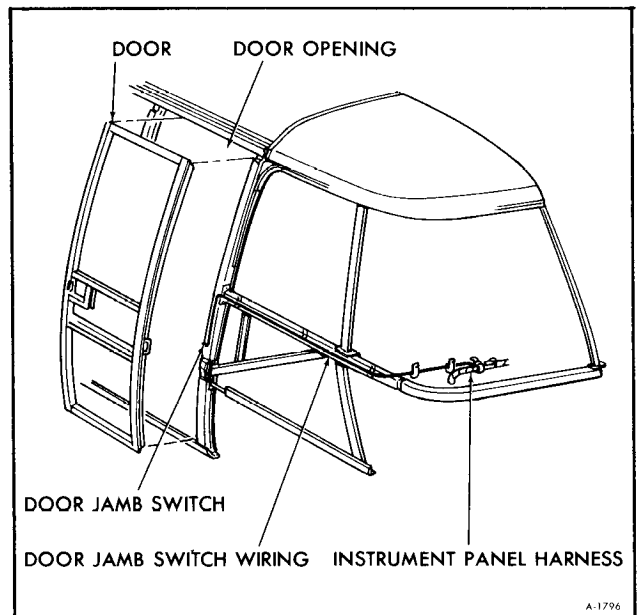

Figure 18—Door Jamb Switch Wiring (Model 230 Shown)

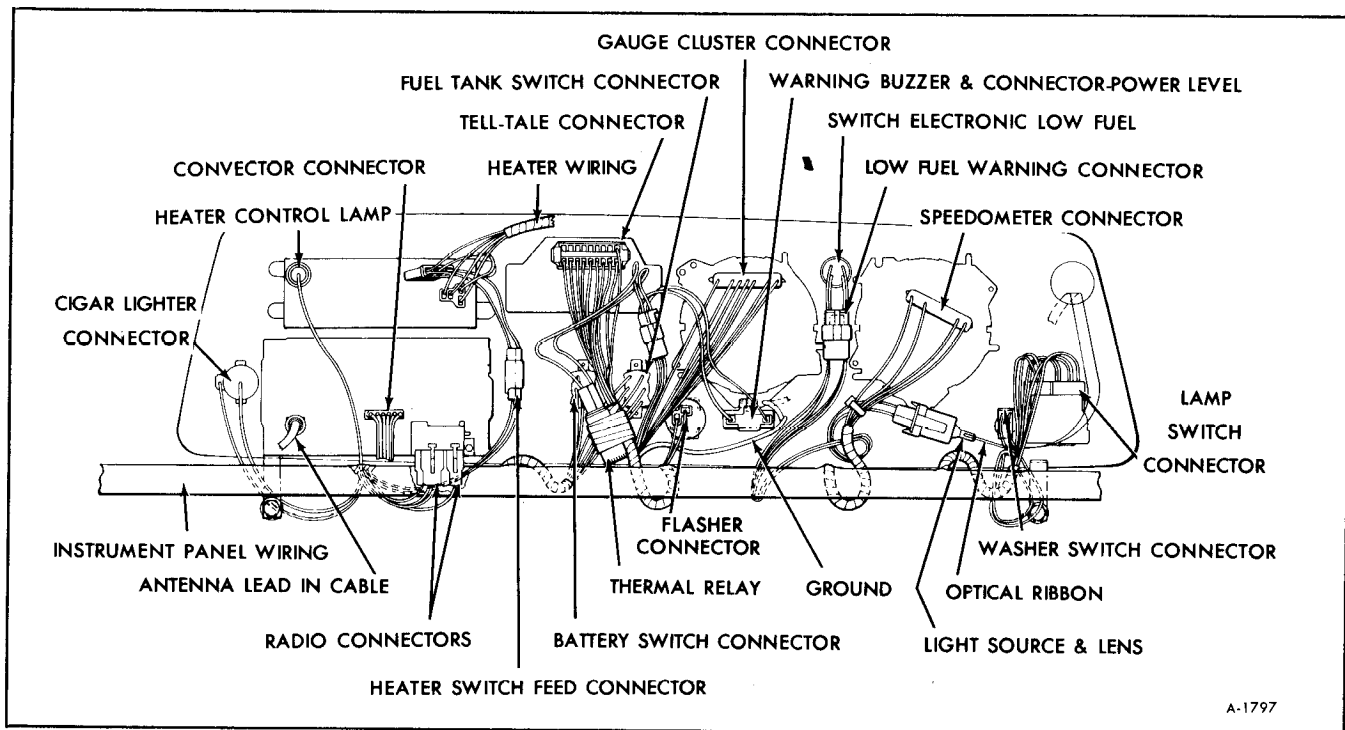

Figure 19-Instrument Panel Wiring

power leveler warning are shown in Figure 21. These connectors are located on the steering column. Refer to vehicle wiring diagram for applicable wire size and color.

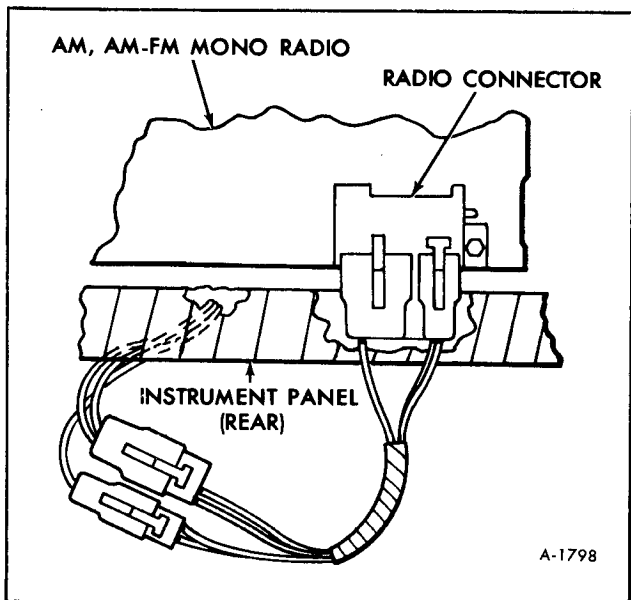

Figure 20-AM, AM-FM Mono Radio Connector

## REAR BODY WIRING

Wiring for rear identification and clearance lamps along with rear speakers is fed around the rear of the body through a plastic loom. This harness is connected to the side body through a 6-way multiple connector located in the L.H. rear corner of the vehicle (See figure 22). Refer to ENGINE AND CHASSIS WIRING DIAGRAM for applicable wire size and color code.

## TRAILER WIRING

The optional trailer wiring is installed as shown in Figure 23. This connection is made between the L.H. side body harness and the rear body harness at the L.H. rear corner of the vehicle.

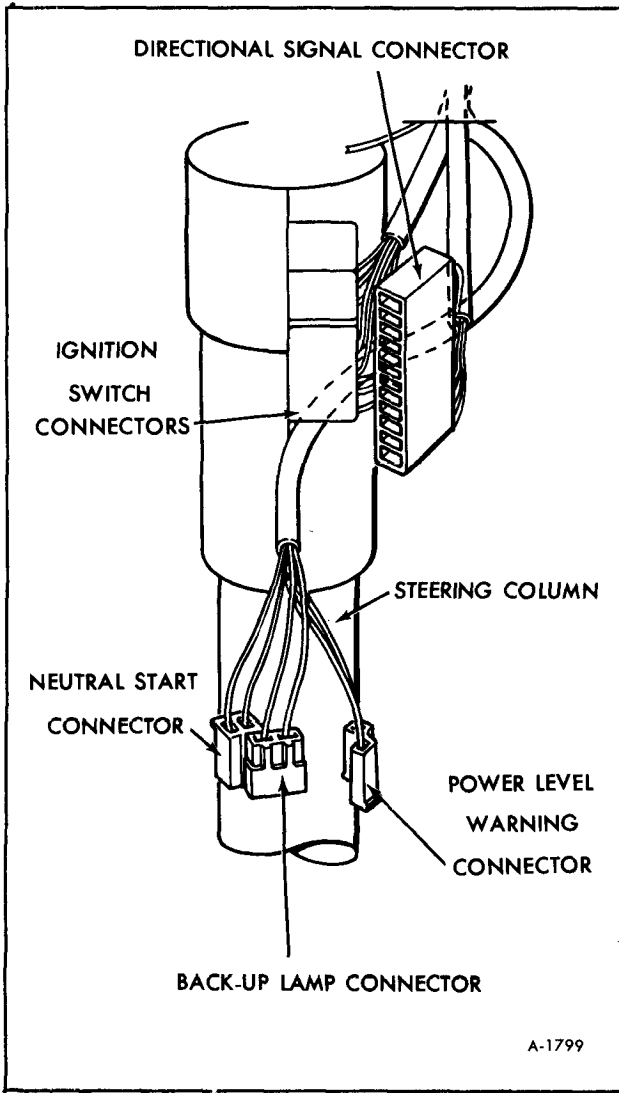

Figure 21-Steering Column Wiring

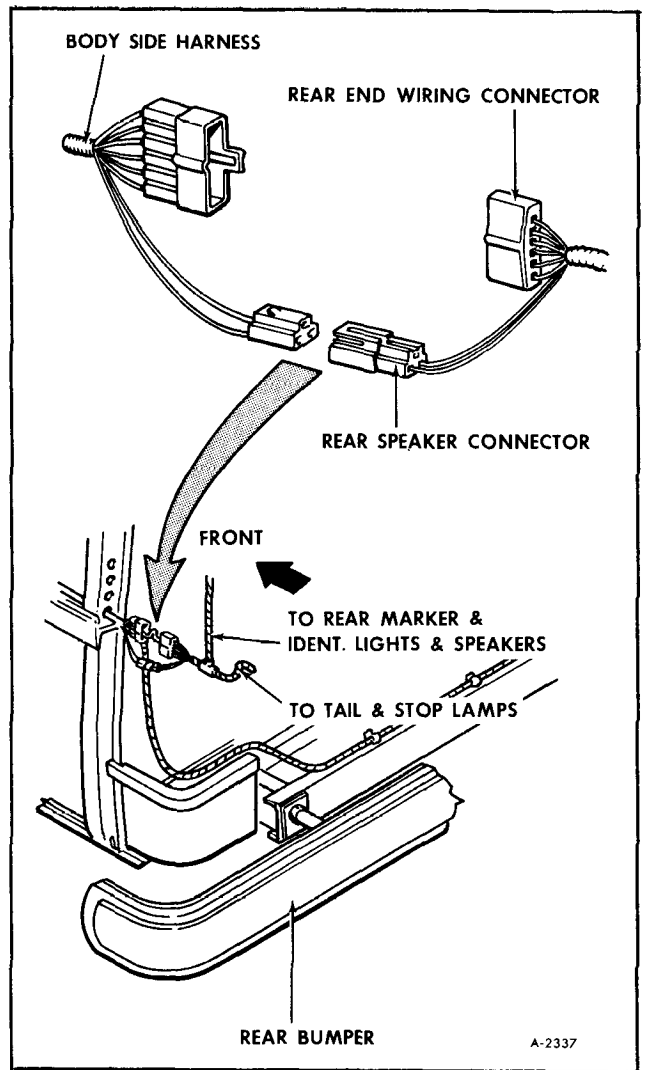

Figure 22-Rear Body Wiring

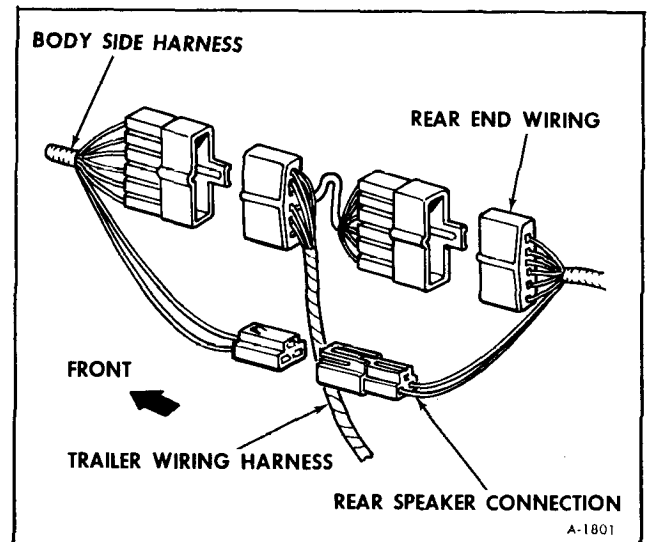

Figure 23-Trailer Wiring

# LIGHTING SYSTEM

## GENERAL INFORMATION

The lighting system includes the main light switch, stop light switch, dimmer and back-up lamp switches, head and parking lamps, stop, tail, side marker, clearance and identification lamps, porch light; instrument illumination, directional signal and indicator lamps and necessary wiring to complete the various circuits.

All Motor Home models use a single 7-inch single sealed-beam unit type headlight, all other lights are a replaceable bulb type. Refer to "Light Bulb Specifications" at the end of this section for bulb number.

## HEADLAMP ADJUSTMENT

The headlamps must be properly aimed to obtain maximum road illumination. Proper aiming should be checked whenever a sealed beam unit is replaced or after any repair of the headlamp socket assembly. Regardless of the method used for checking headlamp aim, the vehicle must be at normal ride height, that is with gas, water and passenger weight most frequently traveled with.

**NOTE:** Some states have special headlamp aiming requirements which must be known and followed.

Horizontal and vertical aiming of each sealed beam is provided by two adjusting screws which move the mounting ring against the retaining spring tension (figure 24).

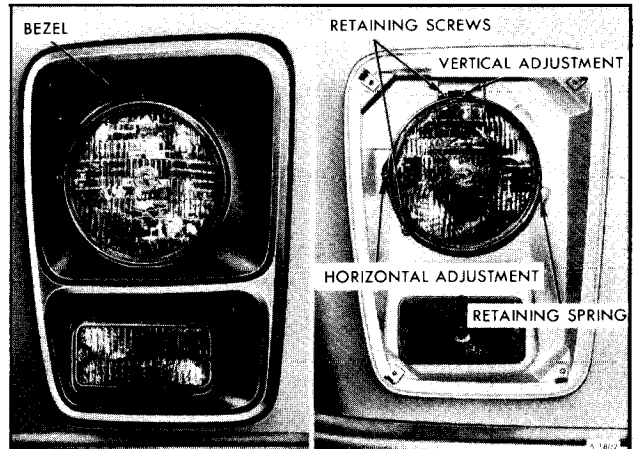

Figure 24—Headlamp Adjustment

## HEADLAMP REPLACEMENT (FIGURE 25)

1. Remove (4) headlamp bezel retaining screws.
2. Disengage spring from retaining ring.
3. Turn headlamp unit to disengage assembly from headlamp adjusting screws.
4. Disconnect wiring harness connector located at the rear of the sealed beam assembly.

**NOTE:** Do not disturb adjusting screw setting.

5. Remove retaining ring and headlamp from mounting ring.

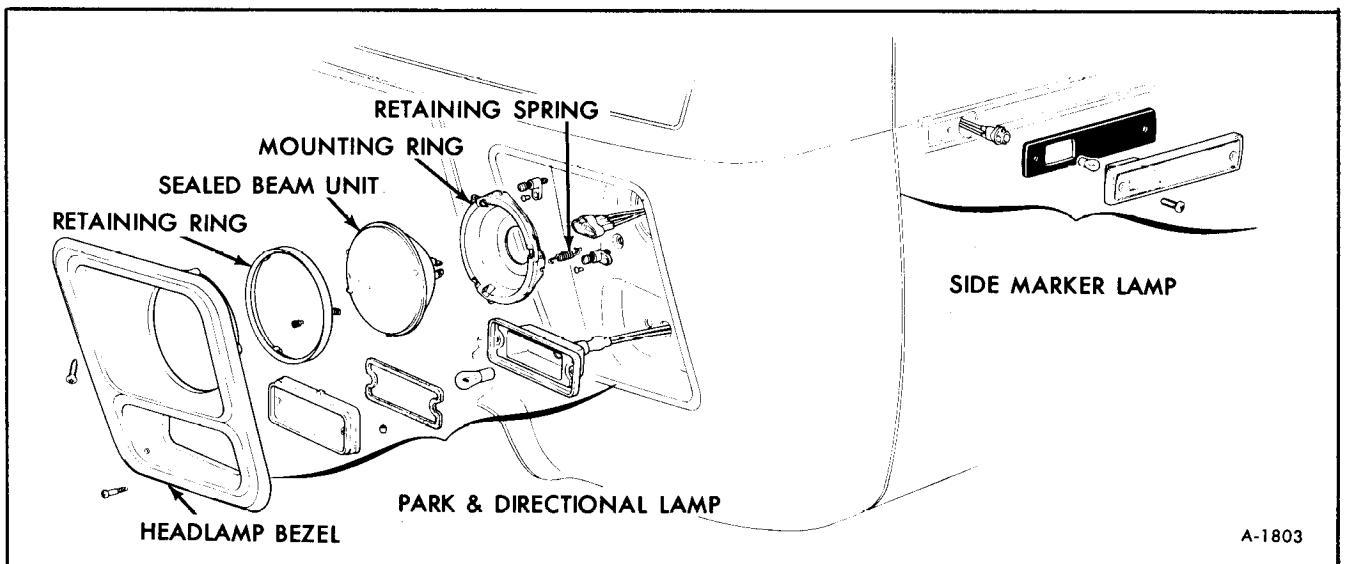
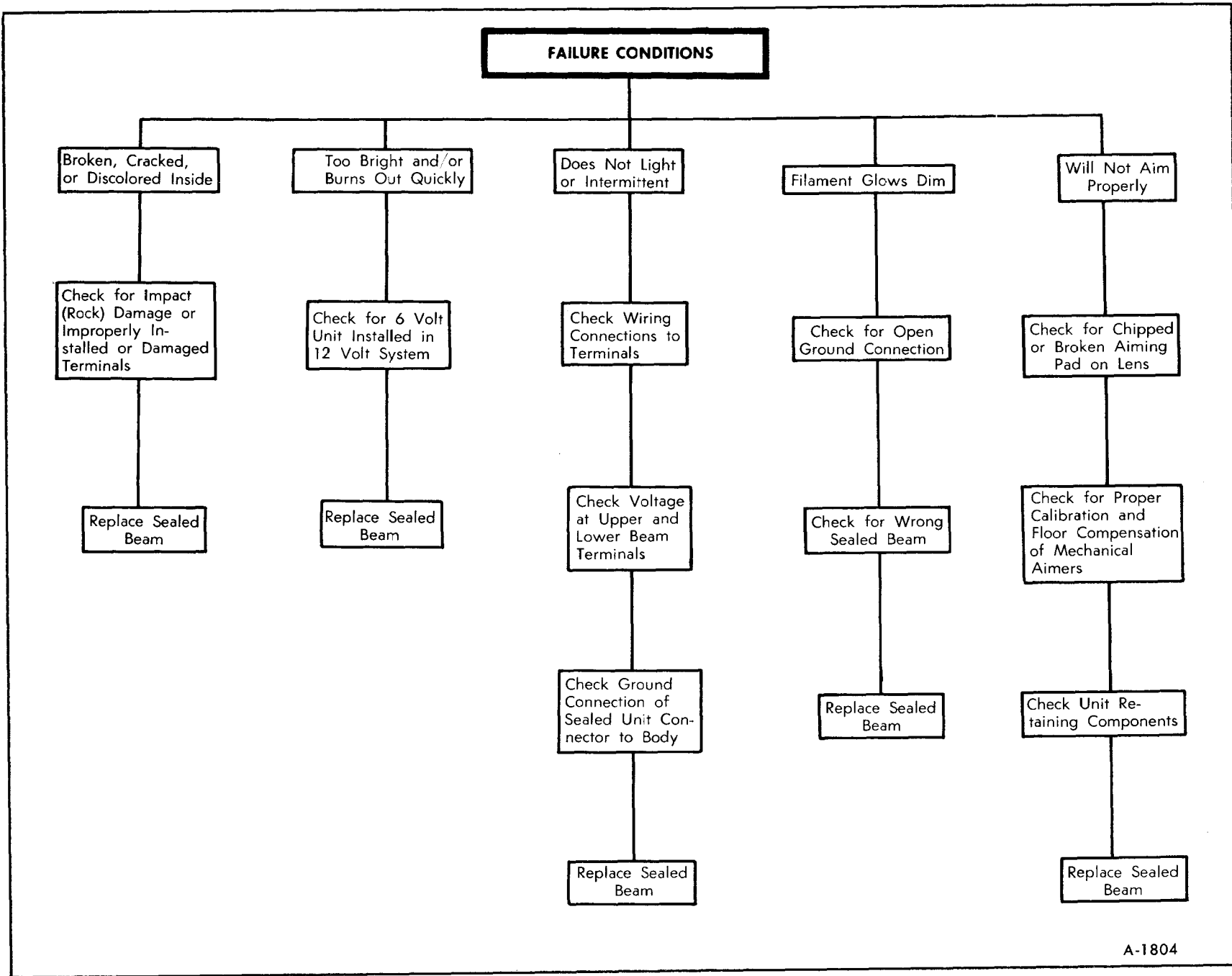

Figure 25—Headlamp and Side Marker Lamp Installation



A-1804

Figure 26-Headlamp Diagnosis



6. Position new sealed beam unit in mounting ring and install retaining ring.

**NOTE:** The number molded into lens face must be at the top of the bulb.

7. Attach wiring harness connector to unit.

8. Install headlamp assembly in panel opening, turning slightly to engage mounting ring tabs with adjusting screws.

9. Install headlamp retaining ring spring and check lamp aiming if adjusting screws have been turned.

10. Install headlight bezel with the (4) retaining screws.

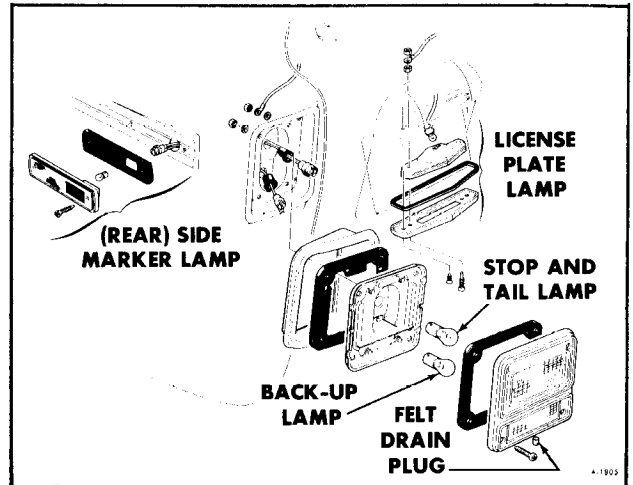

Figure 27—Tail, Stop, License and Rear Side Marker Lamps

## HEADLAMP DIAGNOSIS

For details on headlamp diagnosis, refer to Figure 26. Additional diagnosis information is covered later in this section under “Headlight Switch”.

## COMPONENT REPLACEMENT

### PARKING AND DIRECTIONAL SIGNAL BULB (FRONT) REPLACEMENT (FIGURE 25)

1. Remove (2) lens retaining screws and remove lens from housing.

2. Replace bulb and check operation. See Specifications at the end of this section for bulb No.

3. Install lens and retaining screws.

### SIDE MARKER LAMP BULB (FRONT AND REAR) REPLACEMENT (FIGURE 25 AND 27)

1. Remove (2) marker lamp retaining screws and remove lens.

2. Replace bulb and check operation. See Specifications at the end of this section for bulb No.

3. Install lens and retaining screws.

### TAIL, STOP, BACK-UP AND DIRECTIONAL SIGNAL BULB REPLACEMENT (FIGURE 27)

1. Remove (4) lens retaining screws and remove defective bulb.

2. Replace bulb and check operation. See Specifications at the end of this section for bulb No.

3. Install lens and retaining screws.

**NOTE:** Check for proper positioning of lamp assembly felt drain plug (See figure 27).

### LICENSE PLATE BULB REPLACEMENT (FIGURE 27)

1. Remove (2) outermost screws in license lamp lens.

2. Replace bulb and check operation by turning parking lamp on. See chart for bulb No.

3. Install lens with the (2) retaining screws.

### CLEARANCE AND IDENTIFICATION BULB (FRONT AND REAR) REPLACEMENT (FIGURE 28)

1. Remove lens, retaining screw, and then remove lens.

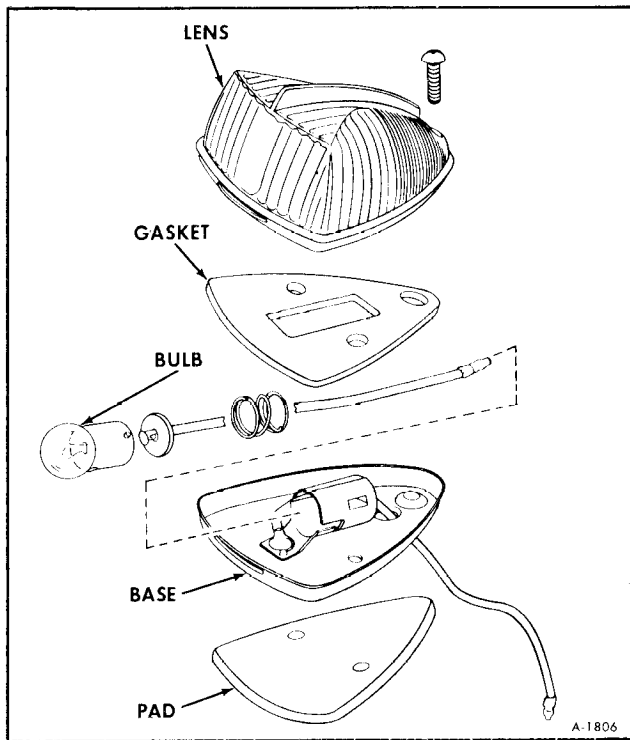

Figure 28—Clearance and Identification Lamp

2. Replace bulb and check operation. See Specifications at end of this section for bulb No.
3. Install lens and retaining screw.

### DOMELAMP BULB REPLACEMENT (FIGURE 29)

1. Remove dome lamp lens by gently prying with flat blade screwdriver between lens and housing.
2. Replace bulb and check operation. See chart for bulb No. at the end of this section.
3. Snap dome lamp lens back into position by pushing lens as far as possible in housing, locking tabs will hold the lens in place.

### ENGINE COMPARTMENT LAMP BULB REPLACEMENT

1. Remove the (2) lens retaining screws and then remove lens.
2. Replace bulb and check operation.
3. Install lens and retaining screws.

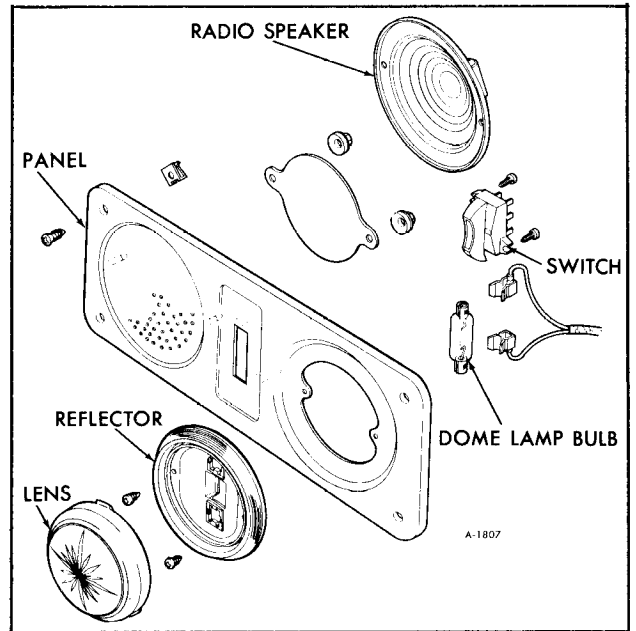

Figure 29—Dome Lamp Installation

### FIBER OPTIC RIBBON

Lighting for windshield wiper control, main light switch and washer switch is transmitted through a fiber optic ribbon from a main source bulb located on the L.H. side of the lower instrument panel cover. The ribbon should remain with the instrument panel bezel when the bezel is removed. The source bulb housing can be separated from the wiring harness to free the optic ribbon and permit bezel removal (See figure 30). Bulb number is listed in "Specifications" at the end of this section.



Figure 30—Fiber Optic Ribbon

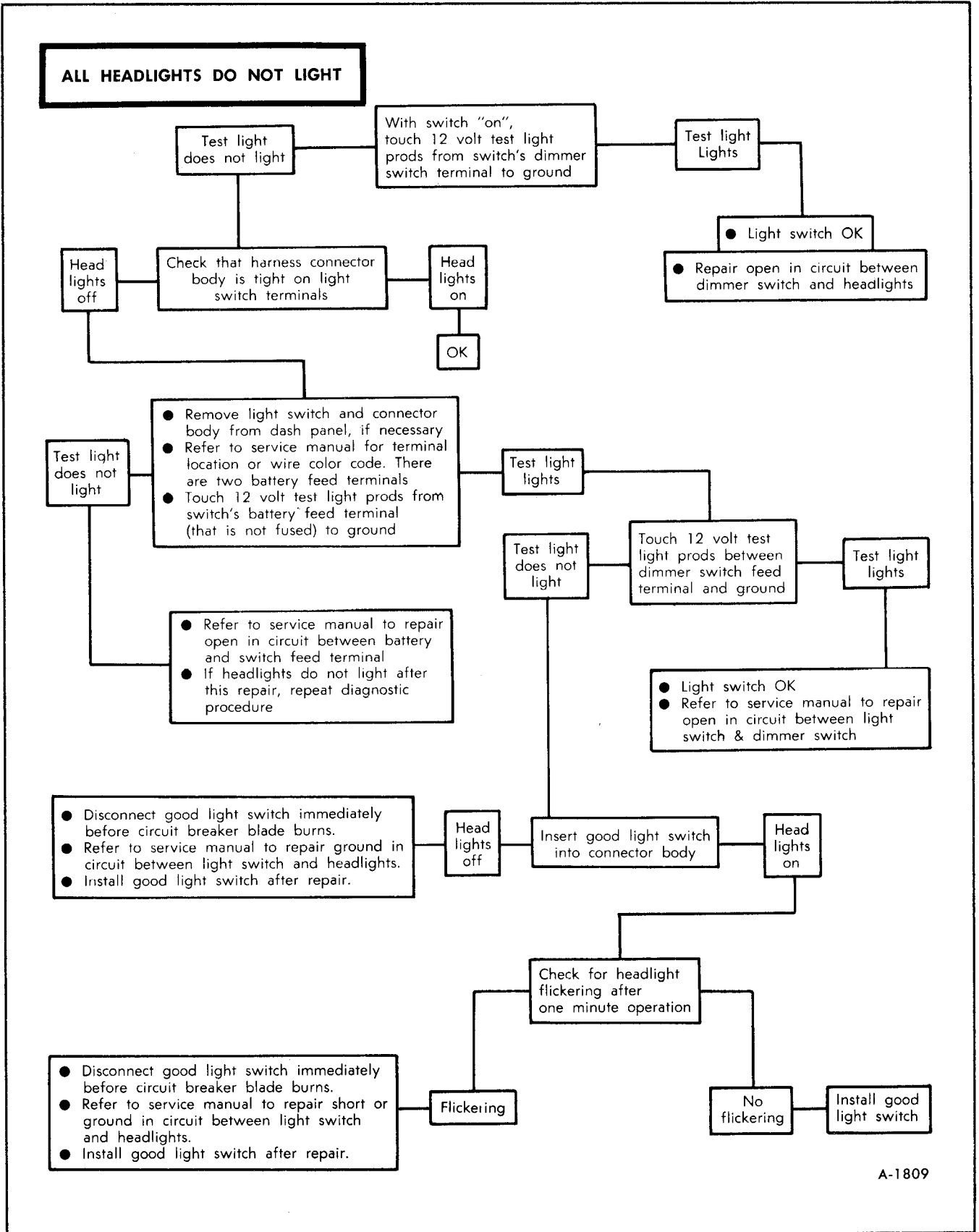

Figure 31-Headlight Switch Diagnosis

<b>ONE HEADLIGHT INOPERATIVE OR INTERMITTENT</b>	
POSSIBLE CAUSE	CORRECTION
Loose Connection	Secure Connections to Sealed Beam Including Ground (Black Wire)
Defective Sealed Beam	Replace
<b>ONE OR MORE HEADLIGHTS ARE DIM</b>	
Open Gr. Connection at Headlight	Repair Black Wire Connection Between Sealed Beam & Body Ground
Black Ground Wire Mislocated in Headlight Connection (Type 2 Sealed Beam)	Relocate as Shown in Service Circuit
<b>ONE OR MORE HEADLIGHTS—SHORT LIFE</b>	
Voltage Regulator Misadjusted	Check and Adjust if Necessary to Specifications.
<b>ALL HEADLIGHTS INOPERATIVE OR INTERMITTENT</b>	
Loose Connection	Check and Secure Connections at Foot Switch and Light Switch
Defective Foot Switch	Check Voltage at Foot Switch With 12-Volt Test Bulb. If Bulb Lights Only at Lt. Blue Wire Terminal, Replace Foot Switch.
Open Wiring - Light Switch to Foot Switch	Check Voltage at Lt. Blue Wire With Test Bulb. If Bulb Lights at Light Switch Lt. Blue Wire Terminal But Not at Foot Switch, Repair Open Wire.
Open Wiring - Light Switch to Battery	Check Voltage at Light Switch Red Wire Terminal With 12-Volt Test Bulb. If Bulb Fails to Light, Repair Open Red Wire Circuit to Battery (Possible Open Fusible Link)
Circuit Shorted to Ground	If, After a Few Minutes Operation, Headlights Flicker On and Off and/or a Thumping Noise Can be Heard From the Light Switch (Circuit Breaker Opening and Closing), Repair Short to Ground in Circuit Between Light Switch and Headlights. After Repairing Short, Check For Headlight Flickering After One Minute Operation. If Flickering Occurs, the Circuit Breaker Has Been Damaged and Light Switch Must be Replaced.
Defective Light Switch	Check Voltage at Light Switch Red and Blue Wire Terminals With Test Bulb. If Bulb Lights at Red Wire Terminal But Not at Lt. Blue, Replace Light Switch.
<b>UPPER OR LOWER BEAM WILL NOT LIGHT OR INTERMITTENT</b>	
Open Connection or Defective Foot Switch	Check Voltage at Foot Switch Headlight Terminals With Test Light. If Bulb Lights at Headlight Terminals (Lt. Green - U.B., Tan - L.B.), Repair Open Wiring Between Foot Switch and Headlights. If Bulb Will Not Light at One of the Foot Switch Headlight Terminals, Replace Foot Switch.
Circuit Shorted to Ground	Follow Diagnosis Shown Above Under "All Headlights Inoperative or Intermittent"

A-1810

Figure 32—Headlight Circuit Diagnosis

## HEADLIGHT SWITCH

The headlight switch controls the headlamps, parking lamps, tail lamps, marker and clearance lamps, instrument and dome lamps as well as instrument light intensity. The dome lamps are actuated by turning the headlamp switch fully counterclockwise. The headlamps are protected by a 25 amp. circuit breaker in the headlamp switch which is an automatic reset type. Before replacing the light switch, make sure the trouble is in the switch and not elsewhere in the lighting system by checking circuits as described in Figures 31 and 32.

## HEADLIGHT SWITCH REPLACEMENT

1. Disconnect negative battery cables.
2. Pull the switch knob out to the full "ON" position, then reaching up behind the instrument panel, press the spring-loaded release button on the bottom of the switch. Remove the switch rod and knob by pulling straight out with button depressed.
3. Remove the switch retaining nut by inserting a flat-blade screwdriver into the nut while holding the switch from behind the instrument panel.
4. Remove the switch from the instrument panel and disconnect the multiple wire connector from the switch.
5. Reverse steps 1-4 for switch installation.

## DIRECTIONAL SIGNALS

For diagnosis of hazard warning and directional signal systems, refer to STEERING (SECTION 9) of this manual.

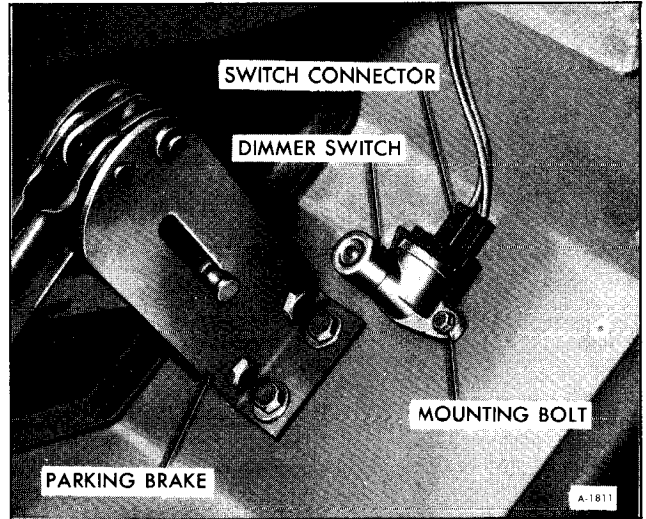

Figure 33-Dimmer Switch

## DIMMER SWITCH

The foot-operated dimmer switch (figure 33) is used to select headlight high or low beam. The switch is mounted on the left hand side of the drivers area floorboard and is operative when the headlights are illuminated. See Figure 32 for diagnosis details.

## DIMMER SWITCH REPLACEMENT

1. Fold back the carpeting or floor mat in the area of the switch (See figure 33).
2. Disconnect the wiring harness connector from the switch and remove the switch screws.
3. Push the wiring harness connector onto the replacement switch and check operation.
4. Position the switch on the floor panel or toe-board area and attach with (2) screws. Re-position floor mat.

## HORN

Two air-tone "S" type vibrating electric horns (figure 34) are mounted behind the left front access door. The electric air-tone "S" type horn is carefully adjusted and inspected during manufacture and should operate indefinitely without attention. The horn assembly should not be adjusted or repaired.

The horn relay-buzzer (figure 35) includes both the horn relay and door buzzer. The horn relay-buzzer operates when the vehicle door is open with the ignition key in the switch and the switch in the "off" position. Closing the door or removing the key will stop buzzer operation. The relay is located behind the right front access door.

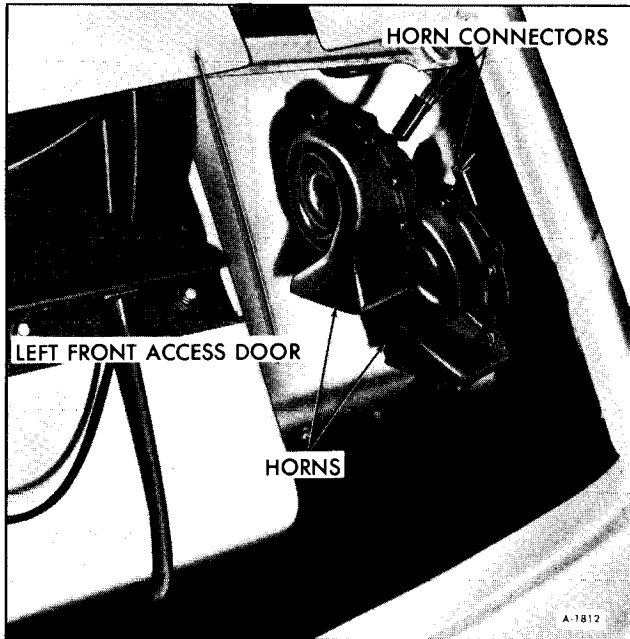

Figure 34-Horn Installation

Refer to ENGINE AND CHASSIS WIRING DIAGRAM for horn and door buzzer wiring circuit.

## HORN DIAGNOSIS

For diagnosis of horn system refer to Figure 36.

## COMPONENT REPLACEMENT

### HORN

1. Disconnect battery ground cables, then open left front engine access door and remove the dark green wires and connectors from the horn assembly.

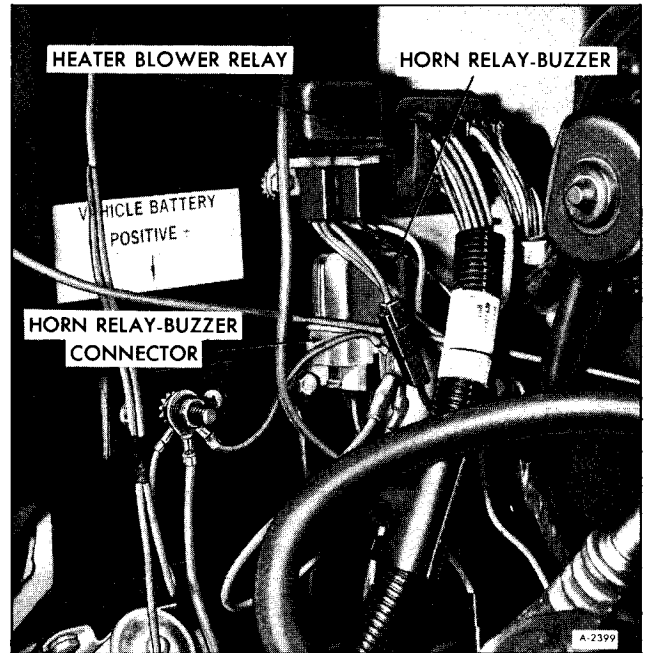

Figure 35-Horn Relay-Buzzer Installation

2. Remove the horn mounting bolts and remove horns (See figure 34).

3. Reverse steps to install horns and check operation.

### HORN RELAY-BUZZER

1. Disconnect battery ground cables.

2. Remove horn relay buzzer connector (figure 35).

3. Remove mounting bolt which attaches relay-buzzer to panel.

4. Install buzzer by reversing steps 1-3, making sure that headlamp ground wire is placed under relay mounting tab.

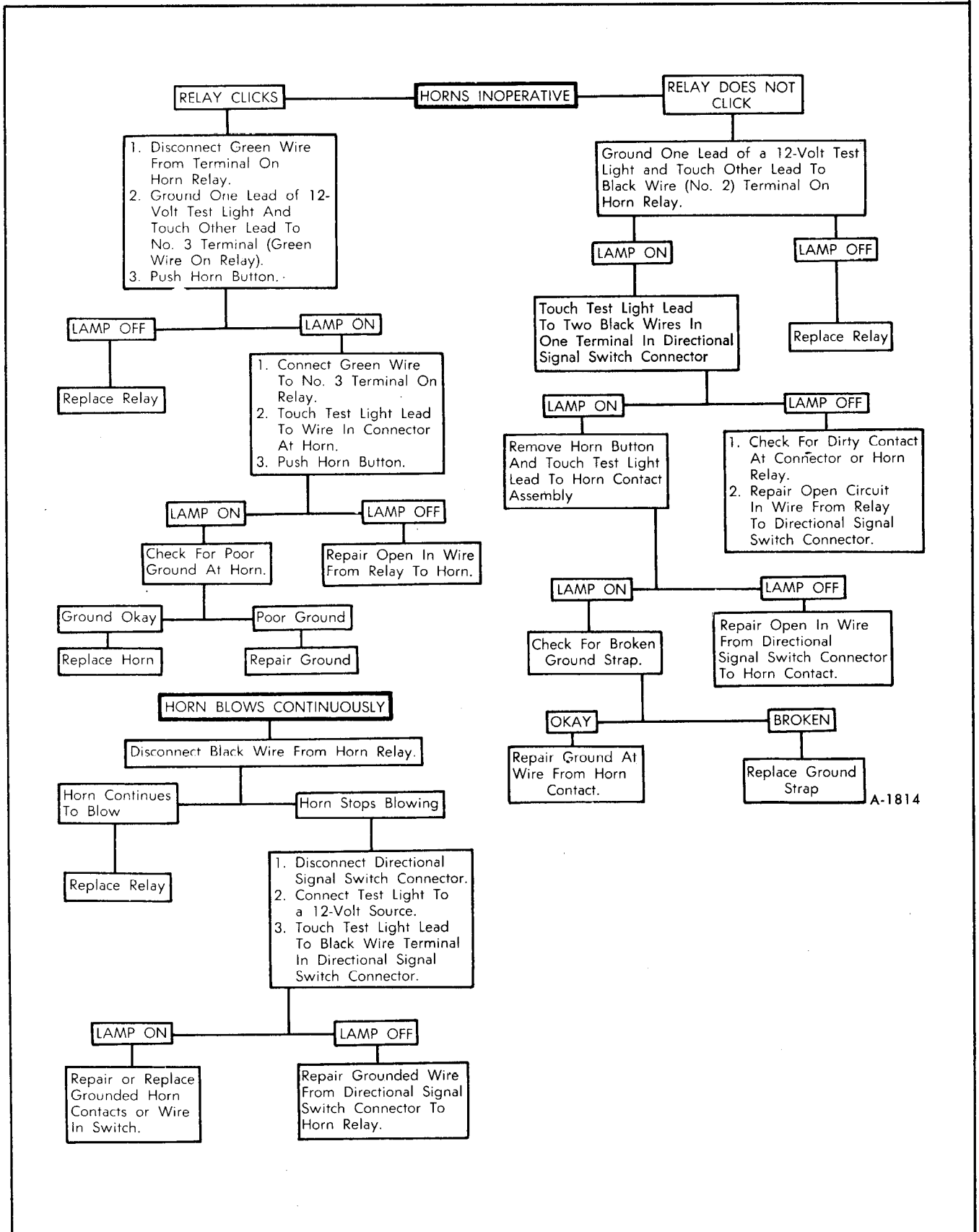

A-1814

Figure 36—Horn Diagnosis Chart

## RADIO AND TAPE PLAYER

Radio options include an AM radio, AM-FM, AM-Tape, AM-FM Stereo and AM-FM-Tape Stereo unit. There are two 3-1/2 inch speakers (figure 29) located in each of the front dome light panels and two in each of the rear corners of the vehicle. The antenna is roof mounted with coaxial cable running down the center windshield pillar to the radio.

On AM-FM receivers, a frequency band selector bar is used to change from the AM to FM reception. Moving the band selector bar to the left, engages the FM band and all preset FM stations. Conversely, moving the selector bar to the right engages the AM band. Any preset AM or FM station can be mechanically tuned by depressing the appropriate push button located directly below the band selector bar.

The FM section of the AM-FM and AM-FM Stereo radios is equipped with automatic frequency control, which aids tuning to a station. The FM receiver should be tuned directly on station frequency for minimum noise interference, however, the automatic frequency control will tune directly to and lock on station frequency when slight mistuning is encountered.

Another feature of FM tuning is signal separation. When two FM stations are close in frequency, the FM tuner selects the stronger signal, rejecting the weaker one. This is in contrast to AM performance, where it is not always possible to separate two stations.

The AM-FM radio incorporates an AM receiving circuit and an FM receiving circuit. The audio system is common to both receiving circuits.

On stereo radios, an indicator light on the right side of the dial, will indicate when the FM station tuned is capable of transmitting stereo programs.

With the AM/FM stereo radio and eight-track tape player, the operator may insert a tape cartridge into the opening behind the face of the receiver dial. When the dial face swings up, this automatically removes power from the radio and switches control of the speakers to the tape player. To change tape programs, momentarily depress the volume control knob. To eject the tape cartridge from the engaged position, depress the "EJECT" pushbutton. A cartridge should not be left inserted in the tape player due to possible tape damage.

### SPEAKER CONTROL

The right radio knob is used to tune stations

manually. The ring around the knob is the speaker control. When the ring is turned all the way counter-clockwise, 90% of the volume will be shifted to the front speakers. Turning the ring progressively clockwise will shift volume to the rear. When the radio is tuned to an FM-Stereo program, stereo separation will be from side to side.

### PUSH BUTTON TUNING

Each one of the five push buttons may be preset to a favorite AM station when on the AM band. Each one of these same five push buttons may be set to a favorite FM or stereo station, giving a total of 10 preset favorite stations. To preset push buttons, proceed as follows:

Select the desired band (AM or FM) and manually tune a favorite station until maximum signal is received. Pull push button out and then push all the way in to relatch. Ten favorite stations (5-AM and 5-FM) can be obtained in this manner.

**CAUTION:** *Do not move the AM-FM slide bar band selector while any push button is pulled out. Damage to the tuner mechanism may result.*

### RADIO NOISE SUPPRESSORS

Various types of ignition suppressors are used to prevent spark noise from interfering with radio reception.

1. Ignition noise is suppressed by use of resistance core ignition cables. The resistance of these cables is 2000 to 6000 ohms-per foot.

2. Make sure resistance spark plugs are being used to minimize ignition noise.

3. It is particularly important that the terminals in the ignition secondary cables make good mechanical contact with the spark plug terminals and distributor cap terminals. A loose connection at these points will result in excessive ignition noise, seriously reducing FM performance.

4. A capacitor mounted on the outside of the ignition coil may be checked by running the engine at medium speed and then quickly turning the ignition switch to the Accessory position. If the noise is



# RADIO TROUBLE DIAGNOSIS

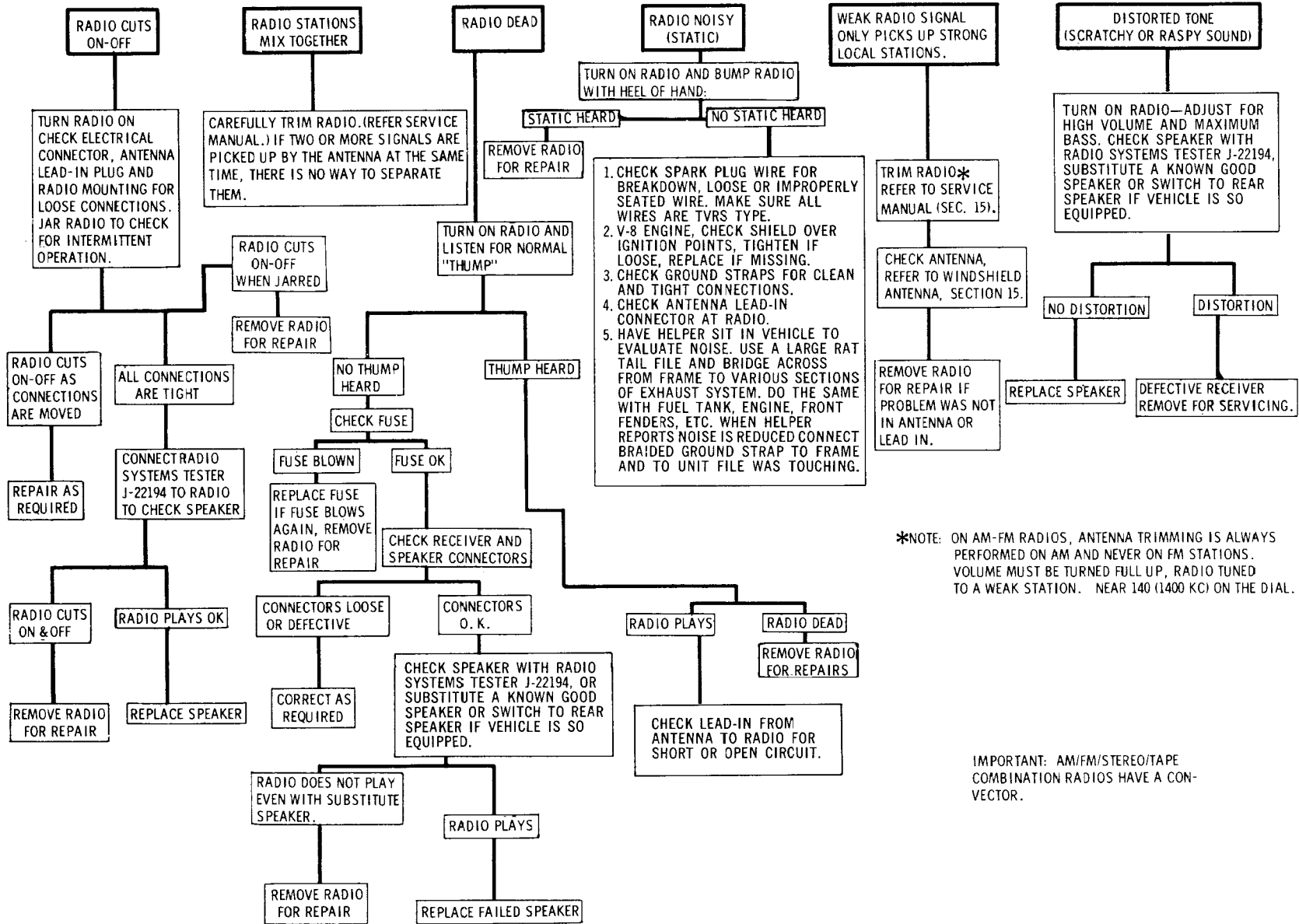

Figure 37—Radio Diagnosis

\* RADIO/TAPE PLAYER DIAGNOSIS

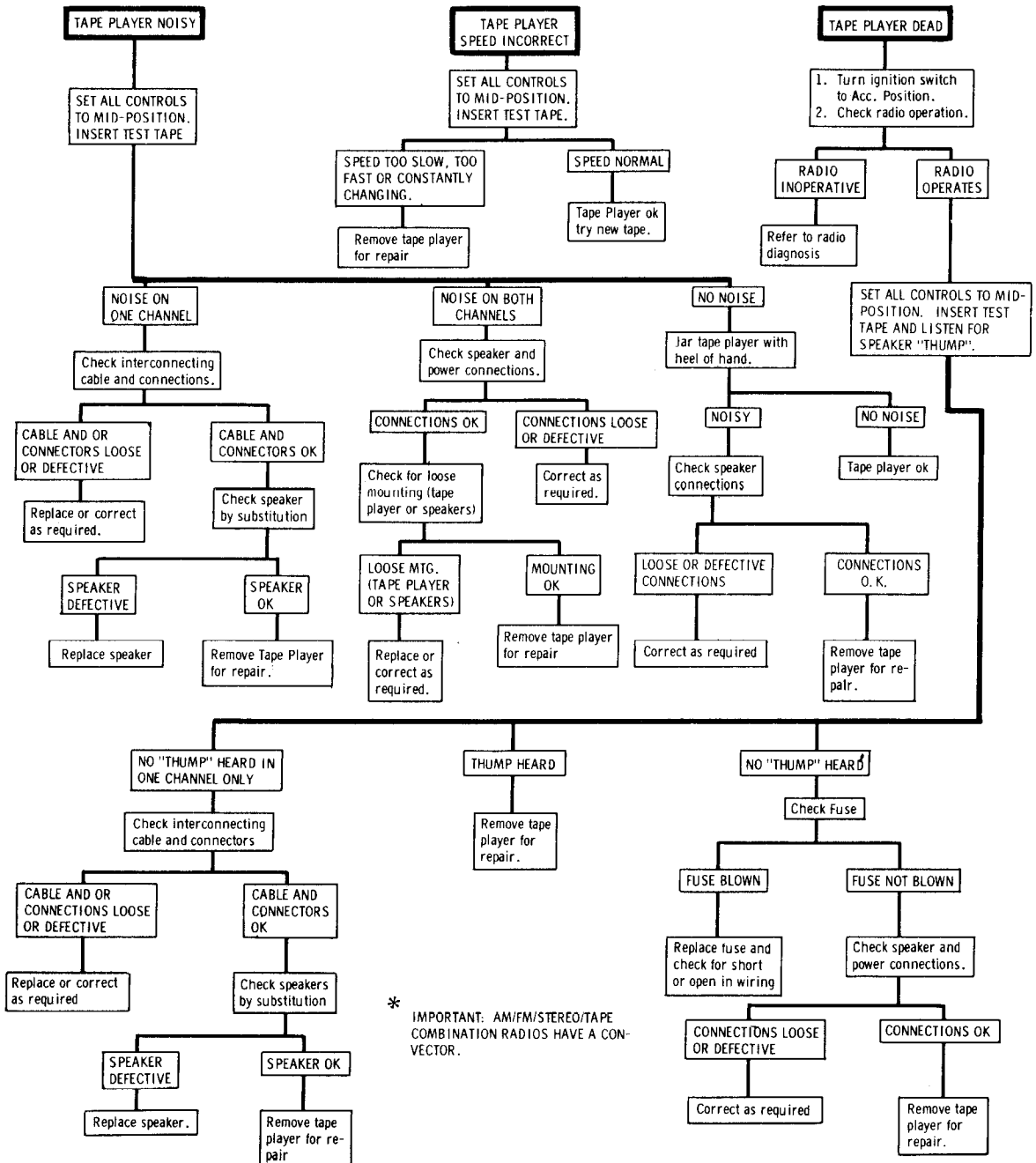

Figure 38—Tape Player Diagnosis

eliminated, while the engine is coasting to a stop, replace faulty coil capacitor.

5. A capacitor is mounted on the blower motor assembly for suppressing radio noise at high blower speeds. If a whine is eliminated when the blower is switched from HI to LO, this capacitor should be replaced.

## RADIO AND TAPE DIAGNOSIS

Many conditions that affect radio operation may be corrected without removing set from vehicle. If the checks in Figures 37 and 38 are performed and problem cannot be found, the radio should be removed and repaired at an authorized radio service station.

**CAUTION:** *Do not turn on radio with any speaker disconnected, as the radio transistor may be permanently damaged.*

## SERVICING

### ANTENNA TRIMMER ADJUSTMENT

**NOTE:** If antenna is not trimmed, the set will have weak and fading AM reception. Antenna trimming should always be performed after any radio or antenna repair work.

1. Turn radio on. Switch to AM band if radio is AM-FM.

2. Tune in a weak station at approximately 1400 kilohertz on the AM band and turn volume control to maximum.

3. Adjust antenna trimmer, located behind right control knob ring, for maximum volume. Access to antenna trimmer is gained by removing right control knob and ring and inserting screwdriver to adjust screw (figure 39).

**NOTE:** If, during adjustment, the station becomes strong so that a change in volume cannot be heard with further screw rotating, tune to a weaker station and continue the adjustment.

### ANTENNA MAST REPLACEMENT

If it becomes necessary to remove the antenna mast assembly, refer to Figure 40 for proper part positioning of mast components.

**NOTE:** Antenna cable passes through center windshield support as shown in Figure 18.

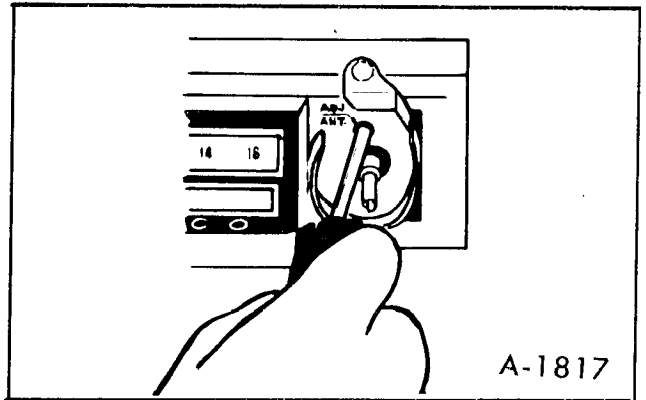

Figure 39—Antenna Trimmer Adjustment

### BALANCE ADJUSTMENT (AM-FM STEREO MODELS ONLY)

If the sound appears to be louder on one side of the vehicle than the other, and adjustment to the audio balance may be made.

**NOTE:** On some stereo programming, it is normal for one side to be louder than the other for a short time. This is done purposely for stereo effect. The only positive method to tell if the balance control needs adjustment is to tune in a non-stereo program and make a critical evaluation.

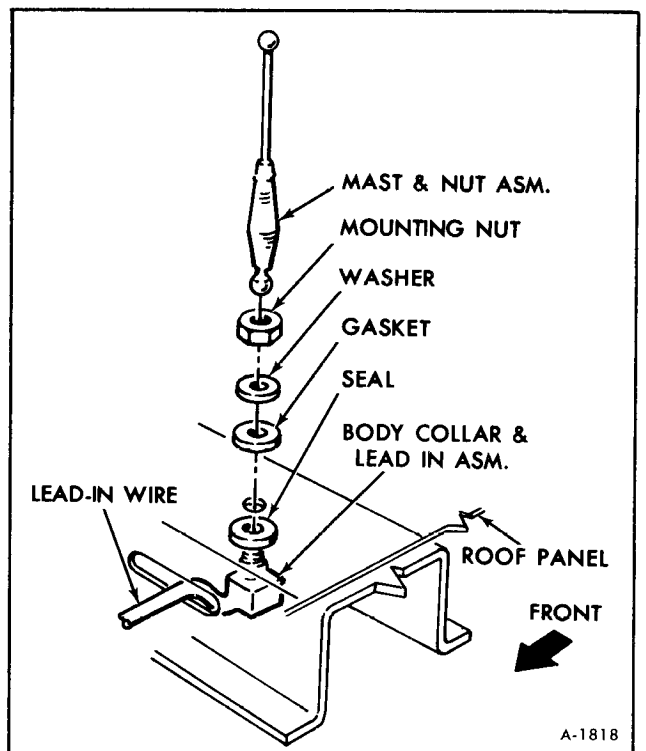

Figure 40—Antenna Mast Installation

If adjustment is needed proceed as follows:

1. Turn radio on. Switch to AM band.
2. Remove left knob, spring and control ring to gain access to stereo balance screw.
3. With fader control turned fully clockwise, insert screwdriver into balance screw.
4. Rotate balance control adjustment clockwise or counterclockwise until the sound in the left and right speakers appears to have equal volume.
5. Install left control ring, spring and knob.

### STEREO TAPE PLAYER

The only required maintenance on tape players is periodic cleaning of the tape player head. This service should be performed approximately every 100 hours of operation. If the tape slips and runs slowly, the capstan (revolving metal post), head and tape guide should be cleaned with a cotton swab moistened with alcohol. To clean capstan, trip the on-off switch at the rear of the receptacle and hold the swab against the rotating capstan.

No lubricants should be used since they will cause the player to operate improperly, especially at extreme temperatures.

Do not bring any magnetized tools near the tape head. If the head becomes magnetized, every car-trip played in the player will be degraded.

### STEREO TAPE PLAYER CONVECTOR (FIGURE 41)

On units equipped with a stereo tape player, power transistors are located on a remote heat convector due to space limitations. The convector assembly is located behind the glove box door. Connection is made to the convector by means of a 6 wire harness and plug connector running parallel to the fuse block wiring harness from the tape player.

If radio is to be removed for repairs, test the convector, USM radio repair stations do not need the convector to repair the radio if the convector is good.

### CONVECTOR TEST (FIGURE 42)

1. Remove the convector harness plug from the rear of the radio.

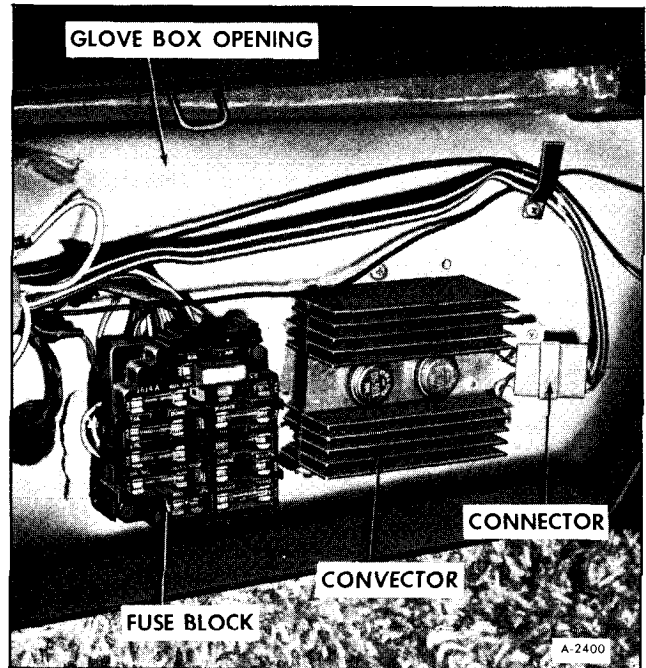

Figure 41—Convector Installation

2. Connect 12 volt test light to 12 volt source.
3. Connect jumper wire to good ground, touch test light probe to jumper to test connections. Test light should light.
4. Touch test light probe to blue wire; jumper to yellow wire.
5. Touch test light probe to blue/white stripe wire; jumper to yellow/white stripe wire.
6. If test light lights in either of the above tests, remove the convector for repair. If the test light is off in both tests, it will not be necessary to send the convector with the radio for repair.

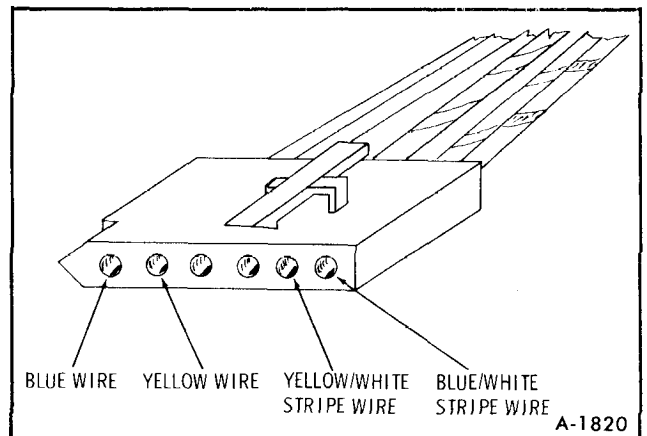

Figure 42—Convector Connector

## CONVECTOR REPLACEMENT

1. Convector is located behind glove box on vehicle bulbhead panel.
2. Remove the convector harness connector.
3. Remove the (2) retaining screws and remove convector (See figure 41).
4. To install, reverse steps 1-3.

## RADIO DIAL LAMP REPLACEMENT

Radio dial lamp replacement can be made using the following procedures:

### All Radio Models

1. Disconnect battery ground cables.
2. Remove the instrument panel bezel and rear cover.
3. Remove the radio knobs and rings.
4. Disconnect the wiring connectors from the rear of the radio and remove radio unit from the instrument panel.

5. Remove the (5) radio case top retaining screws and remove cover.

6. Remove the dial lamp bulb from the holder and replace.

7. To assemble, reverse steps 1-6 above.

### Stereo Indicator Lamp Replacement

In cases of a failed stereo indicator lamp on stereo radio models, remove radio and have service performed by an authorized Delco radio repair facility.

## MOBILE RADIO TRANSMITTERS

Mobile radio transmitting equipment is subject to Federal Communications Commission regulations and must be installed by a qualified radio technician. The specific installation instructions for radio transmitters will vary depending upon the radio equipment used. Mobile telephone equipment installed by your local telephone company, citizens band radios and electronic garage door openers will not adversely affect vehicle operation. In the event any other type of mobile radio transmitter is to be installed, further instructions are required so that vehicle operation will not be adversely affected. Contact GMC Truck Coach Division, General Motors Corporation, Technical Service Department, Pontiac, Michigan 48053 (or in Canada, contact General Motors of Canada Limited, Product Service Department, Oshawa, Ontario).

# CRUISE CONTROL

## GENERAL DESCRIPTION

The Cruise Control is a speed control system which employs engine manifold vacuum to power the throttle servo unit. The servo moves the throttle when speed adjustment is necessary by receiving a varying amount of controlled vacuum from the regulator unit. The speedometer cable from the transmission drives the regulator, and a cable from the regulator drives the instrument panel speedometer. The engagement of the regulator unit is controlled by an engagement switch located at the end of the turn signal lever. Two brake release switches are provided: an electric switch disengages the regulator unit and a vacuum switch decreases the vacuum in the servo unit to quickly return the throttle to idle position.

The operation of each unit of the system and the operation of the entire system under various circumstances is described below. Figure 43 shows the location of the system components within the vehicle. See Figure 46 for cruise control system checks.

## COMPONENT OPERATION

### ENGAGEMENT SWITCH

This switch, located within the turn signal knob, has three positions. In the fully released position, the switch passes current through resistance wire to effect a "hold in" magnetic field in the regulator solenoid. This current is sufficient only to hold the

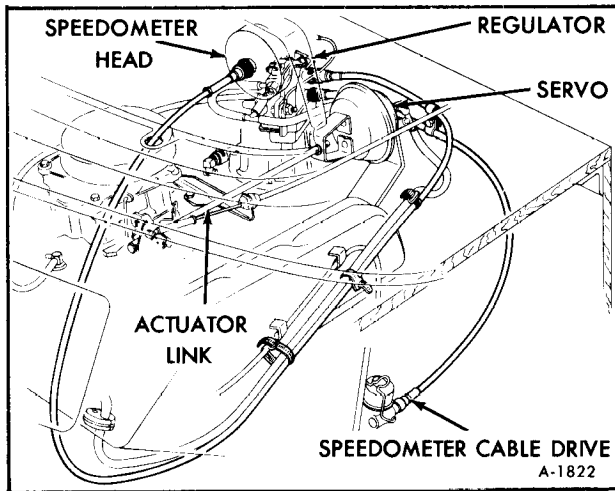

Figure 43—Cruise Control Component Location

solenoid in place once it has been actuated by the “pull in” circuit. Depressing the button partially allows current to flow to the regulator solenoid at full voltage which causes the solenoid to pull in. Depressing the button fully opens the circuit to both the resistance and standard solenoid feed wires and the solenoid becomes de-activated.

During vehicle operation the three switch positions have the following functions:

## RELEASED

a. System not engaged: No function of the system will occur although a small current is flowing through the solenoid via the resistance wire.

b. System engaged: The small current flowing through the resistance wire is holding the solenoid in the engaged position.

## PARTIALLY DEPRESSED

Full voltage is applied to the solenoid (vehicle speed over 35 mph) which sets the regulator to maintain the vehicle speed at the time of regulator engagement.

## FULLY DEPRESSED

No electricity flows to the solenoid and the regulator is inactive. This position is used by the driver when he desires to raise or lower his controlled

speed. He may accelerate to his new speed, press the button fully (regulator releases previously set speed) and release the button. Upon releasing the button, it passes through the partially depressed position and the solenoid is “pulled in”, then into released position which provides “hold in” current. The driver may also press the button fully with no pressure on the accelerator pedal. In this case the regulator releases control of the throttle which returns to idle and the vehicle slows. When the button is released the solenoid is pulled in and held in respectively and the regulator resumes speed control at the speed of the vehicle during the moment of button release (at vehicle speeds over 35 mph).

## BRAKE RELEASE SWITCHES

Two brake release switches are employed in the Cruise Control System. When the brake pedal is depressed; an electric release switch cuts off the voltage supplied to the engagement switch, hence cuts off power to the regulator unit. The regulator is then disengaged and requires engagement switch operation to return it to operation. A vacuum release switch operates simultaneously with the electric release switch whenever the brake pedal is depressed. This switch opens a port to atmospheric pressure which rapidly bleeds down the vacuum in the servo unit thereby returning the throttle to the idle position.

## SERVO UNIT

The servo unit is a vacuum actuated, variable position diaphragm assembly, which operates the carburetor throttle when the system is in operation. It is powered by controlled vacuum from the regulator and operates the throttle linkage via the adjustable link. (See figure 44) The servo has a port on the sealed side of the diaphragm housing. When controlled vacuum is applied to this port, atmospheric pressure moves the diaphragm which pulls on the adjustable link opening the carburetor throttle.

## REGULATOR

The regulator, Figure 45 is a device which has two primary functions. First, it is a vacuum switch which, when engaged by the driver, supplies vacuum to a “Tee” fitting. Second, it meters a small variable quantity of air to the “Tee” fitting where it blends with vacuum, thus providing the power unit with controlled vacuum which will maintain the selected

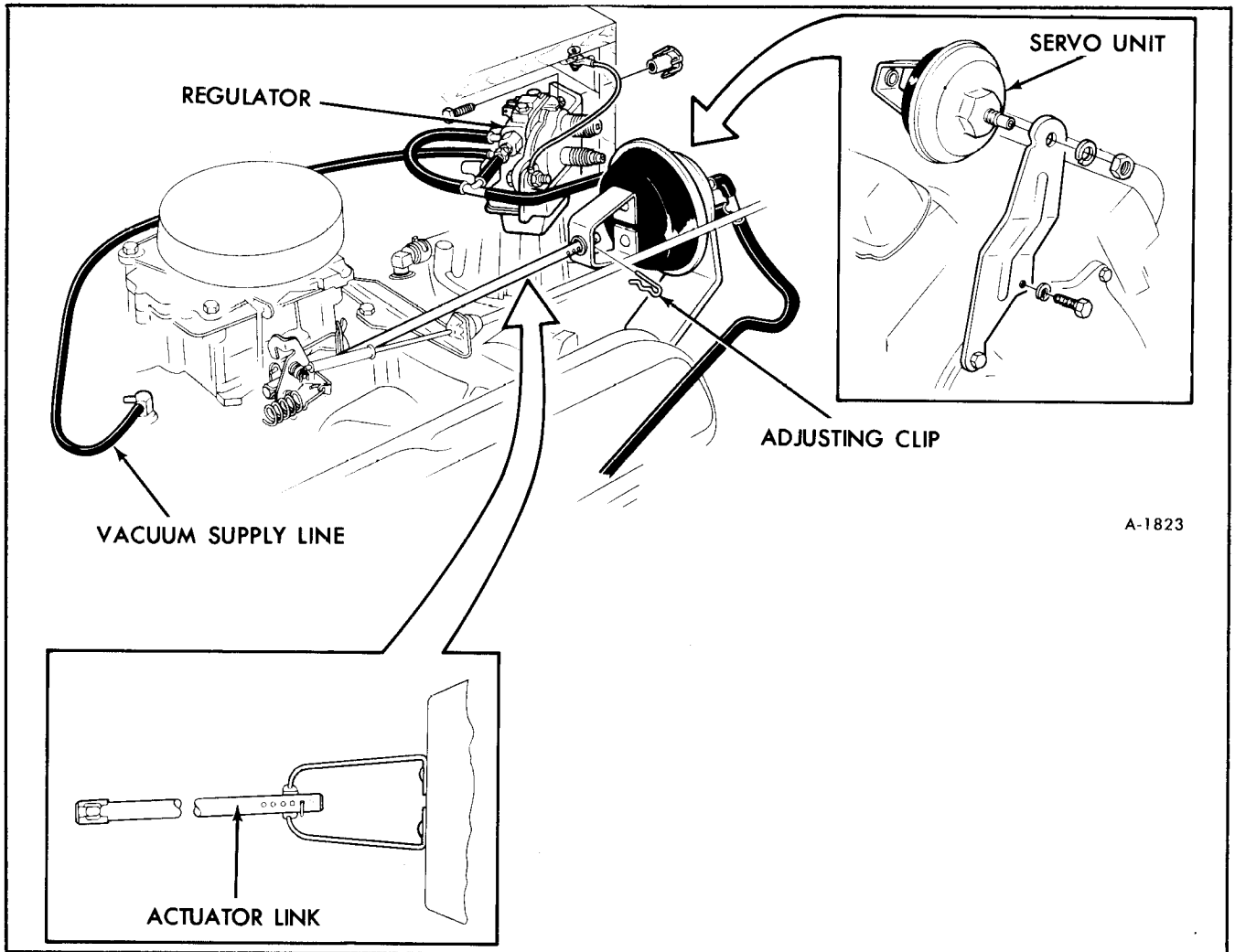

A-1823

Figure 44-Servo Unit Installation

speed. If the regulator begins to supply less bleed air (vehicle speed decreasing) the vacuum in the chamber increases and the diaphragm moves toward the vacuum port. If the regulator begins to supply more bleed air (vehicle speed increasing), the vacuum in the chamber drops and the diaphragm moves away from the vacuum port. In operation, at cruise speed, a proper balance of air and vacuum is blended at the "Tee" fitting and is imposed upon the servo unit to maintain an "on speed" cruise condition.

An additional function of the regulator is to drive the speedometer. Since the vehicle speed is sensed by a speedometer-like mechanism within the unit, the speedometer cable from the transmission drives the regulator which drives a second cable (at a one to one ratio) to the speedometer.

The regulator is electrically engaged and disengaged through operation of the engagement switch and the electric brake release switch. It has two subassemblies which make up the unit: one being the

magnetic speed sensing assembly and the other being the solenoid actuated vacuum switch, air bleed and filter, and low limit speed switch assembly.

#### Magnetic Speed Sensing Assembly

The speed sensing assembly operates in the same manner as a speedometer unit except that instead of rotating a needle through an angle proportional to the vehicle speed, it rotates a rubber drum which is clutched to the air bleed valve when the system is in operation. The assembly is driven by the speedometer cable from the transmission which turns a disk shaped ferrite magnet.

Facing the magnetic disk is the driven copper disk mounted on a shaft with the rubber drum mounted on the same shaft. A spiral hairspring connects the shaft to the housing and allows it to rotate

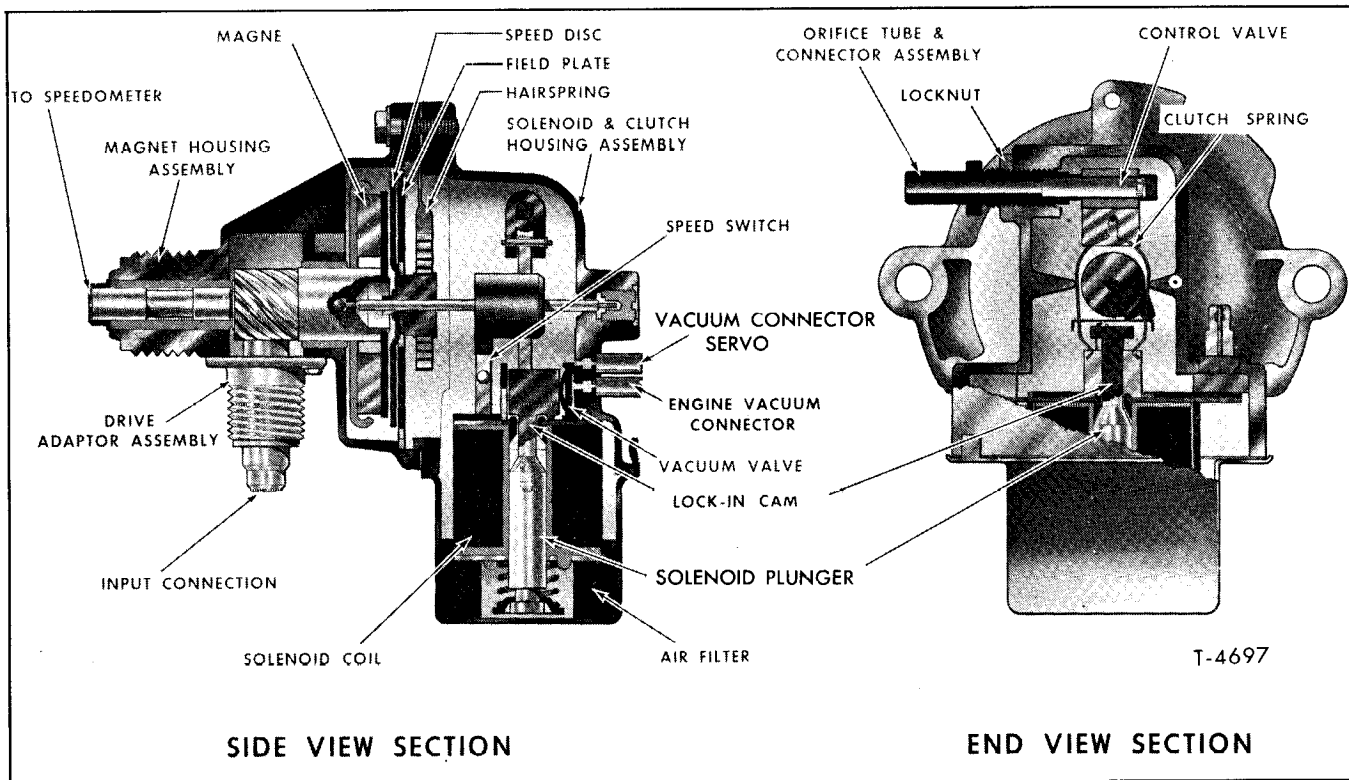

Figure 45-Regulator (Cross-Section)

through an angle which is proportional to vehicle speed. If the vehicle doubled its speed, the shaft would rotate to twice its previous angle as may be seen by noting the operation of a speedometer. The driven disk is sandwiched between the magnetic disk and a field plate. The field plate forms a returning path for the magnetic field from the magnetic disk.

The input shaft drives both the magnetic disk and the speedometer drive cable.

#### Vacuum Switch, Air Bleed and Filter, and Low Limit Speed Switch

The end of the shaft from the speed sensing assembly with the rubber drum extends into the air bleed metering assembly. This rubber drum has a tang extending from its surface which allows a set of points to close at a specific speed. When the vehicle reaches about 35 mph, the rubber drum has rotated far enough (moved by the brass driven disk in the magnetic field) so that its tang has allowed a spring loaded electrical point to contact another point. These points are in series with the solenoid coil so that under 30 mph, no regulator operation is possible.

Surrounding the rubber drum is a "U" shaped spring clip which is held spread away from the drum by the nose or cam of the solenoid when the solenoid is in the relaxed position. The rubber drum and this clip comprise the speed clutch of the regulator. When the solenoid is energized, the solenoid nose moves toward the drum and releases the ends of the clip. The clip springs inward and attaches itself by friction to the drum. Now, any change in vehicle speed will rotate the drum and move the "U" clip just as a speedometer moves its needle. The top of the "U" clip is attached to the air bleed valve. The clip moves a sleeve which slides on the orifice tube thereby covering and uncovering air ports in the wall of the tube (the tube inner end is plugged) whenever vehicle speed changes from the speed at which the solenoid was energized. The direction of drum rotation is such that resulting bleed valve operation will cause the servo to decrease engine power if the vehicle exceeds the preset speed and increase engine power if vehicle speed decreases. The air which passes out the orifice tube enters the regulator through the openings in the solenoid housing, passes through the oil wetted polyurethane filter, and then enters the orifice tube ports.

When the solenoid is de-energized, the nose retracts and cams the ends of the "U" clip outward so that it releases the rubber drum.



The solenoid also operates a vacuum switch simultaneously with the clutching and declutching of the "U" clip. The solenoid operated vacuum valve slides over two ports in the regulator wall. One port is connected to manifold vacuum and the other is connected to a "Tee" fitting. When the solenoid is de-energized, the valve closes the manifold vacuum port and opens the "Tee" port to the inside of the regulator case. When the solenoid is energized, the valve connects manifold vacuum to the "Tee" fitting, at which point air is blended to the proper proportion and impressed upon the servo unit according to the dictates of the regulator.

During system operation the following events occur:

1. Vehicle speed below 30 mph – no function of the pull-in circuit because the rubber drum has not rotated far enough to close the solenoid points. No pull-in current can flow through the solenoid coil. The solenoid coil is receiving a small current via the 40 ohm resistance wire unless the brake pedal is depressed, engagement switch fully depressed, or the ignition switch is "off".

2. Vehicle speed above 35 mph – the tang on the rubber drum has closed the solenoid points. The pull-in circuit is now ready for engagement.

3. Driver partially presses engagement switch – full voltage flows through the solenoid to pull it into operation. Solenoid cam tension on the "U" clip is released and the clip grips the rubber drum. Simultaneously, the vacuum switch applies manifold vacuum to the "Tee" fitting. Here the vacuum is blended with air being introduced from the regulator. The balance of air and vacuum is impressed upon the servo to provide for initial throttle positioning.

4. Driver releases the engagement switch – current flows to the solenoid through the 40 ohm wire and since the solenoid is "pulled in", the reduced current flow is sufficient to hold it in position.

5. The vehicle begins to ascend a hill – vehicle speed drops slightly (very slightly) and the magnetic force on the driven disk of the speed sensor is decreased. The disk rotates slightly (as would a speedometer shaft because of hairspring tension) turning the rubber drum. Since the "U" clip is gripping the drum, it moves the air bleed valve in that direction which covers the air bleed ports more. With less air bleeding into the "Tee" fitting a higher vacuum level is achieved at the Servo diaphragm, opening the throttle angle to correct for the underspeed condition.

6. The vehicle begins to descend a hill – vehicle speed increases slightly and the air bleed valve moves

in that direction which uncovers the air bleed ports. With more air bleeding into the "Tee" fitting, a lower vacuum level is achieved at the servo diaphragm decreasing the throttle angle to correct for the overspeed condition.

7. Driver accelerates by pressing accelerator pedal – vehicle speed increases and the system responds by moving the diaphragm to decrease throttle opening. Since an adjustable link is used, the link merely slips through the hole in the servo unit and has no effect on throttle operation. After the driver releases pressure from the pedal, the throttle will close until vehicle speed decreases to the pre-set speed. At that point the regulator bleeds less air to the "Tee" fitting which opens the throttle enough to maintain the pre-set speed. The system returns to a stable condition.

8. Driver desires higher controlled speed, presses accelerator until new speed is reached, and depresses engagement switch fully and releases button – speed sensing assembly tries to turn in a direction that would decrease the throttle opening until the driver fully depresses the engagement switch. Then the current is cut off to the solenoid which retracts; the solenoid cam expands the "U" clip releasing its grip on the rubber drum. The drum and disk assembly then rotates to a new position because of the higher vehicle speed. When the solenoid retracts, it also shuts off vacuum to the "Tee" fitting and opens the vacuum port to atmospheric pressure within the regulator thereby bleeding down the servo toward the relaxed position. As the driver releases the engagement switch, "pull-in" and "hold-in" of the solenoid occurs, respectively. The system is now engaged to maintain the vehicle speed at the time of engagement switch release.

9. Driver desires lower cruising speed, presses engagement switch fully, waits until vehicle speed decreases to desired speed then releases switch – when the engagement switch is fully depressed the solenoid is de-energized causing the vacuum switch to bleed down the servo to idle throttle position and the "U" clip of the air bleed valve is released from the rubber drum. The drum and disc assembly is free to rotate to a position which corresponds to vehicle speed as the vehicle slows. When the driver releases the engagement switch, the unit "pulls in" and "holds-in" in the normal manner. The air bleed valve is clutched to the rubber drum at the vehicle speed corresponding to switch release. Vacuum is again applied to the "Tee" fitting and throttle control is assumed by the regulator to maintain the vehicle speed at the time of switch release.

10. With system in operation, driver applies brakes – simultaneously the vacuum release and electric release switches operate. The vacuum switch bleeds air into the servo. The vacuum is reduced in

Problem	Cause	Correction
Will not engage—System Inoperative	Brake Switch Circuit Open Clutch Switch Circuit Open	Check connections— adjust or replace switch. Refer to Electrical Check Out.
	Fuse blown	Replace fuse—if it blows again, check for: 1. Engage Switch stuck in the center of travel— Refer to Electrical Check Out. 2. Incorrect wiring—Refer to Electrical Check Out. 3. Short to ground—Refer to Electrical Check Out. Make necessary corrections.
	Defective Engage Switch	Replace as needed—Refer to Electrical Check Out.
	Vacuum leak in Servo and/or Brake Switch and connecting lines. Vacuum hose not connected to vacuum switch.	Vacuum test and repair or replace as needed. Refer to Servo and Vacuum System Check Out.
	Vacuum release switch misadjusted (always open)	Readjust switch.
	Crossed hoses at regulator	Reroute hoses.
	Open in wiring harness	Repair or replace as needed.
	Pinched or plugged hose that is connected to the Servo.	Free or replace hose.
	Defective Regulator	Replace Regulator
Does not cruise at engagement speed	Orifice Tube misadjusted	Adjust as required.
System hunts, pulses or surges	Actuator Link	Actuator Link
	Kinked or deteriorated hoses (air leak)	Repair or replace.
	Defective and/or improperly positioned Drive Cables and/or Casing Assemblies	Repair or replace as needed.
	Defective Regulator	Replace Regulator.
System does not disengage—with brake pedal	Brake and/or Vacuum Switch mis-adjusted or defective	Adjust or replace as required. Refer to Servo and Vacuum System Check Out and Electrical Check Out.
	wires [which should be connected to the pedal switch(es)] connected to the fuse block	Reroute wires to stoplight switch.
System steadily accelerates or applies full throttle when engaged	Manifold vacuum connected directly to Servo.	Reroute hose.
	Defective Regulator	Replace Regulator.
Cannot adjust speed downward with Engage Button	Defective Engagement Switch or Wiring	Replace as needed. Refer to Electrical Check Out.
Does not engage or engages lower than limits referred to in "Driver Operation"	Defective Regulator	Replace Regulator.
Slow throttle return to idle after brake is depressed.	Pinched air hose at vacuum release switch	Free or replace hose.
System operates correctly, but constant vacuum bleed when system is disengaged.	Crossed vacuum hoses at regulator	Reroute hoses.
High engine idle speed—independent of carburetor adjustments. Constant air bleed through system.	Tight Servo Link	Loosen adjustment.
Constant drain on battery.	Power lead connected to "Fused Battery" terminal of fuse block	Reroute to "Fused Ign." terminal.
System can be engaged at idle by depressing switch, but will drop out when switch is released. Solenoid can be heard when switch is depressed when the vehicle is standing still.	Wires reversed at regulator	Reverse wires.

Figure 46—Cruise Control System Diagnosis

the servo and the throttle returns to idle position. The electric release switch cuts off power to the entire system and the solenoid is de-energized. If the driver removes his foot from the brake pedal the electric switch again feeds voltage to the engagement switch and the vacuum switch seals the air bleed line. The unit will not re-engage since it receives only a small current through the 40 ohm resistance wire. If vehicle speed is below 30 MPH the system may not be re-engaged since the tang on the rubber drum has opened the low limit switch points in the regulator.

## DIAGNOSIS

For details on cruise control diagnosis refer to Figure 46.

## SERVICING

The components of the Cruise Control system are designed to be replaced should they become inoperative.

The regulator is calibrated in such a manner during manufacturing that overhaul operations are impractical. However, one adjustment may be made to the regulator to correct speed drop or increase at the time of engagement.

## BRAKE RELEASE SWITCHES

### ELECTRIC

**Service**—An inoperative switch must be replaced. Switch replacement is identical to standard brake lamp switch replacement.

**Adjustment**—The brake switch plunger must clear the pedal arm when the arm is moved 1/4 inch measured at the switch. (figure 47)

### VACUUM

**Service**—An inoperative (sticking, plugged, or leaking) switch must be replaced. Switch replacement is similar to brake switch replacement. Be certain that the hose to the switch is connected firmly and is not cracked or deteriorated.

**Adjustment**—The brake switch plunger must clear the pedal arm when the arm is moved 5/16 inch measured at the switch. (figure 47)

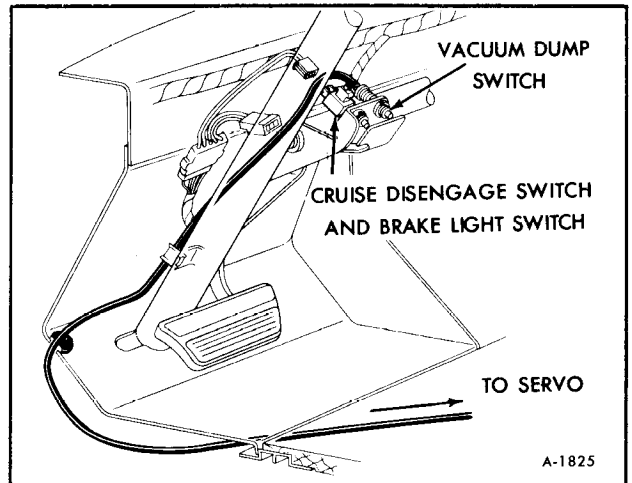

Figure 47—Brake Release Switches

## ENGAGEMENT SWITCH

**NOTE:** The engagement is serviced only by replacement.

## REMOVAL

1. Disconnect battery ground cables.
2. Pry the engagement button out of the turn signal knob with a small thin bladed screwdriver.
3. With a small hook or long nosed pliers, remove the switch retaining ring.
4. Remove steering wheel to gain access to turn signal lever attaching screw. Remove screw. Remove turn signal lever from turn signal housing utilizing the slack in the wiring harness.
5. Push slack into turn signal lever slot at base of lever (attachment end). This will force switch out of the other end of the lever.
6. With a small soldering iron, unsolder the wires and resolder them to the correct terminal of the replacement switch. Use only rosin core solder.

## INSTALLATION

1. Once a new switch is installed, pull it back into the lever by pulling on the harness at the lever slot.
2. Reinstall retaining ring and button.

3. Push wire slack into turn signal housing; reinstall turn signal lever and steering wheel.
4. Connect battery ground cables.

## SERVO

**NOTE:** If the servo unit is found to be defective, replacement is required. Note the condition of the hoses and replace any which are cracked or deteriorated.

**Adjustment**—Adjust the actuator link so that it is as tight as possible without holding the throttle open when the carburetor is set at its lowest idle throttle position. When connecting, (engine stopped) manually, set the fast idle cam at its lowest step and connect the link so that it does not hold the idle screw off the cam. (See figure 44)

## REGULATOR

A defective regulator, that is one which is not simply out of adjustment, must be replaced. During replacement, check the hoses which connect to the regulator and replace any which are cracked or deteriorated.

## ADJUSTMENT

One regulator adjustment is possible: Engagement-cruising speed zeroing (to remove any difference between engagement and cruising speed).

**NOTE:** No regulator adjustment should be made, however, until the following items have been checked or serviced.

1. Actuator link properly adjusted.
2. All hoses in good condition, properly attached, not leaking, not pinched or kinked.
3. Electric and vacuum release switches properly adjusted.

## ENGAGEMENT-CRUIISING SPEED ZEROING

If the cruising speed is lower than the engagement speed, loosen the orifice tube locknut and turn the tube outward; if higher, turn the tube inward.

Each 1/4 turn will alter the engagement-cruising speed difference one mph. Tighten the locknut after adjustment and check the system operation at 60 MPH.

## ELECTRICAL SYSTEM CHECK OUT

(Refer to Figure 48)

1. Check fuse and connector.

2. Check electric brake switch as follows: Unplug connector at switch. Connect ohmmeter at points A and B on brake switch. The ohmmeter must indicate infinity when the pedal is depressed and continuity when pedal is released. The cruise release brake switch (electric) is adjusted as is the standard stop light brake switch. Replace electric brake switch if needed.

3. Check engagement switch and connecting wiring as follows: Unplug engagement switch connector (brown, black) at electrical wiring harness connector and perform the following tests.

Test #1 – Connect ohmmeter between terminal #1 (brown wire) and terminal #2 white (white wire). Continuity shall be maintained until switch is depressed all the way in.

Test #2 – Connect ohmmeter between terminal #1 (brown wire) and terminal #3 (black). No continuity shall be shown; however, when the button is depressed halfway, continuity shall be indicated. When the button is pressed all the way down, no continuity shall be shown.

Test #3 – Connect ohmmeter between terminal #2 (white wire) and terminal #3 (black). Button released, no continuity; however, when the button is depressed partially and fully, continuity shall be shown.

4. Disconnect engage switch wire harness connector from the main harness connector (brown, brown/white, black wires). Connect ohmmeter between point C (brown/white stripe wire in main wire harness) and ground. Make sure the regulator is well grounded to the chassis. The ohmmeter should read between 42 and 49 ohms. If a resistance either above or below the value indicated is shown, then disconnect the connector from the regulator and measure the resistance of the brown/white stripe wire from point C to D. It should measure 40 ohms  $\pm$  2 ohms. If a resistance either above or below the value indicated is shown, the main wiring harness should be replaced. Note: When disconnecting or reconnecting

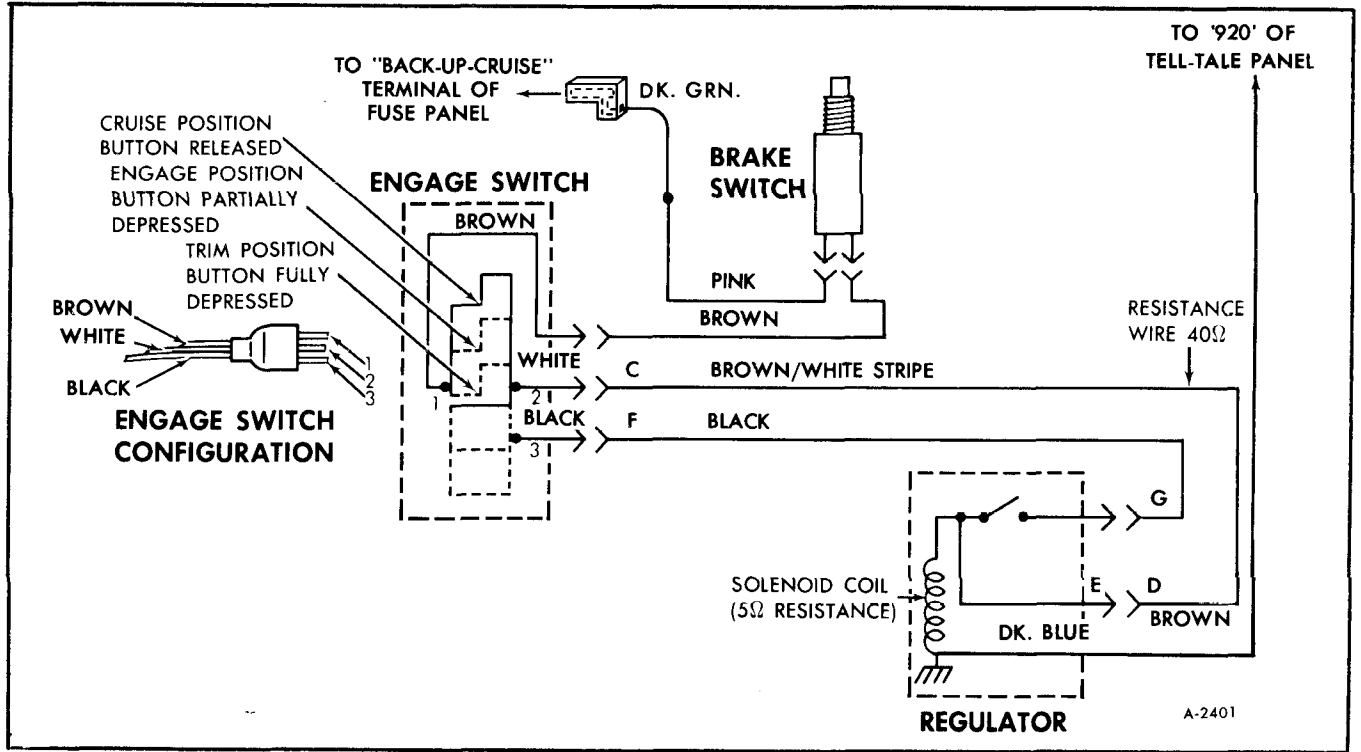

Figure 48-Cruise Control Electrical Diagram

the main wiring harness connector from the regulator, care should be exercised so as not to damage the blade connectors or the wiring harness. The disconnect may be facilitated by prying carefully on the plastic connector with a small blade screw driver.

When measuring the solenoid coil circuit resistance between Point E (Hold Terminal) to ground the

ideal ohmic resistance should be between 5 and 6 ohms. A reading of less than 4 ohms indicates shorting in the coil circuit. A reading of more than 7 ohms indicates excessive resistance in the coil circuit. Either extremity indicates replacement of the regulator assembly. The white main harness wiring from Point F to G should also be checked for continuity.

### ENGAGEMENT SWITCH TEST

BUTTON POSITION	TERMINALS		
	1 TO 2	1 TO 3	2 TO 3
Cruise (released).....	closed	open	open
Engage (partially depressed) .....	closed	closed	closed
Trim (fully depressed) .....	open	open	closed

**SERVO AND VACUUM CHECK OUT**

To determine the condition of the diaphragm, remove hose from servo unit and apply 14 inches of vacuum to the tube opening and hold in for one minute. The vacuum shall not leak down more than 5 inches of vacuum in one minute. If leakage is detected, replace servo. To utilize engine as as vacuum source, proceed as follows:

1. DISCONNECT SERVO adjustable link and

hose from servo then connect engine vacuum directly to the servo fitting.

2. Note position of servo diaphragm.
3. Start engine – the diaphragm should pull in.
4. Clamp off engine vacuum supply line and check for leakage.

The cruise release brake switch (vacuum) and connecting hoses can likewise be checked using a vacuum pump.

**LIGHT BULB SPECIFICATIONS**

Bulb Application	Quantity	Bulb No.	Part No.
Low Air Tell-Tale .....	1	74	
Brake System Tell-Tale.....	1	161	
Generator Tell-Tale .....	1	161	
Park Brake Tell-Tale .....	1	74	
Cruise Control Tell-Tale .....	1	74	
Door Ajar Tell-Tale .....	1	74	
Low Fuel Tell-Tale .....	1	74	
Power Level Tell-Tale .....	2	74	
High Beam Indicator.....	1	161	
Turn Signal Indicator .....	2	168	
Instrument Cluster Light .....	2	194	
Speedo Cluster Light .....	2	194	
Dome Lights .....	2	211	9422525
Radio Dial (AM/FM Stereo/Tape).....	1	566	
Radio Dial (exc. AM/FM Stereo/Tape).....	1	1893	
Heater Control .....	1	1895	
Clearance and I.D.....	10	67	142450
License .....	1	67	
Side Markers.....	4	194	9421330
Back Up Lights.....	2	1156	
Parking and Turn Sig. ....	2	1157	9428902
Stop and Tail .....	2	1157	
Headlights .....	2	6014	5962548
Fiber Optic Bulb.....	1		9433143



# SECTION 13

## RADIATOR AND COOLANT RECOVERY SYSTEM

Contents of this section are listed below:

SUBJECT	PAGE NO.
Description .....	13-1
Maintenance .....	13-1
Radiator Mountings .....	13-2
Radiator Replacement .....	13-2
Pressure Relief Valve and Filler Cap .....	13-3
Coolant Recovery System .....	13-3
Engine Coolant .....	13-3
Cooling System Pressure Relief Valve .....	13-4
Torque Specifications .....	13-4

**NOTE:** Refer to *ENGINE COOLING (SECTION 6K)* of this manual for information relative to coolant circulation, temperature indicators, thermostats, and fan belts.

Refer to **GENERAL INFORMATION AND LUBRICATION (SECTION O)** for information relative to coolant recommendations and coolant system capacities.

### DESCRIPTION

All GMC Motor Homes are equipped with a cross-flow radiator also a coolant recovery system. The level in the coolant recovery reservoir should be maintained at the "COLD" line when coolant is cold.

At normal operating temperatures, level can reach "HOT" line on reservoir. However, should the coolant level fall below the cold level line, additional coolant, other than for draining and refill should be added through the coolant recover reservoir.

### MAINTENANCE

At regular intervals, cooling system components should be inspected to determine if service is required. Regular systematic checks will reveal faulty condition of various units and indicate necessity of servicing or replacement of such components before failure occurs.

Suggested checks are:

1. Frequently check coolant level. If low, add recommended coolant as required.

2. Check hose connections and tighten clamps if seeping is evident. Cracked, stripped, or corroded clamps should be replaced.

3. Inspect radiator hoses for spongy or checked appearance. Deteriorated hoses should be replaced before bursting occurs which would result in coolant loss and could cause extensive engine damage due to overheating.

4. Check radiator core for leaks and for accumulation of dirt which obstructs air passages and reduces effective heat transfer.

To assist in maintaining efficient heat dissipation, an occasional external flushing with water will remove majority of dirt accumulation and foreign matter from between core fins.

Water under moderate pressure should be directed from behind core to force debris out in opposite direction of its entrance. Water should be directed in line with fins, not sideways, to reduce possibility of bending fins.

5. Inspect radiator mounting pads for deterioration and replace as required.

6. Inspect for proper clearance between fan blades, radiator core venturi ring, and shroud. Check

## 13-2 RADIATOR AND COOLANT RECOVERY SYSTEM

fan attaching bolts for tightness and observe alignment of fan blades in relation to each other. Replace fan if any blade is bent. Distance between blades and venturi ring should be equal around entire perimeter of the ring. If adjustment is required, venturi ring attaching bolts may be loosened and the ring shifted as necessary to provide proper clearance.

7. Check radiator filler cap seals for evidence of cracking or separation. Replace as required.

8. When coolant loss is evident or engine overheating occurs, the damaged or clogged radiator should be serviced by a radiator specialist or replaced with a new one. Efficient repair of radiators requires the use of special tools and equipment as well as provisions for making proper tests. If radiator core requires painting, spray with special radiator paint; do not use paint mixed with oil, as oil mixed paint will form an insulation and prevent efficient dissipation of heat.

### RADIATOR MOUNTING

Refer to Figure 1 for mounting details of radiator support, radiator core, fan shroud and venturi ring.

### RADIATOR REPLACEMENT

1. Drain radiator by opening drain cock assembly at lower corner of radiator assembly (location of drain cock shown in figure 1).

2. If unit is equipped with air conditioning, perform the following:

a. Remove front grille.

b. Disconnect air conditioning condenser from radiator.

3. Disconnect radiator overflow tube and upper radiator hose.

4. Raise vehicle.

5. Disconnect lower radiator hose transmission cooler and engine oil cooler lines.

6. Disconnect upper radiator support channel assembly.

7. Remove upper shroud to support bolts (2) and clips attaching seal and venturi ring.

8. Remove retaining strap and move seal away from venturi ring.

9. Remove (2) lower shroud to support bolts & lower shroud.

10. Remove radiator support bolts (3) on each side and lower radiator and support from vehicle.

11. Replace radiator core in radiator support.

12. Install radiator and support in vehicle and torque attaching bolts to 25-30 ft.-lbs.

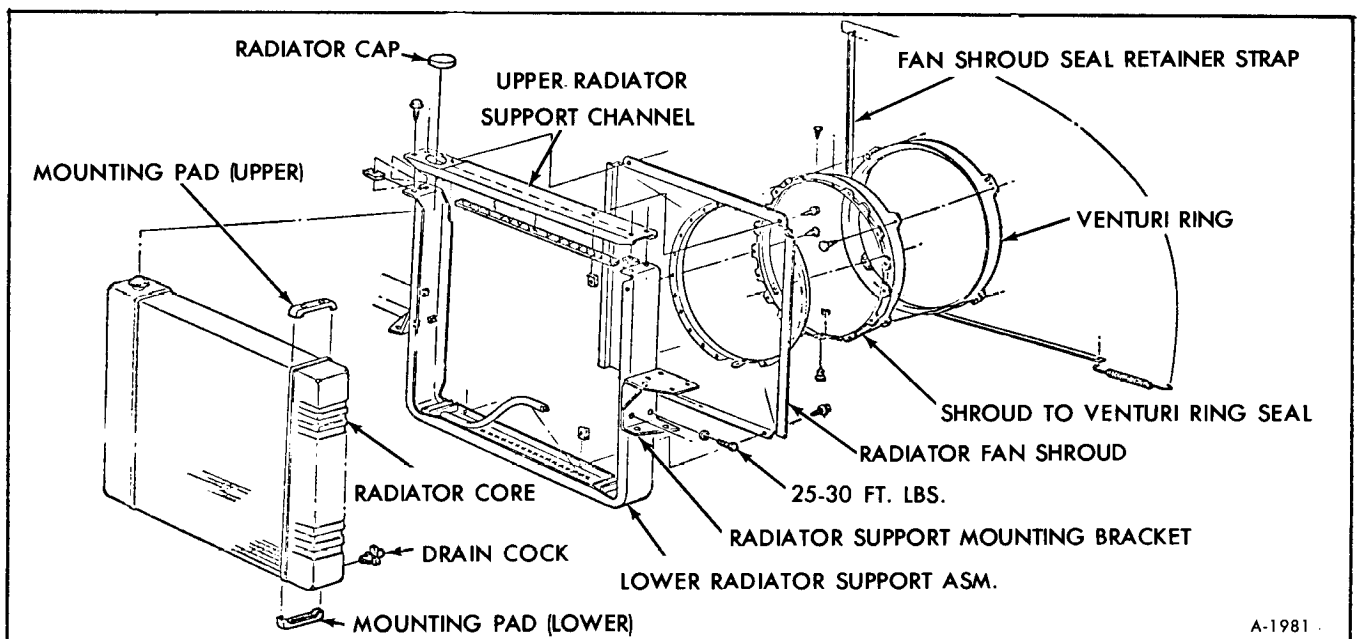

A-1981

Figure 1-Radiator Assembly



13. Install lower shroud to support bolts (2).
14. Install upper support channel assembly bolts (2).
15. Connect lower radiator hose, transmission and engine oil cooler lines.
16. Install shroud to venturi ring seal and tighten fan shroud seal retainer strap.
17. Install clips attaching venturi ring seal to shroud.
18. Install upper shroud to support bolts (2).
19. Lower vehicle.
20. Connect radiator coolant recovery hose and upper radiator.
21. Connect air conditioning condenser attaching bolts (if so equipped).
22. Install front grille.
23. Refill radiator following the procedure described in Section 6K.

## PRESSURE CAP AND VALVE

A pressure relief valve assembly, integral with the radiator filler cap, incorporates a pressure valve and a vacuum valve. (See figure 2) When pressure in system reaches valve setting (See "Specification" at end of this section), pressure valve opens and liquid is allowed to escape. As liquid in the system cools it

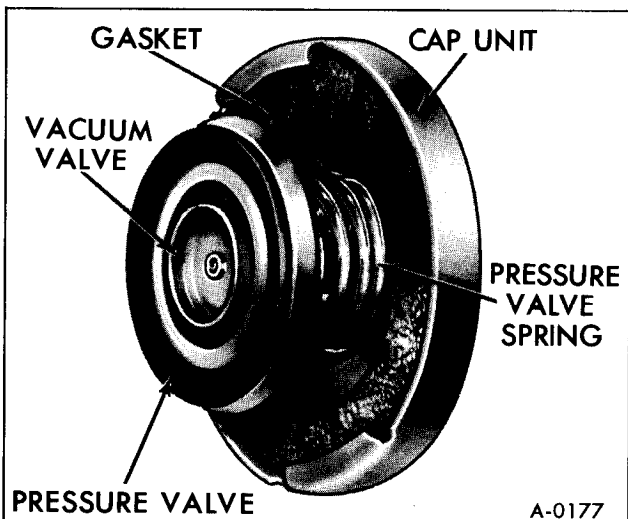

Figure 2—Pressure Cap

contracts; this allows pressure valve to close and also creates a partial vacuum in system. Atmospheric pressure acting through the overflow tube unseats the vacuum valve and allows coolant to enter radiator.

The radiator filler cap is constructed with a spring-loaded rubber seal which is pressed firmly against surface of filler neck seat when cap is installed. Rubber seal must be in good condition and top of radiator filler neck must be clean and smooth in order to form an air-tight seal. Seal of filler cap and operation of pressure relief valve can be checked using a conventional cooling system testing kit.

**CAUTION:** *When the engine is at normal operating temperature or above, the internal pressure built up in the cooling system will blow out scalding fluid and vapors if the radiator cap is suddenly removed. To prevent loss of coolant and to avoid the danger of being burned, the coolant level should be checked, or coolant added, only to the coolant recovery reservoir. If the radiator cap must be removed when the engine is hot, place a cloth over the cap and rotate the cap slowly counterclockwise to first stop and allow pressure to escape completely. Then turn cap again slowly counterclockwise to remove.*

## COOLANT RECOVERY SYSTEM

The coolant recovery system consists of a reservoir, pressure cap and interconnecting hose. The reservoir is mounted above the radiator and is accessible from the front access doors and connected to the radiator filler neck with a hose. The coolant level must be maintained at the "COLD" mark on the side of the reservoir when coolant is cold. A gasket incorporated into the filler cap forms a seal at the radiator filler neck. A leak at this gasket will result in loss of coolant during normal operation. The pressure cap must be installed so that the marking on top of the cap aligns with the overflow tube on the filler neck.

Refer to Figure 3 for removal and installation of coolant recovery system components.

## ENGINE COOLANT

### COOLANT RECOMMENDATIONS

For coolant drain and refill procedure, refer to SECTION 6K of this manual. Cooling system maintenance intervals will be found in SECTION O.

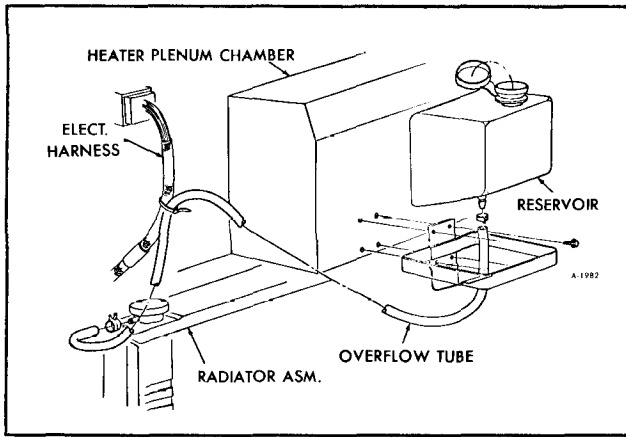

Figure 3-Coolant Recovery System

### COOLANT TESTING

Always test solution before adding water or anti-freeze. Engine should be warmed up to operating temperature. Fill and empty tester several times to warm tester before using. Keep tester clean inside and out.

Some testers will indicate correct freezing point only when test is made at a specific temperature. Other testers are provided with thermometers and tables and indicate freezing points corresponding to readings made at various temperatures. Disregarding temperatures of solution may cause an error as large as 30°F. Read and be guided by instructions furnished by the tester manufacturer.

In the event coolant freezes solid in extreme cold weather, place vehicle in warm building or improvise some means of thawing coolant before starting engine. Under no circumstance should engine be operated, when coolant is frozen solid. After thawing, refill system with a higher concentration of anti-freeze solution and start engine. Inspect entire system for leakage and then test coolant with hydrometer to determine if adequate anti-freeze protection is provided.

### COOLANT PRECAUTIONS

1. Overheating is not always caused by a defective cooling system; incorrect ignition timing, dragging brakes, under-inflated tires, can cause overheating.
2. Keep water pump and fan drive belts at proper tension. Refer to ENGINE COOLING SYSTEM (Section 6K) of this manual.
3. Do not remove radiator filler cap when engine is hot. Wait until system cools off.
4. Do not pour cold water into cooling system when the engine is hot. Wait until system cools off.
5. If cooling system requires frequent refilling, check for leaks.
6. Keep all connections tight, and make sure gasket on radiator filler cap is in good condition.
7. When filling system with anti-freeze solution. Always follow recommendations of anti-freeze manufacturer.
8. Use only Ethylene Glycol base coolant meeting GM Specification 1899M.
9. Drain and flush cooling system every other year, preferably at start or end of winter operation.

### COOLING SYSTEM PRESSURE RELIEF VALVE

Models	Valve Stamped	Opening PSI
230 (23') 260 (26')	RC32	9

### TORQUE SPECIFICATIONS

- Radiator Support Mounting Bracket to Radiator Support Attaching Bolts ..... 25-30 ft. lb.
- Drain Cock ..... 8-10 ft. lb.

# SECTION 14

## BUMPERS

### ENERGY ABSORBERS

#### DESCRIPTION

All GMC Motor Homes have both bumpers mounted to energy absorbers. (figure 1)

The energy absorber is a device which uses hydraulic fluid within the cylinder tube to absorb impact energy and inert gas to restore the bumper to its original position after a low speed collision. Right and left energy absorbers are the same. (figure 1)

During impact (figure 2) the piston tube moves back into the cylinder tube. Hydraulic fluid is forced from the cylinder tube through the orifice around the metering pin into the piston tube. The metering pin controls the rate of fluid flow. Fluid pressure in the piston tube against the floating piston moves it and compresses the gas. After impact (figure 3), gas pressure against the floating piston forces fluid back into the cylinder tube and pushes the bumper back to its original position.

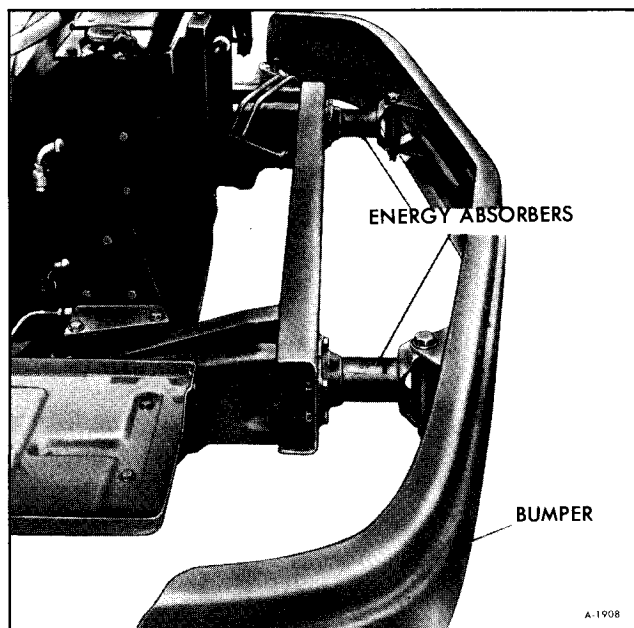

Figure 1—Energy Absorbing Bumper

#### DIAGNOSIS

##### LEAKAGE

A trace of oil on the piston tube is normal due to grease packed in the seal area during manufacturing. If oil is dripping from the unit it should be replaced.

##### DAMAGE

Inspect the bumper bracket, frame bracket, piston tube and cylinder tube for evidence of visible distortion. Scuff marks on the piston tube are normal. If there is obvious damage to the unit it should be replaced.

##### ON VEHICLE TEST

This test involves compressing EACH unit separately  $3/8$ " or more and observing that the bumper returns to its normal position.

1. Turn off ignition, transmission in park, parking and service brakes set.
2. Use a barrier such as a pillar, wall, post, etc.
3. Align a pressure device, such as a hydraulic jack, with the energy absorber. Make sure it is positioned squarely with the bumper so it will not slip.
4. Apply pressure to compress the unit  $3/8$ ". Use a 6" scale to determine travel. Release pressure and note if the bumper returns to its normal position.
5. If either unit fails to return to its normal position, replace it.

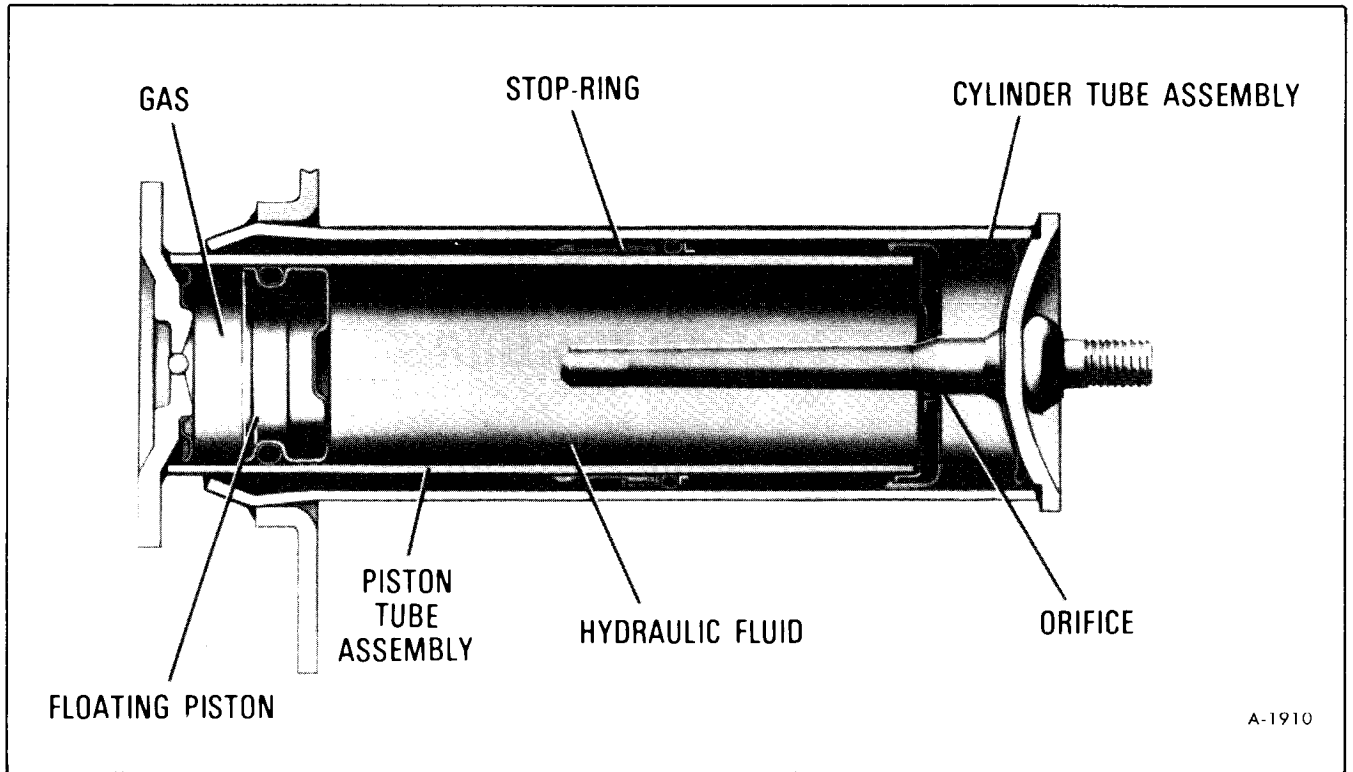

Figure 2—Energy Absorber—Collapsed Position

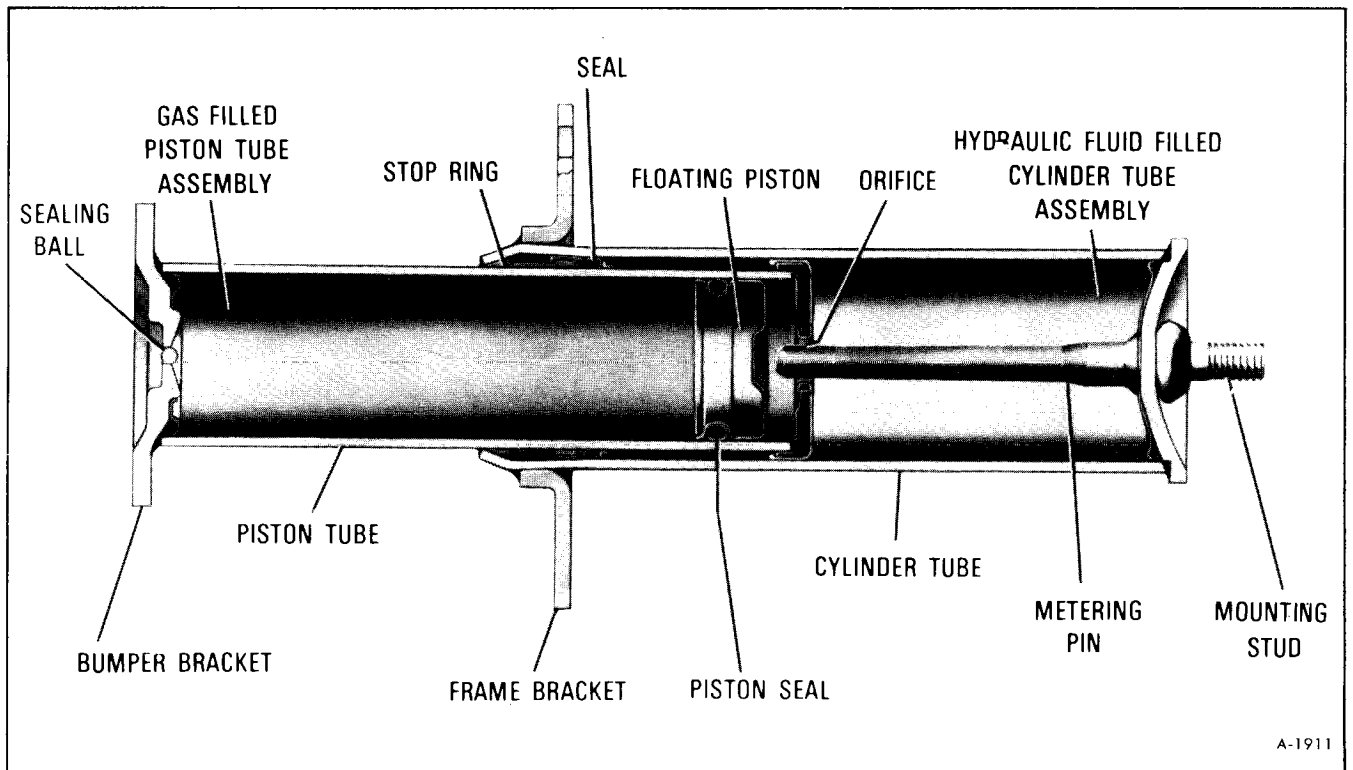

Figure 3—Energy Absorber—Extended Position

## BENCH TEST

The bench test may be used to pre-test service units prior to assembly on a vehicle or to check detached units that may have been removed for the purpose of making vehicle repairs after a collision.

A suitable arbor press should be used to compress the unit  $3/8"$ . Observe if it returns to its normal position. If not, this unit should be replaced.

## INSPECTION

Recommendations for handling energy absorbers are:

1. Do not attempt to repair.
2. Do not weld.
3. Do not apply heat.

**WARNING: BE SAFE! PROTECT YOUR EYES. WEAR APPROVED SAFETY GLASSES.**

4. Relieve gas pressure prior to disposal of a unit. Make an indentation with a center punch in the small cylinder section of the energy absorber (recommend "WARNING" label on the unit as a target area). Then, use a 1/8-inch drill to penetrate the small cylinder and relieve gas pressure (See figure 4).

## INSPECTION AFTER COLLISION

If the collision was so severe that the bumper did not return to its original position, the energy absorber(s) will require replacing.

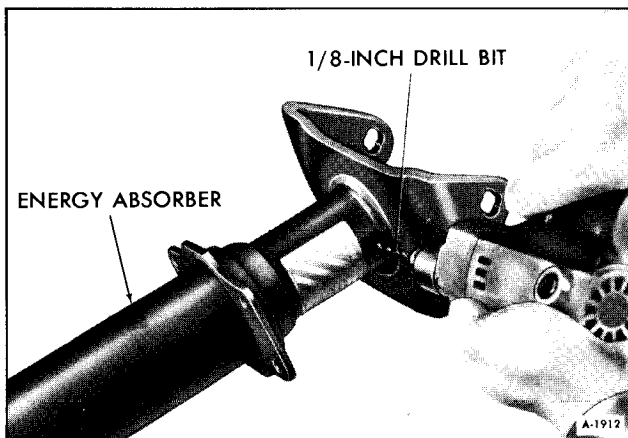

Figure 4—Relieving Pressure from Energy Absorber

**WARNING: BE SAFE! PROTECT YOUR EYES. WEAR APPROVED SAFETY GLASSES.**

1. Stand clear of the bumper.
2. Provide positive restraint, such as a chain or cable.
3. Relieve the pressure by drilling a 1/8-inch hole in the piston tube near the bumper bracket (See figure 4).
4. Remove the unit from the vehicle as described under "Replacement" only after the gas pressure has been relieved.

## REPLACEMENT

**NOTE:** Front and rear bumpers and energy absorbers are similarly mounted so replacement procedures are the same for front or rear.

**IMPORTANT:** Prior to replacement, be familiar with procedures given under "INSPECTION" of energy absorbers.

1. Remove bumper by removing both bumper bracket thru bolts as shown in Figure 5.
2. Remove the four bolts and nuts securing energy absorber to frame.
3. Secure new energy absorber to frame with bolts and nuts. Torque to 45 foot pounds.
4. Install bumper on energy absorbers and secure with thru-bolts.

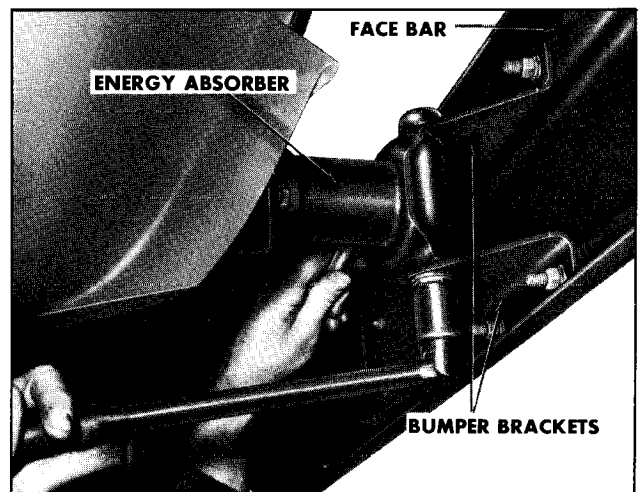

Figure 5—Removing Bumper Bracket Thru-Bolts

## BUMPER FACE BARS

**NOTE:** Front and rear bumper face bars are similarly mounted so replacement procedures are the same for front and rear. Also, due to the fact that both front and rear bumper face bars are two piece assemblies in some cases it may only be necessary to replace half of the face bar.

### REPLACEMENT

1. Remove face bars by removing both bumper bracket thru- bolts (See figure 5).
2. Remove brackets and hardware from old face bar(s) and install on new face bar(s).
3. Once it has been determined that the energy absorbers are operative, install the face bar assembly on energy absorbers and secure with thru-bolts.



# SECTION 24 MISCELLANEOUS LIVING AREA FACILITIES

Contents of this section are listed below:

SECTION	PAGE NO.
24A - Periodic Maintenance and Lubrication .....	24A-1
24B - Living Area Electrical .....	24B-1
24C - Motor Generator .....	24C-1
24D - Refrigerator.....	24D-1
24E - Roof-Mounted Air Conditioner.....	24E-1
24F - LP Gas System.....	24F-1
24G - Furnace .....	24G-1
24H - Range/Oven .....	24H-1
24J - Living Area Water System .....	24J-1
24K - Toilet.....	24K-1
24L - Holding Tank and Drainage System.....	24L-1
24M - Thermasan System .....	24M-1
24N - Cabinets and Furniture .....	24N-1
24P - Exhaust Vents.....	24P-1
24Q - Other Equipment .....	24Q-1



# SECTION 24A PERIODIC MAINTENANCE AND LUBRICATION

## PERIODIC MAINTENANCE

### MOTOR GENERATOR MAINTENANCE INTERVALS

Regularly scheduled maintenance is the key to lower operating costs and longer service life for the

unit. The following schedules (figures 1 and 2) can be used as a guide. However, actual operating conditions under which a unit is run should be the determining factor in establishing a maintenance schedule. When operating in very dusty or dirty conditions, some of the service periods may have to be

SERVICE THESE ITEMS	AFTER EACH CYCLE OF INDICATED HOURS						
	8	100	200	400	500	1000	1500
General Inspection	4,000/6,000 watt						
Check Oil Level	4,000/6,000 watt						
Change Crankcase Oil		4,000/6,000 watt (1)					
Clean Air Cleaner		4,000/6,000 watt (1)					
Check Spark Plugs		4,000/6,000 watt					
Fuel Filter—Check				4,000 watt (2)	6,000 watt (2)		
Check Breaker Points		4,000 watt 6,000 watt(2)					
Clean Cooling Fins			4,000/6,000 watt (1)				
Change Oil Filter			4,000/6,000 watt (1)				
Replace Breaker Points			4,000 watt				
Replace Air Cleaner			4,000 watt (1)		6,000 watt (1)		
Remove Carbon From Heads			4,000 watt		6,000 watt		
Adjust Tappets				4,000 watt	6,000 watt		
Check Generator Brushes						4,000 watt	6,000 watt
Complete Reconditioning (If Required)						4,000 watt	6,000 watt

(1) Perform more often in extremely dusty conditions.

(2) Replace if necessary.

Figure 1—Onan Motor Generator Maintenance Schedule



SERVICE THESE ITEMS	AFTER EACH CYCLE OF INDICATED HOURS			
	8	50	100	200
General Inspection	X			
Check Oil Level	X			
Change Crankcase Oil (1)		X		
Clean Air Cleaner Element		X		
Replace Air Cleaner Element			X	
Check Spark Plugs			X	
Clean Cooling Fins				X
Check Breaker Points				X
Replace Fuel Filter			X	
General Tune-Up				X

(1) Initial oil change after 5 operational hours.

A-2075

Figure 2-Kohler Motor Generator Maintenance Schedule

reduced. Check the crankcase oil, the filters, etc., frequently until the proper service time periods can be established.

Additional information about the items on this schedule may be found later in this section.

## LIVING AREA WATER PUMP BELT

Check the living area water pump belt for wear and adjust tension as necessary every 3 months or 3,000 vehicle miles, whichever occurs first. See "Living Area Water System" Section 24J for adjusting information.

## WINTERIZATION

When traveling in winter it is recommended that the water tank not be filled until the destination is reached. This will ensure that the vehicle has

thoroughly warmed up. The water and holding tank systems should be drained before leaving for home.

Also, an approved plastic pipe non-toxic, non-flammable antifreeze should be put in the sink and shower traps. If equipped with a recirculating toilet the standard winterization is to replace one-half of the charge water with an approved plastic pipe non-toxic, non-flammable antifreeze. This antifreeze added to the holding tank will help keep the tank contents from freezing.

See "Vehicle Storage" for additional information.

**CAUTION:** *If the vehicle is equipped with a Thermasan waste destruction system, it is especially important that flammable cleaning agents, solvents or other highly combustible materials never be allowed to enter the holding tank via the kitchen or bathroom sinks, toilet or shower drains. These materials could create an explosion hazard in the vehicle exhaust system.*

## VEHICLE STORAGE

The Motor Home may be stored for considerable lengths of time provided the following steps are performed:

### 1. SHORT TERM STORAGE - UP TO 60 DAYS AND ABOVE 32° F.

a. Fill fuel tanks to reduce excessive build-up of moisture in the fuel tanks.

b. Park Motor Home as level as possible, end for end and side to side.

c. Wash Motor Home. If exposed to road salts the exterior and underside should be thoroughly washed and flushed.

d. Check to make sure battery boost switch is left in the "BAT NORMAL" position. If left in the "BAT BOOST" position for extended periods, battery discharge will occur.

e. Remove all perishables, leave refrigerator door open. Be sure controls are turned off.

f. Ventilate the living area, drawers, cabinets, closets, etc.

g. Drain the holding tank, toilet and living area water system as described earlier in this section. Be sure the water pump and water heater are turned off.

h. Turn off LP gas at tank valve.

i. Make sure furnace manual valve and thermostat are set at "OFF," range/oven burners at "OFF," oven at "PILOT OFF" and gas/electric refrigerator control at "GAS OFF."

j. Plug or tape all drains to retard evaporation of residual moisture in drain traps.

k. Tape over vents to prevent insects from entering. Be sure to remove tape before operating LP gas appliances to help avoid poisoning by carbon monoxide.

l. Check Motor Home weekly to ensure that undesirable conditions are not forming (water seepage, mold, odors, etc.). Household air deodorizers or disinfectants in aerosol cans may be used as required, however, do not spray directly on any surface.

m. Maintain tire pressure of 60 psi.

n. Crack one window for ventilation, close all others as well as roof vents.

o. Check batteries (main, auxiliary and motor generator, if equipped) for charge. Specific Gravity reading of 1.255 is required to prevent deterioration. Add colorless, odorless drinking water, if necessary.

p. Turn off radio, exterior lights, and interior lights.

q. If Motor Home is to be moved, run engine at least two minutes with the transmission selector in "PARK."

r. Start and run engine for approximately 15 minutes weekly. Check engine, transmission and motor generator oil levels. Dipsticks should always be properly seated on tubes to prevent moisture from entering.

## 2. LONG TERM STORAGE – 60 DAYS OR MORE AND ABOVE 32° F.

a. Perform all of the above steps except for Step r.

b. Motor Homes without automotive air conditioning; remove spark plugs and squirt each cylinder

with "Super Engine Oil Supplement" available at your GMC Motor Home service outlet. Replace spark plugs.

c. Motor Homes with automotive air conditioning; run engine approximately 15 minutes with automotive air conditioning controls turned to "ON" position. Perform this operation every 30 days.

d. Treat all bright metal and rubber surfaces with a wax emulsion applied with a brush. A good liquid floor wax or equivalent is satisfactory.

e. Disconnect batteries, and check Specific Gravity every 30 days.

## 3. WINTER STORAGE – BELOW 32° F.

a. While many of the steps in preparing your Motor Home for storage when temperatures go below 32° F. are the same as preparing for storage above 32° F., freezing temperatures present an additional hazard.

b. Fill fuel tanks to reduce excessive build-up of moisture in the fuel tanks.

c. Check coolant level and add antifreeze if required, to protect to the lowest expected temperature during storage (at least – 35° F.).

d. Change engine oil as shown on the recommended S.A.E. Viscosity Chart to aid cold weather starting.

e. Park Motor Home as level as possible, end for end and side to side.

f. Wash Motor Home. If exposed to road salts, the exterior and underside should be thoroughly washed and flushed.

g. Check to make sure battery boost switch is left in "BAT NORMAL" position. If left in the "BAT BOOST" position for extended periods, battery discharge will occur.

h. Remove all perishables and anything which may freeze (canned goods, medicine, etc.). Leave the refrigerator door open. Be sure controls are turned off.

i. Ventilate the living area, drawers, cabinets, closets, etc.

j. Drain the holding tank, toilet and living area water system as described earlier in this section. Be sure the water pump and water heater are turned off.

k. Turn off LP gas at tank valve.

l. Make sure furnace manual valve and thermostat are set at "OFF," range/oven burners at "OFF," oven at "PILOT OFF," and gas/electric refrigerator control at "GAS OFF."

m. Add recreational non-toxic, non-flammable antifreeze (1/2 cup) to the kitchen, bathroom, and shower drains.

n. Tape over drain openings (except toilet) to prevent evaporation if storage is lengthy (6 months or more).

o. Crack one window for ventilation, close all other as well as roof vents.

p. Start and run engine weekly for approximately 20 minutes. If very low temperatures are expected the batteries should be removed and stored in a warmer area.

q. Check engine transmission and motor generator (if equipped) for evidence of oil leaks.

r. Maintain tire pressure of 60 psi.

s. Remove accumulations of snow as often as possible.

t. Turn off radio, exterior lights, and interior lights.

u. Tape over vents to prevent possible entry of snow. Be sure to remove tape before operating LP gas appliances, to help avoid poisoning by carbon monoxide.

v. Before moving, run engine at least two minutes with the transmission selector in "PARK" position.

## **ONAN MOTOR GENERATOR STORAGE**

If the motor generator will be out of service for more than 30 days, the following steps should be taken to protect the unit.

1. Run the unit until thoroughly warm.

2. Disconnect fuel supply and run until unit stops.

3. Drain oil from crankcase while still warm. Refill and attach a warning tag stating oil viscosity used.

4. Remove each spark plug. Pour one ounce of rust inhibitor (or S.A.E. 50 oil) into each cylinder. Crank engine several times. Install spark plugs.

5. Service air cleaner.

6. Clean governor linkage and protect by wrapping with a clean cloth.

7. Plug exhaust outlet to prevent entrance of moisture, dirt, bugs, etc.

8. Wipe entire unit with a clean cloth. Coat rustable parts with a light film of grease or oil.

## **KOHLER MOTOR GENERATOR STORAGE**

If the motor generator will not be used for an extended period of time, follow this procedure:

1. Drain oil from crankcase (while hot), then flush with clean light oil. Refill crankcase after flushing.

2. Drain fuel from sediment bowl and carburetor.

3. Clean exterior of plant, then spread a light film of oil on unpainted metal surfaces.

4. Remove spark plug and pour a tablespoon of oil (S.A.E. 30) into spark plug hole, turn engine over several times. Spark plug should be reinstalled.

5. Service air cleaner.

6. Plug exhaust outlet to prevent entrance of moisture, dirt, bugs, etc.

# **LUBRICATION**

## **ONAN MOTOR GENERATOR**

### **SERVICE INTERVALS**

For service intervals refer to the Maintenance Chart provided earlier in this section.

## **CHECKING OIL LEVEL**

Check the oil level daily, or at least every eight hours of operating time. Check more often on a new unit as oil consumption is generally higher until piston rings seat properly.

## CHANGING OIL

Initial oil change should be made after the first 25 hours of operation; change every 50 to 100 hours after that. If operating in extremely dusty or cold weather conditions, change oil more frequently.

The 4KW Model has an oil capacity of 3 quarts, 3 1/2 quarts if replacing oil filter.

The 6KW Model has an oil capacity of 4 quarts; 4 1/2 quarts if replacing oil filter.

Do not mix brands or grades of motor oil. Use a good quality oil with the designation SE/CC. If necessary to add oil between changes, use the same brand and grade of oil.

Use the following chart as a guide for the proper oil according to temperature ranges:

Temperature	Recommended Oil
Above 30°F. 0°F. to 30°F. Below 0°F.	SAE 30 SAE 5W30 or 10W40 SAE 5W30

**NOTE:** Fill engine with oil through dipstick tube.

The oil drain plug is located on the bottom side of the engine oil pan. Unit must be pulled out on its slide rail to gain access.

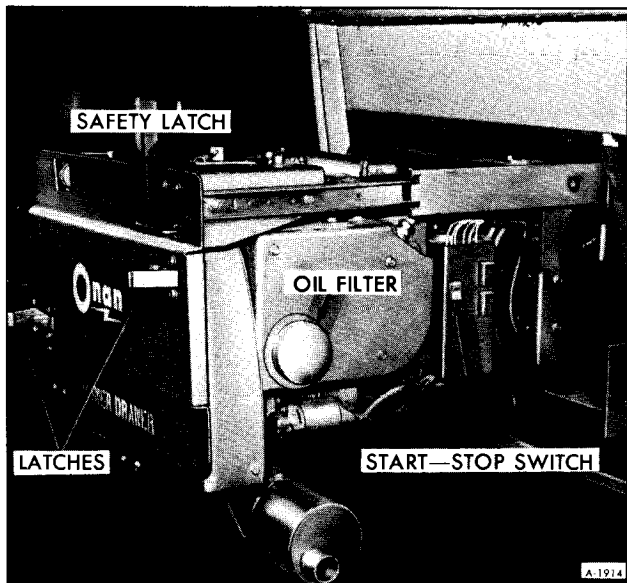

Figure 3—Onan Motor Generator

## OIL FILTER (FIGURE 3)

Change the crankcase oil filter at least every 200 hours on the 4KW Model and every 100 hours on the 6KW Model. The filter is located on the right side of the unit (facing the compartment). Remove by turning counterclockwise with a filter wrench. Before installing new filter, coat the gasket on the filter's base with a light film of new oil. Install by turning clockwise until a light friction is noted, then turn an additional 1/4 to 1/2 turn.

**CAUTION:** Do not over-tighten filter as damage may occur to rubber gasket which will cause filter to leak. Be sure to install sealing ring around filter; this ring is an air seal to prevent cooling air loss.

## KOHLER MOTOR GENERATOR

### SERVICE INTERVALS

For service intervals refer to the Maintenance Chart earlier in this section.

### CRANKCASE OIL (FIGURE 4)

The oil level should be checked every time the unit is operated. The unit must not be operated if the oil level is above the "F" mark, or below the "L" mark on the dipstick. The oil level should not be checked when the unit is running as oil may splash from the dipstick opening.

Use a good quality detergent oil that meets the A.P.I. (American Petroleum Institute) Service Designation SE/CC. use the proper SAE oil for expected temperature conditions.

Temperature	Recommended Oil
Above 30°F. 0°F. to 30°F. Below 0°F.	SAE 30 SAE 10W-30 SAE 5W-20

**NOTE:** Fill engine through dipstick tube.

**IMPORTANT:** The initial oil change should be at the end of 5 operational hours.

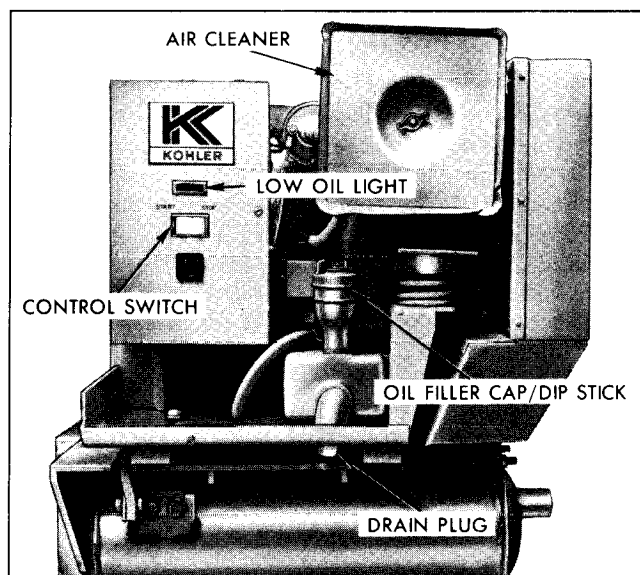

Figure 4-Kohler Motor Generator

The oil change interval is every 50 operational hours, or every 6 months, whichever comes first. If possible, change the oil while it is hot. The crankcase capacity is 3 quarts. The oil drain plug is located under the oil filler cap shown in Figure 4.



# SECTION 24B LIVING AREA ELECTRICAL SYSTEM

Contents of this section are listed below:

SUBJECT	PAGE NO.
General Information .....	24B-1
Electrical Compartment .....	24B-1
External Power .....	24B-3
Living Area Lighting System .....	24B-4
120-Volt Electrical System .....	24B-4
Monitor Panel .....	24B-6
Specifications .....	24B-8

## GENERAL INFORMATION

The Motor Home living area electrical system is designed for utmost convenience. It is capable of supplying the vehicle with power from at least two sources (three, if equipped with a motor generator), these are the batteries or external power.

All electrical components except the water heater, the roof mounted air conditioner (if equipped), and the plug receptacles, are powered by the 12 volt living area battery which is automatically charged each time the vehicle's engine is running.

In addition, the vehicle may be plugged into a 120-volt external power source which will supply 120-volt power throughout the living area., power all 12-volt components through a power converter, and

charge the living area battery.

If the Motor Home is equipped with a motor generator, the vehicle will be supplied with 120-volt and 12-volt power throughout the living area, and recharge the living area battery, any time the motor generator is running.

Both the 12-volt DC and 120-volt AC circuits in the Motor Home living area are designed to be protected by a series of fuses and circuit breakers. The 12-volt living area circuits are protected by automotive-type fuses, and the 120-volt circuits are protected by circuit breakers like those found in modern homes.

## ELECTRICAL COMPARTMENT (FIGURE 1)

### 12-VOLT LIVING AREA FUSE BLOCK

The 12-volt living area fuse block is located in the electrical compartment, next to the hall closet, along with power converter and main circuit breaker panel. In the event of an overloaded circuit, the cause should be corrected and a new fuse of the same capacity installed. For explanation of 12-volt fuse block number code, refer to Figure 2 or the Specifications at the end of this section.

### 120-VOLT CIRCUIT BREAKER PANEL

The main circuit breaker panel, also located in

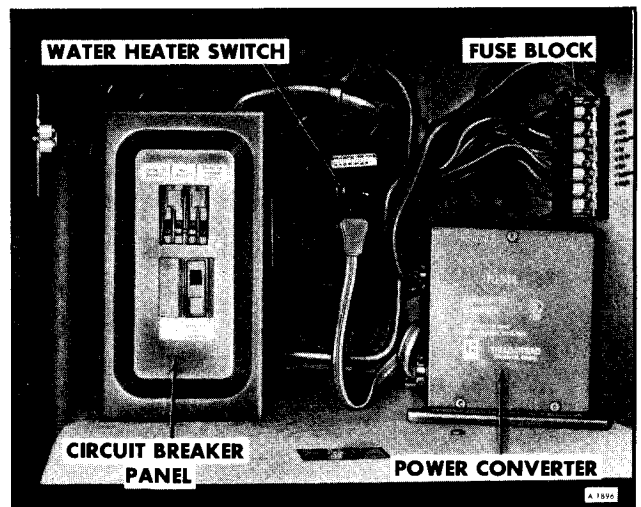
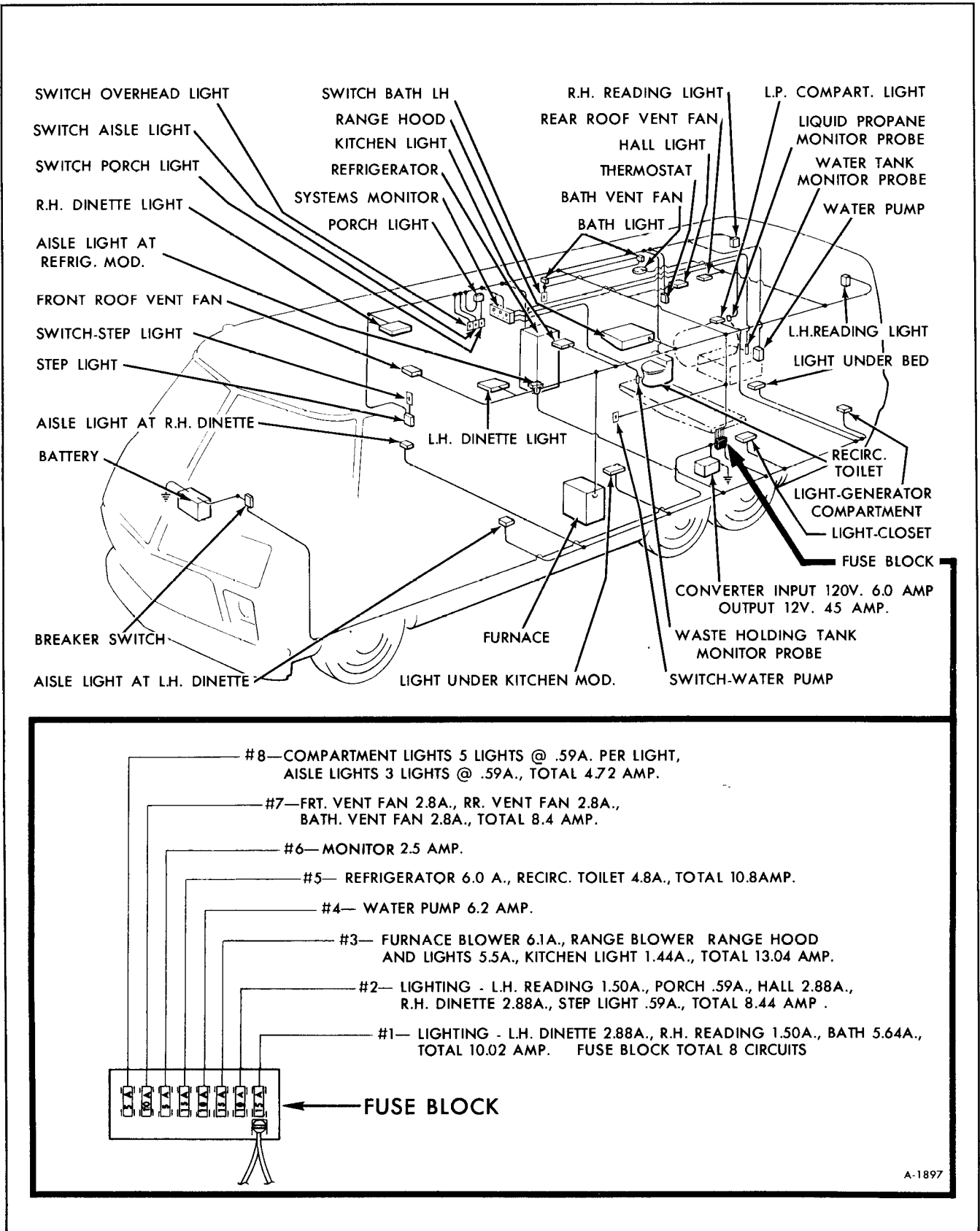

Figure 1-Living Area Electrical Compartment

24B-2 LIVING AREA ELECTRICAL



A-1897

Figure 2—Living Area 12-Volt DC Electrical System (Typical)

the living area electrical compartment, contains circuit breakers to protect the 120-volt Motor Home circuits from overloads. These circuit breakers are designed to snap to the "OFF" position in the event of an overloaded 120-volt circuit. Once the cause of the overload is corrected the circuit breaker switch may be moved back to the "ON" position.

## 120-VOLT to 12-VOLT CONVERTER AND BATTERY CHARGER

The Motor Home is equipped with either a 30 amp or 45 amp 120-volt to 12-volt power converter. Its function is to take a portion of the 120-volt current, that is received when the vehicle is plugged into an external power source, or when the motor generator is running and change it to 12-volts which powers much of the Motor Home. It will also charge the auxiliary (living area) battery any time 120-volt current is being received. The unit is located in the living area electrical compartment, next to the hall closet.

All switching operations in the power converter are automatic. It should remain plugged in at all times.

The power converter, requires no periodic maintenance but care must be taken to ensure a

proper flow of air through and around the unit. Do not set objects close to or on top of it. Do not let the power converter get wet and keep it as clean as possible to help assure long life. The unit could be cleaned with air pressure if necessary.

The power converter has no moving parts, but should you suspect that the unit is not functioning properly, remove it from the electrical compartment, plug it into a reliable power source and measure the voltage at the converter output with a voltmeter. If you don't get a reading of approximately 14 volts, replace the unit with a new one. Note that the input to converter should be 120 volts.

## WATER HEATER SWITCH

An "ON OFF" switch for the water heater is located in the living area electrical compartment. The switch is located in this compartment to prevent the possible hazard of operating the switch with wet hands; i.e., trying to operate the switch after starting to wash or shower.

**CAUTION:** *Do not operate water heater unless there is water in the living area water system. If unit is operated without water this will result in damage to the heating element.*

**NOTE:** For details on the water heater, refer to Living Area Water System, Section 24J.

# EXTERNAL POWER

## GENERAL INFORMATION

The external utilities compartment located in the left side of the Motor Home contains the 25 foot power cord used for external power connections (See figure 3).

To make an external power connection, remove the cord from the compartment and plug it into a suitable power receptacle. All internal switching will take place automatically. When disconnecting from an external power source the power cord should be plugged into the motor generator receptacle within the external utilities compartment. This connects the motor generator to the Motor Home electrical system. If the vehicle is not equipped with a motor generator simply coil the power cord neatly within the external utilities compartment.

The Motor Home's external power cord contains two 120-volt circuits, each rated to carry 20 amperes. The electrical connection to be used must be suitable for these requirements. If the receptacle is designed to mate with the prongs on the power cord plug, the

electrical connection can be expected to CARRY RATED LOAD. It is recommended that the power cord not be plugged in if the receptacle is not designed for the plug. In this event use the optional motor generator.

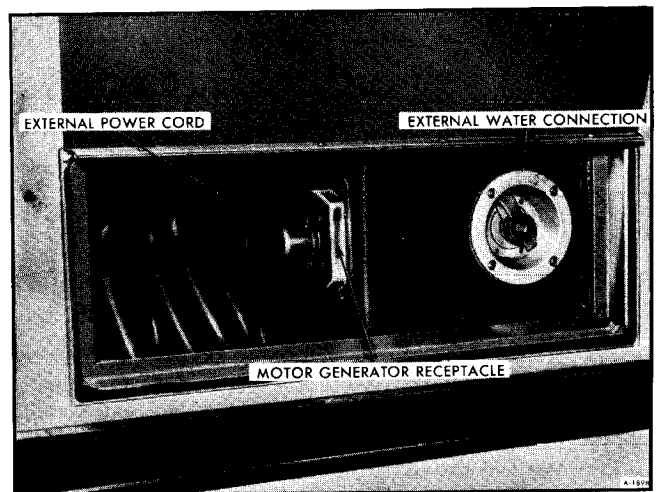

Figure 3—External Utilities Compartment



**CAUTION:** *If the available power supply is other than 120/240 volt, 60 cycle rating, or is not properly grounded, it is essential that no attempt be made to plug in. The Motor Home's electrical system is not designed for such electrical systems and connection could result in serious personal injury or property damage.*

## CORD REPLACEMENT

Should it ever become necessary to replace the external power cord for any reason, refer to the 120-volt wiring diagram later in this manual. Care should be taken that the new cord is properly wired to panel.

## LIVING AREA LIGHTING SYSTEM

All the lighting throughout the Motor Home is on the 12-volt system and is powered by either the living area battery, the power converter when the vehicle is connected to an external power source, or when the motor generator is running (if the vehicle is so equipped). Some of these lights contain a three-way switch which allows a choice in the amount of light given off. The switches to these lights are located on the light fixture itself.

A panel of light switches is located near the entrance door. These switches operate the porch light, the kitchen sink light and the aisle lights (if vehicle is so equipped) (figure 4).

A step light near the entrance door is designed to automatically come on when the entrance door is opened.

Should any of these lights fail to operate first make sure that the electrical source is sufficient, then check the fuse, next replace the bulb itself, and finally if there is still no operation check the wiring and fixture.

For light bulb specifications or for current draw

ratings refer to Specifications at the end of this section.

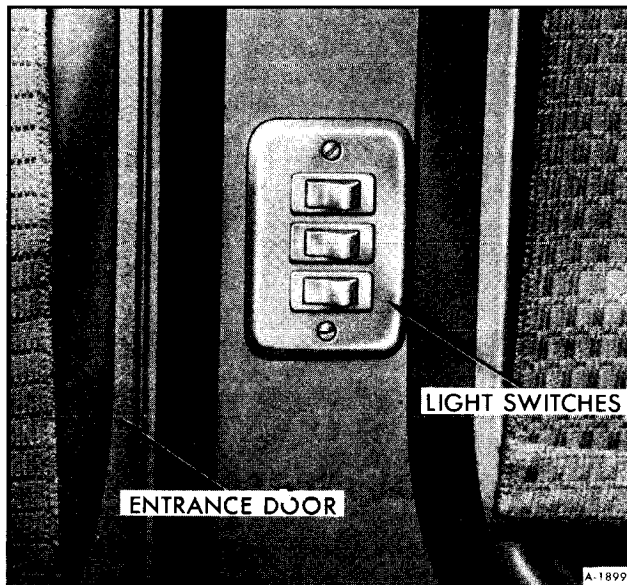

Figure 4—Light Switch Panel

## 120-VOLT AC ELECTRICAL SYSTEM

The Motor Home living area is equipped with 120-volt wiring and duplex receptacles like those found in modern homes. These receptacles, the power converter and the water heater are operational whenever the Motor Home is connected to an external power source or the motor generator is operating. If the Motor Home is equipped with a roof mounted

air conditioner or a vacuum cleaner these will also be run by the 120-volt system.

For wiring information, location, and specifications refer to Figure 5 and Specifications at the end of this section.

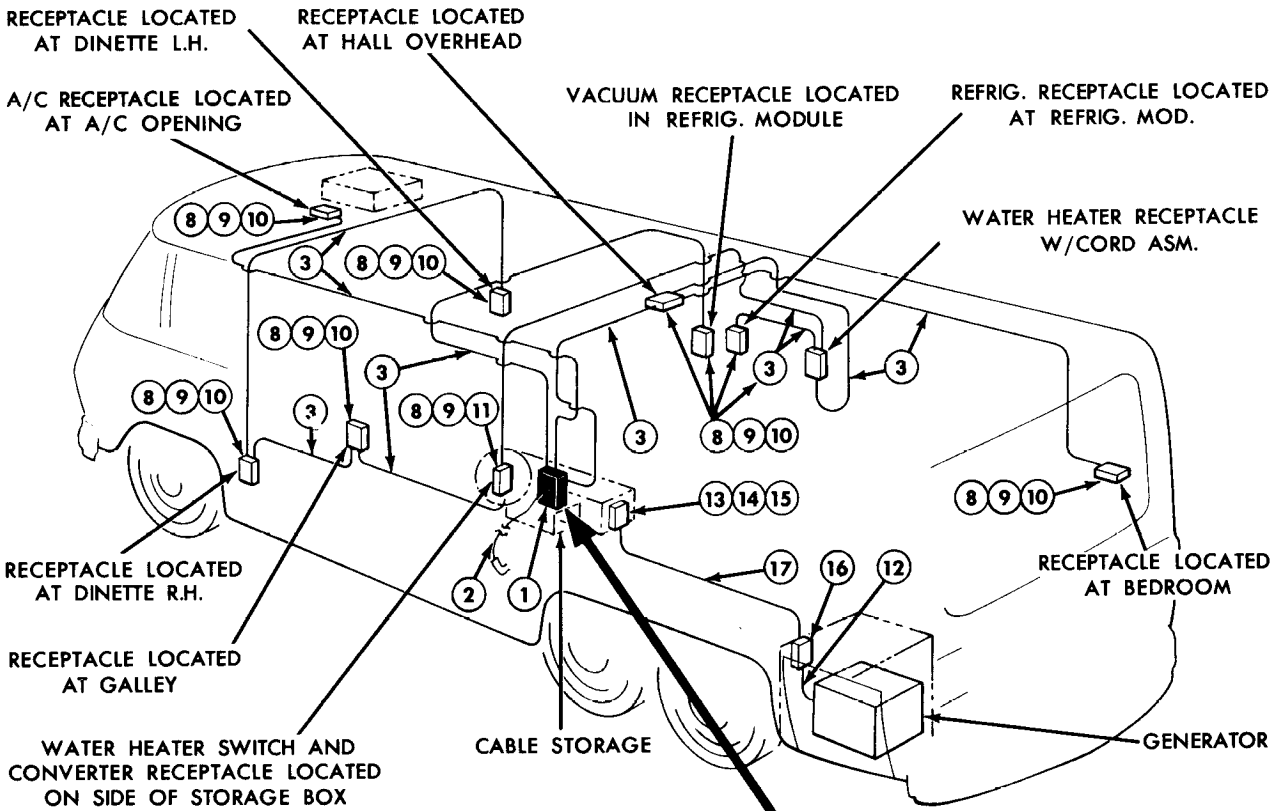

ITEM NO.	PART NAME
1	CIRCUIT BREAKER PANEL
2	#8-4 WIRE CORD TYPE "SO" W/PLUG
3	WIRE 12/2 W/GROUND WIRE
4	40 AMP BREAKER
5	20 AMP BREAKER
6	CABLE CONNECTOR
7	#8 COPPER GROUND WIRE
8	OUTLET BOX
9	DUPLEX RECEPTACLE
10	OUTLET PLATE
11	SWITCH & RECEPTACLE
12	#8-4 WIRE CORD TYPE "SO"
13	3 POLE 4 WIRE RECEPTACLE
14	OUTLET BOX
15	OUTLET PLATE
16	"J" BOX
17	#8-4 WIRE CORD ROMEX

CIRCUIT BREAKER PANEL			
CIRCUIT #1	CIRCUIT #2	CIRCUIT #3	CIRCUIT #4
CONVERTER RECEPT.	HALL OVER RECEPT.	AIR COND. RECEPT.	VACUUM RECEPT.
GALLY RECEPT.	BEDROOM RECEPT.		
L.H. DINETTE RECEPT.	BATH & WATER HEAT. RECEPT.		
R.H. DINETTE RECEPT.			

A-1900

Figure 5-120-Volt AC Electrical System (Typical)

## MONITOR PANEL (FIGURE 6)

### DESCRIPTION

The optional Motor Home Monitor Panel is a series of four gauges located at eye level in the living area. Included are:

- **LP GAS** – This gauge is designed to indicate the amount of liquid petroleum gas remaining in the tank.

- **BATTERY VOLTS** – Indicates living area battery voltage. During operation, the indicator should remain in the center segment of the dial to indicate normal battery condition. If the indicator shows less than 11-volts, an under-charge condition exists in the living area battery and a recharge is required.

- **WATER TANK** – This gauge is designed to indicate the amount of water remaining in the living area water tank.

- **HOLDING TANK** – This is designed to indicate content level in the holding tank. Never allow this gauge to reach the “FULL” mark. If the holding tank is overfilled the overflow will back up through the bathroom shower drain.

These gauges are activated by a “ROCKER” switch located on the face of the panel. This switch

has three positions; “ON,” “OFF,” and “MOMENTARY ON.” An indicator light glows when gauges are operating.

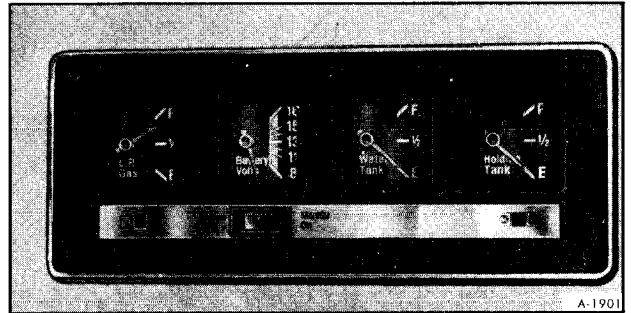

Figure 6—Monitor Panel

### TROUBLE DIAGNOSIS

#### TANK GAUGES

Since the L.P. Gas, the Water Tank, and the Holding Tank gauges all operate on the same principle the following trouble diagnosis will pertain to any of the three gauges.

## MONITOR PANEL GAUGE DIAGNOSIS CHART

Complaint	Possible Cause	Correction
Gauge reads “E” all the time.	<ol style="list-style-type: none"> <li>1. Circuit grounded between sending unit and tank.</li> <li>2. Open circuit between ground terminal on gauge and ground.</li> <li>3. Needle rubbing on face of gauge.</li> <li>4. Tank float hang-up.</li> </ol>	<ol style="list-style-type: none"> <li>1. Insulate grounded circuit.</li> <li>2. Clean contact between gauge and ground.</li> <li>3. Reposition needle.</li> <li>4. Free binding float or install new tank unit.*</li> </ol>
Gauge reads “F” all the time.	<ol style="list-style-type: none"> <li>1. Open circuit between sending unit and tank.</li> <li>2. Open circuit between tank unit slider resistor and ground.</li> <li>3. Needle rubbing on face of gauge.</li> <li>4. Tank float hang-up.</li> </ol>	<ol style="list-style-type: none"> <li>1. Clean terminals or repair wires.</li> <li>2. Install new tank unit.*</li> <li>3. Reposition needle.</li> <li>4. Free binding float or install new tank unit.*</li> </ol>

Complaint	Possible Cause	Correction
Erratic reading	1. Loose connection anywhere in circuit.	1. Inspect and if necessary, clean and tighten all connections in circuit.
Needle does not move	1. Lack of 12-volt supply to gauge. 2. Needle rubbing on face of gauge. 3. Tank float hang-up.	1. Check power supply, fuse, and wiring. 2. Reposition needle. 3. Free binding float or install new tank unit.*
Gauge gives other than correct reading.	1. Tank float hang-up or malfunction in sending unit. 2. Malfunction in gauge.	1. Free binding float or install new tank unit.* 2. Replace gauge.

\* Electrical power must be off before removing tank sending unit, otherwise full voltage may destroy unit or possibly ignite L.P.G. vapor. Disconnect battery ground cables and remove monitor panel fuse.

### “BATTERY VOLTS” GAUGE

If “Battery Volts” gauge fails to operate properly the trouble can usually be quickly isolated. If the other gauges of the monitor panel operate but the “Battery Volts” gauge is inoperative the gauge is at fault and should be replaced. If none of the gauges of the monitor panel operate the trouble is in the power supply...check supply, fuse, and wiring.

### GAUGE REPLACEMENT (FIGURE 7)

#### REMOVAL

To remove any of the four gauges in the monitor panel:

1. Remove monitor panel fuse and disconnect battery ground cables. Pull the complete monitor panel assembly out of wall mounting (it is held in by spring clips).

2. Disconnect wiring harness from rear of panel.

3. With monitor panel at the bench remove the four screws holding bezel on panel.

4. Remove the two screws holding defective gauge in case and carefully remove gauge.

### INSTALLATION

1. Carefully press gauge into position and secure with two screws.

2. Replace monitor panel bezel and secure with four screws.

3. Connect wiring harness at rear of panel.

4. Push monitor panel into position.

5. Reconnect electrical power and check gauge operation.

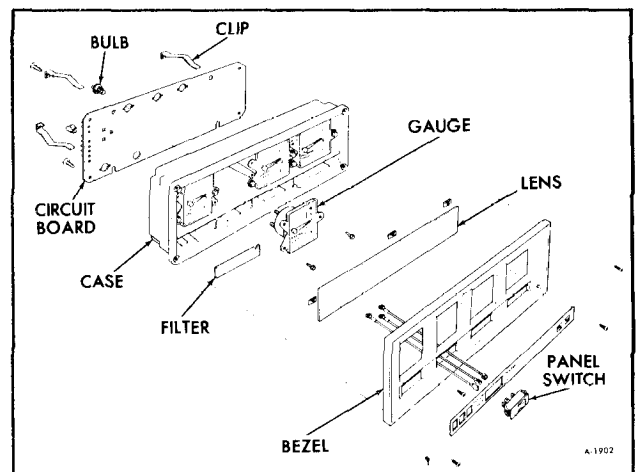

Figure 7-Monitor Panel Components

## SPECIFICATIONS

### LIVING AREA 12-VOLT SYSTEM FUSES

The following are located in the fuse block in the living area electrical compartment, near the hall closet. Do not use fuses of higher amperage rating than those specified below, or damage may result.

Usage	Number on Fuse Block	Fuse Type	Wire Color
L.H. Dinette Light R.H. Reading Light Bath Light	1	AGC-15	Red
L.H. Reading Light Porch Light Hall Light R.H. Dinette Light Step Light	2	AGC-10	Black
Furnace Blower Range Hood and Lights Kitchen Light	3	AGC-15	Yellow
Water Pump	4	AGC-10	Light Blue
Refrigerator Recir. Toilet	5	AGC-15	Light Blue
Monitor	6	AGC-5	Green
Roof Vent Fans	7	AGC-10	Black
Compartment Lights Aisle Lights	8	AGC-5	Black

## LIGHT BULB SPECIFICATIONS (LIVING AREA)

Usage	Quantity	Bulb. No.
R.H. Dinette Light	2	1141
L.H. Dinette Light	2	1141
Kitchen Light	2	1141
Hall Light	2	1141
Porch Light	1	1141
Compartment Lights	5	1141
Range Hood Lights	2	1156
Rear Compartment Reading Lights	2	1383
Bathroom Lights	6	93
Aisle Lights	3	68
Step Light	1	68

## 120-VOLT SYSTEM CURRENT RATING

Water Heater .....	10.0 Amp.
Power Converter .....	6.8 Amp.
Mark IV Roof Mount Air Conditioner .....	16.5 Amp.
Vacuum Cleaner .....	7.0 Amp.

## 12-VOLT LIVING AREA COMPONENTS CURRENT RATING

R.H. Dinette Light .....	2.88 Amp.
L.H. Dinette Light .....	2.88 Amp.
Hall Light .....	2.88 Amp.
R.H. Reading Light.....	1.50 Amp.
L.H. Reading Light.....	1.50 Amp.
Kitchen Light .....	1.44 Amp.
Aisle Lights (Per Light) .....	0.59 Amp.
Compartment Lights (Per Light) .....	0.59 Amp.
Porch Light .....	0.59 Amp.
Step Light.....	0.59 Amp.
Bath Room Lights.....	5.64 Amps.
Range Hood Vent Fan and Lights .....	5.50 Amps.
Furnace Blower .....	6.1 Amp.
Water Pump.....	6.2 Amp.
All-Electric Refrigerator.....	6.0 Amp.
Gas/Electric Refrigerator .....	20.0 Amp
Recirculating Toilet.....	4.8 Amp.
Monitor Panel .....	2.5 Amp.
Front Vent Fan .....	2.8 Amp.
Rear Vent Fan.....	2.8 Amp.
Bath Vent Fan.....	2.8 Amp.



# SECTION 24C MOTOR GENERATOR

This section includes the following:

SUBJECT	PAGE NO.
Onan Motor Generator .....	24C- 1
Kohler Motor Generator.....	24C-52

## ONAN MOTOR GENERATOR

Contents of this sub-section are listed below:

SUBJECT	PAGE NO.
General Information .....	24C- 1
Onan Motor Generator Trouble Diagnosis .....	24C- 1
Motor Generator Replacement .....	24C- 8
Engine .....	24C-10
Oil System .....	24C-22
Fuel System .....	24C-23
Ignition and Battery Charging System .....	24C-27
Starting System .....	24C-31
AC Generator .....	24C-40
Controls .....	24C-45
Specifications .....	24C-47

## GENERAL INFORMATION

The Onan Motor Generator is powered by a two cylinder horizontally opposed gasoline engine. An automotive type starter is used on the unit. It is powered by 55 amp hour battery located in the compartment with the generator. A permanent magnet flywheel alternator and solid state voltage regulator-rectifier are used to charge the battery.

Lubrication is provided by a pressure oil system. A spin-on type oil filter is utilized.

The motor generator does not have a separate fuel supply. Fuel is drawn from the vehicle's main fuel tank. An electric fuel pump is used to supply the unit with gasoline.

## ONAN MOTOR GENERATOR TROUBLE DIAGNOSIS

## CONTROL SYSTEM TROUBLESHOOTING GUIDE

Each Probable Cause is numbered and has a short title. These numbers correspond to a corrective action, given on the following pages.

**NOTE:** Use the schematic wiring diagram (figure 80) to help trace problems.

<b>CONDITION</b> Cranks Slowly Cranks - No Start Fails to Crank Runs 3 - 4 Seconds Runs and Surges Fails to Run Does Not Stop Stops No Stop in Low Oil Low Charging Corrective Action										<b>CONTROL SYSTEM TROUBLESHOOTING GUIDE</b>		<b>PROBABLE CAUSE</b>	
•		•								1	Bad Battery Connection		
•		•								2	Low Battery - BT1		
•		•								3	Faulty Starter - B1		
	•	•								4	Faulty Start Solenoid - K1		
				•		•		•		5	Faulty Alternator - G1		
	•					•				6	Faulty Ign. - T1 Coil, S1 Points		
	•			•		•				7	Faulty Fuel Pump - E2		
			•			•	•			8	Faulty LOP Switch - S2		
	•			•						9	Faulty Choke - E1		
			•							10	Grounded LOP Circuit		
	•			•	•		•			11	Low or No Fuel		
			•				•			12	Low Oil Level		
								•		13	Faulty Regulator - VR1		
										14	<b>Printed Circuit Board Faults</b>		
	•			•			•			15	Fuse Out - F1		
	•			•						16	Faulty Disconnect Circuit		
					•					17	Faulty Stop Switch - S3		
	•	•		•						18	Faulty Contacts - K2		
	•									19	Faulty Relay - K3		
			•				•			20	Faulty LOP Circuit		

Control System Troubleshooting Guide

### CORRECTIVE ACTION TO TROUBLESHOOTING GUIDE

1. Clean and tighten all battery terminals. Check for loose wires and correct connections. See steps 2 and 3.

2. Check specific gravity. Recharge or replace battery if necessary. See Step 5.

3. Check starter brushes and/or substitute with a new starter. Replace if defective. See Step 4.

4. When cranking, check K1 coil voltage. There should be approximately 12V DC across terminals 11 (+) and 7 (-), 10 (+) and 1 (-), B1-S (+) and 1 (-) ground. If this voltage is not present at any of these terminals, replace start solenoid. Check condition 18 to eliminate PC board faults.

5. Measure AC voltage of alternator G1 during cranking. Approximately 6 volts AC should be present at terminals 8 and K1 battery terminal. If there is zero volts then check the wiring for a short circuit. If the alternator fails to charge when running at 1800 RPM, replace alternator; see Step 13 and preceding paragraph, *Charge Ammeter*.



6. Visually check ignition points to see if they are opening and closing. If not, adjust to engine specifications. Voltage to ground at the battery side of T1 coil should be 12 volts. At the ignition point side to ground, the voltage should be zero when the points are closed and 12 volts when the points are open.

7. Remove S lead on starter B1. Push start button then listen for fuel pump clicking. Next check by connecting fuel pump lead directly to +12V. If it does not operate, replace fuel pump. See Step 11 also.

8. With engine not running, voltage from terminal 11 to 12 should be 12 volts. With proper oil level, start and run engine; voltage from terminal 11-12 should drop to zero volts. If not, replace low oil pressure switch. See steps 10, 12 and 20.

9. Manually check choke arm for free movement to be sure it is not stuck in the open or closed position. Voltage at choke terminal, supplied by K1-I terminal should be 12 volts during cranking and drop to zero during run. See Step 4 to check choke supply voltage. If choke does not move at room temperature with 12 volts applied, replace.

10. Check oil pressure sensor wire for short to ground by visually tracking the wire routing under cover edges to S2 switch. Move wire to free space to correct problem. See Step 8.

11. Refill fuel tank.

12. Refill to proper oil level.

13. Insert an ammeter to measure charging current. It should be 8-10 amperes at 12 volts (1800 RPM - room temperature) then drop to zero amperes at 14-15 volts. If alternator is OK (Step 5) then replace regulator VRI.

14. All faults 16 thru 23 will be on the PC control board and should be checked with care. Control cover should be removed and relay covers can be removed to manually operate relay to confirm start and run functions.

15. Measure voltage at terminals 5 to GND. If not 12 volts, replace fuse.

16. Measure voltage across capacitor C1 terminals. During cranking, this should increase to approximately 6 volts and relay K2 should not be energized.

If voltage does not build up refer to Step 5 and also check CR1, C1 and R1. As engine starts, voltage should build up to 13 volts minimum and energize relay K2. If it does not, check coil (500 ohm).

17. When running, voltage at terminal 2 to 1 should be 10 volts. When stop switch is pushed this voltage should drop to zero. If it does not, replace switch.

18. During cranking, voltage from terminals 3 to 7 should be zero. When engine starts and runs this voltage should increase to 12 volts with start switch held in. If it does not increase to 12 volts, then these normally closed contacts are not opening and may be faulty. During cranking, voltage at terminals 6 to 1 should be 10 volts. When engine runs this voltage should increase to 12V. or above. If it does not increase, then K2 open contacts may not be closing. Replace K2 if faulty.

19. During start or run, 9 volts should be present at terminals 2 (+) and 1 (-) to energize K3. Check K2 contacts, CR5, CR7 and R2 for defects. If K3 does not pick up with 9V, replace K3.

Measure voltage from terminal 9 to 1 (-) when cranking. If fuse F1 is good but battery voltage is not present at terminal 9, replace K3, and/or check PC board.

20. With unit stopped, connect voltmeter to terminals 4 (+) and 1 (-), remove K2 relay cover and manually hold K2 contact closed. After a short time delay, the voltage at terminals 4 to 1 should decrease from 9 to 2 volts. Reset by releasing K2. If voltage does not appear at terminals 4-1 check R2, R3, R4, R5, R6, R7, C3, C4, Q1, CR6, CR7, and CR8. Replace defective part.

# ENGINE TROUBLE DIAGNOSIS

TROUBLE															GASOLINE ENGINE TROUBLESHOOTING GUIDE														
TROUBLE															CAUSE														
Backfire at Carburetor	Bearing Wear	Black Exhaust	Blue Exhaust	Burned Valves	Cranks Slowly	Cylinder Rod Wear	Engine Stops	Failure to Start	Governor Hunting	High Oil Pressure	Low Oil Pressure	Loss of Coolant (Water Cooled)	Mechanical Knocks	Misfiring	Overheating (Air Cooled)	Overheating (Water Cooled)	Piston Wear	Poor Compression	Ring Wear	Sticking Valves									
																				<b>STARTING SYSTEM</b>									
																					Loose or Corroded Battery Connection								
																					Low or Discharged Battery								
																					Faulty Starter								
																					Faulty Start Solenoid								
																				<b>IGNITION SYSTEM</b>									
																					Ignition Timing Wrong								
																					Wrong Spark Plug Gap								
																					Worn Points or Improper Gap Setting								
																					Bad Ignition Coil or Condenser								
																					Faulty Spark Plug Wires								
																				<b>FUEL SYSTEM</b>									
																					Out of Fuel - Check								
																					Lean Fuel Mixture - Readjust								
																					Rich Fuel Mixture or Choke Stuck								
																					Engine Flooded								
																					Poor Quality Fuel								
																					Dirty Carburetor								
																					Dirty Air Cleaner								
																					Dirty Fuel Filter								
																					Defective Fuel Pump								
																				<b>INTERNAL ENGINE</b>									
																					Wrong Valve Clearance								
																					Broken Valve Spring								
																					Valve or Valve Seal Leaking								
																					Piston Rings Worn or Broken								
																					Wrong Bearing Clearance								
																				<b>COOLING SYSTEM (AIR COOLED)</b>									
																					Poor Air Circulation								
																					Dirty or Oily Cooling Fins								
																					Blown Head Gasket								
																				<b>LUBRICATION SYSTEM</b>									
																					Relief Valve Stuck								
																					Faulty Oil Pump								
																					Dirty Oil or Filter								
																					Oil Too Light or Diluted								
																					Oil Level Low								
																					Oil Too Heavy								
																					Dirty Crankcase Breather Valve								
																				<b>THROTTLE AND GOVERNOR</b>									
																					Linkage Out of Adjustment								
																					Linkage Worn or Disconnected								
																					Governor Spring Sensitivity Too Great								
																					Linkage Binding								

## FUEL SYSTEM TROUBLE DIAGNOSIS

Problem	Possible Cause	Correction
Fuel leaks from carburetor when fuel shut-off is open.	1. Float level set too high.	1. With fuel bowl removed and carburetor inverted, set float parallel to bowl flange. (3/32" clearance)
	2. Dirt under inlet valve.	2. Remove inlet valve, clean seat by rinsing in clean fuel and blow off with compressed air.
	3. Bowl vent plugged.	3. Remove bowl and blow clean with compressed air.
	4. Collapsed float caused by blowing assembled carburetor with compressed air.	4. Replace float.
	5. Carburetor gummed from storage. Float stuck to screen.	5. Remove fuel bowl and clean.
Engine smokes and runs rich.	1. Dirty air filter.	1. Clean or replace.
	2. Improper adjustment.	2. Set idle & power needles at 1 turn open. After engine starts and runs, set for optimum performance.
	3. Nozzle boss gasket leaks. Engine runs with power needle seated.	3. Remove fuel bowl and replace gasket. Tighten bowl retainer securely.
	4. Air bleeds in carburetor plugged.	4. Remove fuel bowl, idle & power needles. Clean thoroughly with compressed air.
Engine runs lean.	1. Improper adjustment.	1. Set idle & power needles at 1 turn open. After engine starts and runs, set for optimum performance.
	2. Idle holes plugged. Dirt in fuel delivery channels.	2. Remove fuel bowl, idle & power needles. Clean thoroughly with compressed air.
	3. Float level set too low. Low level in fuel bowl.	3. With fuel bowl removed and carburetor inverted, set float parallel to bowl flange. (3/32" clearance)
	4. Fuel filter in electric fuel pump dirty.	4. Remove filter and replace.
	5. Fuel filter in fuel bowl plugged.	5. Remove fuel bowl. Invert bowl and tap on flat surface. Clean thoroughly and replace.

Problem	Possible Cause	Correction
Engine starts hard.	1. Improper adjustment.	1. Set idle & power needles at 1 turn open. After engine starts and runs, set for optimum performance.
	2. No fuel in carburetor.	2. Check carburetor drain valve. If no fuel in bowl clean tank filter and carburetor.
	3. Choke valve not closing.	3. Check controls for proper travel.
Governor Surge	1. Throttle shaft and valve binding.	1. Remove and replace shaft if worn. Clean carburetor body. Reassemble throttle shaft assembly into carburetor body as far as possible. Hold firmly in place in this position while assembling throttle valve. Make certain valve does not bind in throttle bore when opening and closing throttle.
	2. Lean carburetion.	2. Adjust carburetor.

## GENERATOR TROUBLE DIAGNOSIS

Problem	Possible Cause	Correction
No AC output voltage.	1. Blown fuse or circuit breaker.	1. Replace fuse or reset breaker and look for cause.
	2. Disconnected wire or lead on brushes, bridge rectifier or reactor assembly.	2. Reconnect wire or wires.
	3. Brushes not making contact with collector rings.	3. Check brush springs for free movement or brushes which may be excessively worn.
	4. Open, grounded or short circuit in field or armature winding.	4. Test with series test lamp and repair or replace as necessary.
	5. Defective bridge rectifier assembly.	5. Test with ohmmeter and replace if defective.
	6. Bridge rectifier assembly installed wrong in its case.	6. Reinstall making sure marks on case and rectifier match.

Problem	Possible Cause	Correction
Lights flicker inter- mittently.	1. Loose or broken lead/ leads in generator.	1. Repair broken lead or reconnect loose lead.
	2. Brushes stuck in holder.	2. Clean or replace brush holder.
Low AC output voltage.	1. External short circuit on line.	1. Locate and eliminate short cir- cuit problem.
	2. Generator Overloaded.	2. Remove part of load.
	3. One defective recti- fier in bridge.	3. Test with ohmmeter and replace if defective.
	4. Shorted or grounded circuit in field or arma- ture winding.	4. Test with series test lamp or ohmmeter and replace if defective.
	5. Engine not running properly causing generator to slow down.	5. Refer to Engine Troubleshooting guide.
Noisy generator.	1. Defective bearing in end bell.	1. Replace bearing.
Generator overheats	1. Generator overloaded.	1. Remove part of load.
	2. Windings and parts covered with oil or dirt.	2. Clean generator.
	3. Air intake restricted or incoming air too hot.	3. Take necessary steps to allow for proper cooling.
	4. Shorted, open or grounded circuit in arma- ture or field windings.	4. Test with ohmmeter or series test lamp and replace if defective
	5. Air seals are damaged or missing.	5. Replace air seals or tape over the air leak.
AC output voltage high with no load connected and generator running at 1800 rpm.	1. Compounding reactor defective.	1. Remove, test and replace.

# MOTOR GENERATOR REPLACEMENT

## REMOVAL (MODEL 230)

1. Open access door and support in this position.
2. Slide unit out of compartment.
3. Disconnect neg. terminal on battery.
4. Install lifting eye in manifold on top of unit. A 3/8-16 threaded hole is provided in the manifold for this purpose.
5. Attach a suitable lifting device into lifting eye, and remove slack.
6. Remove bolts holding ends of sliding arm to generator as shown in Figure 1.
7. Remove mounting fasteners from rear mount (figure 2).
8. Remove circuit breaker bracket from its mounting.
9. Disconnect fuel line and all electrical leads.
10. Remove unit from its slide rails and place on a suitable bench or stand.

## INSTALLATION (MODEL 230)

1. Extend mounting slides to their full position.

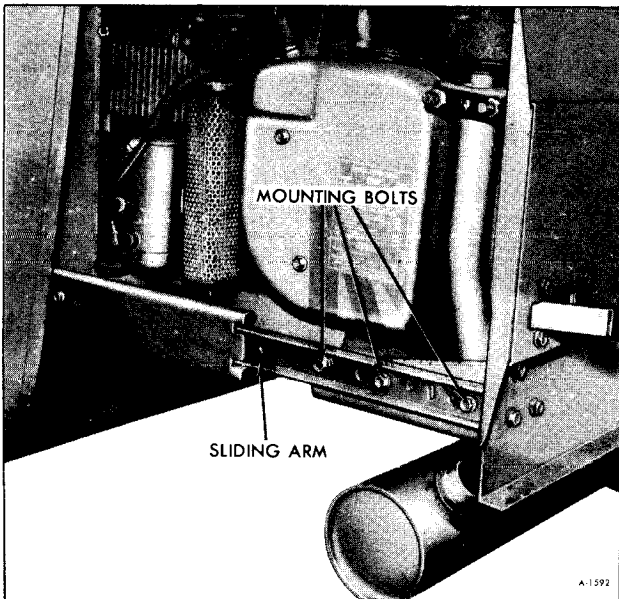

Figure 1—Disconnecting Sliding Arm

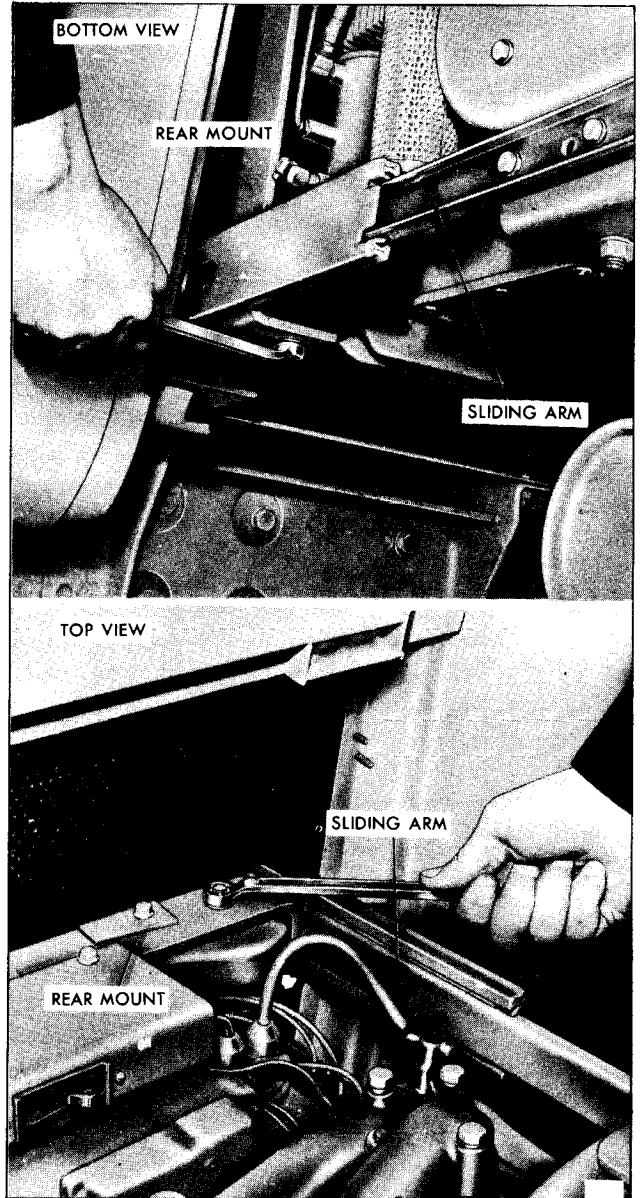

Figure 2—Disconnecting Rear Mounts

2. Supporting the unit with a suitable hoist, position it in the slide rails.
3. Connect fuel line and all electrical leads.
4. Install circuit breaker on rear mounting bracket.
5. Install rear mounting fasteners as shown in Figure 2.
6. Install mounting bolts to slides as shown in Figure 1.

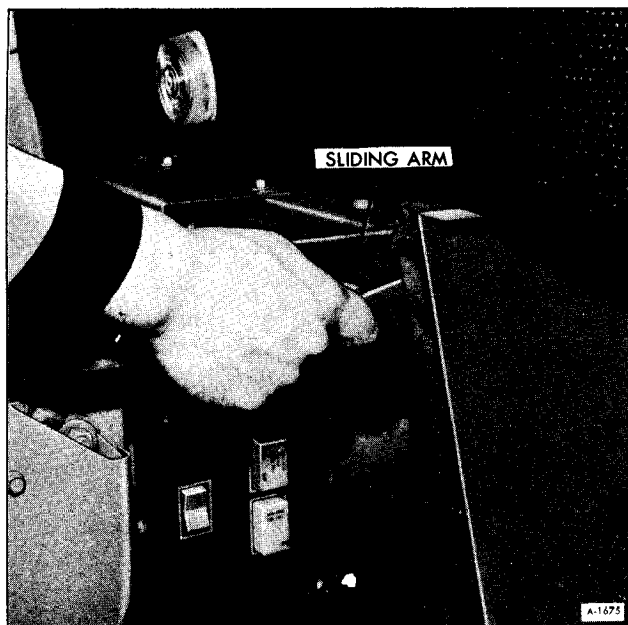

Figure 3—Disconnecting Sliding Arm (6KW)

7. Remove hoist and lifting eye.

## REMOVAL (MODEL 260)

1. Open access door and support in this position.
2. Slide unit out of compartment.
3. Disconnect ground cable (-) at battery.
4. Install lifting eye in manifold on top of unit. A 3/8-16 threaded hole is provided in the manifold for this purpose.

5. Attach a suitable lifting device into lifting eye, and remove slack.

6. Remove bolts from both sliding arms (figures 3 and 4).

**NOTE:** The bolts on the 4KW motor generator are readily accessible, as shown in Figure 4, whereas the mounting of the 6KW unit requires one of the bolts to be removed as shown in Figure 3.

7. Disconnect fuel lines and all electrical leads.
8. Remove unit from its slide rail and place on a suitable bench or stand.

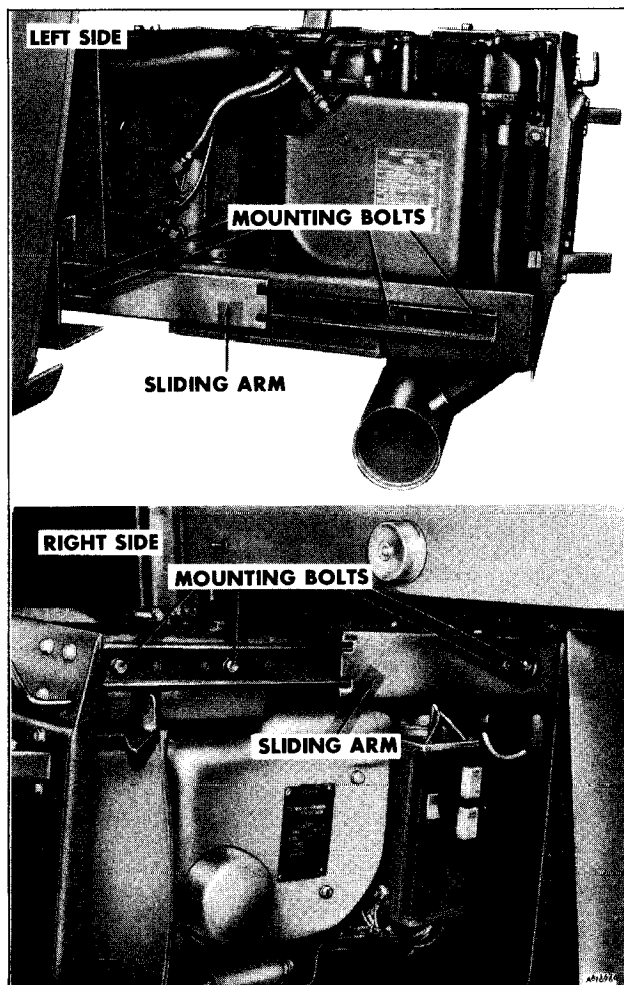

Figure 4—Disconnecting Sliding Arms (4KW)

## INSTALLATION (MODEL 260)

1. Extend slide rails to their full extended position.
2. Supporting the unit with a suitable hoist, position it in the slide rails.
3. Connect fuel line and all electrical wiring.
4. Install mounting bolts in slide rails as shown in Figures 3 and 4.
5. Remove hoist and lifting eye.

# ENGINE

## ENGINE OVERHAUL

The following steps serve only as a guide, when overhauling the engine.

Specific details on individual engine components are covered later in this section.

## DISASSEMBLY

1. Drain crankcase oil.
  2. Disconnect all exhaust lines, fuel lines and electrical wires (tag all electrical wires).
  3. Remove engine from its slide rails and mountings and place on a suitable bench or work stand.
  4. Remove all housings, shrouds, mounts, air cleaner, control box, etc.
- NOTE:** When removing generator and control box, tag all wires according to their respective locations.
5. Remove flywheel, using a puller or pry-bar method.
  6. Remove flywheel alternator stator.
  7. Remove the gear cover, being careful to protect the oil seal from keyway damage.
  8. Remove the crank gear, using a gear puller and ring.
  9. Remove fuel pump, oil filter, starter, carburetor, fuel lines, spark plugs, etc.
  10. Remove breaker box.
  11. Remove oil base, oil pump and cylinder heads.
  12. Remove valves, springs, rocker arm, lifters, etc.
  13. Remove camshaft and gear assembly.
  14. Remove connecting rods, pistons and bearings.
  15. Remove rear bearing plate.
  16. Remove crankshaft.

17. Remove front main bearing.

**NOTE:** Keep all parts in their respective orders. Keep valve assemblies together. Return rod caps to their respective pistons. Analyze the reasons for parts failure.

## ASSEMBLY

Observe proper clearances throughout the engine. Use a torque wrench to assure proper tightness. Coat the internal engine parts with SAE 30 oil as they are assembled. After the internal engine parts are assembled, the engine should turn over by hand freely.

1. Use the proper bearing driver to install front main bearing after coating it with a light film of oil.
2. Insert rear main bearing in rear bearing plate.
3. Install crankshaft and rear bearing plate.
4. Install connecting rods, pistons and bearings.
5. Install camshaft and gear.
6. Install valve assemblies.
7. Install oil pump, oil base and cylinder heads.
8. Install breaker box.
9. Install fuel pump, oil filter, starter, generator, carburetor, fuel lines, spark plugs, etc.
10. Install crank gear, aligning crank gear mark with camshaft.
11. Install gear cover and oil seal.
12. Install flywheel alternator stator.
13. Install flywheel.
14. Install all housings, air cleaner, control box, etc.
15. Reinstall power plant in vehicle, making proper fuel, battery, electrical and exhaust connections.
16. Fill crankcase with oil.
17. Start engine.



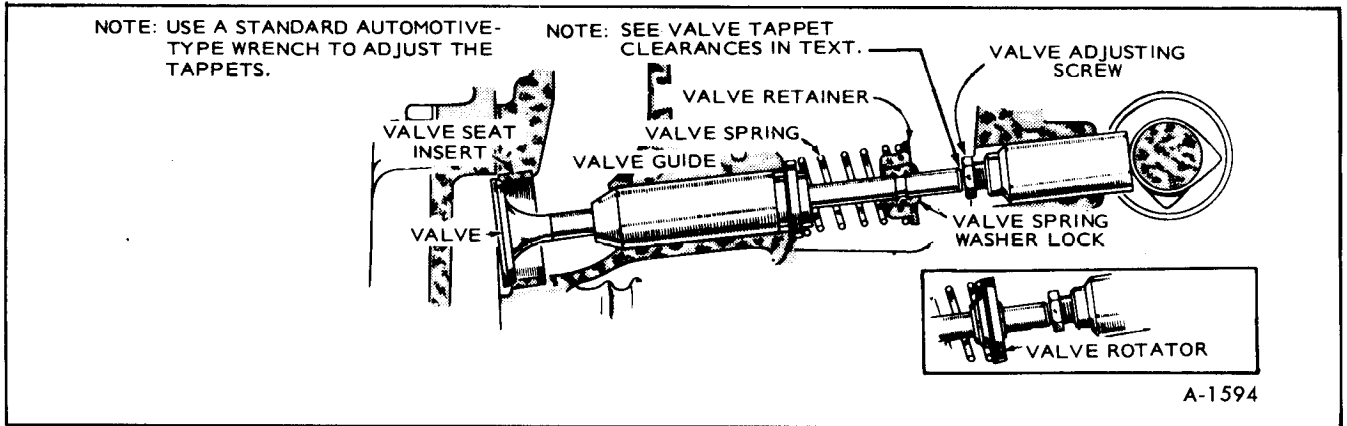

Figure 5-Valve System

- 18. Check oil pressure.
- 19. Run engine approximately 15 minutes to bring up to operating temperature.
- 20. Check for oil leaks, electrical connections, fuel lines and exhaust connections.

should be ground with a 45° stone and the width of the seat band should be 1/32" to 3/64" wide. Grind only enough to assure proper seating.

Remove all grinding compound from engine parts and place each valve in its proper location. Make pencil marks at intervals across the valve face and observe if the marks rub off uniformly when the valve is rotated part of a turn against the seat.

### VALVE SYSTEM FIGURE 5

Properly seated valves are essential to good engine performance. The aluminum cylinder heads are removable for valve servicing. Do not use a pry bar to loosen the cylinder head; rap sharply on the edge with a soft faced hammer, taking care not to break any cooling fins. A conventional type valve spring lifter may be used when removing the valve spring locks, which are of the split type. Clean all carbon deposits from the cylinder heads, piston tops, valves, guides, etc. If a valve face is burned or warped, or the stem worn, install a new valve.

Valve locks are split, tapered typed, the smaller diameter of which must face toward the valve head. Tappets are also replaceable from the valve chamber, after first removing the valve assemblies.

The valve *face* angle is 44°. The valve *seat* angle is 45° as shown in Figure 6. This 1° interference angle results in a sharp seating surface between the valve and the top of the valve seat. The interference angle method of grinding valves minimizes face deposits and lengthens valve life.

**CAUTION:** *The valves should not be hand lapped, because the sharp contact may be destroyed. This is especially important where stellite faced valves and seats are used.*

### TAPPET ADJUSTMENT (FIGURE 7)

The engine is equipped with adjustable valve tap-

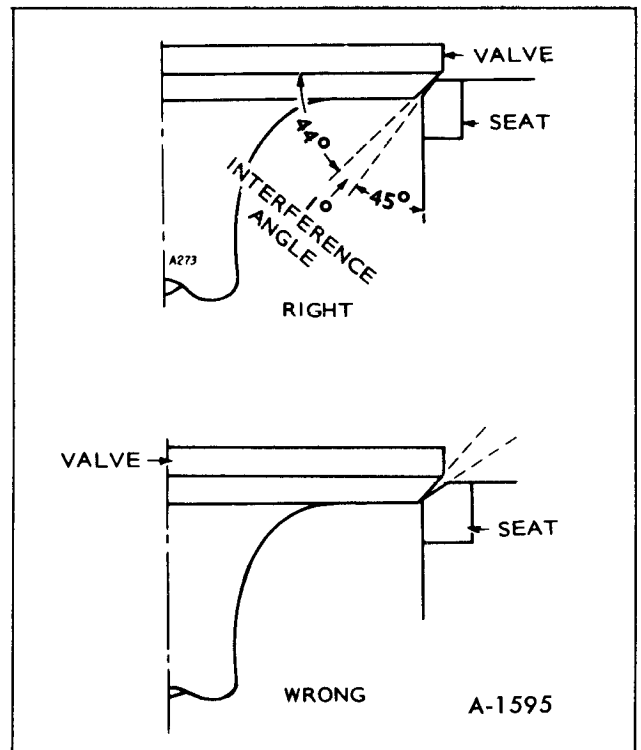

Figure 6-Valve Interference Angle

Valve faces should be finished to 44°. Valve seats

pets. The valve tappet clearance should be checked and adjusted, when necessary. Adjust the valve clearance only when engine is at ambient temperature. Proceed as follows:

1. Remove all parts necessary to gain access to valve tappets.

2. Remove spark plugs to ease the task of turning the engine over by hand.

3. Use the engine flywheel to turn the engine over slowly by hand until the left hand intake valve opens and closes. Continue turning the flywheel until the TC mark is on the top and lined up with the TC mark on the gear cover. Both valves should be closed. This should place the left hand piston at the top of its compression stroke, the position it must be in to get proper valve adjustment for the left cylinder.

4. For the intake valve, a .003" thickness gauge should just pass between valve stem and tappet.

5. For the exhaust valve, a .010" thickness gauge (.012" on the 6KW) should just pass between valve stem and tappet.

6. To correct the valve clearance, use a 7/16" open end wrench to turn the adjusting screw to obtain the correct clearance. The screw is self-locking and will stay where it is set. A 9/16" open end wrench is required to hold the tappet while turning the adjusting screw.

7. To adjust valves on the right hand cylinder-turn engine one complete revolution and again line up mark on the flywheel and the TC mark on the gear cover. Then follow adjustment procedure given for left hand cylinder.

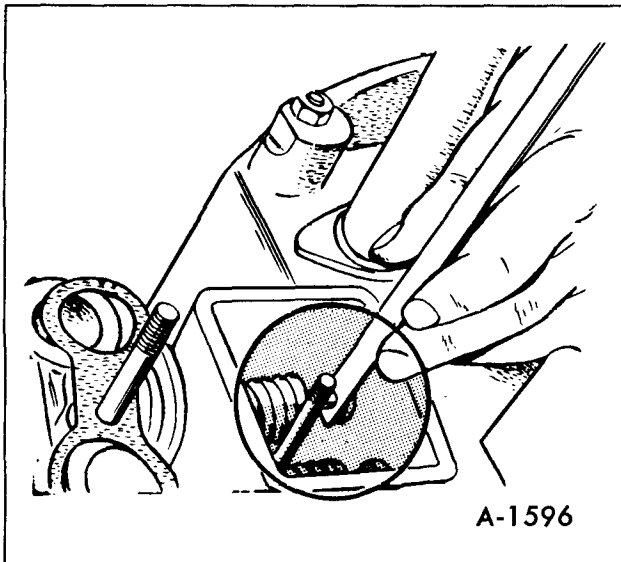

Figure 7-Adjusting Valves

8. Install all parts removed in Step 1. Tighten all screws securely. Torque manifold bolts to specified torque.

## FLYWHEEL

Removing the flywheel is a relatively simple process, but the following procedure must be followed to avoid damage to the gear case and possible personal injury.

1. Turn the flywheel mounting screw outward about two turns.

**WARNING: DO NOT REMOVE THE SCREW COMPLETELY SINCE IT ACTS AS A RESTRAINER WHEN THE FLYWHEEL SNAPS LOOSE. IF THE FLYWHEEL IS NOT HELD BY THE SCREW, THE SPRING ACTION IN THE WHEEL WILL CAUSE IT TO FLY OFF WITH GREAT FORCE WHICH CAN CAUSE PERSONAL INJURY.**

2. Install a puller bar on the flywheel as shown in Figure 8.

3. Turn the puller bar bolts in, alternately, until the wheel snaps loose on the shaft.

**CAUTION: Do not use a screwdriver or similar tool or pry behind the flywheel against the gear case. The gear case cover is die-cast material and will break if undue pressure is applied in this manner.**

4. Unscrew the puller from the flywheel, remove the flywheel mounting screw and washer and pull the flywheel off the shaft. Take care not to drop the wheel. A bent or broken fin will destroy the balance. Always use a steel key for mounting the flywheel.

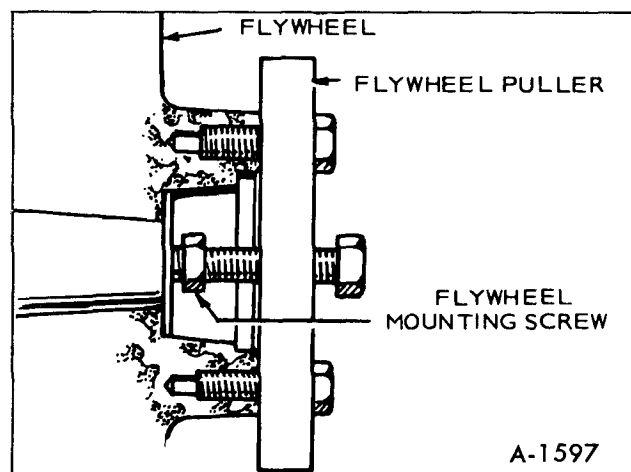

Figure 8-Flywheel Removal

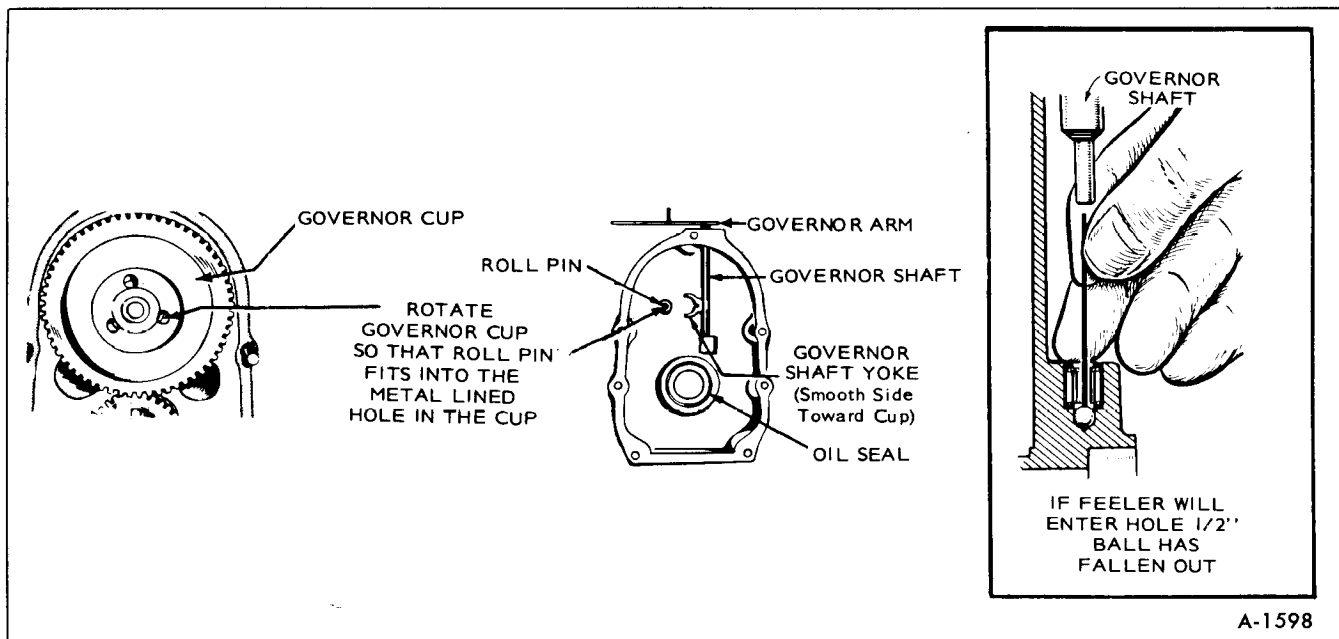

Figure 9-Gear Cover Assembly

## FLYWHEEL ALTERNATOR STATOR

After disconnecting stator terminal wires, remove the three screws securing stator to gear cover and pull off.

### GEAR COVER (FIGURE 9)

After removing the mounting screws, tap the gear cover gently with a soft faced hammer to loosen it.

When installing the gear cover, make sure that the pin in the gear cover engages the metal lined (smooth) hole in the governor cup. Turn the governor cup so that the metal lined hole is at the three o'clock position. The smooth side of the governor yoke must ride against the governor cup. Turn the governor arm and shaft clockwise as far as possible and hold in this position until the gear cover is installed flush against the crankcase. Be careful not to damage the gear cover oil seal. Adjust the roll (stop) pin to protrude to a point 3/4" from the cover's mounting surface.

### GOVERNOR CUP

With the gear cover removed, the governor cup can be taken off after removing the snap ring from

the camshaft center pin. Catch the flyballs while sliding the cup off.

Replace with a new part, any flyball which is grooved or has a flat spot; the ball spacer if its arms are worn or otherwise damaged; and the governor cup if the race surface is grooved or rough. The governor cup must be a free spinning fit on the camshaft center pin, but without any excessive play.

When installing the governor cup, tilt the engine so the gear is up, then put the flyballs in place. Install the cup and snap ring on the center pin.

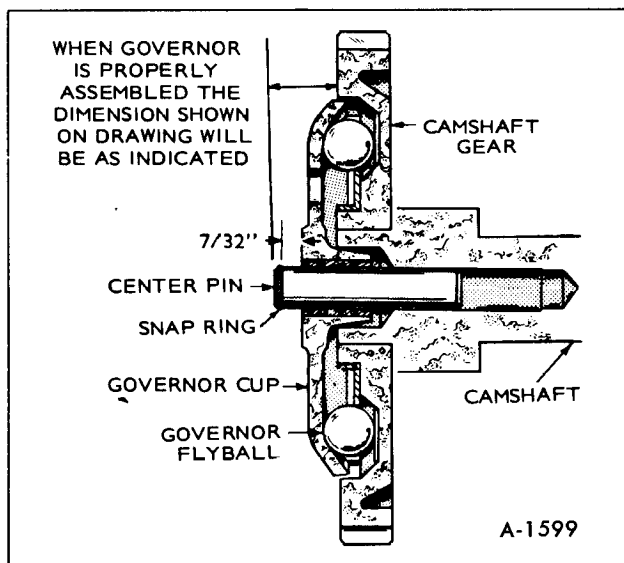

Figure 10-Governor Cup (Cross-Section)

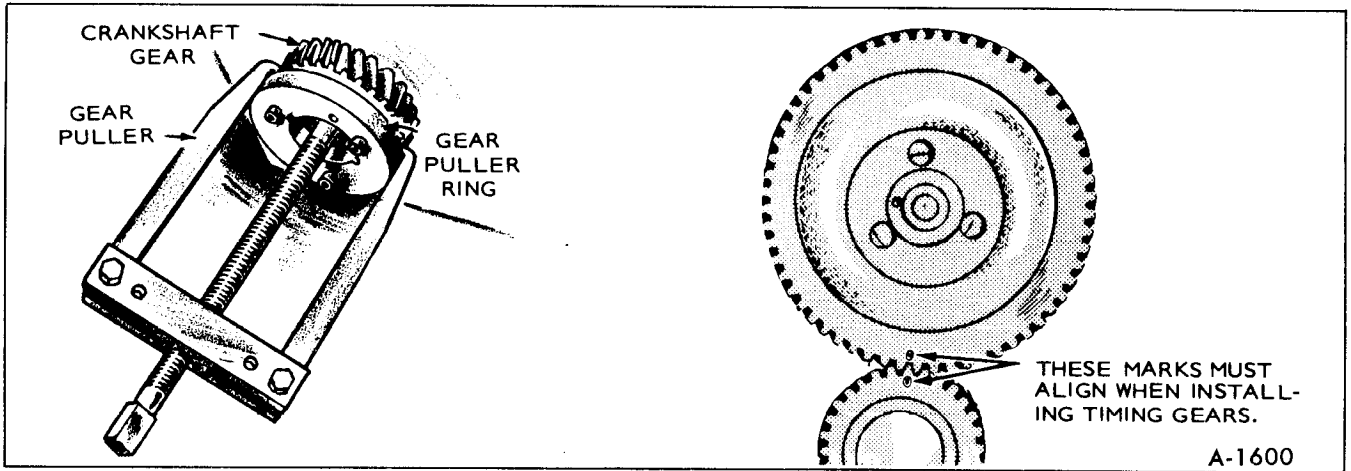

Figure 11-Timing Gear Removal and Installation

The camshaft center pin extends out 3/4" from the end of the camshaft. This distance provides an in and out travel distance of 7/32" for the governor cup, as illustrated in Figure 10. Hold the cup against the flyballs when measuring. If the distance is less (the engine will race especially at no load), replace camshaft. The camshaft center pin cannot be pulled outward or removed without damage. If the center pin extends out too far, the cup will not hold the flyballs properly.

## TIMING GEARS

If replacement of either the crankshaft gear or the camshaft gear becomes necessary, always install both gears new.

To remove the crankshaft gear, first remove the snap ring and retainer washer, then attach the gear pulling ring using two No. 10-32 screws (figure 11). Tighten the screws alternately until both are tight. Attach a gear puller to the puller ring and proceed to remove the gear.

The camshaft and gear must be replaced as an assembly. Before removing the camshaft and gear assembly, remove the cylinder head and valve assemblies. Then remove the operating plunger for the breaker points and tappets.

Each timing gear is stamped with 0 near the edge. The gear teeth must mesh so that these marks exactly coincide when the gears are installed in the engine. When installing the camshaft gear and shaft assembly, be sure that the thrust washer is properly in place behind the camshaft gear. Then install the crankshaft retaining washer and lock ring.

## PISTONS AND CONNECTING RODS

### REMOVAL

Observe the following procedure when removing pistons and connecting rods from the engine.

1. Drain oil.
2. Remove the cylinder heads and oil base pan from the engine.
3. Remove the ridge from the top of each cylinder with a ridge reamer before attempting piston removal (figure 12). Forcing the piston from the cylinder before reaming may cause damage to the piston lands.

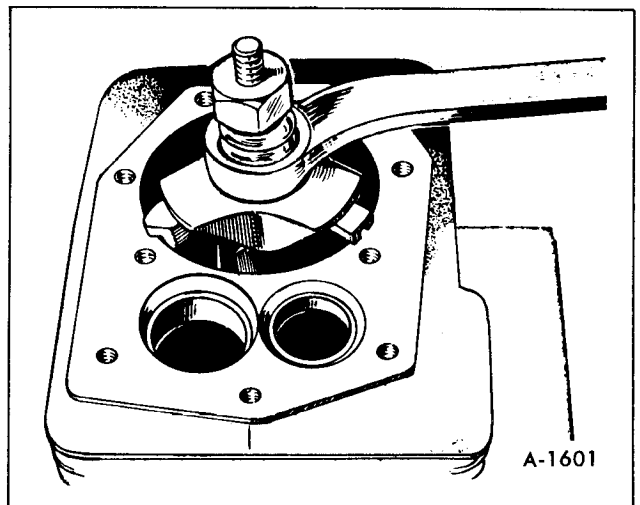

Figure 12-Removing Ridge From The Cylinder

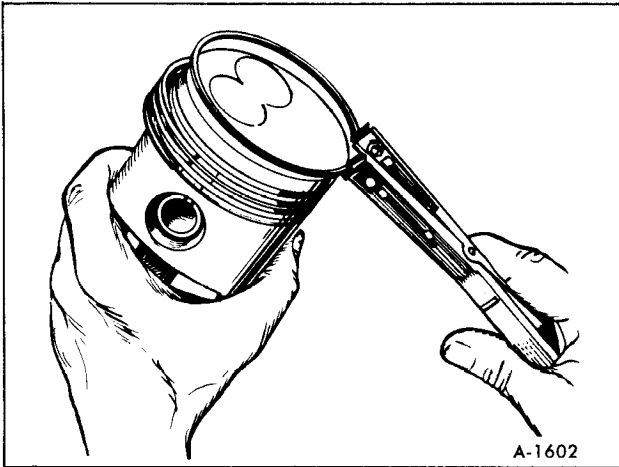

Figure 13-Removing Piston Rings

4. Turn the crankshaft until the piston is at the bottom of its stroke and remove the connecting rod bolts. Lift the rod bearing cap from the rod and push the rod and piston assembly out through the top of the cylinder using a hammer handle. Avoid scratching the crankpin and cylinder wall when removing the piston and rod.

**NOTE:** Mark each piston and rod assembly so they can be returned to their respective cylinders after overhaul. Keep connecting rod bearing caps with their respective rods.

5. Remove the piston rings from the piston with a piston ring spreader as shown in Figure 13. Remove the piston retainer and push the piston pin out.

## CLEANING

Remove dirt and deposits from the piston sur-

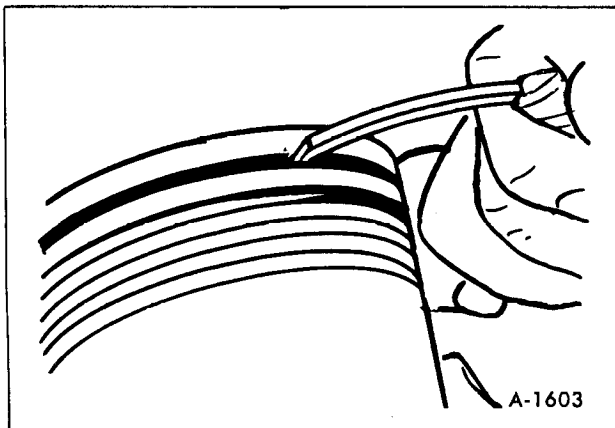

Figure 14-Piston Groove Cleaning

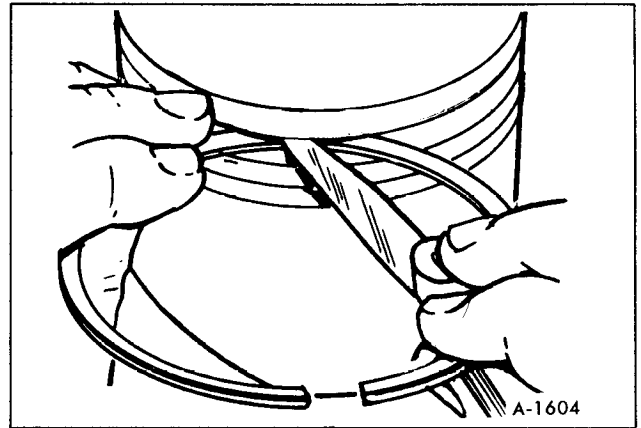

Figure 15-Checking Ring Side Clearance

faces with an approved cleaning solvent. Clean the piston ring grooves with a groove cleaner or the end of a piston ring filed to a sharp point (figure 14). Care must be taken not to remove metal from the groove sides.

**NOTE:** Do not use a caustic cleaning solvent or wire brush for cleaning pistons.

When cleaning the connecting rods in solvent, include the rod bore. Blow out all passages with compressed air.

## INSPECTION

The following text contains inspection procedures concerning pistons and connecting rods.

### 1. Piston Inspection:

a. Inspect the pistons for fractures at the ring lands, skirts and pin bosses. Check for wear at the ring lands using a new ring and feeler gauge as shown in Figure 15. Replace the piston when the side clearance of the top compression ring reaches 0.008".

b. Replace pistons showing signs of scuffing, scoring, worn ring lands, fractures or damage from preignition. Excessive piston wear near the edge of the top ring land indicates preignition.

### 2. Connecting Rod Inspection

a. Replace connecting rod bolts or nuts with damaged threads. Replace connecting rods with deep nicks, signs of fractures, scored bores or bores out of round more than 0.002".

b. Use a new piston pin to check connecting rod for wear. A push fit clearance is required and

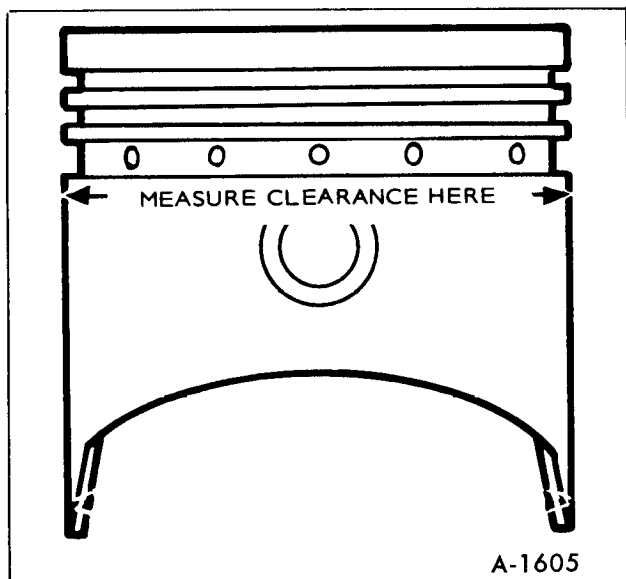

Figure 16—Measuring Diameter of Piston

varies from engine to engine. If a new piston pin falls through a dry rod pin bore as a result of its own weight, replace the rod.

## REPAIR

### 1. Fitting Pistons:

a. Proper piston tolerances must be maintained for satisfactory operation.

b. Measure the piston as shown in Figure 16 to be sure the total piston-to-cylinder clearance follows specifications.

### 2. Fitting Piston Rings:

a. Install the piston ring in the cylinder bore. Invert the piston and push the ring to the end of ring travel, about halfway into the bore, which trues the ring end gap. Check the gap with a feeler gauge as shown in Figure 17.

b. The practice of filing ring ends to increase the end gap is not recommended. If the ring end gap does not meet specifications, check for the correct set of rings and correct bore size. A cylinder bore that is 0.001" undersize will reduce the end gap 0.003".

## CYLINDER BLOCK

### INSPECTION:

1. Make a thorough check for cracks. Small

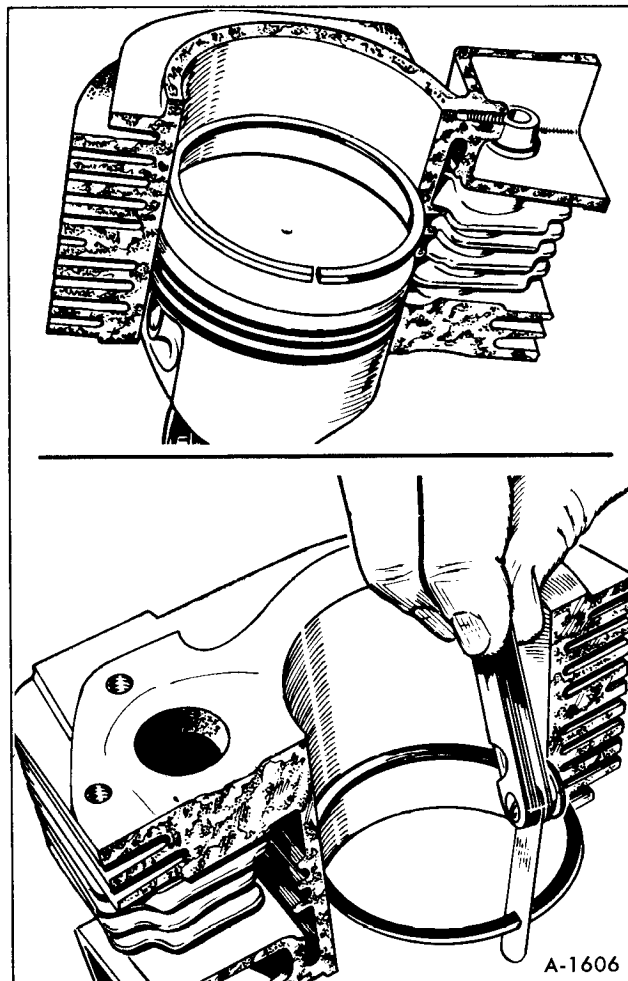

Figure 17—Checking Ring End Gap

cracks may be detected by coating the suspected area with a mixture of 25% kerosene and 75% light motor oil. Wipe the part dry and immediately apply a coating of zinc oxide (white lead) dissolved in wood alcohol. If cracks are present, the white coating will become discolored at the defective area.

2. Inspect the cylinder bore for scoring. Check the Welsh plugs for a tight, even fit and fins for breakage.

3. Check the cylinder bore for taper, out of round and wear, with a cylinder bore gauge, telescope gauge or inside micrometer (figure 18). These measurements should be taken at four places – the top and bottom of piston ring travel.

4. Record measurements taken lengthwise at the top and bottom of the piston travel as follows:

a. Lengthwise of the block, measure and record as "A" the diameter of the cylinder at the top of the cylinder where greatest ring wear occurs.

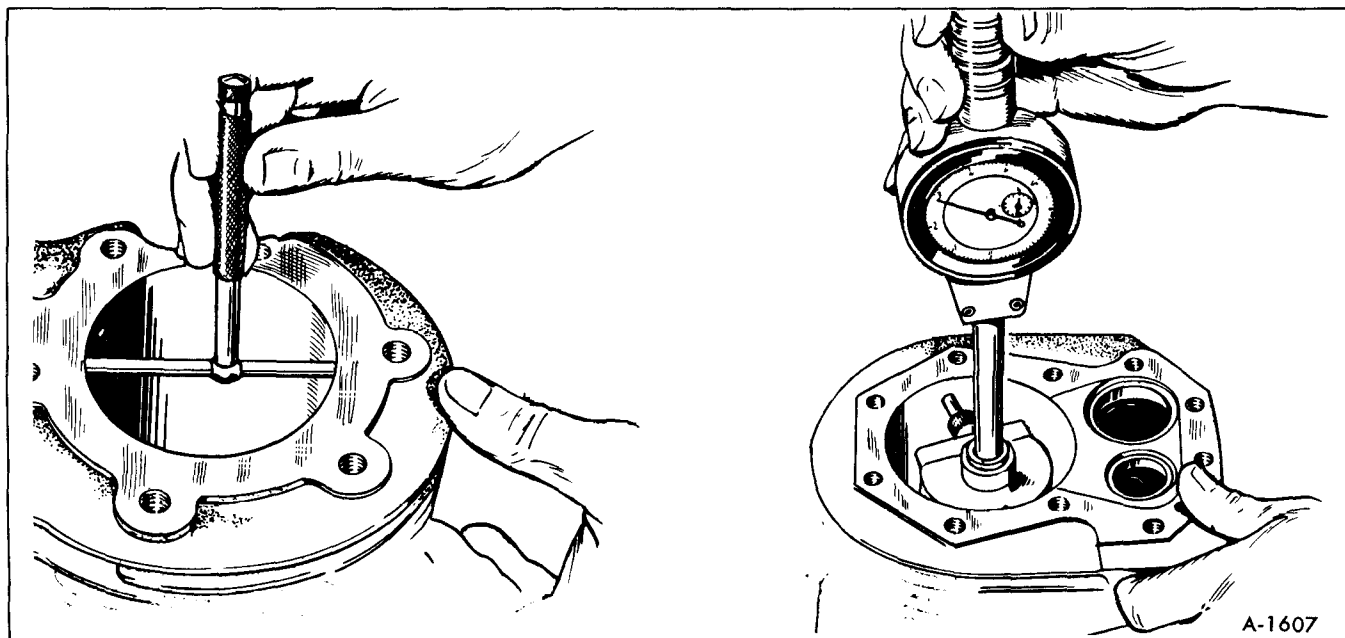

Figure 18—Methods of Measuring The Diameter of a Cylinder

b. Also, lengthwise of the block, measure and record as "B" the cylinder diameter at the piston skirt travel.

c. Crosswise of the block, measure and record as "C" the diameter of the top of the cylinder at the greatest point of wear.

d. Measure and record as "D" the diameter at the bottom of the cylinder bore and crosswise of the block.

e. Reading "A" compared to reading "B" and reading "C" compared to reading "D" indicates cylinder taper.

f. If cylinder taper exceeds 0.005", rebore and hone to accommodate the next oversize piston. Reading "A" compared to reading "C" and reading "B" compared to reading "D" indicates whether or not the cylinder is out of round. If the out of round exceeds 0.002", the cylinders must be rebored and honed for the next oversize piston. A reboring machine is used when going to oversize pistons. The following repair data covers honing to oversize by use of a hone.

duty drill which operates at approximately 250 to 450 rpm.

3. Connect drill to hone and start drill. Move the hone up and down in the cylinder approximately 40 cycles per minute. Usually the bottom of the cylinder must be worked out first because it is smaller. Then when the cylinder takes a uniform diameter, move the hone up and down all the way through the bore. Follow the hone manufacturer's recommendations for wet or dry honing and oiling the hone.

4. Check the diameter of the cylinder regularly during honing. A dial bore gauge is the easiest

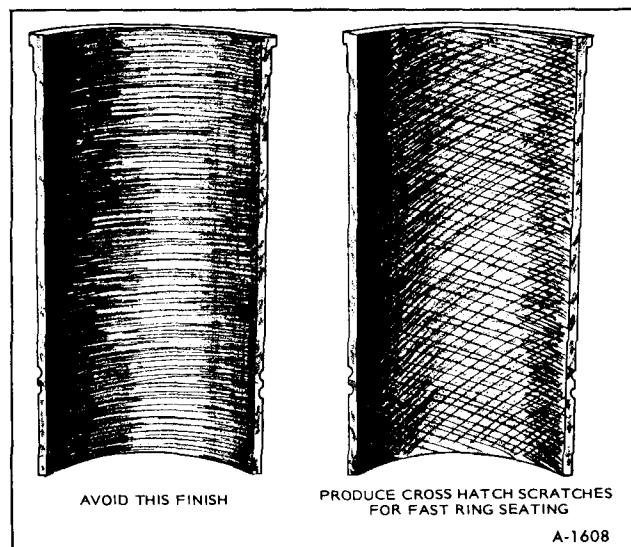

Figure 19—Crosshatching Cylinder Block

**REPAIR:**

1. A hone can be used to refinish a cylinder.

2. Anchor the block solidly for either vertical or horizontal honing. Use either a drill press or heavy-

method but a telescoping gauge can be used. Check the size at six places in the bore: measure twice at the top, middle and bottom at 90° angles.

5. The cross hatch formed by the scratching of the stones should form an angle of 23° as shown in Figure 19. This can be achieved by moving the hone up and down in the cylinder about 40 cycles per minute.

6. Clean the cylinder block thoroughly with soap, water and clean rags. A clean white rag should not be soiled on the wall after cleaning is complete. Do not use a solvent or gasoline since they wash the oil from the walls but leave the metal particles.

7. Dry the crankcase and coat it with oil.

## CRANKSHAFT

Inspect the bearing journals. If they are scored and cannot be smoothed out by dressing down, replace the crankshaft.

Whenever making major repairs on the engine, always inspect the drilled passages of the crankshaft. Clean them to remove any foreign material and to assure proper lubrication of the connecting rods.

## BEARINGS

### Removal

Removing camshaft or crankshaft bearings requires complete disassembly of the engine. Use a press or a suitable drive plug to remove the bearings. Support the casting to avoid distortion and avoid damaging the bearing bore during removal and installation. Use oil on the bearings to reduce friction when installing and again lubricate with oil after installing.

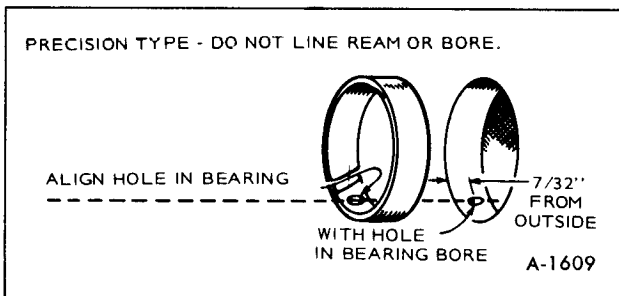

Figure 20-Crankshaft Bearing

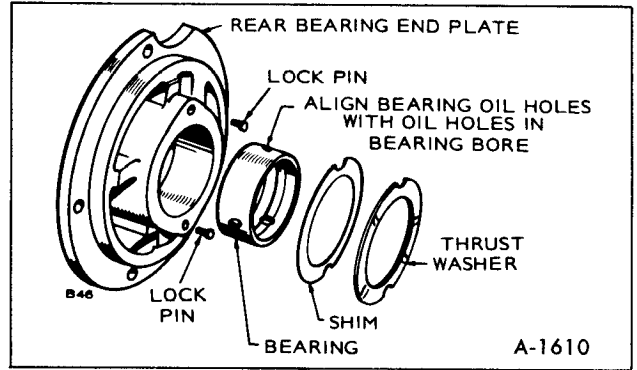

Figure 21-Bearing For Rear Bearing Plate

### Installation

Crankshaft main bearings are precision type which do not require line reaming or line boring after installation. They are available in standard size and .002" undersize. Expand the bearing bore by placing the casting in hot water or in an oven heated to 200°F. *If a torch is used, apply only a slight amount of heat.*

To ease assembly, cool the precision bearing to shrink it. Align the oil hole(s) in the bearing with the oil hole(s) in the bearing bore Figure 20. The oil passage must be at least 1/2 open. lubricate bearings with SAE20 oil before installing. The cold oiled precision bearing should require only light taps to position it with a driving tool. If head of lock pin is damaged, use side cutters or Easy Out tool to remove and install new pin. Apply oil to thrust washer (one used with each bearing) to hold it in place while

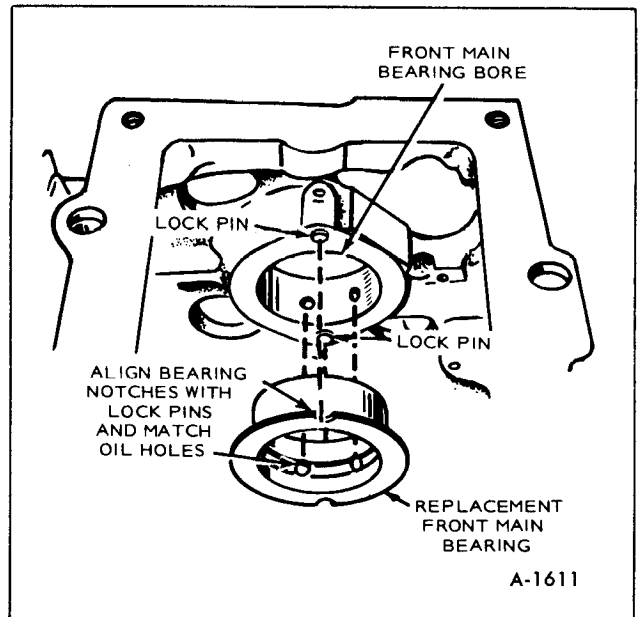

Figure 22-Front Bearing Installation



installing the crankshaft. Oil grooves in thrust washers must face the crankshaft and washers must be flat (not bent). The two notches on each washer must fit over the two lock pins to prevent riding on the crankshaft.

**NOTE:** Original front bearing uses a separate thrust washer. Replacement front bearing is a one piece assembly with thrust washer part of the bearing. Do not use a separate thrust washer when installing this replacement part. See Figures 21 and 22.

New camshaft bearings are precision type which *do not* require line reaming or line boring after installation. Coat the bearing with SAE20 to reduce friction. Place the bearing on the crankcase over the bearing bore with the elongated hole in proper position and narrow section facing out (except bores without oil holes install with bearing groove at the top). Be sure to start the bearing straight. Press the front bearing in flush with the outside end of the bearing bore. Press the rear bearing in flush with the bottom of counterbore which received the expansion plug.

## CRANKSHAFT ENDPLAY

After the rear bearing end plate has been tightened using the torque recommended in Torque Specifications check the crankshaft endplay as shown in Figure 23. If there is too much endplay (see Specifications), remove the rear bearing end plate and add a shim between the thrust washer and plate. Reinstall the end plate making sure the thrust washer and shim notches line up with the lock pins. Torque and recheck endplay of the crankshaft.

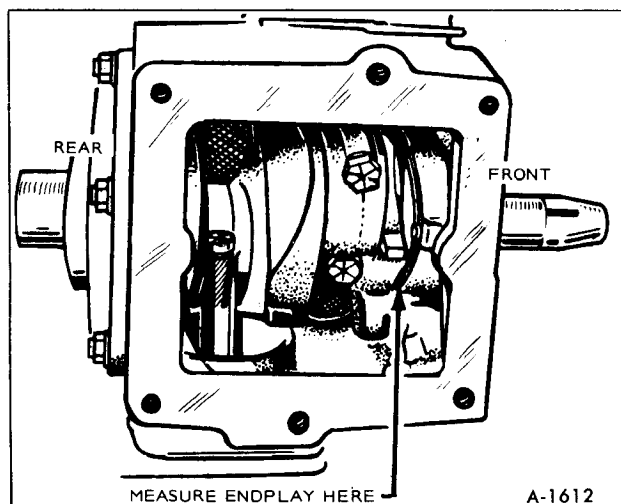

Figure 23—Crankshaft Endplay

## CHECKING BEARING CLEARANCE WITH PLASTIGAUGE

1. Make certain that all parts are marked or identified so that they are reinstalled in their original positions.

2. Place a piece of correct size Plastigauge in the bearing cap the full width of the crankshaft rod surface about 1/4 inch off center (figure 24).

3. Rotate the crank about 30° from bottom dead center and reinstall the bearing cap; Tighten the bolts to the torque specified at the end of this section. Do not turn the crankshaft.

4. Remove the bearing cap. Leave the flattened Plastigauge on the part to which it has adhered and compare the widest point with the graduations on the Plastigauge envelope to determine bearing Clearance.

## OIL SEALS (FIGURE 25)

The bearing plate must be removed to replace the oil seal. Drive the oil seal out from the inside.

Before installing the seals, fill the space between lips with a multi-purpose grease. This will improve sealing.

When installing the gear cover oil seal, tap the seal inward until it is 31/32" from the mounting face of the cover.

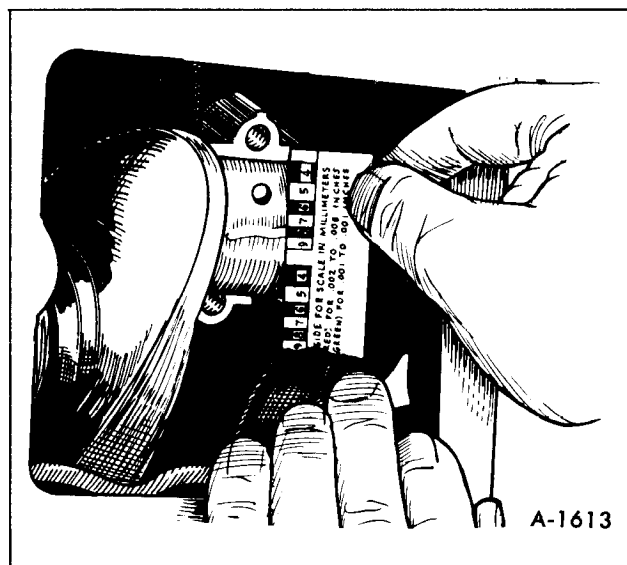

Figure 24—Measuring Bearing Clearance

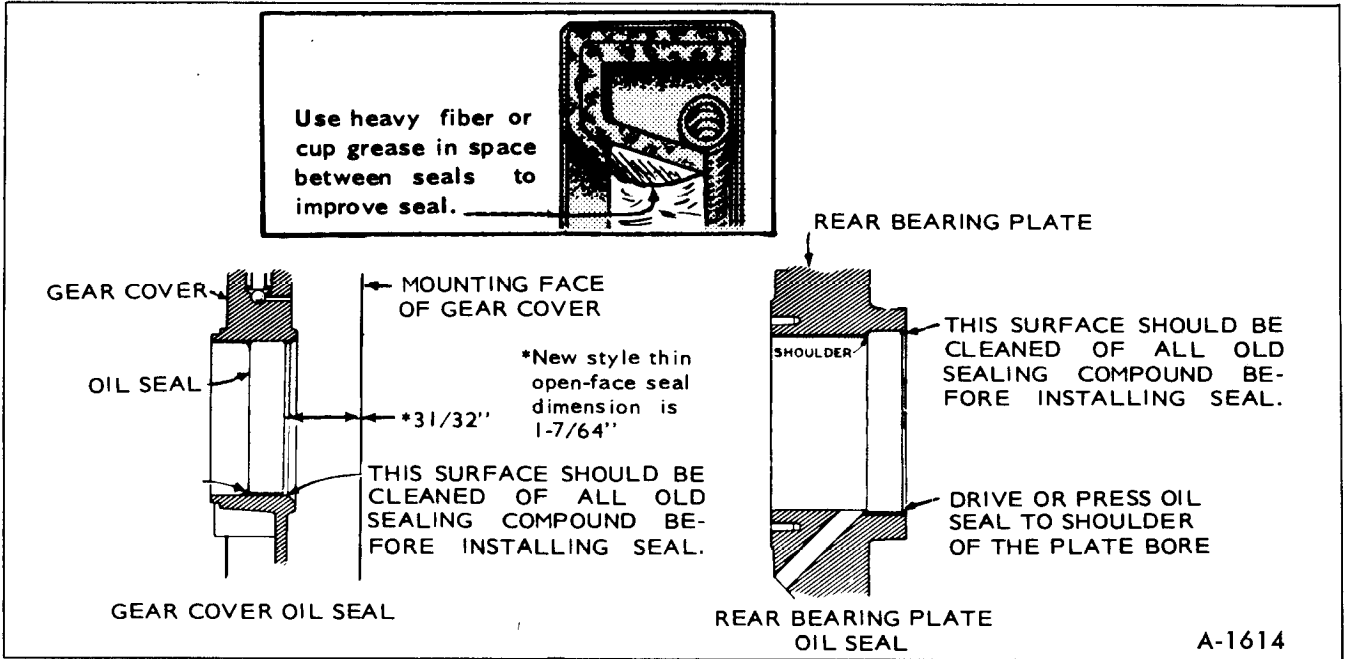

Figure 25-Gear Cover and Rear Bearing Plate Oil Seals

When installing the bearing plate oil seal, tap the seal into the bearing plate bore to bottom against the shoulder in the plate bore. Use a seal expander or place a piece of shim stock around the end of the crankshaft, when replacing the bearing plate to avoid damaging the seal. Remove the shim stock as soon as the plate is in place.

2. Position piston on its respective rod and install the pin.

3. Install the rings on the pistons starting with the oil control ring (figure 26). Use a piston ring spreader to prevent twisting or excessive expansion of the ring. Some oil control rings and all compression rings have a dot or the word "top" on one side of the

**PISTON ASSEMBLY**

1. Lubricate all parts with engine oil.

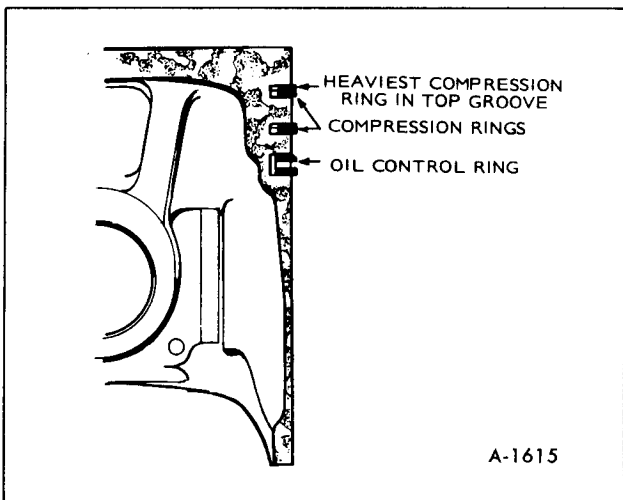

Figure 26-Piston Rings

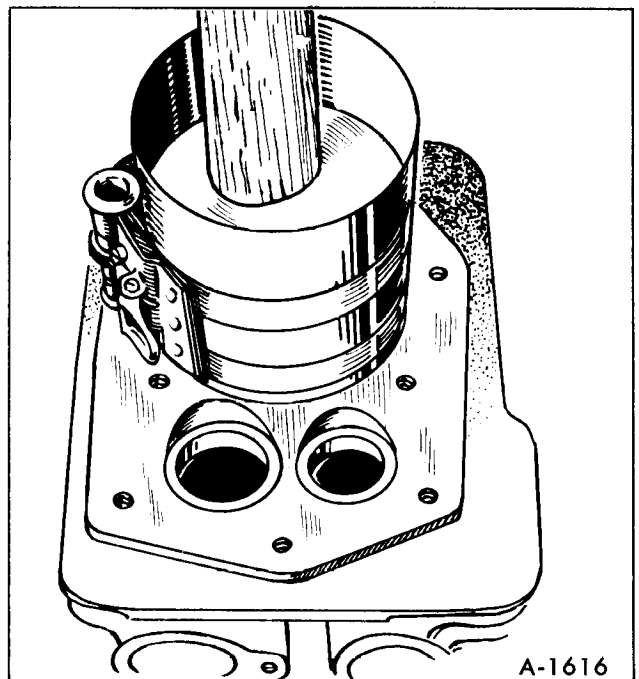

Figure 27-Installing Piston

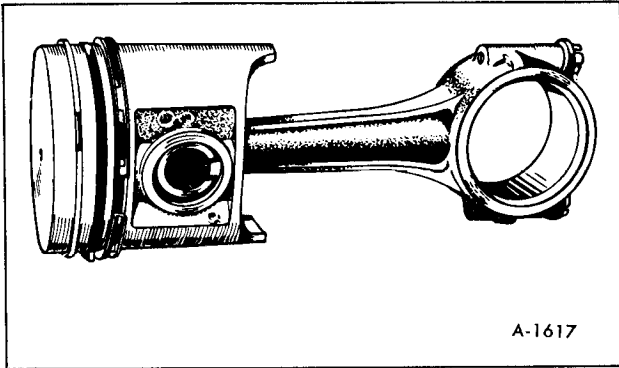

Figure 28—Piston Assembly

ring to indicate which side faces the top of the piston. Unmarked piston rings can be installed either way. If the oil control ring has a coil expander, install the expander first and then close until the coil ends butt. The joint should be 180° from the gap of that ring.

### INSTALLATION OF PISTON IN CYLINDER:

1. Turn the crankshaft to position the number one rod bearing journal at the bottom of its stroke.

2. Lubricate the number one piston assembly and inside of the cylinder. Compress the rings with a ring compressor as shown in Figure 27.

3. Position the piston and rod assembly in the cylinder block.

**NOTE:** The connecting rod numbers should always face away from the camshaft or bottom side of engine. See Figure 28.

4. Tap the piston down into the bore with the handle end of a hammer until the connecting rod is seated on the journal (figure 27). Install the bearing cap on the rod with the witness marks and stamped reference numbers matching the marks on the rod. Install and tighten the bolts to the specified torques.

The bearing cap must be tapped several times to properly align it with the rest of the connecting rod. Clearance varies on the journal if this is not done.

Install the remaining pistons and rods in the same manner. Crank the engine over by hand to see that all bearings are free.

5. Install the oil base with a new gasket.

Torque oil base thru-bolts to 18-23 ft.-lb.

Torque oil pan bolts to 8-12 ft.-lb.

6. Install the cylinder heads and torque 14-16 ft. lb. (17-19 ft. lb. on 6KW).

7. Réplace oil and break-in engine.

### CYLINDER HEADS

Remove the cylinder heads for cleaning when poor engine performance is noticed.

1. Use a 1/2 inch socket wrench to remove cylinder head nuts. Lift heads off.

**CAUTION:** Do not remove heads when they are hot. Warpige may occur.

2. After removing heads, clean out all carbon deposits. Be careful not to damage the outer sealing edges where gaskets fit. The heads are made of aluminum and can be damaged by careless handling.

3. Use new head gaskets and clean both the heads and the cylinder block thoroughly where the head gaskets rest.

4. Place heads in position and follow head torque

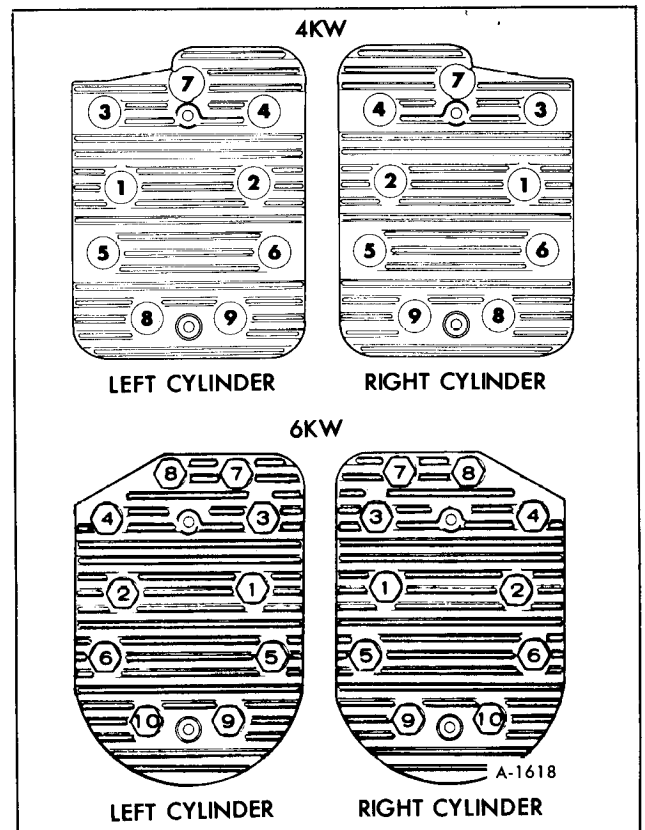

Figure 29—Cylinder Head Tightening Sequence

tightening sequence shown in Figure 29. Start out tightening all Nuts to 5 ft.-lb, then 10 ft.-lb, etc., until all Nuts are torqued 14-16 ft - lb. (17-19 ft.-lb. on 6KW).

5. Recheck torque before engine has run a total of 50 hours.

## OIL SYSTEM

### CRANKCASE OIL

Change crankcase oil every 100 operating hours and only when engine is warm.

(EXCEPTION: Drain initial oil fill at 25 operating hours.)

To drain, remove the 1/2 inch cap screw (requiring 3/4" socket) on oil pan. After oil drains, replace the cap screw and refill crankcase with a good quality detergent oil. Refer to Section 24A for specific details on oil for the Onan Motor Generator.

### OIL FILTER

Change the crankcase oil filter every 200 hours. Filter is located above starter on right side of engine. Remove by turning filter counterclockwise with a filter wrench. Before installing new filter, coat gasket on base of filter with a light film of oil. Install by turning clockwise until friction is noted, then turn an additional 1/4 to 1/2 turn. See Figure 30.

**CAUTION:** Do not over-torque oil filter. Be sure ring is installed around oil filter. This ring acts as an air seal and prevents loss of cooling air.

### CRANKCASE BREATHER

This engine uses a crankcase breather valve for maintaining crankcase vacuum. No maintenance is generally required. If the crankcase becomes pressurized as evidenced by oil leaks at the seals, clean

baffle and valve in a suitable solvent. Crankcase breather disassembly requires removal of exhaust manifold. See Figure 31.

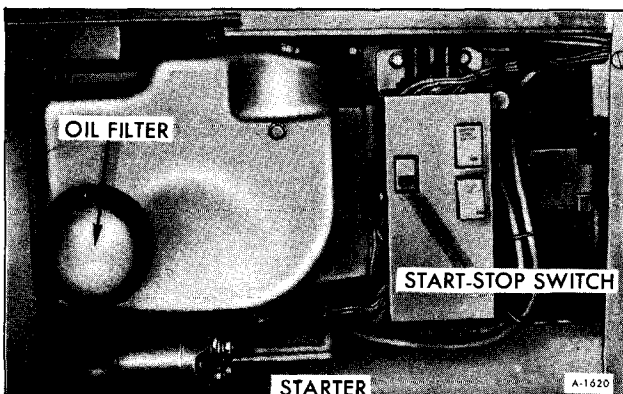

Figure 30—Oil Filter Location

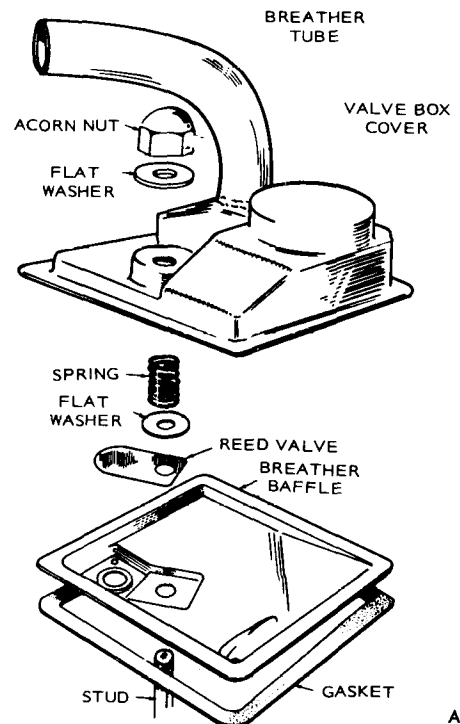
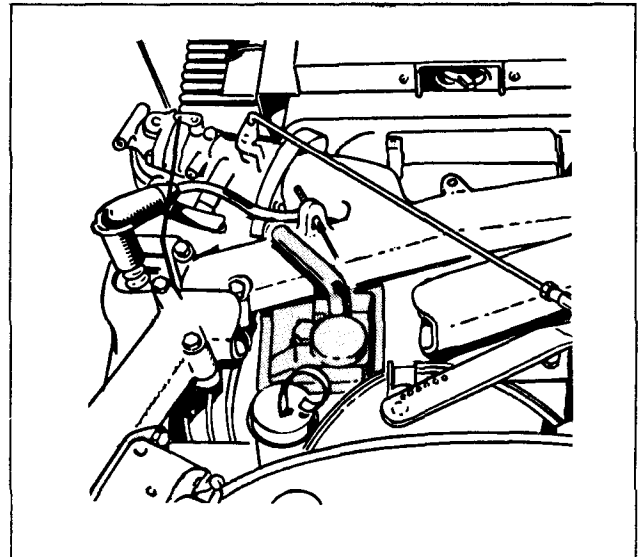

Figure 31—Crankcase Breather

# FUEL SYSTEM

## CARBURETOR REPAIR (FIGURE 32)

### REMOVAL

1. Disconnect fuel inlet hose and crankcase breather hose.
2. Remove air cleaner assembly.
3. Disconnect governor, throttle linkage, and choke control.
4. Remove two-hold down screws and lift carburetor from intake manifold.

## REPLACING NEEDLE AND VALVE SEAT (FIGURE 33)

1. Remove 7/16" retainer at base of fuel bowl and lift bowl from carburetor.
2. Push out pin that holds float to carburetor body. Disconnect spring holding needle to float.
3. Remove float and set aside in a clean place. Pull out needle and using a large screwdriver remove needle valve seat.
4. Install new valve seat and needle and replace float.
5. Adjust float.

## CARBURETOR CLEANING AND INSPECTION

To clean the carburetor, soak all components thoroughly in a good carburetor cleaner, following the manufacturer's instructions. Be sure to remove all carbon from carburetor bore, especially in the area of the throttle valve. After soaking, clean out all passages with filtered, compressed air.

Check the adjusting needles and nozzle for damage. If float is loaded with fuel or damaged, replace it. The float should fit freely on its pin without binding.

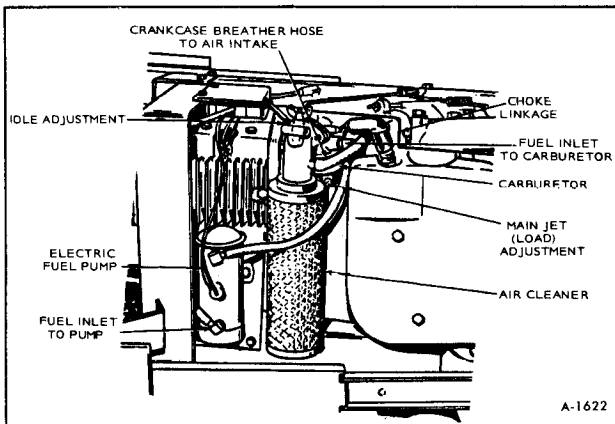

Figure 32-Fuel System (Typical)

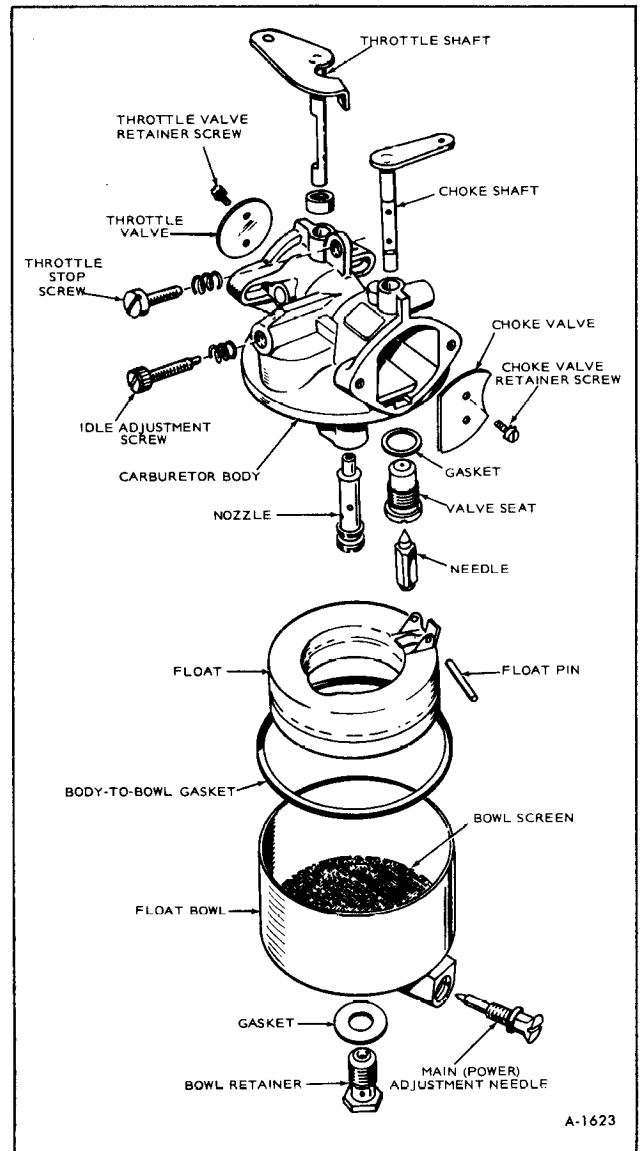

Figure 33-Carburetor Components

Check the choke and throttle shafts for excessive side play and replace if necessary.

### CARBURETOR FLOAT ADJUSTMENT

1. Invert float and casting.

2. With the float resting lightly against the needle and seat, there should be 3/32-inch clearance between base of float and carburetor casting.

**NOTE:** A drill bit can be used for this measurement as shown in Figure 34. Use a 3/32-inch drill bit.

3. If it is necessary to reset float level, remove the float from carburetor and bend the float tang, near the pin, to obtain correct float level.

**CAUTION:** Do not bend the float when installed; doing so may cause deformation of needle or seat.

4. Check the float closely for signs of leakage. Replace float if damaged or filled with gasoline.

5. Before assembling carburetor, remove filter screen from float bowl and clean both screen and base of float bowl.

6. Install new gaskets when reassembling.

### FUEL PUMP FILTER ELEMENT (FIGURE 35)

Every 400 hours or sooner on the 4KW, and

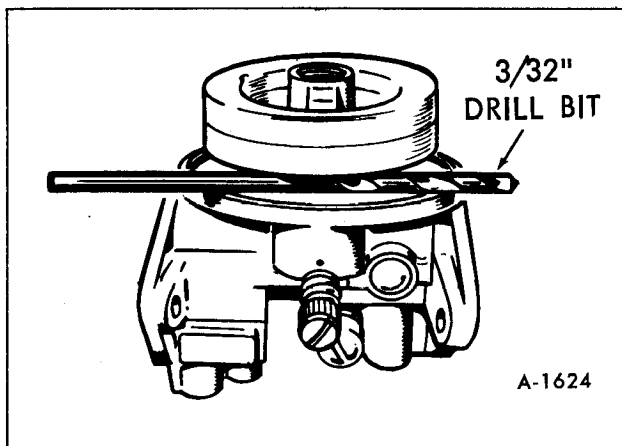

Figure 34—Carburetor Float Adjustment

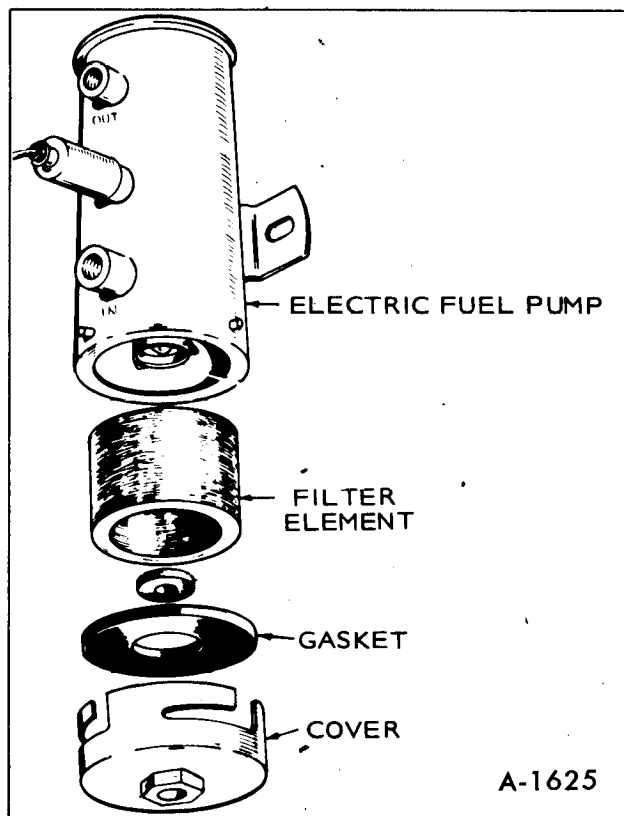

Figure 35—Fuel Pump Filter Element

every 500 hours on the 6KW, drain fuel pump and check filter element. Remove fuel pump mounting screws and turn off hex nut on base of pump. If element appears dirty, replace with a new one. Be sure to replace gaskets when reassembling.

### AIR CLEANER ELEMENT (FIGURE 36)

Check and clean element at least every 100 hours. Loosen wing nut to remove. Clean by tapping base lightly on a flat surface. Replace element at least every 200 operating hours on the 4KW and every 500 hours on the 6KW; clean or replace more often in dusty conditions.

### CARBURETOR ADJUSTMENTS (FIGURE 37)

The carburetor has a main fuel (power) adjustment and an idle fuel adjustment. The main adjustment affects operation under heavy load conditions. The idle adjustment affects operation under light or no-load conditions. Under normal circumstances, adjustments should not be disturbed. If adjustments

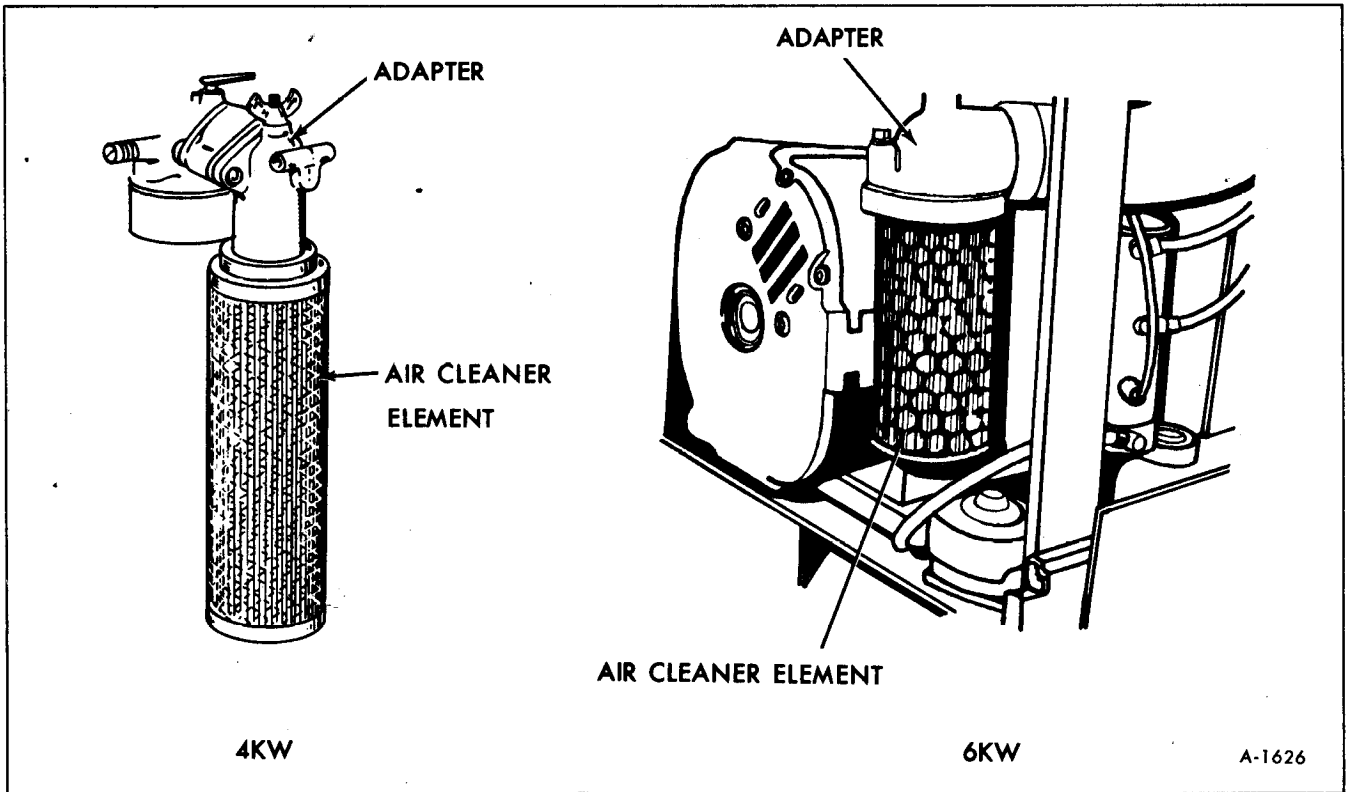

Figure 36—Air Cleaner Element

have been disturbed turn main fuel jet 1-1/4 turn off its seat and idle fuel jet one turn off its seat to permit starting. Then readjust them for smooth operation.

**CAUTION:** Forcing the needle against its seat will damage it. The needle does not completely shut off fuel when turned fully in.

Set the throttle stop screw (located on the carburetor throttle lever), with no load connected to the plant. Turn stop so it just touches adjustment screw; then turn adjustment screw (with stop still touching it) until unit is running at 1500 rpm. When stop is released, governor will then control no-load speed at 1850 to 1890 rpm.

Before final adjustment, allow the engine to warm up. Adjust the idle fuel jet with no load connected. Open the main jet until the engine runs smooth under acceleration with no load. Slightly more fuel may be needed (open about 1/4 turn further) when sudden load is applied or if operating in extremely cold weather.

If the engine develops a “hunting” condition (alternate increase and decrease of engine speed), try correcting by opening the main adjusting needle a little more.

**CAUTION:** Do not open main fuel jet more than 1/2 turn beyond the maximum power point.

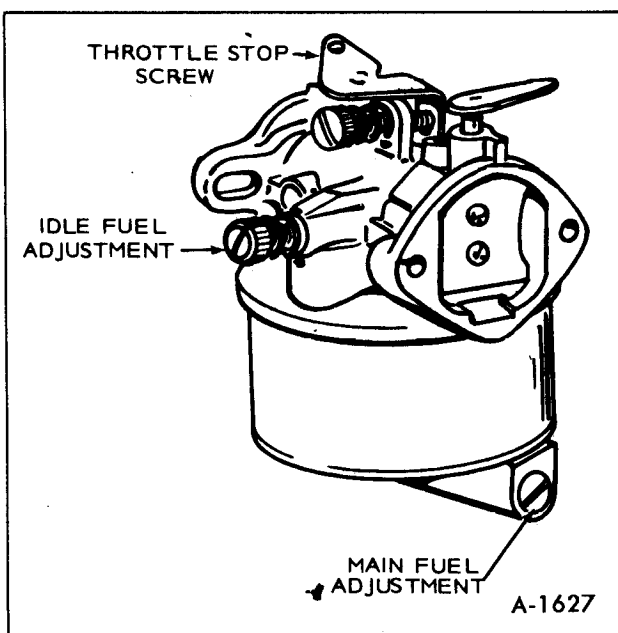

Figure 37—Carburetor Adjustment Screws

## GOVERNOR

Before making governor adjustments, run the unit about 15 minutes under light load to reach normal operating temperature. (If governor is completely out of adjustment, make a preliminary adjustment at no load to first attain a safe voltage operating range).

Engine speed determines the output voltage and current frequency of the generator. By increasing the engine speed, generator voltage and frequency are increased, and by decreasing the engine speed, generator voltage and frequency are decreased. An accurate voltmeter or frequency meter (preferably both) should be connected to the generator output in order to correctly adjust the governor. A small speed drop not noticeable without instruments will result in an objectionable voltage drop. The engine speed can be checked with a tachometer.

A binding in the bearings of the governor shaft, in the ball joint, or in the carburetor throttle assembly will cause erratic governor action or alternate increase and decrease in speed (hunting). A lean carburetor adjustment may also cause hunting. Springs of all kinds have a tendency to lose their calibrated tension through fatigue after long usage. If all governor and carburetor adjustments are properly made, and the governor action is still erratic, replacing the spring with a new one and resetting the adjustments will usually correct the trouble.

1. Adjust the carburetor idle needle with no load connected.

2. Adjust the carburetor main jet for the best fuel mixture while operating the set with a full rated load connected.

3. Adjust the length of the governor linkage and check linkage and throttle shaft for binding or excessive looseness.

4. Adjust the governor spring tension for rated speed at no load operation.

5. Adjust the governor sensitivity.

6. Recheck the speed adjustment.

7. Set the carburetor throttle stop screw.

## LINKAGE

The engine starts at wide open throttle. The length of the linkage connecting the governor arm to the throttle shaft and lever is adjusted by rotating the ball joint. Adjust this length so that with the engine stopped and tension on the governor spring, the stop on the carburetor throttle lever just contacts the stop. This setting allows immediate control by the governor after starting. It also synchronizes travel of the governor arm and the throttle shaft.

## SPEED ADJUSTMENT

With the warmed-up unit operating at no load,

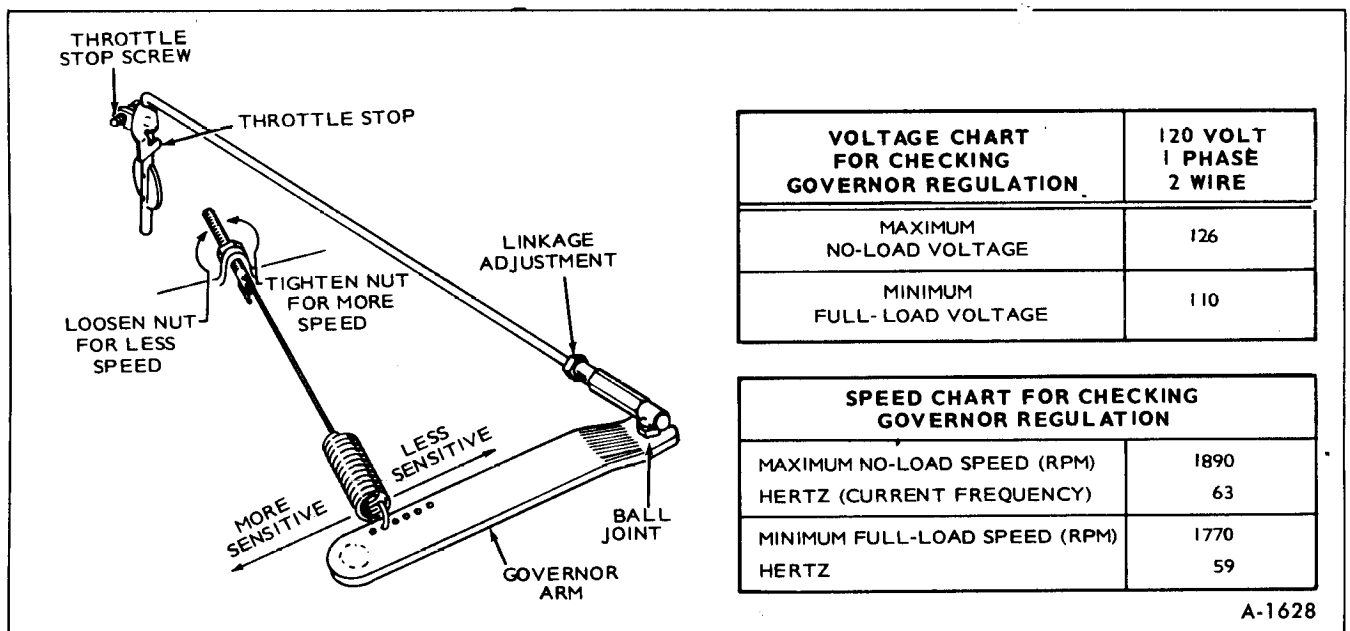

A-1628

Figure 38-Governor Adjustments



adjust the tension of the governor spring (See figure 38). Turn the speed adjusting nut to obtain a voltage and speed reading within the limits shown.

### SENSITIVITY ADJUSTMENT

Referring to Figure 38 check the voltage and speed, first with no load connected and again with a full load. Adjust the sensitivity to give the closest regulation (least speed and voltage difference between no load and full load) without causing a hunting condition.

To increase sensitivity (closer regulation), shift the spring toward the governor shaft.

An adjustment for too much sensitivity will cause alternate increase and decrease of engine speed (hunting).

To decrease sensitivity, shift the spring toward the outer end of the governor arm. Too little sensitivity will result in too much difference in speed between no load and full load conditions.

Any change in the sensitivity adjustment usually requires a compensating speed (spring tension) adjustment.

## IGNITION AND BATTERY CHARGING SYSTEM

### BREAKER POINTS

To maintain maximum efficiency from the engine, change the breaker points every 200 hours of operation. Proceed as follows:

1. Remove the two screws and the cover on the breaker box.
2. Remove the two spark plugs so engine can be easily rotated by hand. Check condition of spark plugs at this time.
3. Refer to Figure 39, remove mounting nut (A) and pull the points out of the box just far enough so screw (B) can be removed and leads disconnected.
4. Remove screw (C) and replace condenser with a new one.
5. Replace points with a new set but do not completely tighten mounting nut (A).
6. Remove the dot button on blower housing. This provides an access to view timing mark.

### GOVERNOR BALL JOINT

Every 200 hours or sooner, check the governor linkage for freedom of movement through its travel. Clean and lubricate ball joint with lubricating graphite.

### ELECTRIC CHOKE

Manually check movement of choke travel to be sure it is not stuck open or closed. Voltage at choke should be 12 volts during start and drop to zero during run. If choke does not move at room temperature with 12 volts applied, replace it.

This choke should not require any seasonal readjustment. If adjustment becomes necessary proceed as follows:

1. Loosen choke lever clamp screw.
2. With lever fully forward (away from carburetor), adjust so choke valve is completely closed or not more than 1/4 inch open.
3. Tighten clamp screw.

7. ON 4KW, rotate the engine clockwise (facing flywheel) by hand until the 26° BTC mark on gear cover aligns with mark on flywheel. Turn another 1/4 turn (90°) to ensure points are fully open.

ON 6KW, rotate engine clockwise (facing flywheel) By Hand Until the 25° BTC mark aligns with hole. Turn another 1/4 turn (90°) to ensure points are fully open.

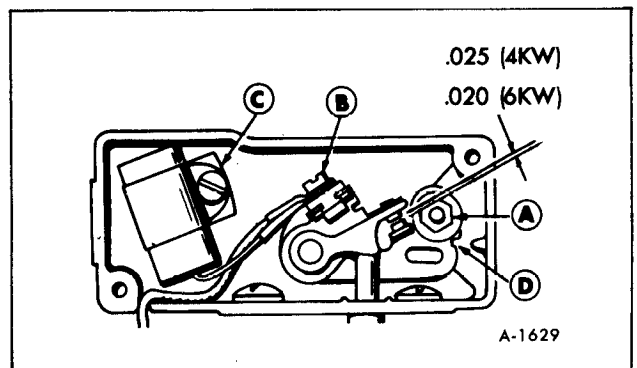

Figure 39—Breaker Point Adjustments

8. Using a screwdriver inserted in notch (D) on the right side of points, turn points until gap measures .025" (.020" on 6KW) with a flat thickness gauge. (Be sure feeler is clean.) Tighten mounting screw and recheck gap. Timing is automatically set.

## IGNITION TIMING

The timing on the engine is preset at the factory. A non-movable breaker point box is used, however a slight timing change could be made by adjusting points.

The engine is equipped with an automotive type battery ignition system. Both spark plugs fire simultaneously, thus the need for a distributor is eliminated. Spark advance is set to specifications and should be maintained for best engine performance. Always check timing after replacing ignition points or if noticing poor engine performance. Proceed as follows:

### TIMING PROCEDURE (ENGINE RUNNING - HOT SETTING) (4KW)

1. To check the ignition timing with unit running use a timing light. Connect the timing light according to its manufacturer's instructions. Either spark plug can be used as they fire simultaneously.

2. Remove the dot button on blower housing to provide an access to view timing marks (See figure 40).

3. Start the engine and check the timing. The mark on the flywheel should line up with the 21° mark on the cover.

4. Install dot button, breaker box cover and any other hardware removed from engine.

### TIMING PROCEDURE (ENGINE RUNNING - HOT SETTING) (6KW)

1. To check the ignition timing with unit running, use a timing light. Connect the timing light according to its manufacturer's instructions. Either spark plug can be used as they fire simultaneously.

2. A small hole on the rear portion of blower housing provides an access to view timing marks (See figure 40). Two marks are provided; one for T/C (top center) and one for 2/5 (25° BTC).

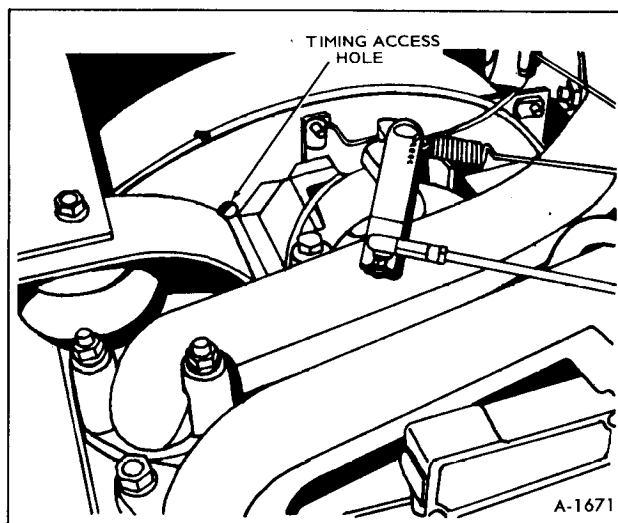

Figure 40—Timing Access Hole Location

3. Start the engine and check the timing. The 2/5 mark on the flywheel should line up in the middle of the hole.

4. Replace breaker box cover and any other hardware removed from engine.

### TIMING PROCEDURE - ENGINE NOT RUNNING - COLD SETTING

1. Connect a continuity test lamp set across the ignition breaker points. Touch one test prod to the breaker box terminal to which the coil lead is connected and touch the other test prod to a good ground on the engine.

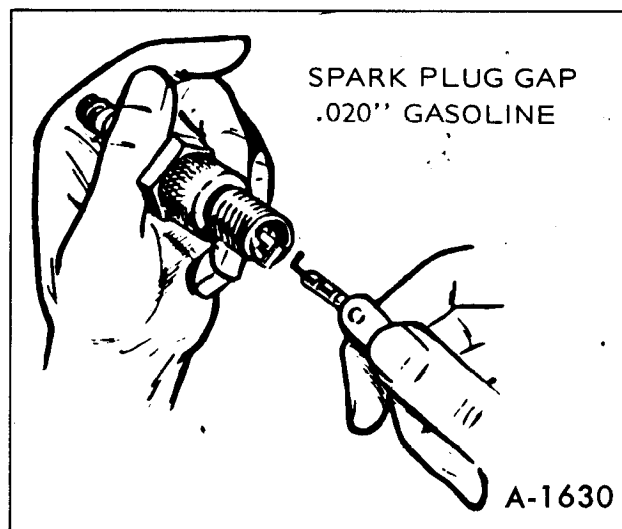

Figure 41—Checking Spark Plug Gap

2. Turn crankshaft against rotation (counter-clockwise) until the points close. Then slowly turn the crankshaft with rotation (clockwise).

3. The lamp should go out just as the points break which is the time at which ignition occurs (26° BTC - 4KW and 25° BTC - 6KW).

## SPARK PLUGS

Remove both spark plugs and install new ones every 100 hours. Use AC No. R46S or equivalent. Check to be sure spark plug gap is set at .020" as shown in Figure 41.

## IGNITION COIL

To test primary and secondary windings within the ignition coil proceed as follows:

1. Use a Simpson 260 VOM or equivalent.
2. Place black lead on ground (-) terminal of coil and red lead to positive (+) terminal. Primary resistance should read 4.30 ( $\pm 10\%$ ) ohms.
3. Change resistance setting on ohmmeter. Place ohmmeter leads inside spark plug cable holes. Secondary resistance should read 14,000 ( $\pm 10\%$ ) ohms (figure 42).
4. If any of the above conditions are not met, replace coil.

**CAUTION:** *This engine uses a 12-volt, negative ground system. Alternator must be connected to battery at all times when engine is running. Do not reverse battery cables.*

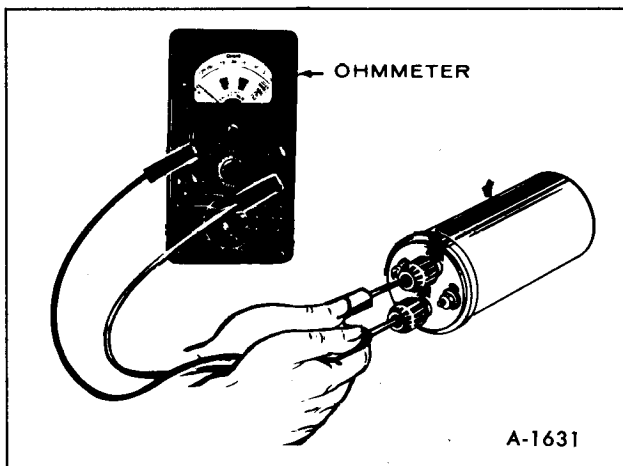

Figure 42-Coil Test

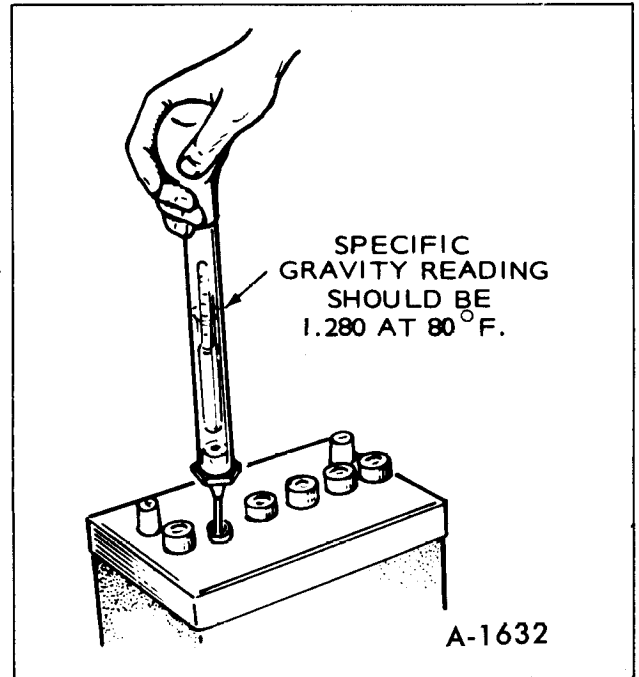

Figure 43-Specific Gravity Test

## BATTERY INSPECTION

Check battery cells with a hydrometer. The specific gravity reading should be approximately 1.280 at 80°F. (figure 43).

If one or more cells are low on water, add distilled water and recharge.

Keep the battery case clean and dry. An accumulation of moisture will lead to a very rapid discharge and battery failure.

Keep the battery terminals clean and tight. After making connections, coat the terminals with a light application of petroleum jelly or grease to retard corrosion.

## FLYWHEEL ALTERNATOR (FIGURE 44)

This unit is equipped with a permanent magnet flywheel alternator and solid-state voltage regulator-rectifier (output control). As with all solid-state electrical units, precautions are necessary when servicing. Observe the following:

### PRECAUTIONS:

1. Do not connect battery cables in the wrong polarity.

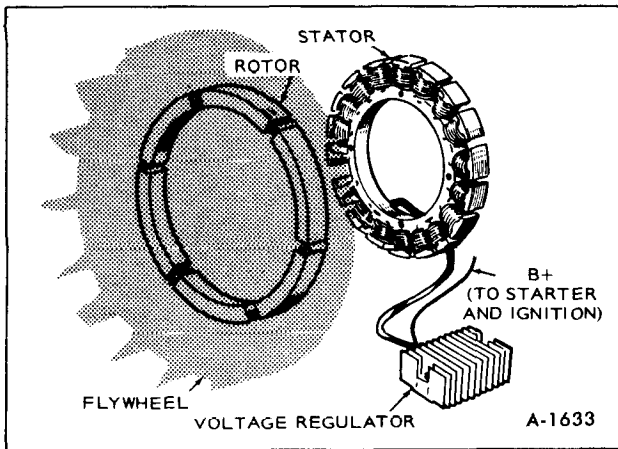

Figure 44-Flywheel Alternator System

3. Do not run without a battery. Damage will occur to regulator and battery ignition coil.

**PRESERVICE CHECKS:**

1. Check for a good ground between equipment and regulator-rectifier case.

2. Be sure output control plug (connector) is properly inserted into stator receptacle to eliminate any resistance due to a poor connection. Keep it clean and tight.

3. Check battery and its connection to be sure it is serviceable.

**NOTE:** Charging system tests require a fully charged battery.

2. Do not short together alternator stator leads.

## TESTING MOTOR GENERATOR BATTERY CHARGING SYSTEM

Basic Test	Procedure	Test Values
1. Battery	Battery Voltage - unit not running.	12 VDC
2. Regulator	Battery Voltage after unit is running 3 to 5 minutes.	13.6 to 14.7 VDC
3. Alternator Stator and Wiring with Fully Charged battery.	Ohmmeter reading from stator output - unit not running. Disconnect wire terminating at AC terminal of voltage regulator and wire terminating at BAT terminal of start solenoid. Insert AC voltmeter between these wires.	.2 to .6 Ohms
4. Alternator Stator and Wiring.	Measure AC stator output voltage with unit running. Disconnect wire terminating at AC terminal of voltage regulator. Measure AC voltage (unit running) between this wire and BAT terminal of start solenoid.	28 VAC

## STARTING SYSTEM

The starter consists of two parts: a low voltage compound DC motor and a means of transmitting motor power to the flywheel ring gear. The constructional difference between this type of starter and others is that the lever spring (figure 45) is located in the central portion of the front bracket. The shift lever, which is operated by solenoid, causes the overrunning clutch assembly to move along the armature shaft toward the flywheel. As the pinion and flywheel teeth make contact, the shift lever continues to move and make electrical contact to spin the armature. The lever spring compresses, holding the pinion gear against the flywheel gear. As soon as the armature rotates and the gear teeth line up, the gears will mesh.

### STARTER REMOVAL

**NOTE:** Starter removal requires removal of the generating set from its slide rails and mounts.

1. Remove blower scroll from front of engine by removing four screws (figure 46).
2. Remove flywheel with a flywheel puller or loosen center cap screw and direct a sharp blow to loosen. It helps to pull forward on one side of flywheel when striking with a hammer. If using this procedure be sure to leave center cap screw loosely in place or blower wheel will fall on floor.
3. Remove left and right hand air shrouds that cover cylinder heads.
4. Remove exhaust manifold.
5. Remove blower scroll backing plate (two screws on bottom – two on gear cover) as shown in Figure 47.
6. Disconnect heavy wire that connects to starter.
7. Remove two starter hold-down studs and lift out starter.

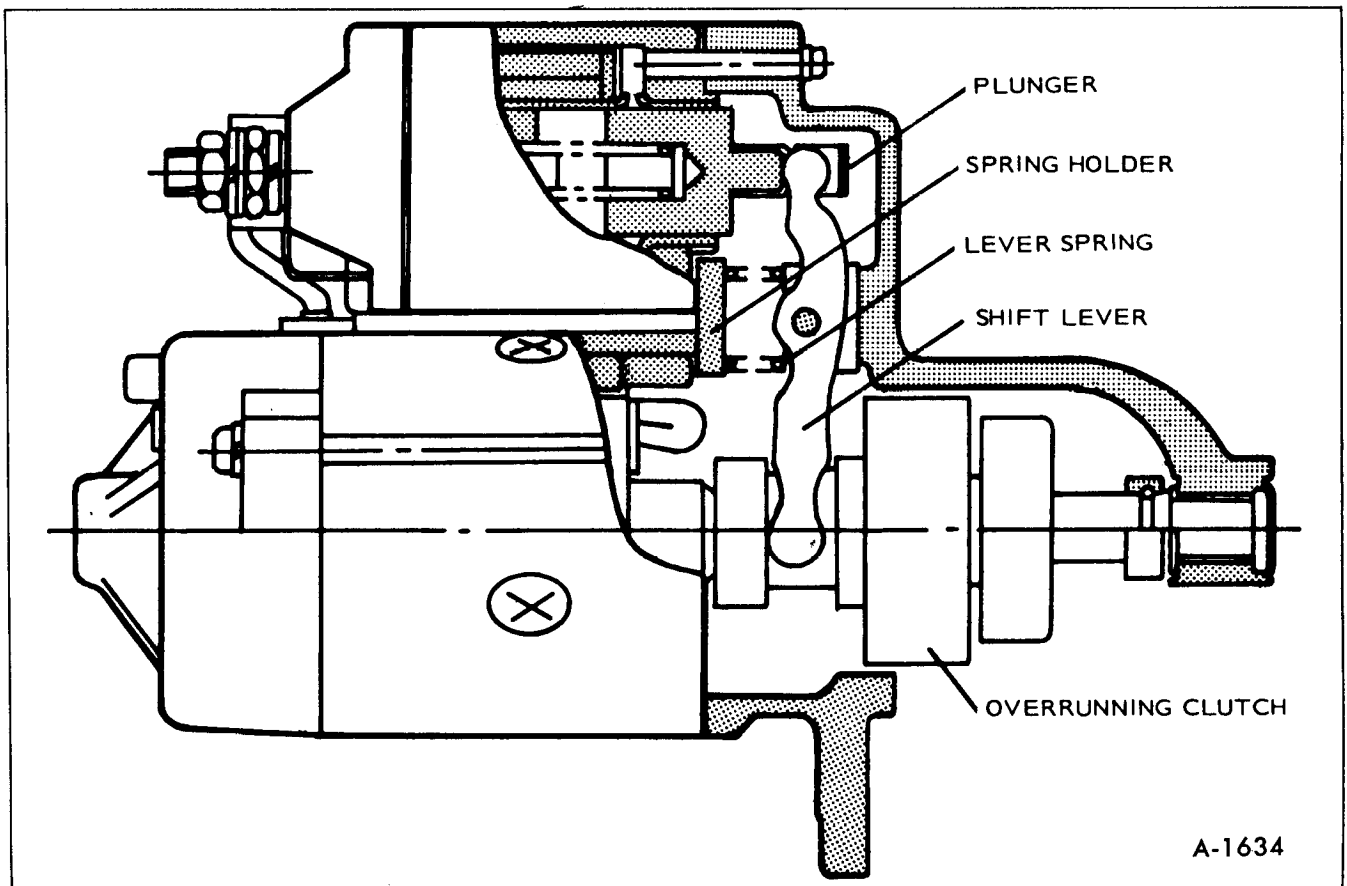

Figure 45-Starter

A-1634

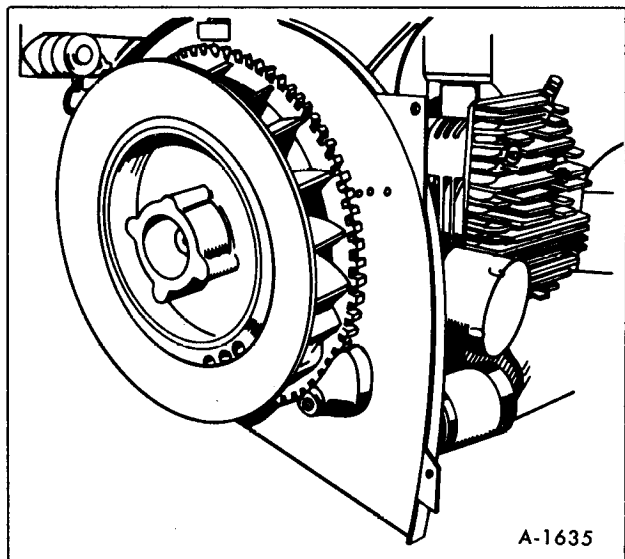

Figure 46-Blower Scroll Removed

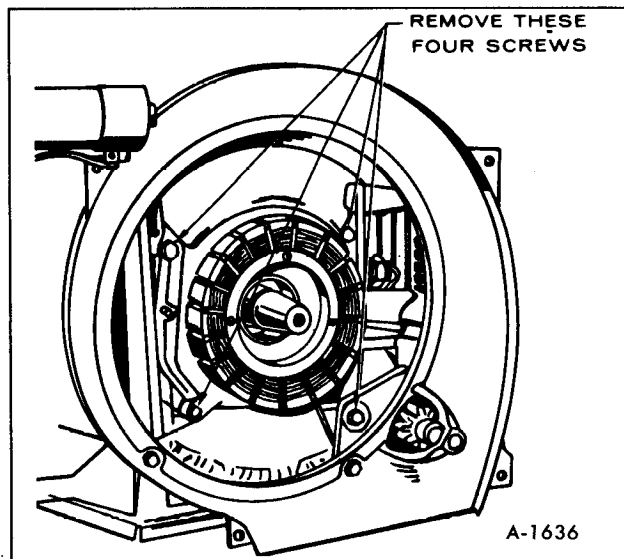

Figure 47-Removing Backing Plate

### STARTER DISASSEMBLY-4KW (FIGURE 48)

1. Loosen the nut that attaches the solenoid motor terminal to the field coil connector lead and take off the connector lead (figure 49).

2. Loosen the retaining screws and remove the solenoid from the front bracket. Simultaneously, the fiber washers, the return spring and the solenoid plunger will be removed (figure 50).

3. Unscrew the through bolts and separate the

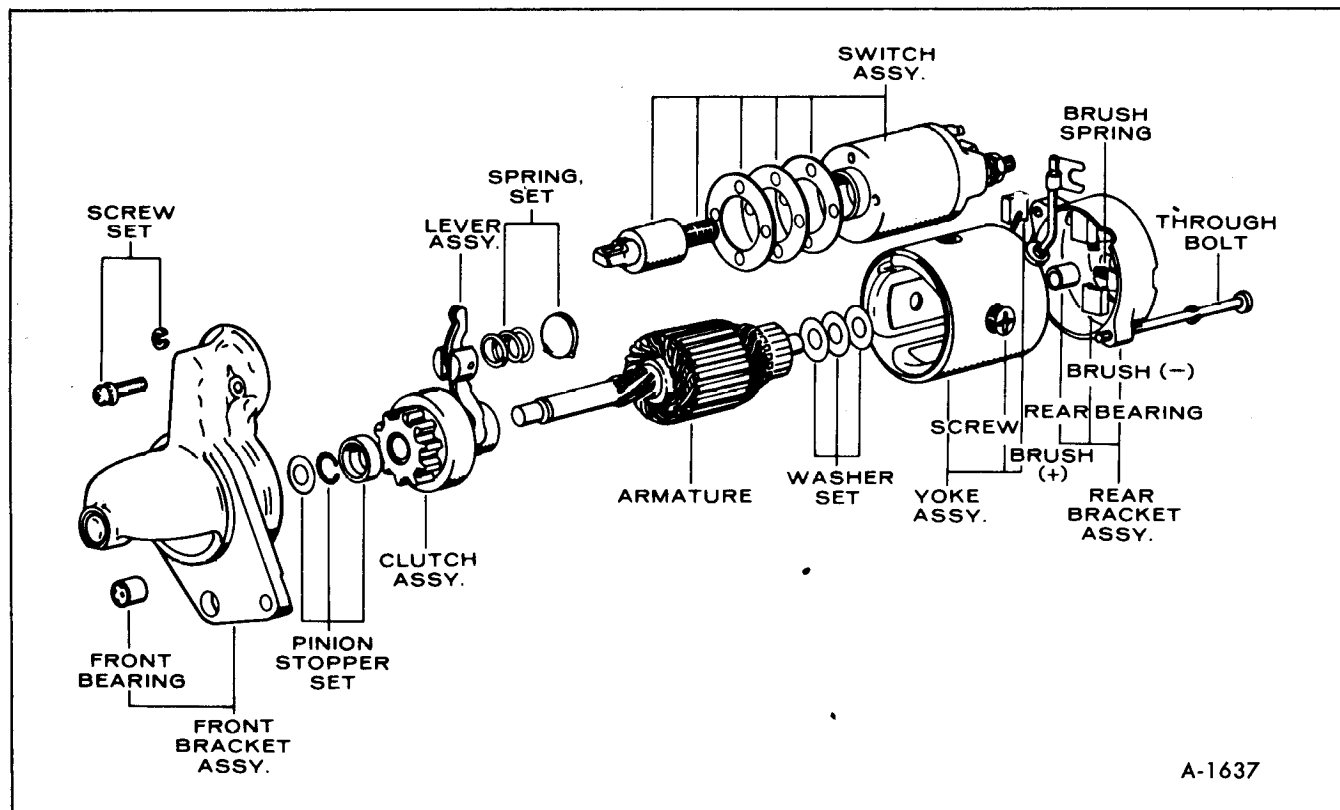

Figure 48-Starter (4KW)

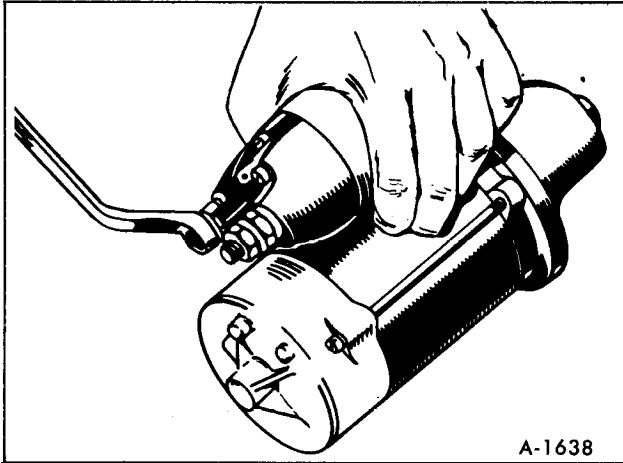

Figure 49—Removing Connector Lead

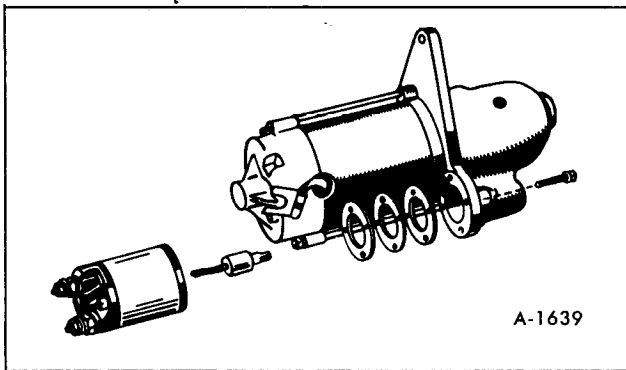

Figure 50—Removing Solenoid

yoke with the rear bracket from the front bracket (figure 51).

4. Remove the armature from the front bracket. Simultaneously, the shift lever the lever spring and the spring holder will be removed (figure 52).

5. Removing the insulated brush from the brush holder permits separation of the rear bracket from the yoke (figure 53).

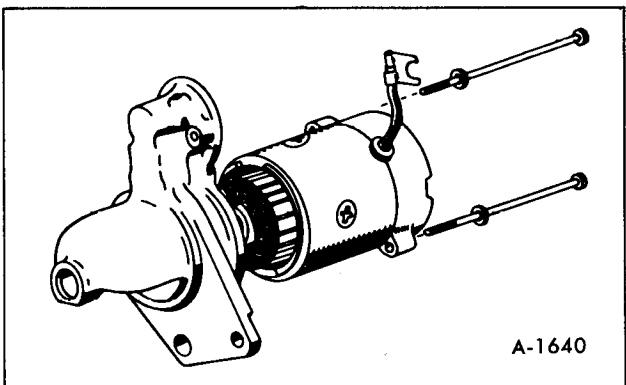

Figure 51—Removing Yoke

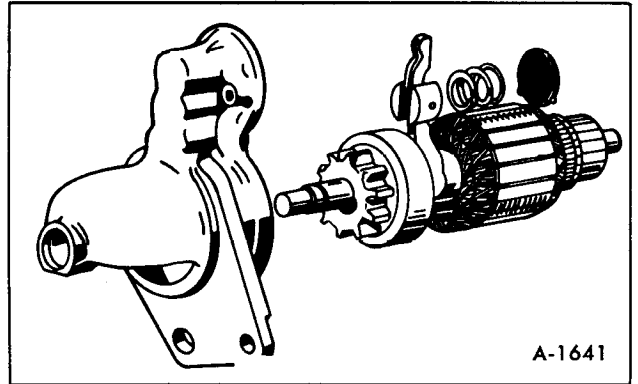

Figure 52—Removing Armature

6. If it is necessary to remove overrunning clutch, first, put a metal cylinder of suitable size over the end of armature shaft so it rests on the stop ring. Then tap the cylinder lightly with a hammer, the stop ring towards armature and lock ring. Remove ring from groove in shaft so the overrunning clutch and the stop ring will be removed from the armature shaft.

### STARTER DISASSEMBLY - 6KW (FIGURE 54)

After removing the starter from the engine, disassemble as follows:

1. Loosen the nut that attaches the solenoid motor terminal to the field coil connector lead and take off the connector lead (figure 49).

2. Loosen the retaining screws and remove the solenoid from the front bracket. Simultaneously, the fiber washers, the return spring and the solenoid plunger will be removed (figure 50).

3. Unscrew the through bolts and the screws attaching the brush holder assembly to the rear bracket, so the rear bracket will be removed from the yoke.

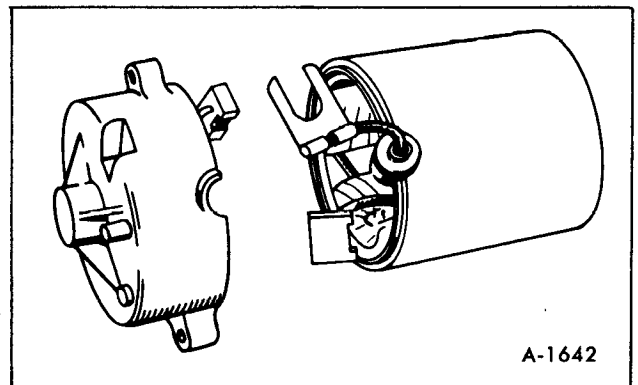

Figure 53—Separating Yoke and Rear Bracket

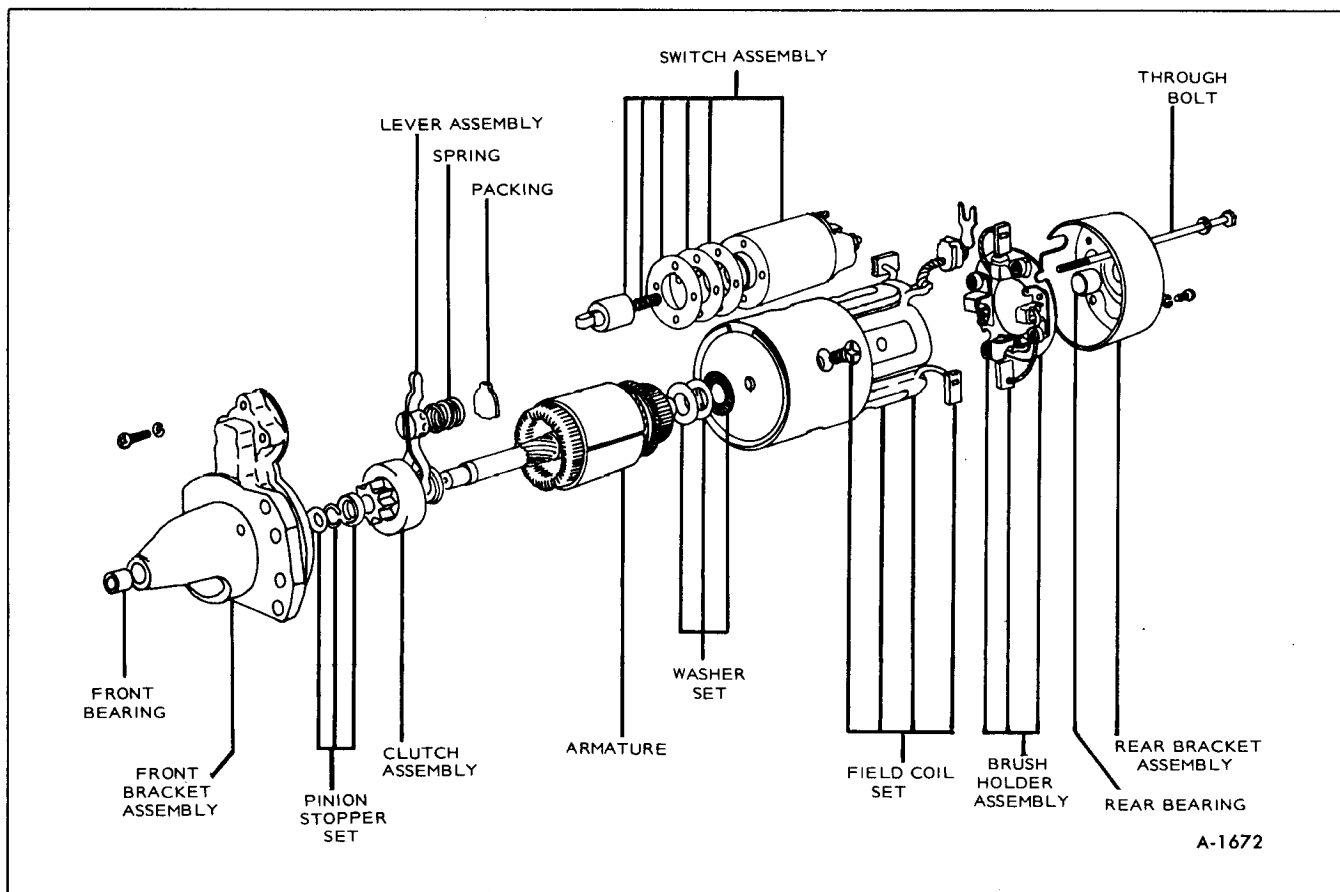

Figure 54—Starter (6KW)

4. Remove the yoke with the brush holder assembly.

5. Removing the brushes from the brush holders permit separation of brush holder assembly from the field coil.

6. Remove the armature from the front bracket. Simultaneously, the shift lever, the lever spring and the spring holder will be removed.

7. To remove the overrunning clutch, put a metal cylinder of suitable size over the end of armature shaft so it rests on the stop ring. Tap cylinder lightly with hammer, the stop ring sliding toward armature and off ring. Remove the ring from groove in shaft and then slide the overrunning clutch and the stop ring from the armature shaft.

**CAUTION:** Do not immerse parts in cleaning solvent. Immersing the field coil, yoke assembly, armature and solenoid will damage the insulation. Wipe these parts with a cloth only. Do not immerse the overrunning

*clutch in cleaning solvent. The clutch is prelubricated at the factory, and solvent will wash lube from clutch. Wash all other parts in solvent and dry the parts.*

## INSPECTION OF PARTS

**GROUNDING ARMATURE:** Use a 120 volt test lamp set for testing armature for grounds as shown in Figure 55. If lamp lights when one probe of test lamp is touched to commutator with other probe to the core, the armature is grounded and must be replaced.

**SHORTED ARMATURE:** (figure 56) Use a growler tester for testing armature for a short circuit. Place armature in growler and hold a thin, steel blade (hacksaw blade) parallel to the core and just above it while slowly rotating armature in growler. A shorted armature will cause blade to vibrate and be attracted to the core.



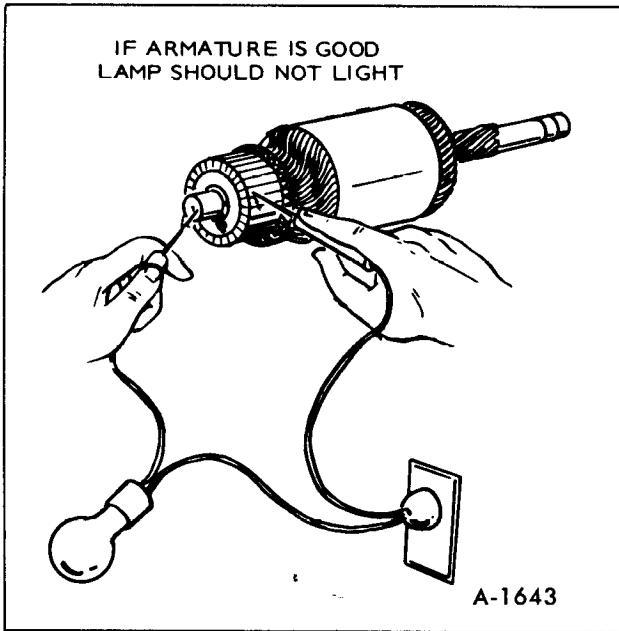

Figure 55-Testing for Grounded Armature

**OPEN ARMATURE:** The most likely place to check for an open circuit is at the commutator riser bars. Inspect for loose connections on points where the conductors are joined to the commutator bars.

**COMMUTATOR RUNOUT:** Place armature in a pair of v-blocks and measure runout with a dial indicator refer to Figure 57. Measure both shaft and commutator. A bent shaft requires replacement of armature. When runout exceeds a .004 inch, com-

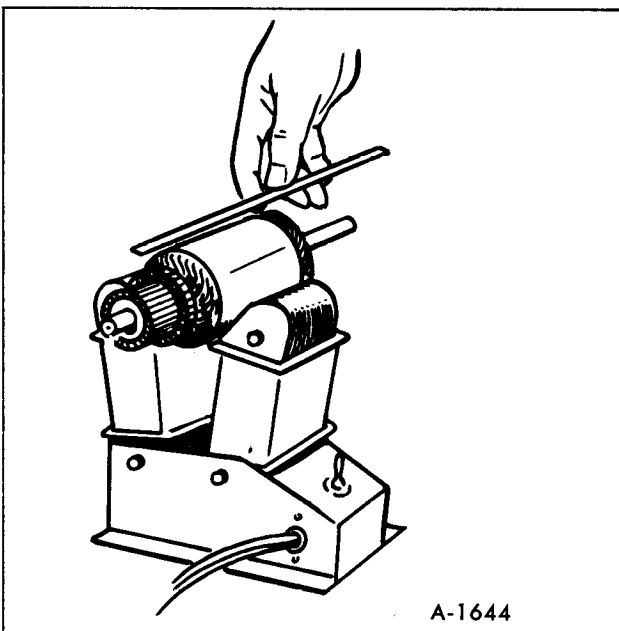

Figure 56-Testing for a Short Circuit

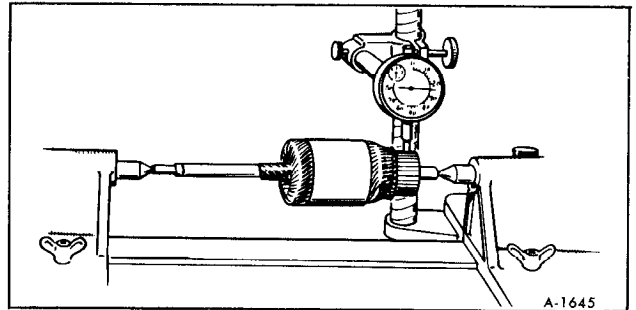

Figure 57-Testing Commutator Runout

mutator should be refaced. Remove only enough metal to provide a smooth, even surface.

**OPEN FIELD COIL:** Use a 120 volt test lamp set for this test. Connect one probe of test lamp to the yoke and the other probe to insulated brush. If lamp does not light, the field coil is open.

**NOTE:** This starter is compound wound, having a series coil and a shunt coil. The grounded end of the shunt coil is soldered inside of the yoke.

**GROUNDING FIELD COIL:** Use a 120 volt test lamp set for testing for a grounded field coil. First disconnect the grounded end of shunt coil as shown in Figure 58. Then connect one probe of test lamp to yoke and the other probe to field coil connector lead. If lamp lights, field coil is grounded.

**BRUSH REPLACEMENT:** Brushes that are worn out to the wear limit line should be replaced as shown in Figure 59. Brushes can be replaced after removing the rear bracket.

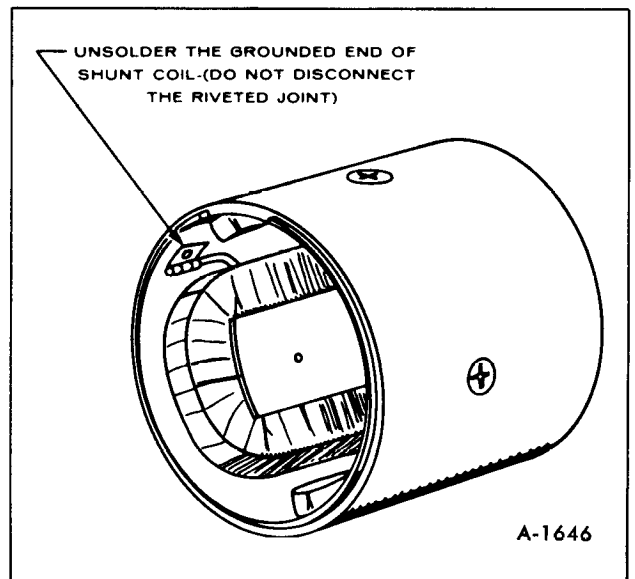

Figure 58-Testing Field Coil

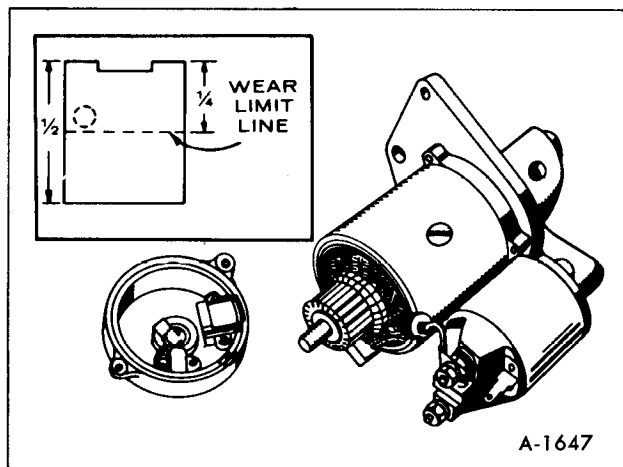

Figure 59—Brush Replacement

When resoldering the brushes, make a low resistance connection, using a high temperature solder and resin flux.

**BRUSH SPRINGS:** The spring tension should be taken using a push-type spring scale until the top of a new brush protrudes 1/16 inch from the brush holder. Spring tension should be 36 to 48 ounces. See Figure 60.

**OVERRUNNING CLUTCH:** The pinion gear should rotate smoothly in one direction (not necessarily easily), but should not rotate in opposite direction. If pinion gear does not function properly, or if

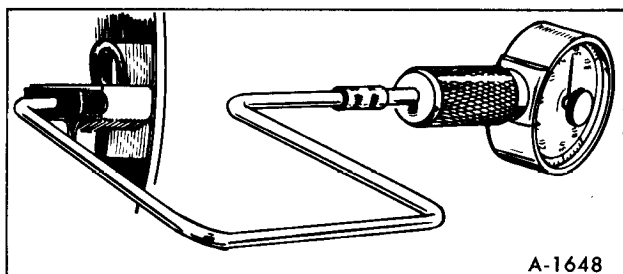

Figure 60—Testing Brush Spring Tension

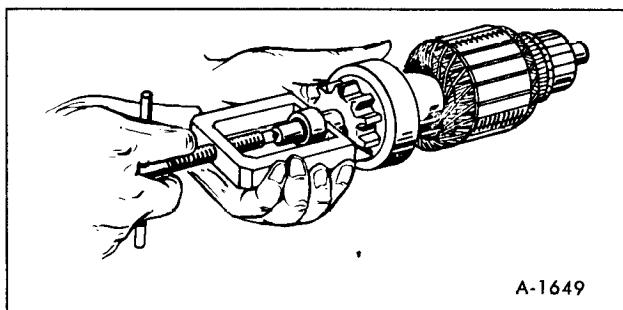

Figure 61—Installing Overrunning Clutch

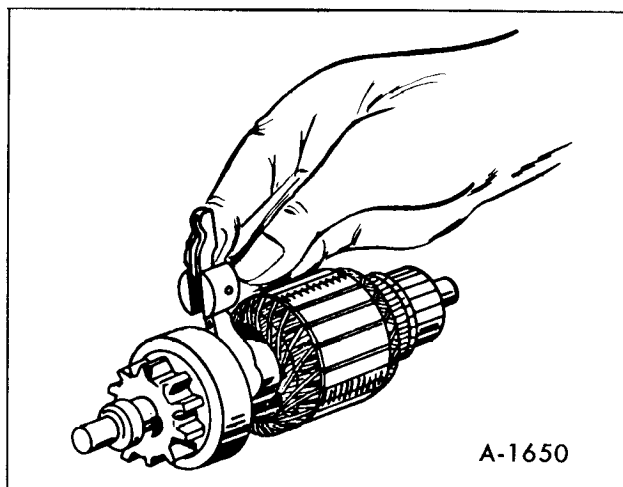

Figure 62—Installing Shift Lever

pinion gear is worn or burred, replace the overrunning clutch.

## ASSEMBLY-4KW

1. Lubricate armature shaft and splines with a very light grade oil. A medium or heavy oil and grease may cause the overrunning clutch assembly faulty operation in cold weather.

2. Install the overrunning clutch assembly, the ring and the stop ring on the armature shaft. Drive pinion stopper far enough on shaft to install stopper ring. Then using a puller (figure 61) pull stopper against ring.

3. Apply a small amount of lubricate on the shift lever pivot pin and lever holders.

Install the shift lever over the clutch assembly with position indicated in Figure 62. This is important, if the shift lever is not properly positioned the pinion gear travel will be restricted causing a locking in the clutch mechanism.

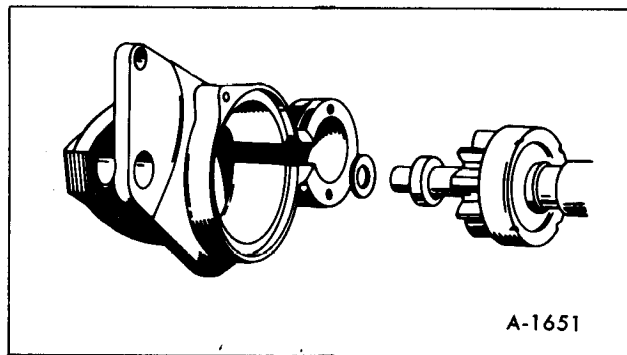

Figure 63—Installing Front Bracket

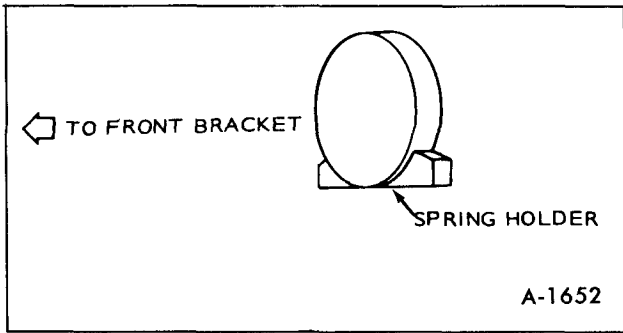

Figure 64—Spring Holder Placement

4. Place the thrust washer on the drive end of the shaft. Slide the armature with the lever into the front bracket (figure 63).

5. Place the lever spring and the spring holder into the front bracket with the direction shown in Figure 64.

6. Position the Yoke to the front bracket. Be sure that the yoke is properly indexed to the front bracket (figure 65).

7. Place the thrust washer (steel) and washer (fiber) on the commutator end of shaft, and apply a small amount of lubriplate on the shaft (figure 66).

**NOTE:** In case three washers are used, the fiber washer is placed between the steel washers.

8. Insert two brushes and springs in their brush holders and push them against spring tension.

Secure the brushes by iron wires as shown in Figure 67.

9. When securing the brushes, position the rear bracket to the yoke, inserting the rubber gasket to the slot of the rear bracket. After the rear bracket is

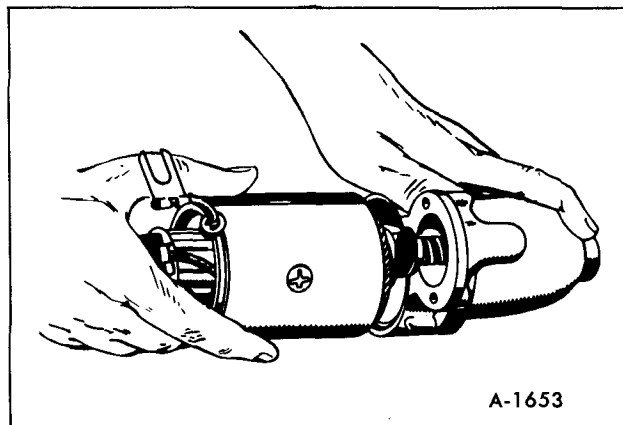

Figure 65—Yoke to Front Bracket Installation

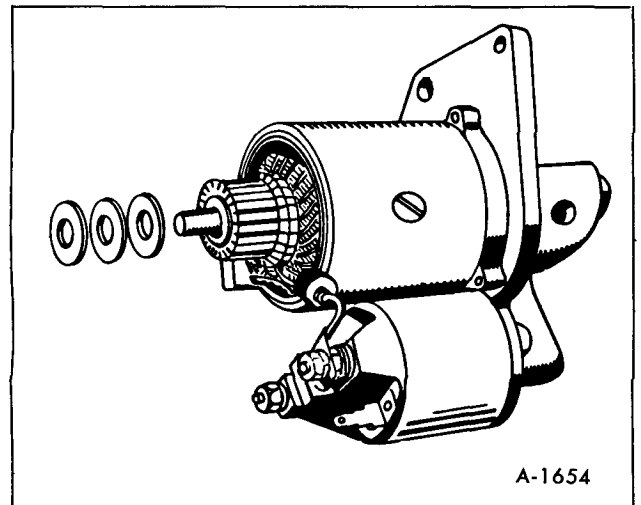

Figure 66—Installing Thrust Washers

installed to the yoke, withdraw iron wires so the brushes and the commutator come in contact. Then, insert the bushings into the holes to keep out dirt.

10. Fasten through bolts securely.

11. Install the solenoid plunger over the top of the shift lever in the front bracket as shown in Figure 68. Be sure that the pinion gear is moved when the plunger is pulled manually.

12. Install the solenoid.

**IMPORTANT:** The return spring, in this case, should be straight in the proper position between

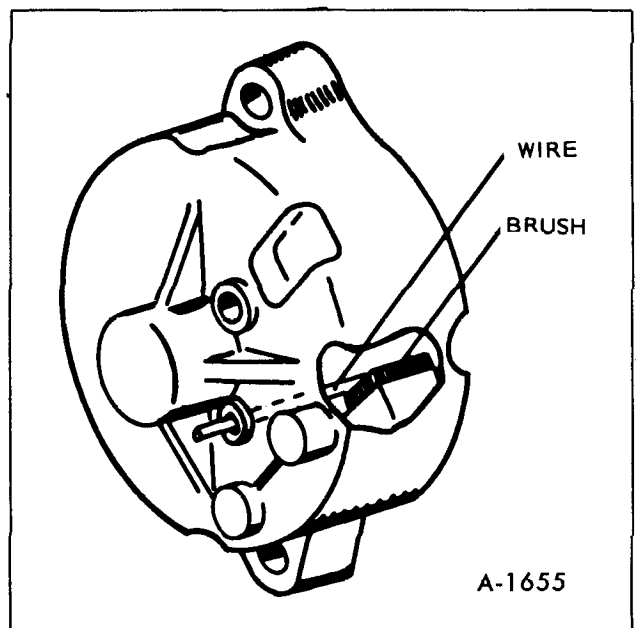

Figure 67—Brush Installation

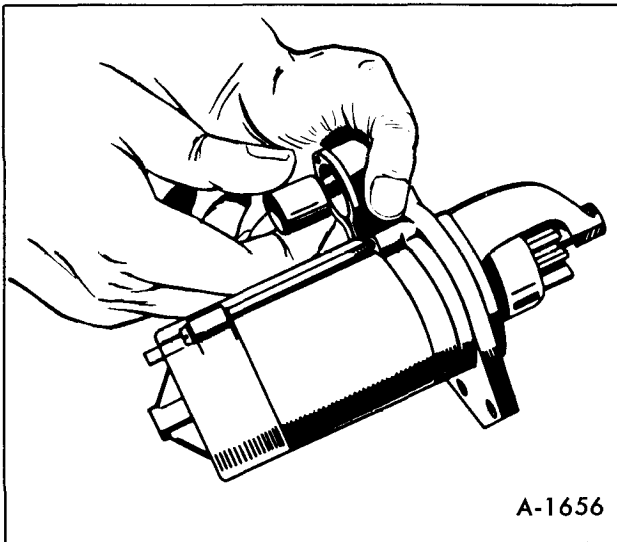

Figure 68—Installing Solenoid Plunger

the bore of the solenoid and the bore of the plunger.

## ASSEMBLY - 6KW

1. Lubricate armature shaft splines with a very light grade oil. A medium or heavy oil and grease may cause the overrunning clutch assembly faulty operation in cold weather.

2. Install the overrunning clutch assembly, the ring and the stop ring on the armature shaft.

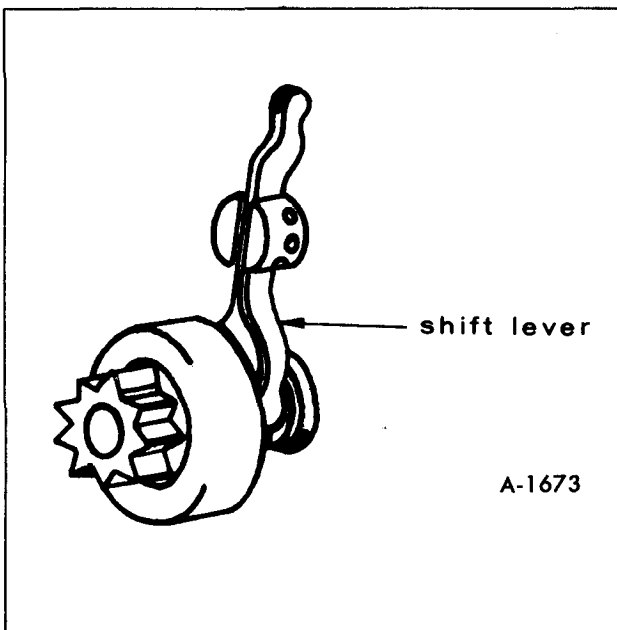

Figure 69—Shift Lever

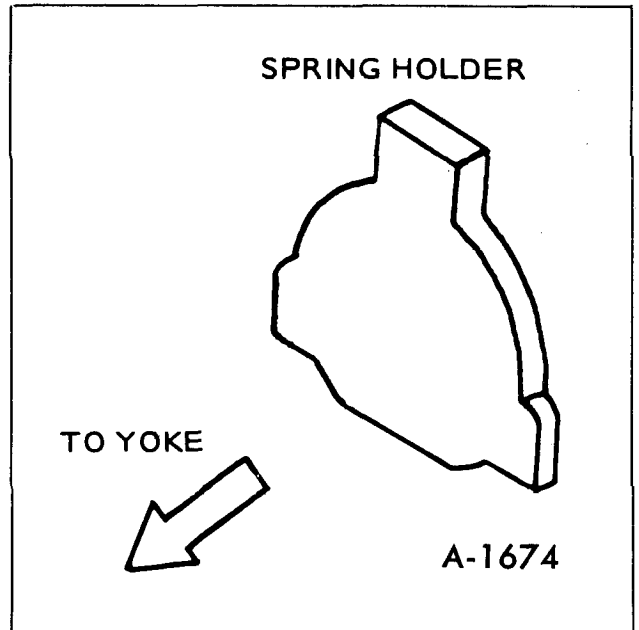

Figure 70—Spring Holder

3. Apply a small amount of lubriplate on the shift lever pivot pin and the lever holders.

Install the shift lever over the clutch assembly with position as indicated in Figure 69. This is important, if the shift lever is not properly positioned the pinion gear travel will be restricted causing a locking in the clutch mechanism.

4. Apply a film of medium engine oil to the drive end of the armature shaft.

Place the thrust washer on the drive end of the shaft. Slide the armature with the lever into the front bracket.

5. Place the lever spring and the spring holder into the front bracket in the direction shown in Figure 70.

6. Before installing the yoke, note the position of the holes of front bracket in which the through bolts are fastened. Position the yoke to the front bracket. Be sure that the yoke is properly indexed to the front bracket.

7. Position the brush holder assembly indexing the cuts of the brush plate to the holes of the front bracket.

8. Install the brushes in their brush holders. Be sure to center the brush springs on the brushes.

9. Place the thrust washers on the commutator end of the armature shaft and apply a small amount of lubriplate on the shaft.

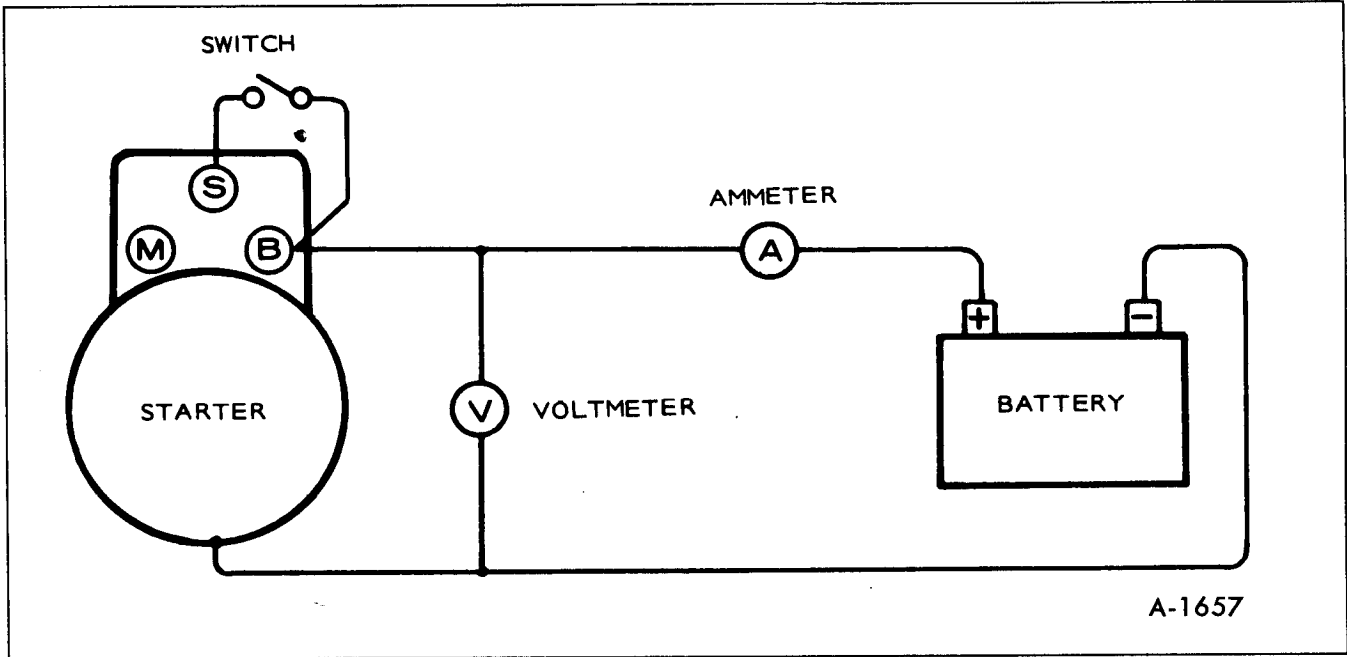

Figure 71—No Load Test

**NOTE:** The fiber washer is placed between the steel washers.

10. Position the rear bracket to the yoke, inserting the rubber gasket to the slot of the rear bracket.
11. Align the holes in brush plate with holes in the rear bracket and install two screws attaching the brush holder assembly to the rear bracket.
12. Fasten through bolts securely.
13. Install the solenoid plunger over the top of the shift lever in the front bracket. Be sure that the pinion gear is moved when the plunger is pulled manually.
14. Install the solenoid.

**NOTE:** The return spring, in this case, should be straight in the proper position between the bore of the solenoid and the bore of the plunger.

## TESTING AND ADJUSTING STARTER

ADJUSTING PINION CLEARANCE: After

4KW:

BATTERY VOLTAGE ..... 11.5 Volts  
 MINIMUM RPM ..... 6000 RPM  
 MAXIMUM CURRENT DRAW ..... 55 Amps

6KW:

BATTERY VOLTAGE ..... 10.5 Volts  
 MINIMUM RPM ..... 5000 RPM  
 MAXIMUM CURRENT DRAW ..... 53 Amps

the starter is reassembled the pinion clearance must be adjusted to give sufficient clearance between the end of the pinion and the stop ring when the pinion is in mesh with the ring gear of the engine.

1. Connect a battery of the proper voltage between the "Switch" terminal of the solenoid and the bracket of the starter (ground), so the pinion will travel.
2. Then, push the pinion back until play is taken out of the lever and the clutch mechanism.
3. Measure the pinion clearance.
4. The clearance should be 0.02 to 0.08 inch. Adjust by removing the solenoid and increasing or decreasing the number of the fiber washers.

**NOTE:** Increasing the number of the washers decreases clearance, and decreasing the number of the washers increases clearance.

**NO LOAD TEST:** For this test connect starter as shown in Figure 71. The values of this test should be as follows:

**CAUTION:** Before installing the starter, be sure starter and engine mounting surfaces are free of dirt and oil. These surfaces must be clean to make a good electrical contact. Don't operate the starter more than 30 seconds, or serious damage may result. Starters are not designed for continuous operation.

When the engine does not rotate, don't hold the starter in a stall condition more than 10 seconds. The wires between the battery and the starter should be of sufficient size to carry the electric load without excessive voltage drop.

## AC GENERATOR

The generator uses a revolving armature and normally needs little care other than a periodic check of the brushes and collector rings.

**NOTE:** All accessories must be taken off and power plant must be removed from its slide rails for disassembly and repair of the generator.

### BRUSH REPLACEMENT

To gain access to brushes, remove plastic end bell screens. Measure brush wear as shown in Figure 72. Using a small, narrow scale inserted into top of brush block. If brushes need replacing remove and tag wires connecting to brush blocks. Then remove brush blocks and lift out of end bell. Pull out the brushes and springs from bottom of brush block. Clean out any dirt or oil from brush block at this time.

New brushes are shaped to fit and seldom need sanding to seat properly. Always replace brushes as a set. Never use a substitute brush which may appear to be the same but may have entirely different electrical characteristics.

Note that brush blocks are stamped "BRG END" on one side. Be sure this stamped side faces bearing end of generator for correct brush alignment. Tighten the brush block screws to 40 – 70 in.-lb. (4-6 ft.-lb.) If some sparking occurs after replacing brushes, run the plant with a light load until brushes seat properly. Check brush springs for freedom of movement.

### GENERATOR DISASSEMBLY (FIGURE 73)

1. Remove power plant from its slide rails.

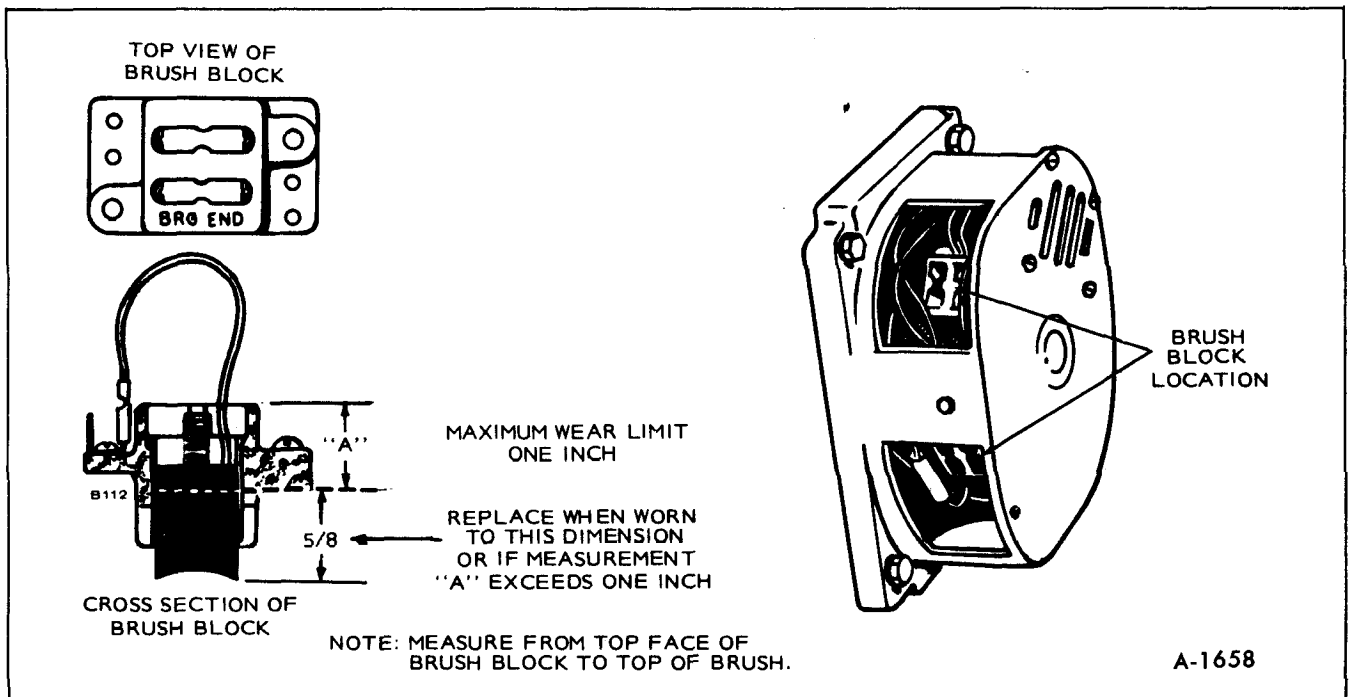
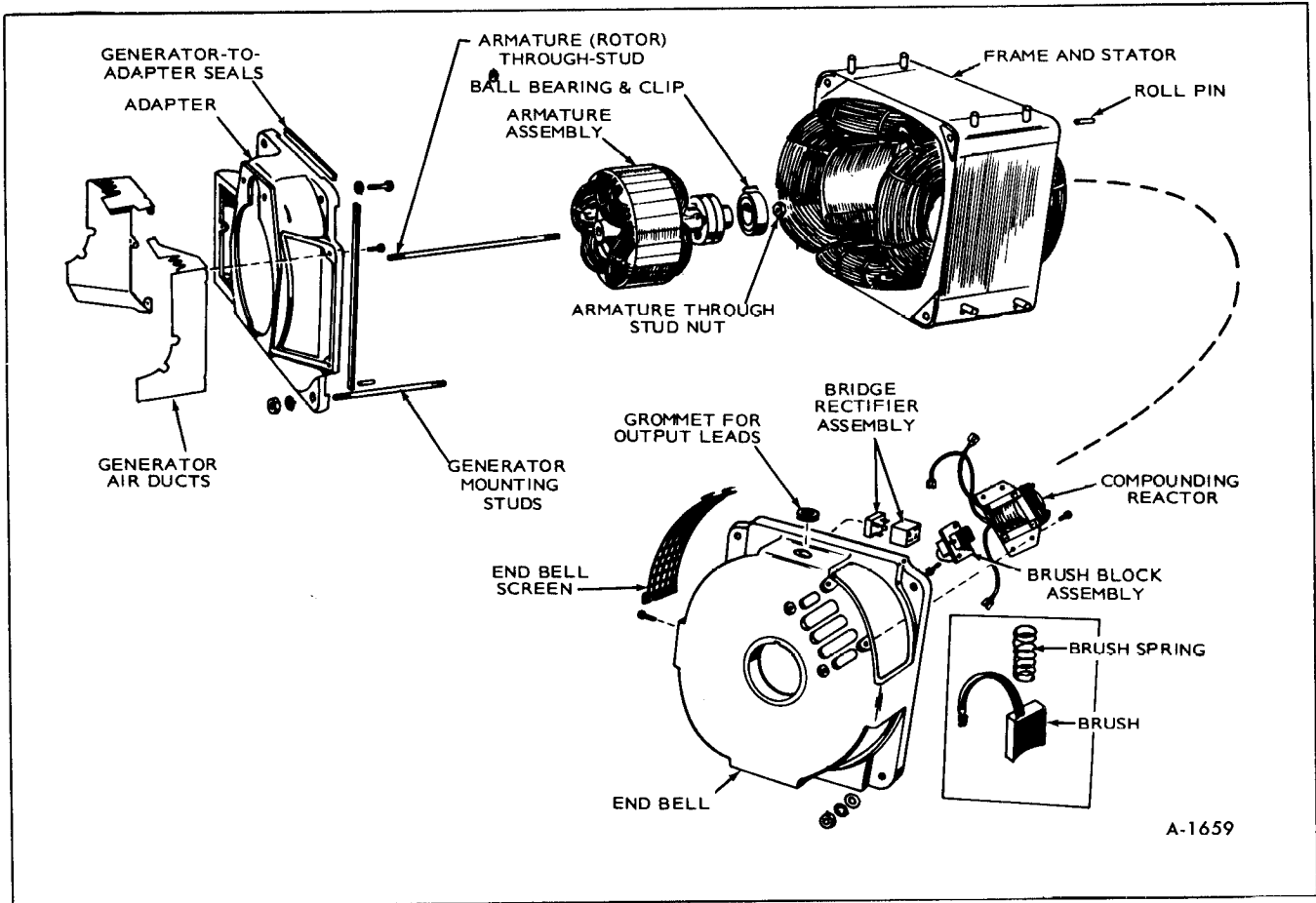

Figure 72-Brush Wear Limits



A-1659

Figure 73-Generator Components

2. Remove all accessories attached to the generator.
3. Tag and remove all leads.
4. Loosen and lift out both brush rigs.
5. Remove four generator through-stud nuts.
6. Lift or pull end bell from frame assembly. Do not pry loose with a screwdriver, use a plastic hammer and tap around edges of end bell to loosen.
7. Remove frame (field) assembly, being careful not to let it rest or drag on the armature.

**CAUTION:** Four seals are used between frame (field) assembly and engine-to-generator adapter. These seals must be installed when reassembling generator or the generator will overheat.

8. Using a square 3/8-inch drive, insert into 12-point (internal wrenching) armature hold-down nut and remove.

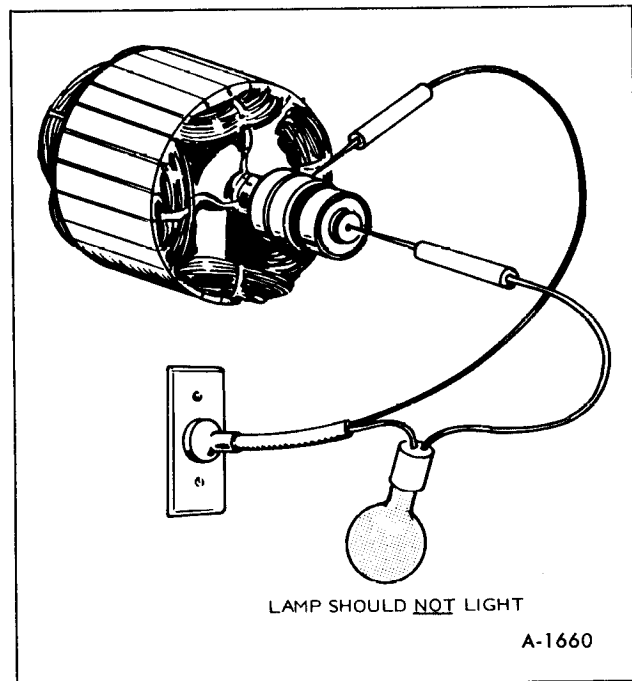

A-1660

Figure 74-Armature Ground Test

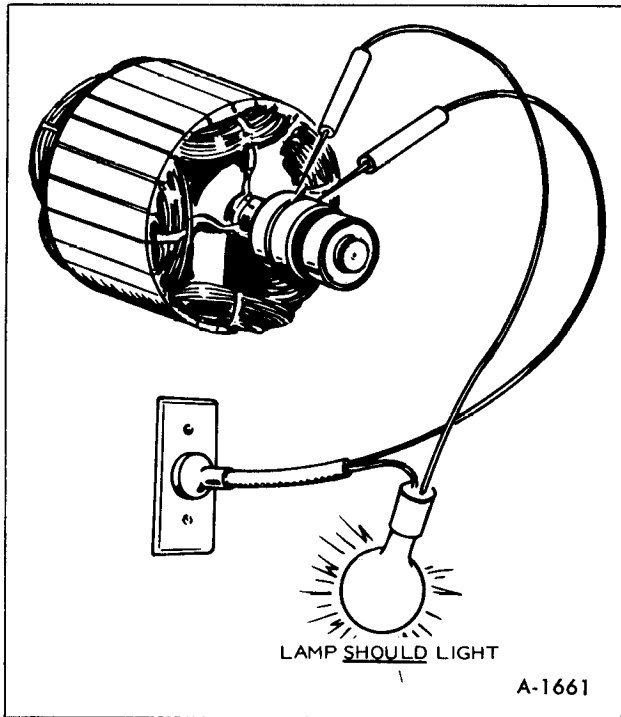

Figure 75—Armature Open Test

9. While pulling outward with one hand under the armature, strike a sharp end-wise blow on armature shaft to loosen armature. The armature has an internal taper which fits onto the external taper of engine adapter. If the armature does not come loose, place a heavy brass rod on the armature shaft near the ball bearing and strike a sharp downward blow on the rod with a hammer. Rotate the armature 1/2 turn before repeating.

**CAUTION:** Do not strike the collector rings or bearing.

## GENERATOR TESTING AND REPAIR

### ARMATURE GROUND TEST

Use a 120-volt series test lamp set for this test. Armature must be removed from generator for this test.

Place one test prod on one of the collector rings and the other test prod on the armature shaft. Test lamp should not light. If the test lamp lights, the AC winding or a collector ring is grounded to the shaft. Test both collector rings in this manner, refer to Figure 74.

### ARMATURE OPEN TEST (FIGURE 75)

Use a 120-volt series test lamp set for this test. Place one prod on each collector ring. The test lamp should light. If lamp does not light, armature is open and must be replaced.

### TESTING FIELD WINDINGS FOR GROUNDS (FIGURE 76)

To test the field assembly for grounds, disconnect

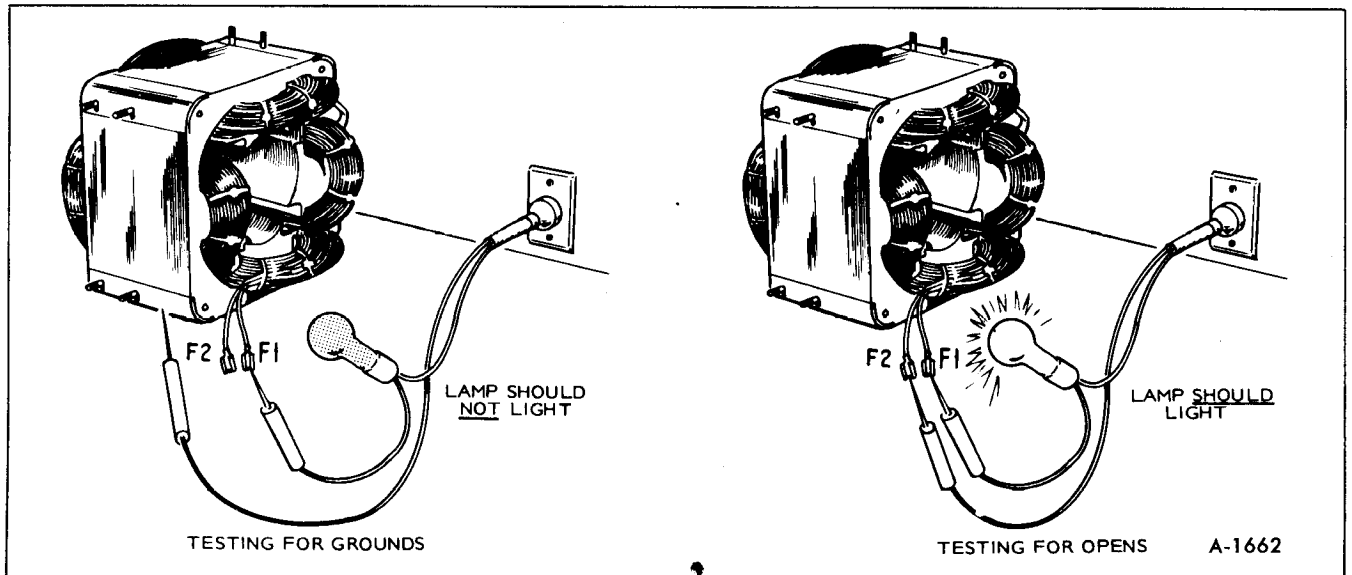

Figure 76—Testing Field Windings



all field leads and use a 120-volt series test lamp set. Touch one prod to F1 (+) and the other prod to the frame. Lamp should not light. If lamp lights, field is grounded and must be replaced. (Test F2 lead in the same manner.)

### TESTING FIELD WINDINGS FOR AN OPEN CIRCUIT (FIGURE 76)

For this test use either an ohmmeter or a 120-volt series test lamp set.

Using an Ohmmeter: Disconnect external leads and connect ohmmeter leads to F1 (+) and F2 (-). Resistance in the windings should read 28.8 ohms ( $\pm 3\%$ ) at 70 F.

Using a Test Lamp Set: Disconnect external leads and touch test prods to F1 and F2. The lamp should light. If not, field winding is open and must be replaced.

Check terminal ends closely for loose connec-

tions. These can be fixed easily without replacing the whole assembly.

### TESTING BRIDGE RECTIFIER

To accurately test bridge rectifier proceed as follows:

1. Loosen No. 8-32 screw to remove bridge rectifier assembly (See figure 77 for location).
2. Disconnect the nylon connector from bridge rectifier assembly, noting the polarity marking of bridge rectifier assembly and connector.
3. Pull out from end bell and remove bridge rectifier from its case.

**CAUTION:** Note that connector can only be mounted in one direction.

4. Use an ohmmeter to test bridge rectifier. Set the ohmmeter dial to R x 1 scale.

5. Now place meter leads on points shown in Figure 78 and note readings from following table:

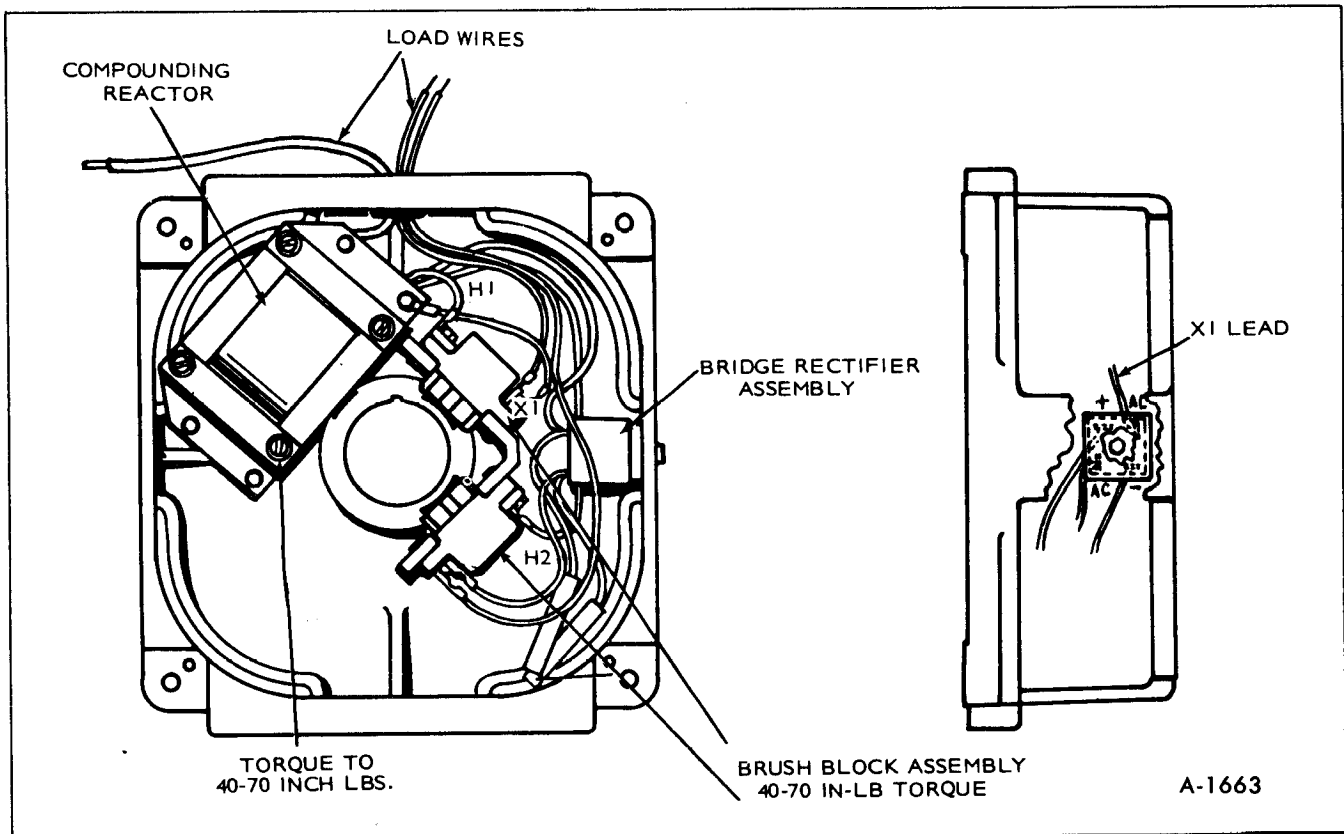
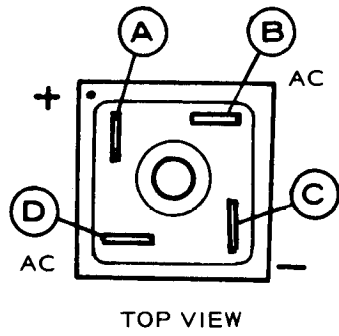
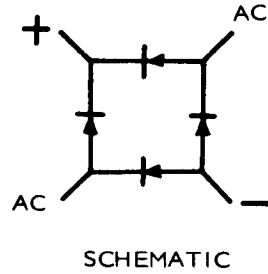

Figure 77-End Bell Assembly

A-1663



NOTE: RED MARK APPEARS NEAR "+" LEAD.



A-1664

Figure 78-Testing Bridge Rectifier

BLACK LEAD	RED LEAD	RE-SISTANCE
A	B	*8 ohms
A	D	*8 ohms
B	C	*8 ohms
D	C	*8 ohms
B	A	
D	A	
C	B	
C	D	

bridge rectifier and nylon case. Observe proper polarity when installing. If installed wrong, generator voltage will not build up.

### COLLECTOR RINGS

Collector rings acquire a glossy brown finish in normal operation. Do not attempt to maintain a bright, newly machined appearing surface. Ordinary cleaning with a dry, lint-free cloth is usually sufficient. Very fine sandpaper (#00) may be used to remove slight roughness. Use only light pressure on the sandpaper, while the plant is running. Do not use emery or carborundum paper or cloth. Clean out all carbon dust from the generator.

\*  $\pm 10\%$  - Readings taken at 70 F.

6. If any tests do not agree with the above readings, install a new bridge rectifier.

**CAUTION:** All terminals are marked on both

WITH ONE AMPERE INPUT THE VOLTAGE SHOULD READ

	VOLTAGE
4KW (315-380)	65-75
6KW (315-378)	60-70

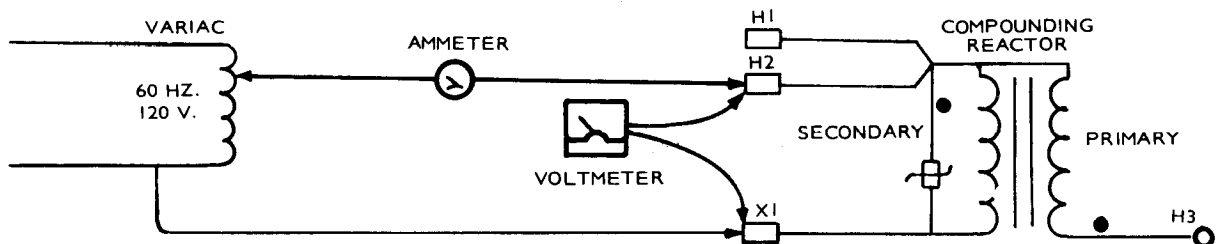

A-1665

Figure 79-Testing Compounding Reactor

## GENERATOR BEARING

The generator is prelubricated and double-sealed. Replace bearing approximately every 5 years or at each engine overhaul.

## COMPOUNDING REACTOR

If output voltage is high with no electrical load connected to the generator, with generator running at 1800 rpm, then the compounding reactor is probably defective. Test as shown in Figure 79, using a Variac.

# CONTROLS

## OPERATION (FIGURE 80)

### STARTING:

Push start switch S3. Battery current flows thru K1 solenoid, K2 contacts and start switch S3 to battery negative (GND). K1 solenoid closes contacts, feeding current to starter motor and to choke

E1 plus K3 relay. K3 relay contacts close the circuit to the ignition coil and fuel pump. The engine cranks and the fuel pump and ignition operate to start the engine. The remote start switch is connected as shown in Figure 81.

**NOTE:** For details on control panel, refer to figures 82 and 83.

### ENGINE STARTS:

When the starting rpm increases, the alternator develops a voltage great enough to be rectified and energize relay K2. Relay K2 contacts close to hold relay K3 energized, and K2 normally closed contacts open to drop K1 start solenoid. K3 contacts maintain current to ignition coil and fuel pump. The engine continues running and K2 remains energized.

### STOP ENGINE:

Relay K3, energized by K2, maintains ignition. To stop engine, push the stop switch which shorts out K3. Relay K3 drops out to remove power from the fuel pump and ignition coil. Resistor R2 absorbs the power that was supplied to K3 during the period the stop switch is held close as the engine slows to a stop.

### LOW OIL PRESSURE SHUTDOWN:

The control has a built-in time delay of 2 to 4 seconds for a low oil pressure shutdown. If a low oil pressure condition occurs, the low oil pressure switch S2 closes to charge capacitor C3 through resistor R3. When the voltage on capacitor C3 matches the voltage of the divider R5-R6, the programmable unijunction transistor Q1 "fires" to trigger CR8. CR8 turns on to de-energize K3 relay. K2 contacts open as the engine stops and CR8 turns off.

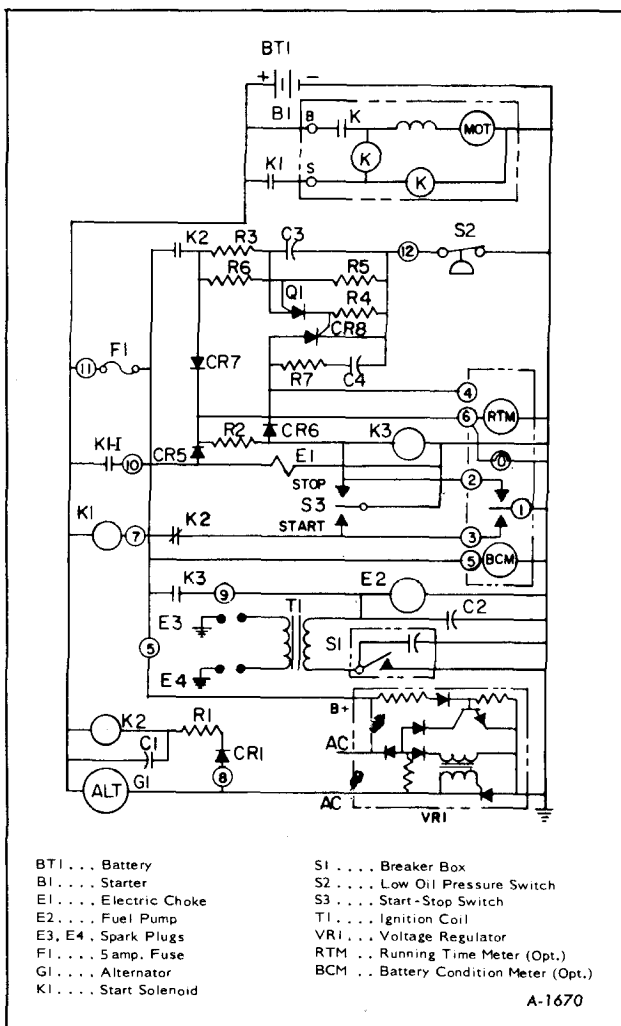
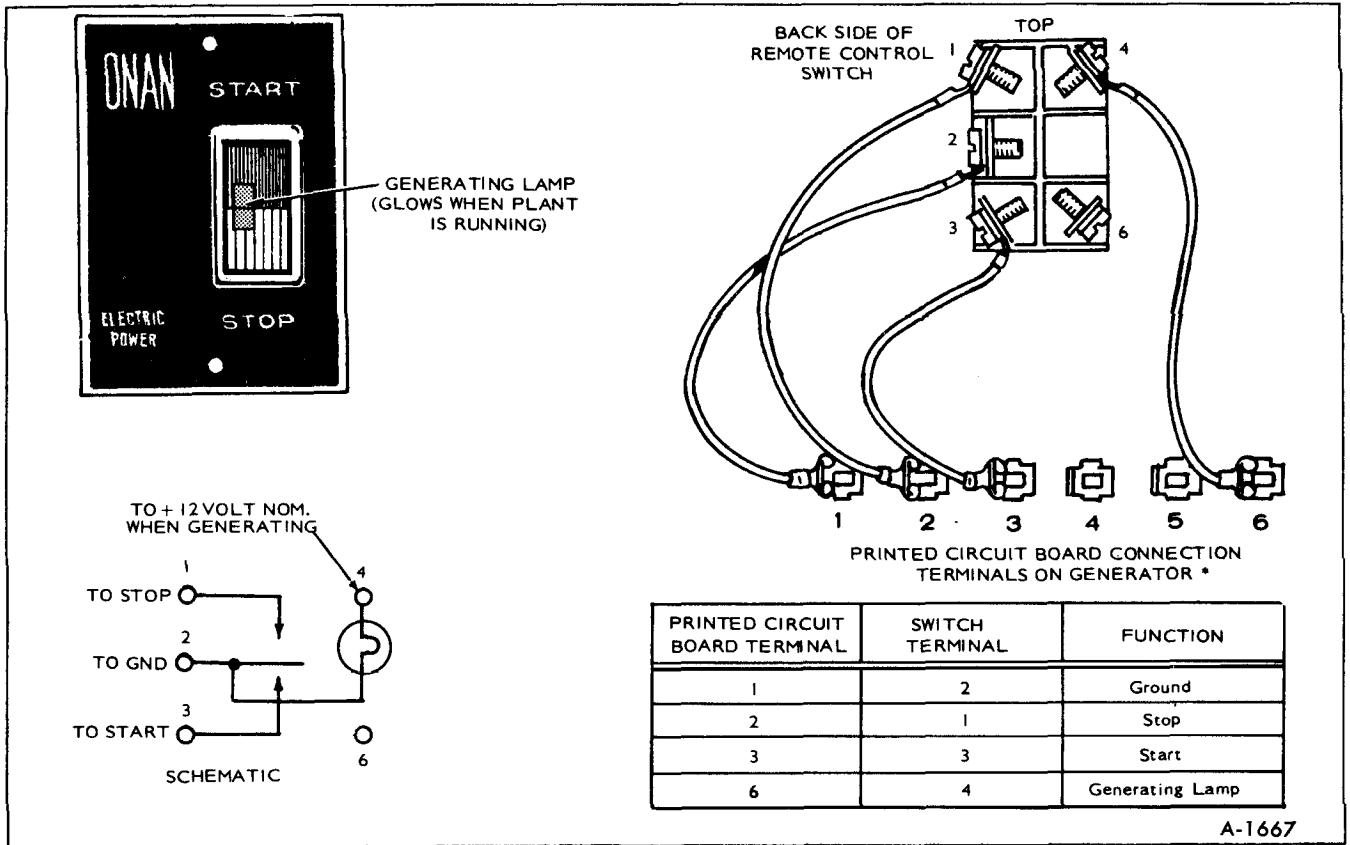
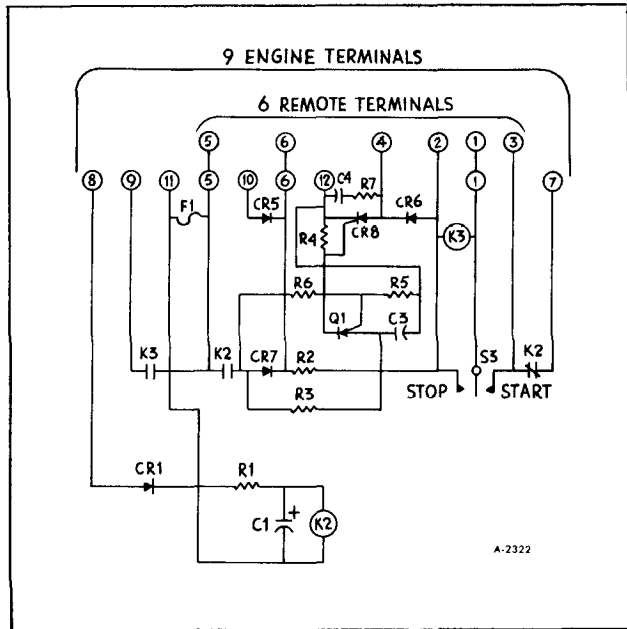

Figure 80-Control System Schematic



A-1667

Figure 81-Remote Control Switch



A-2322

Figure 82-Control Panel Wiring

### EMERGENCY START-STOP OPERATION

In an emergency situation the control board, either normal or defective, can be bypassed to start or stop the unit. To completely bypass all control board functions connect a jumper from terminals 9 to 11. This energizes the ignition and fuel pump. Then temporarily jumper terminals 1 and 7 to energize starter. Remove this jumper as soon as the engine starts and runs. **DO NOT** reconnect this jumper while the engine is running. To stop, remove the jumper from terminals 9 and 11.

**CAUTION:** This emergency operation **DOES NOT** provide fuse protection, start disconnect or low oil pressure shutdown and should not be used without monitoring the motor generator.

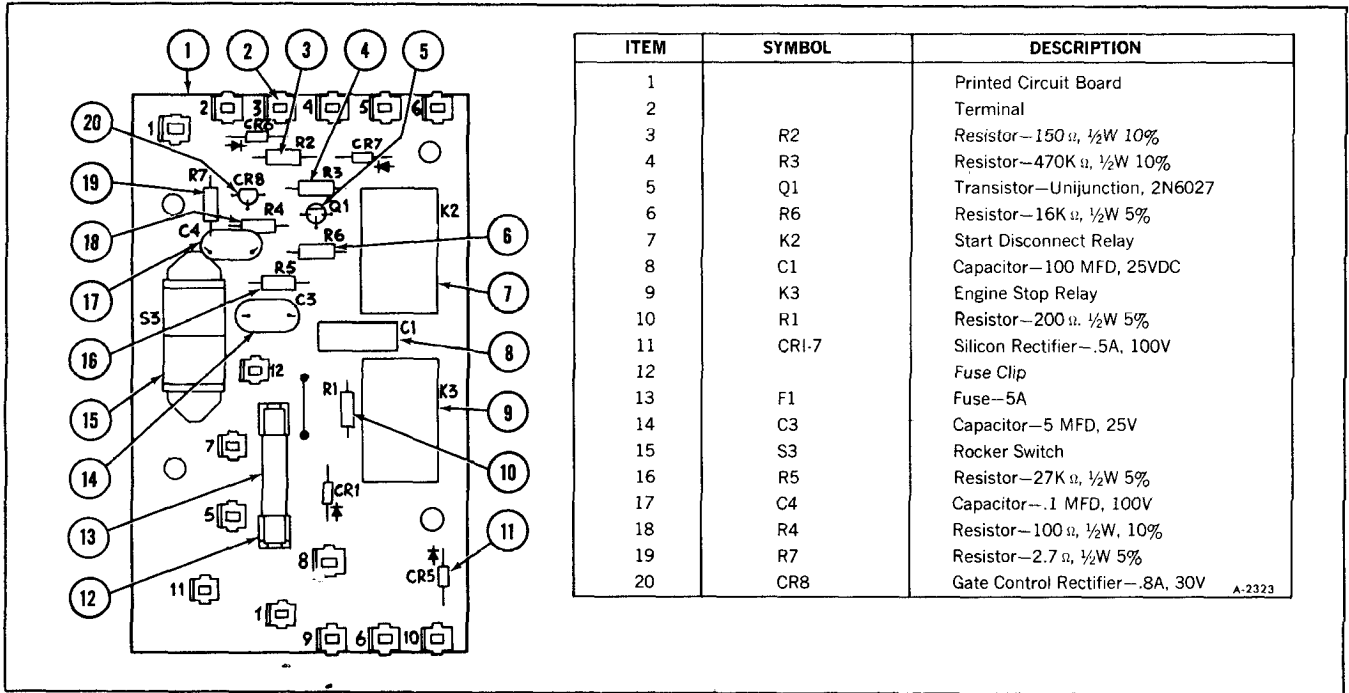

Figure 83—Control Panel

# SPECIFICATIONS

## 4KW MODEL

### ENGINE

- Engine Manufacturer..... Onan
- Engine Design ..... Four Cycle, Air Cooled, L Head
- Fuel Used..... Gasoline (Regular Grade)
- Number of Cylinders..... Two
- Bore ..... 3-1/8 inch
- Stroke ..... 2-5/8 inch
- Oil Capacity ..... 3 quarts
- (With Filger Change)..... 3-1/2 quarts
- Battery Voltage ..... 12 volt
- Starting System ..... Solenoid Shift
- Battery Charging System..... 10 amp Flywheel Alternator

### GENERATOR

- 60 Hertz Recreational Vehicle Rating ..... 4KW (4000 watts)
- Voltage ..... 120
- Current Rating (Amperes) ..... 33
- Phase ..... Single
- Wire ..... Two

### TUNE-UP SPECIFICATIONS

- Spark Plug Gap ..... .020"
- Breaker Point Gap (Full Separation - Engine Cold) ..... .025"
- Ignition Timing (Engine Not Running - Cold Setting) ..... 26° BTC
- Ignition Timing (Engine Running - Hot) ..... 21° BTC
- Tappet Adjustment (Engine Cold)
  - Intake ..... .003"
  - Exhaust..... .010"

**STARTER**

Engaging System .....Solenoid-operated Overrunning Clutch  
 Nominal Output.....0.68 Hp  
 Rated Voltage ..... D.C. 12 V.  
 Field Connection ..... Compound  
 Direction of Rotation ..... Counterclockwise (Viewing from pinion end)  
 Weight .....6.76 lbs.

**6KW MODEL**

**ENGINE**

Manufacturer ..... Onan  
 Design..... Four Cycle, Air Cooled, L Head  
 Fuel ..... Gasoline, Regular Grade  
 Fuel Pump ..... 12V, Electric  
 Cylinders ..... Two  
 Bore ..... 3-9/16 inch  
 Stroke ..... 3 inch  
 Oil Capacity .....4 quarts  
 (With Filter Change) ..... 4-1/2 quarts  
 Battery Voltage ..... 12 Volt  
 Battery Charging System..... 10 Ampere, Flywheel Alternator  
 Starting System ..... Solenoid Shift

**GENERATOR**

Manufacturer ..... Onan  
 Design..... Revolving Armature, Four Pole, 1800 rpm  
 60 Hertz Recreational Vehicle Rating .....6000 Watts (6KW)  
 Voltage ..... 120 Volts  
 Current Rating..... 50 Amperes  
 Phase ..... Single  
 Wire ..... Two

**TUNE-UP SPECIFICATIONS**

Spark Plug Gap ..... .020 inch  
 Breaker Point Gap (Full Separation) ..... .020 inch  
 Ignition Timing (Engine Running or Static) ..... 25° BTC  
 Tappet Adjustment (Engine Cold)  
     Intake ..... .003 inch  
     Exhaust..... .012 inch

**STARTER**

Engaging System .....Solenoid-operated Overrunning Clutch  
 Nominal Output..... 1.0 HP  
 Rated Voltage ..... D.C. 12 V.  
 Field Connection ..... Series  
 Direction of Rotation ..... Counterclockwise (Viewing from pinion end)  
 Weight ..... 3.7 lbs.

**DIMENSIONS AND CLEARANCES**

ALL DIMENSIONS & CLEARANCES GIVEN IN INCHES UNLESS OTHERWISE SPECIFIED.

Readings taken at 70° F.

**4KW MODEL**

		INCHES	
<b>CYLINDER AND PISTON</b>			
Piston to Pin (70°) .....	.0001	-	.0005
Pin to Connecting Rod			
Clearances .....	.0002	-	.0007
Piston Ring Gap in Cylinder .....	.010	-	.020

Piston Clearance in Cylinder Solid Type-Measured .10 Below Oil Controlling Ring – 90° From Pin .....	.003	–	.005
Cylinder Bore-Honed Std. ....	3.1265	–	3.1275
<b>CRANKSHAFT AND CAMSHAFT</b>			
Crankshaft Main Bearing Journal to Bearing Clearance Steel Backed Aluminum .....	.0025	–	.0038
Crankshaft End Play .....	.006	–	.012
Camshaft End Play.....		.003"	
Crankshaft Rod Journal to Rod Bearing Clearance. Aluminum Rod .....	.0020	–	.0033
Connecting Rod End Play .....	.002	–	.016
Timing Gear Backlash.....	.002	–	.003
Oil Pump Gear Backlash .....		.002"	
<b>TAPPET AND VALVES</b>			
Tappet to Cylinder Block Clearance .....	.0015	–	.0030
Valve Seat Width.....	1/32	–	1/8
Valve Stem to Guide – Intake.....	.0010	–	.0025
Valve Stem to Guide – Exhaust .....		.0025	
Valve Face Angle .....		45°	
Valve Seat Angle .....		45°	
Valve Tappet Clearance – Intake 70° F .....		.003"	
Valve Tappet Clearance – Exhaust 70° F.....		.010"	

**6KW MODEL**

Valve Tappet Clearance Intake .....		0.003"	
Exhaust .....		0.012"	
Valve Stem in Guide – Intake.....	0.001"	–	0.0025"
Valve Stem in Guide – Exhaust .....	0.0025"	–	0.004"
Valve Spring Length Free Length .....		1.662"	
Compressed Length .....		1.375"	
Valve Spring Tension (lb) Open .....	71	–	79
Closed .....	38	–	42
Valve Seat Bore Diameter Intake .....	1.5645"	–	1.5655"
Exhaust .....	1.2510"	–	1.2520"
Valve Seat Diameter Intake .....	1.569"	–	1.570"
Exhaust .....	1.255"	–	1.256"
Valve Stem Diameter Intake .....	0.3425"	–	0.3430"
Exhaust .....	0.3410"	–	0.3415"
Valve Guide Diameter (I.D.).....	0.344"	–	0.346"
Valve Lifter Diameter .....	0.7475"	–	0.7480"
Valve Lifter Bore .....	0.7500"	–	0.7515"
Valve Seat Interference Width.....	1/32"	–	3/64"
Valve Face Angle.....		44°	
Valve Seat Angle .....		45°	

Valve Interference Angle .....		1°	
Crankshaft Main Bearing .....	0.0025"	-	0.0038"
Crankshaft End Play .....	0.005"	-	0.009"
Camshaft Bearing .....	0.0015"	-	0.003"
Camshaft End Play .....		.003"	
Camshaft Lift.....		.300"	
Camshaft Bearing Diameter .....	1.3760"	-	1.3770"
Camshaft Journal Diameter .....	1.3740"	-	1.3745"
Rod Bearing (Forged Rod).....	0.0005"	-	0.0023"
Connecting Rod End Play (Ductile Iron) .....	0.002"	-	0.016"
Timing Gear Backlash .....	0.002"	-	0.003"
Oil Pump Gear Backlash .....	0.002"	-	0.005"
Piston to Cylinder, Strut Type (Measured below oil-control- ling ring - 90° from pin Clearance .....	0.0015"	-	0.0035"
Piston Pin Diameter .....	0.7500"	-	0.7502"
Piston Pin in Piston.....		Thumb Push Fit	
Piston Pin in Rod .....	0.0001"	-	0.0005"
Piston Ring Groove Width			
Top 1.....	0.0955"	-	0.0965"
Top 2.....	0.0955"	-	0.0965"
Top 3.....	0.1880"	-	0.1890"
Crankshaft Main Bearing			
Journal - Standard Size.....	1.9992"	-	2.000"
Main Bearing Diameter .....	2.0015"	-	2.0040"
Main Bearing Clearance .....	0.0015"	-	0.0043"
Crankshaft Rod Bearing			
Journal - Standard Size.....	1.6252"	-	1.6260"
Cylinder Bore - Standard Size.....	3.5625"	-	3.5635"

## TORQUE SPECIFICATIONS

<b>4KW MODEL</b>	<b>FT.-LBS.</b>
Connecting Rod Bolt - Aluminum Rod .....	14-16
Flywheel Mounting Screw.....	35-40
Oil Pump .....	7-9
Gearcase Cover .....	8-10
Rear Bearing Plate .....	25-27
Oil Base Mounting Screws .....	18-23
Cylinder Head Nuts .....	14-16
Manifolds - Intake and Exhaust .....	8-10
Starter Mounting Bolts .....	18-20
Generator Through - Studs .....	15-18
Armature Hold-down Nut (12-Point) .....	45-50
Spark Plugs .....	15-20
<b>6KW MODEL</b>	<b>FT.-LBS.</b>
Connecting Rod Bolts .....	27-29
Flywheel Mounting Screw.....	35-40
Oil Pump .....	7-9
Gearcase Cover .....	8-10
Rear Bearing Plate .....	19-21
Oil Base Mounting Screws .....	18-23
Cylinder Head Nuts .....	17-19
Intake Manifold.....	18-20
Exhaust Manifold .....	10-12
Oil Pan Screws (18).....	8-12



Starter Mounting Bolts .....	18-20
Generator Through-Studs .....	15-18
Armature Hold-Down Nut (12 Point) .....	45-50
Spark Plugs .....	15-20
<b>GENERATOR (4KW and 6KW)</b>	<b>FT.-LBS.</b>
Generator Through Studs (4) .....	15-18
Armature Hold Down Nut-12 Point .....	45-50
Compounding Reactor Studs .....	4-6
Brush Block Assembly Studs .....	4-6

# KOHLER MOTOR GENERATOR

Contents of this sub-section are listed below:

SUBJECT	PAGE NO.
General Information .....	24C-52
Motor Generator Trouble Diagnosis .....	24C-53
Motor Generator Replacement .....	24C-54
Engine Repair .....	24C-55
Engine Overhaul .....	24C-64
On Vehicle Adjustment and Servicing .....	24C-65
Specifications .....	24C-73

## GENERAL INFORMATION

The 4,000 watt Kohler motor generator (figure 1) is powered by a single, horizontally mounted, cylinder gasoline engine. The generator has a built-in exciter which functions as a starter motor to crank the

engine during starting then switches to its generating function after the engine starts. The exciter functions as a battery charger while the engine is operating.

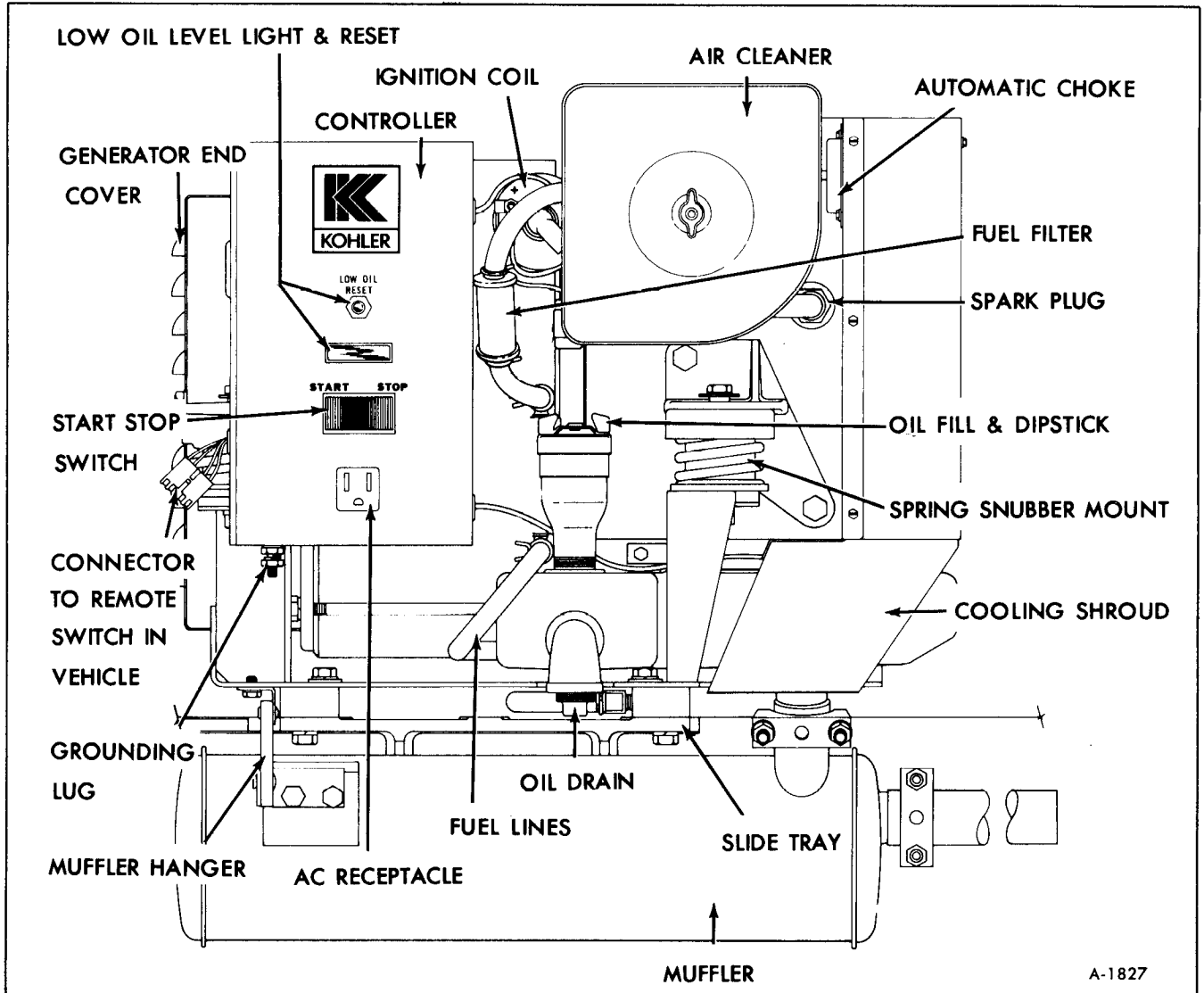

Figure 1-4KW Kohler Motor Generator

Lubrication is provided by a splash type oil system. a low oil sensor is built into the unit to protect the engine.

The motor generator does not have a separate fuel supply. Fuel is drawn from the vehicle's main fuel tank. An electric fuel pump is used to supply the unit with gasoline.

# MOTOR GENERATOR TROUBLE DIAGNOSIS

## ENGINE DIAGNOSIS

When troubles occur, don't overlook simple causes which might seem too obvious to be considered. A starting problem could, for example, be attributed simply to an empty fuel tank. The chart below lists some common causes of engine troubles – use this as a guide to locate causing factors.

PROBLEM	FUEL RELATED CAUSES			IGNITION CAUSES			OTHER CAUSES					
	NO FUEL	IMPROPER FUEL	FUEL MIX. WRONG	NO SPARK	POOR IGNITION	IMPROPER COOLING	IMPROPER LUBRICATION	POOR COMPRESSION	VALVE PROBLEMS	CARBON BUILD-UP	GOVERNOR FAULTY	ENGINE OVERLOADED
WILL NOT START	X			X				X	X			
HARD STARTING		X	X		X	X		X	X			
STOPS SUDDENLY	X			X			X		X			
LACKS POWER		X	X		X	X		X	X	X		X
OPERATES ERRATICALLY		X	X		X						X	
KNOCKS OR PINGS		X	X			X				X		X
"SKIPS" OR MISFIRES			X		X							
BACKFIRES			X		X				X			
OVERHEATS			X		X	X			X			X

Kohler Motor Generator Diagnosis

## GENERATOR DIAGNOSIS

Problem	Possible Cause
No output.	<p><b>LOOSE TERMINAL CONNECTIONS:</b> Check for loose or bad connections.</p> <p><b>BRUSHES NOT SEATED:</b> Check for loose springs or brushes sticking in holder.</p> <p><b>DIRTY COMMUTATOR:</b> Poor contact caused by build up of dirt or oily film on commutator.</p> <p><b>SHORT IN AC CIRCUIT:</b> If engine labors while running, check for short circuit in AC line. If a short develops in the AC armature, the armature will get very hot.</p> <p><b>BATTERY CONNECTIONS REVERSED (MUST BE NEGATIVE GROUND)</b></p>

Problem	Possible Cause
Low output or excessive drop in voltage.	<p><b>ENGINE SPEED TOO LOW:</b> Check with tachometer. Readjust governor speed.</p> <p><b>OVERLOAD:</b> Make sure plant capacity is not being exceeded.</p> <p><b>ENGINE IN POOR CONDITION:</b> Poor compression, excessive carbon, faulty ignition, wrong polarity or any other condition causing poor performance may show up in reduced output.</p> <p><b>CYCLIC COMPENSATOR DEFECTIVE BRUSHES WORN EXCESSIVELY</b></p>
	<p><b>BRUSHES STICKING:</b> If brushes are wrong size, they may stick in holder and chatter.</p> <p><b>BRUSH TENSION WRONG:</b> If spring tension is wrong, brushes may chatter.</p> <p><b>WRONG BRUSHES:</b> Brush grade and material must be correct – use only specified brushes.</p>

## CYCLIC COMPENSATOR DIAGNOSIS

Some problems that could be attributed to defects in the Cyclic Compensator circuit are described in the following.

1. *No AC output.* If the battery cables are reversed, no output can be obtained because the diode acts to block the shunt field circuit. The battery must have a negative ground. Failure of the diode in the open mode could also be the cause of no output.

2. *Abnormal AC output voltage.* Variations in voltage could be caused by loose connections in the circuit – if this condition is found, the Cyclic Compensator could be damaged as a result. Higher than normal voltage may be an indication that the compensator is continuously shorting out the field resistor. Lower than normal voltage may indicate that the compensator is not triggering.

3. *Test to establish cause.* Since the symptoms described in foregoing may be due to causes other

than a faulty Cyclic Compensator, make the following test to determine if the compensator is actually at fault.

**STEP A:** Operate the generator set and record the output voltages.

**STEP B:** Stop the set then disconnect the red lead at the field resistor. **CAUTION:** Severe arcing will occur if the set is running when this lead is disconnected.

**STEP C:** Restart the set and compare output voltage to that obtained in Step A. If voltage was high and decreases with red lead disconnected, the Cyclic Compensator has failed “shorted”. If voltage was low and disconnecting the red lead has no effect, the compensator has failed “open” or the connections to it are not proper. Shorting the resistor should cause the voltage to go higher than normal.

## MOTOR GENERATOR REPLACEMENT

### REMOVAL

1. Disconnect the fuel inlet line at the fitting on the bottom of the mounting skid.

2. Disconnect battery leads from solenoid inside the controller then unplug the switch leads from the

connector at the side of the controller box. The set is grounded to the vehicle frame, disconnect this lead from the connector on the upper corner of the generator frame. Disconnect load leads from terminals L1, L2 and L3 inside controller.

3. Remove the muffler from the bottom of the mounting skid.

4. Remove the four capscrews which secure the mounting skid to the support rails then slide the set out of vehicle.

5. Disconnect the fuel line running from the skid to the fuel pump at the fitting on the pump, remove the mounting screw from each of the four rubber mounts then lift the engine-generator off the mounting skid (figure 2).

## INSTALLATION

1. Position motor generator on mounting skid and install mounting screw at each of the four rubber mounts. Connect fuel line to fuel pump.

2. Position motor generator and mounting skid assembly on support rails and secure with four cap screws.

3. Install muffler to bottom of mounting skid.

4. Connect load leads to terminals L1, L2 and L3 inside controller. Connect ground lead to upper corner of generator frame. Connect switch leads at con-

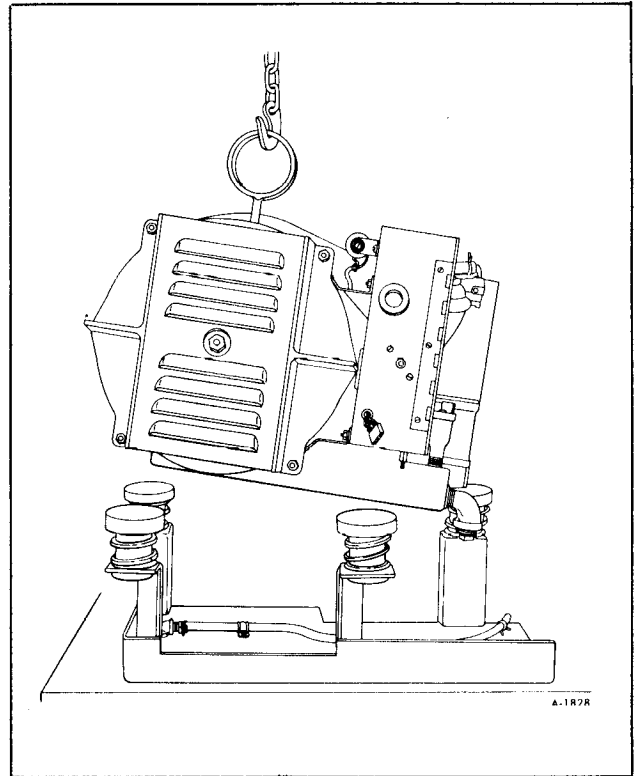

Figure 2—Separating Generator Set from Mounting Skid

necter at side of controller box. Connect battery leads to solenoid inside controller.

5. Connect fuel inlet line at fitting on bottom of mounting skid.

## ENGINE REPAIR

The generator set must be completely removed from the vehicle to make the repairs described in this section. The motor generator must also be separated from the mounting skid – the threaded hole at the top of the generator frame is for a lifting eye.

### SEPARATING GENERATOR FROM ENGINE

After removing the mounting skid, place blocks under the motor generator so that the weight of the unit rests on the oil pan of the engine then remove the generator using the following procedure.

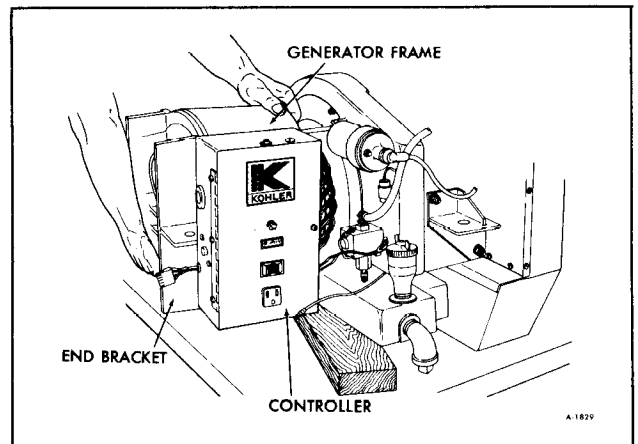

Figure 3—Removing End Bracket

1. Disconnect leads at terminal 5 in the controller – these go to ignition coil and electric fuel pump.

2. Remove generator end cover, lift AC and DC brushes then remove the four nuts which secure the end bracket assembly to the frame of the generator. Use puller to separate the end bracket from the ball bearing (figure 3).

3. The end bracket and generator frame (with controller attached) can now be slipped over the end of the armature and removed.

4. Remove the air baffle from the fan housing, (figure 4) turn the thru bolt out about 2-3 turns then bump the end of the thru bolt (with soft head hammer) until the armature separates from the taper on the engine crankshat (figure 5). Do not separate the rotor and adapter from the armature unless it is necessary to replace either of these items.

5. To avoid bending the studs or resulting breakage of the fan housing at the stud bosses, remove the 4 long studs from the housing – this completes the procedure for removing the generator from the engine.

## ROTOR ADAPTER

The generator must be disassembled to replace the rotor adapter or rotor. The adapter and rotor are secured as a unit to the generator armature. If rotor replacement is needed, it is not necessary to separate the adapter from the armature. If replacing the adapter, make sure the roll pin is used to locate the replacement adapter – this is for balancing the rotor adapter.

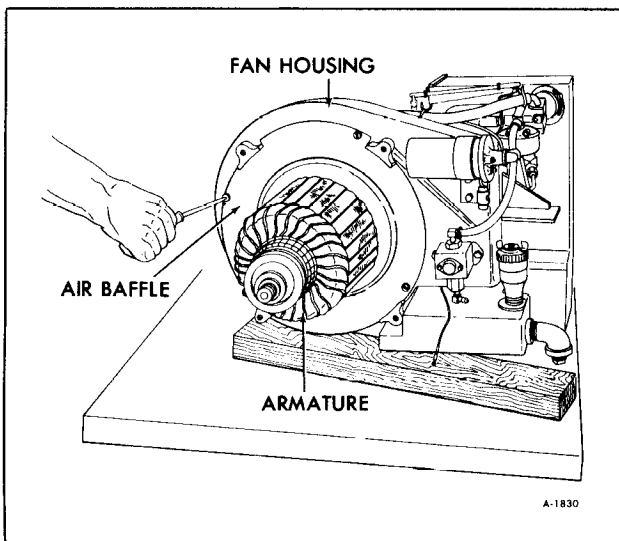

Figure 4–Removing Air Baffle From Fan Housing

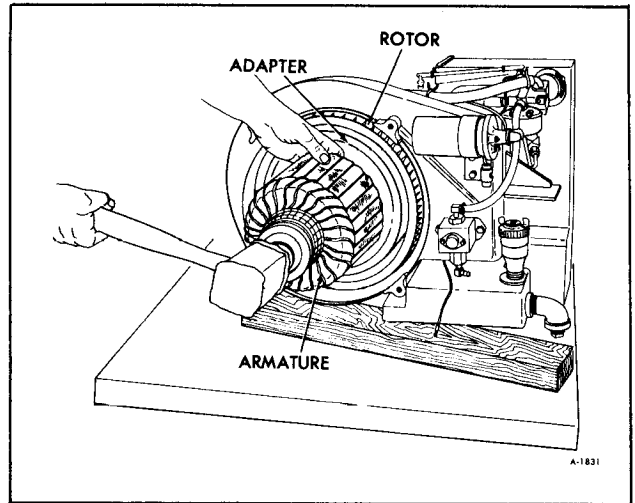

Figure 5–Separating Armature From Crankshaft

## BALL BEARING

The generator must be separated from the engine and the crankshaft removed from the engine to replace either of the ball bearings. After removing the fan housing and closure plate, disconnect the connecting rod then press the crankshaft out of the crankcase. The ball bearings are press fitted on the crankshaft – use an arbor press to remove the faulty bearing and also to press the replacement bearing on the shaft. Crankshaft end play must be checked after reinstallation (refer to crankshaft procedure) and new oil seals should also be installed.

## CAMSHAFT

To repair or replace the ACR actuating spring on the cam gear, remove the gear cover at top of engine and turn the crankshaft until the ACR mechanism appears. To replace the camshaft; removal of the generator, fan housing, closure plate and crankshaft is required. The camshaft is hollow and rides on a pin pressed into both sides of the crankcase. Press the pin out thru the fan housing side of the crankcase then remove the camshaft. When installing replacement camshaft, use .005 and .010" spacers as required to establish .005-.010" end play – refer to Figure 6 for end play. The pin must be pressed in from the fan housing side of the crankcase due to tapered bore on the opposite end of the crankcase (figure 7).

## CRANKCASE

The generator must be removed and the engine completely disassembled to facilitate replacement or reboring of the crankcase. If the engine is damaged

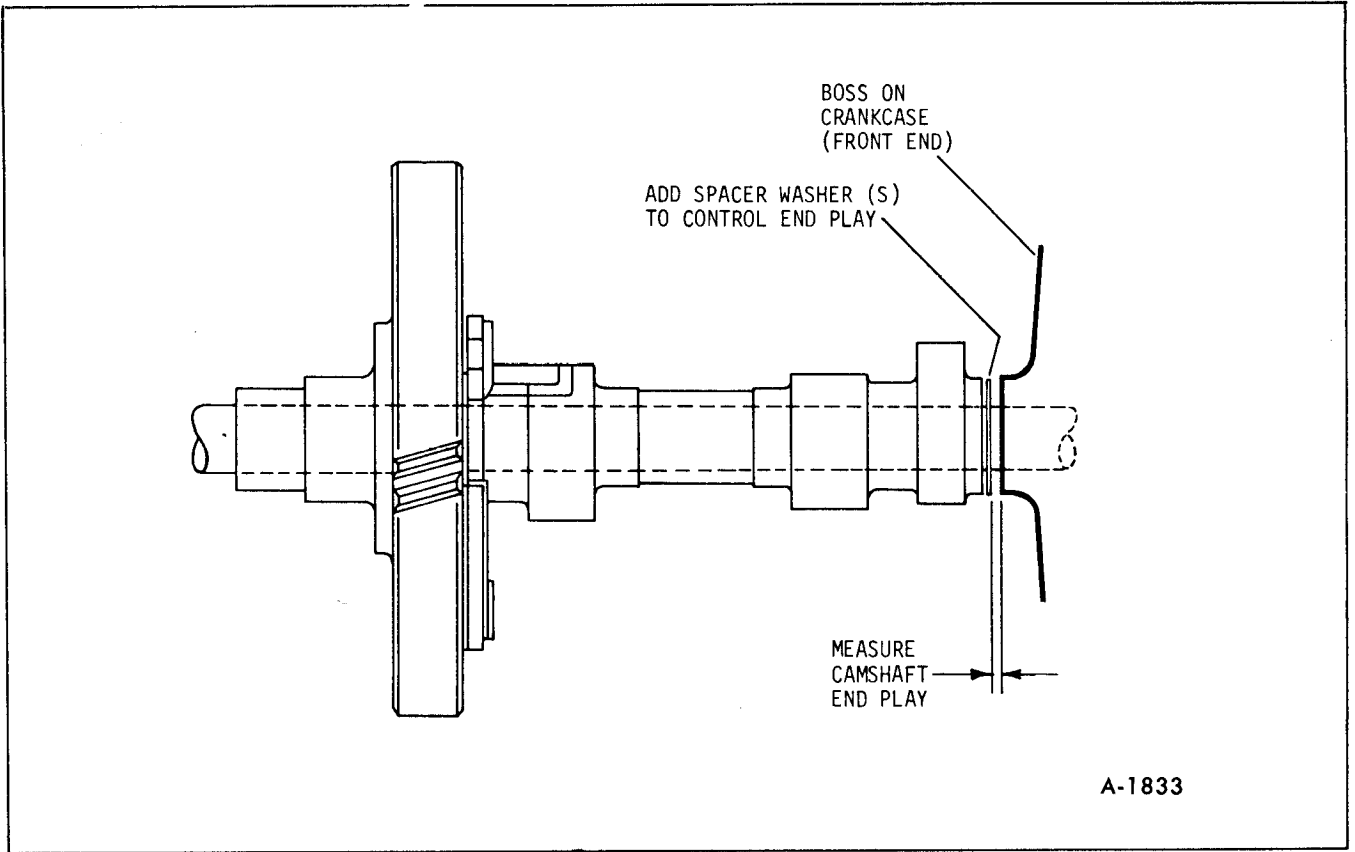

Figure 6-Camshaft Endplay Adjustment

extensively, a new short block assembly should be used. The short block includes crankcase with all internal parts such as crankcase, camshaft, piston-rod, valves plus fan housing installed. All other items are either transferred from the failed engine or taken from stock to build the short block up to a complete engine. If reboring is needed, rebore cylinder .010, .020 or .030" oversize and use the corresponding

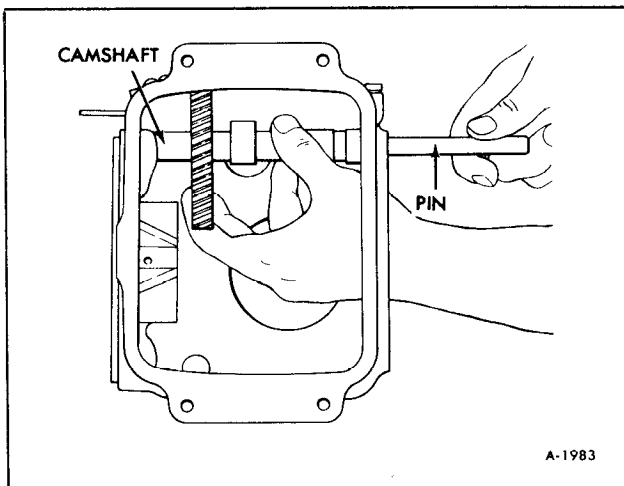

Figure 7-Installing Camshaft Pin

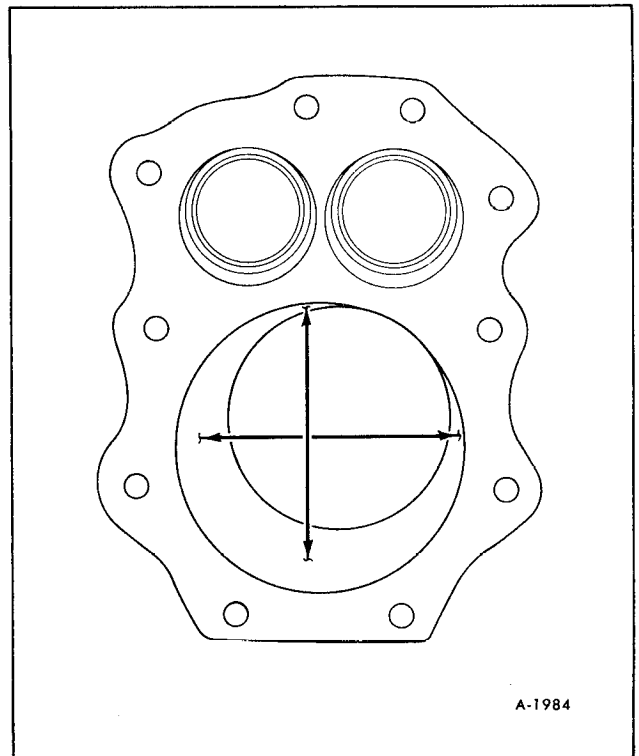

Figure 8-Measuring Cylinder Bore For Out of Round

oversize piston-ring assembly. New diameter of the cylinder is 3.750" – rebores to the nearest oversize when cylinder bore is worn to 3.753" or taper exceeds .0015" or the bore is out of round more than .005". These measurements are shown in Figure 8.

**CYLINDER REBORING PROCEDURE:** (figure 9) While most commercially available cylinder bores can be used with either portable drills or drill presses, the use of a low speed drill press is preferred as it facilitates more accurate alignment of the bore in relation to the crankshaft crossbore. Reboring is best accomplished at drill speed of about 600 RPM. After installing coarse stones in hone, proceed as follows.

1. Lower hone into bore and after centering, adjust so that stones are in contact with walls. Diesel fuel oil or kerosene can be applied to the stones as a cutting-cooling agent.

2. With the lower edge of each stone positioned even with the lowest edge of the bore, start drill and honing process. Move hone up and down while reboring to prevent formation of cutting ridges. Check size frequently.

3. When bore is within .0025 of desired size, remove coarse stones and replace with burnishing stones. Continue with burnishing stones until within .0005 of desired size then use finish stones and polish to final size.

4. After reboring, carefully clean cylinder wall with soap and water, then after drying thoroughly, apply light coat of SAE 10 oil to prevent rust.

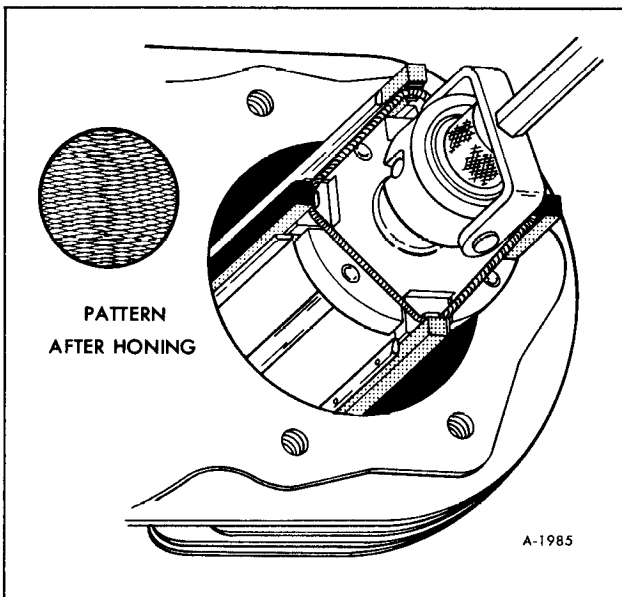

Figure 9–Reboring Cylinder with Hone

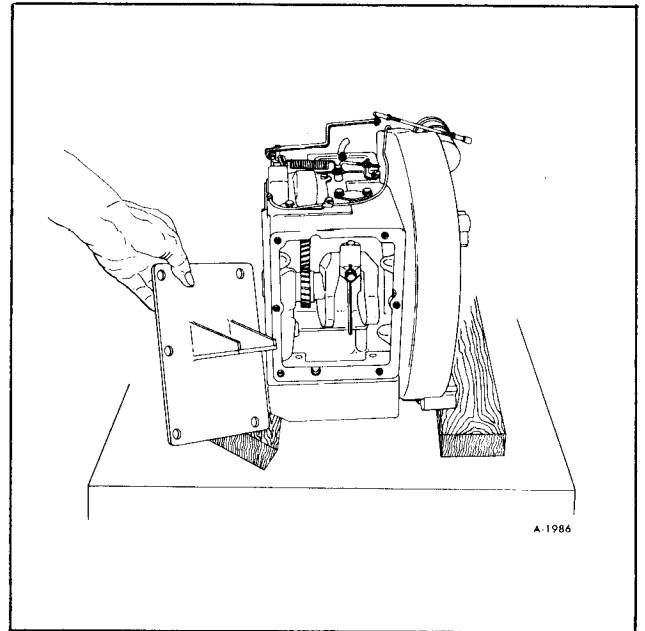

Figure 10–Removing Closure Plate

## CRANKSHAFT

The generator, closure plate and fan housing must be removed before the crankshaft can be removed (figure 10). New diameter of the crankpin is 1.500 – regrind crankpin or replace crankshaft if the crankpin out of round exceeds .0005 or if the taper exceeds .001". If keyway or gear teeth are worn or chipped, replace the crankshaft. Slight scoring of the crankpin can be cleaned with crocus cloth soaked in oil. If crankpin limits stated above are exceeded, replace crankshaft or regrind crankpin to use the .010" undersize connecting rod. Crankshaft end play

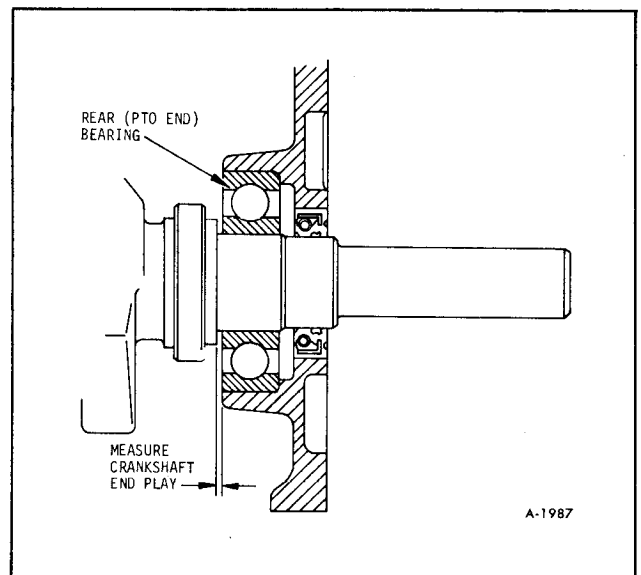

Figure 11–Crankshaft Endplay Adjustment



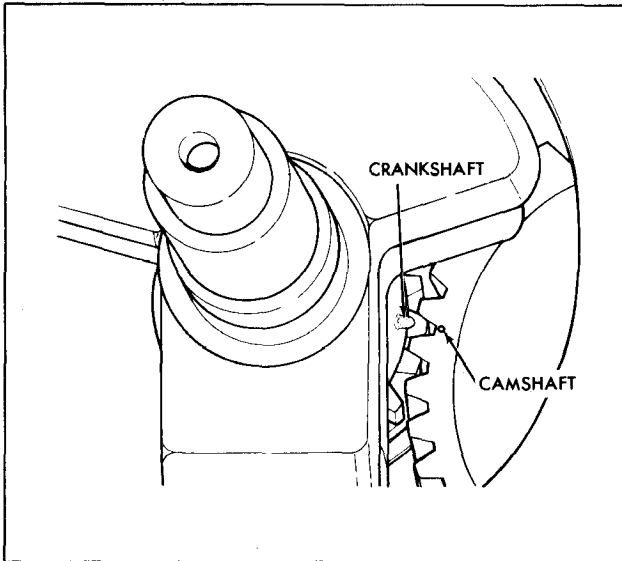

Figure 12—Timing Marks on Crankshaft and Camshaft

is established by installation of .010 and .020" fan housing gaskets as required to obtain correct end play of .002-.030" – refer to Figure 11 for details. Install thick gasket next to crankcase. When installing crankshaft, the timing marks on crankshaft and camshaft must be aligned as shown in Figure 12.

## GOVERNOR GEAR

The generator, fan housing, crankshaft and camshaft must be removed before the governor gear assembly can be replaced. Individual components of this assembly are non-serviceable – the assembly must be completely replaced if faulty. To replace, remove the welch plug, cross shaft bushing (see Figure 13) then pull the governor cross shaft out of the bushing so that it can be moved out of the way of the gear assembly. Press the gear assembly out of the crankcase, install new spacer washer, then replacement gear assembly. Reinstall cross shaft, welch plug, etc. The spacer washer eliminates the necessity for end play adjustment.

## VALVE GUIDE

To replace the valve guides, remove the valve cover, crankcase breather parts, cylinder head and valves then press guides into the valve chamber and carefully break protruding end until guide is completely removed. The guides should be replaced when the guide to valve stem clearance exceeds .0045". Install replacement guides to depth shown in Figure 21, then ream guide to .312-.313" I.D. with suitable valve guide reamer.

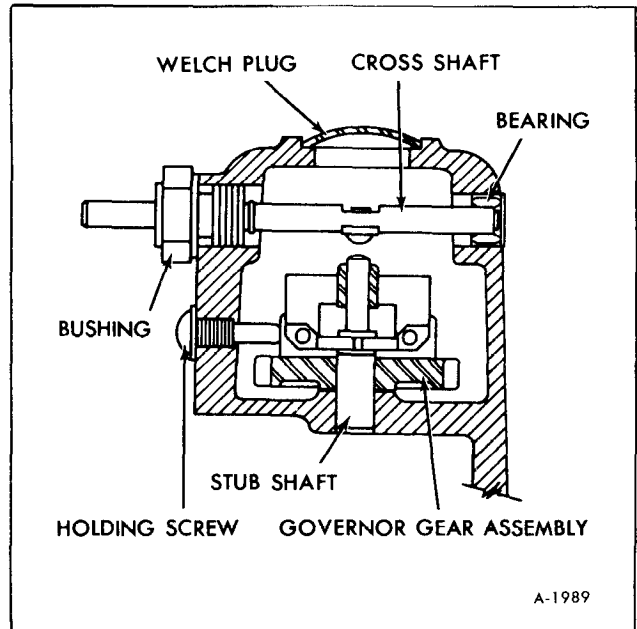

Figure 13—Cutaway View of Governor

## FAN HOUSING

Generator must be removed to replace the fan housing. The housing is secured to the engine crankcase with four countersunk screws. Detach the ignition coil, condenser and electric fuel pump from housing being replaced and install these on replacement housing after it is in position.

**NOTE:** Use same number of gaskets between housing and crankcase as this controls crankshaft end play.

## VALVE SEAT INSERT

Cylinder head and valves must be removed to inspect or recondition the valve seat inserts. Seating surfaces can usually be reconditioned – seating angle is 89° and width should be as close to 1/32" as possible. If width exceeds 1/16", recondition with 45° and 15° cutters. After recutting, valves must be tapped in to provide proper seat. Make sure valve clearance is readjusted after reconditioning the seat inserts.

## OIL PAN

To replace the oil pan or gasket, drain oil from pan, disconnect the engine and generator mounts, lift the engine-generator off the mounting skid then remove the four capscrews securing the pan to the crankcase then remove the oil pan. If the pan is to

be replaced, remove the oil level indicator mechanism and transfer to the replacement pan.

## CYLINDER HEAD

To remove the cylinder head, disconnect the engine and generator mounts, then lift the engine-generator off the mounting frame. After this is done, remove the front mount support, spark plug, carburetor (detach at adapter), side air duct then the cylinder head and gasket. Blocked cooling fins often cause localized "hot spots" which can result in "blown" cylinder head gaskets. If gasket fails in area surrounding one of the retaining capscrews, high temperature combustion bases can burn away portions of aluminum alloy head. If no evidence of this is found, head should be checked for flatness. A slightly warped head can be resurfaced by simply rubbing it on a piece of sandpaper positioned on a flat surface. Carefully clean carbon deposits from cylinder head if it is to be reused – use putty knife of similar blade to scrape deposits. Be careful not to nick or scratch aluminum, especially in gasket seat area. Always use new cylinder head gasket and tighten cylinder head bolts in the sequence specified (Refer to figure 14). Torque bolts to 25 foot-pounds.

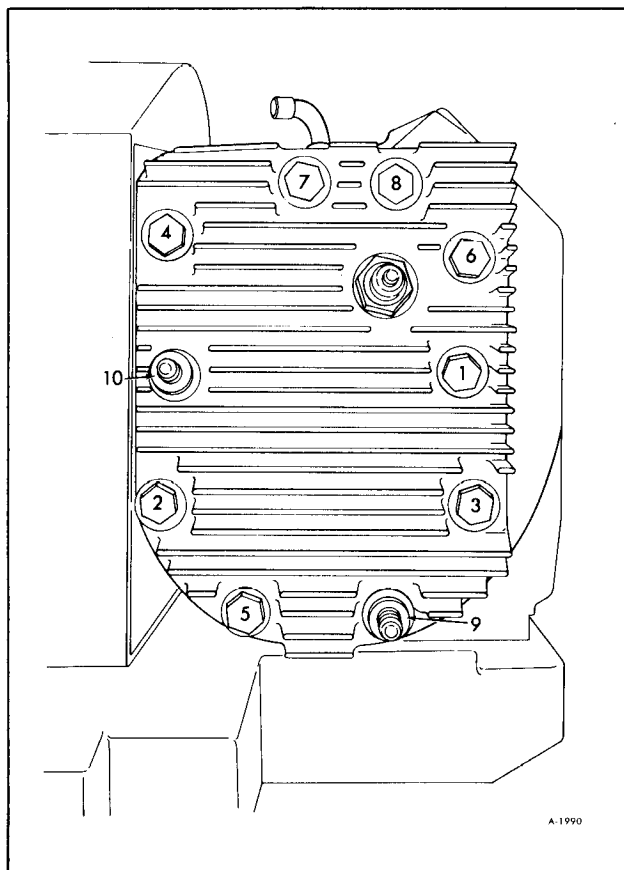

Figure 14—Cylinder Head Tightening Sequence

## PISTON AND PISTON RINGS

The piston-rod assembly can be removed without complete disassembly of the engine. To remove, disconnect motor generator from the skid, lift the motor generator off the skid then remove closure plate and cylinder head. Detach connecting rod from crankshaft then push piston-rod out thru head side of the cylinder. If a ridge has formed on outer edge of the cylinder, this will have to be removed with reamer before piston can be pushed out. Always install new piston rings – service rings are available in a standard set for use with original bore size and in .010", .020" and .030" oversize sets for rebored cylinders. Piston assemblies, including rings, pin and retaining rings, are also available in standard size and .010", .020" and .030" oversizes.

**DAMAGE ANALYSIS:** Scuffing and scoring of pistons and cylinder walls occurs when internal temperatures approach the melting point of the piston. Temperatures high enough to do this are created either by friction, which is usually attributed to improper lubrication, and/or overheating of the engine itself due to improper cooling. Ring failure is usually indicated by excessive oil consumption and blue exhaust smoke. When rings fail, oil is allowed to enter the combustion chamber where it is burned along with the fuel. High oil consumption can also occur when ring gap is incorrect – rings cannot properly conform to the cylinder walls under this condition. Oil control is also lost when ring gaps are not staggered during installation. When cylinder temperatures get too high, lacquer and varnish collect on pistons causing rings to stick which results in rapid wear of rings. A worn ring takes on a shiny or bright appearance. Scratches on rings and pistons are caused by abrasive material such as carbon or pieces of hard metal. Detonation damage occurs when a portion of the fuel charge ignites spontaneously from heat and pressure shortly after ignition. This creates two flame fronts which meet and explode to create extreme hammering pressures on a specific area of the piston. Detonation generally occurs from using fuels with too low octane rating. Pre-ignition or ignition of fuel charge before the timed spark can cause damage similar to detonation. Pre-ignition damage is often more severe than detonation damage – often, a hole is quickly burned right thru the piston dome by pre-ignition. Pre-ignition is caused by a hot spot in the combustion chamber such as glowing carbon deposits, blocked fins, improperly seated valves or wrong spark plug.

**INSTALLATION:** (figure 15 and 16) Before installing rings on piston, insert rings in cylinder bore to check for proper end gap. If cylinder bore is original size, ring end gap will be .010-.020" – if the bore is worn but within tolerances, end gap up to .030" is acceptable (figure 17). Replace piston if thrust face diameter is worn beyond 3.7425 – measure this just

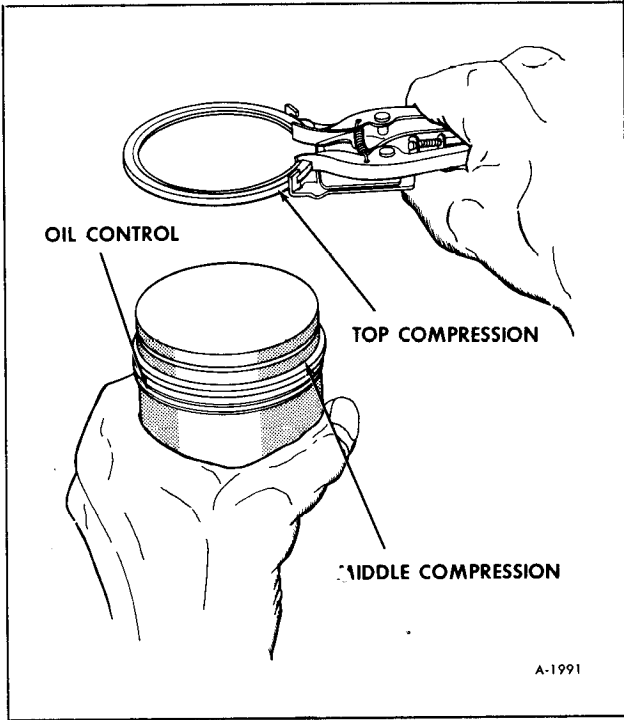

Figure 15—Installing Piston Rings

below the oil control ring groove and at right angles to the piston pin. Cylinder bore must be deglazed before using service ring sets.

## CONNECTING ROD

Inspection of the connecting rod can be accom-

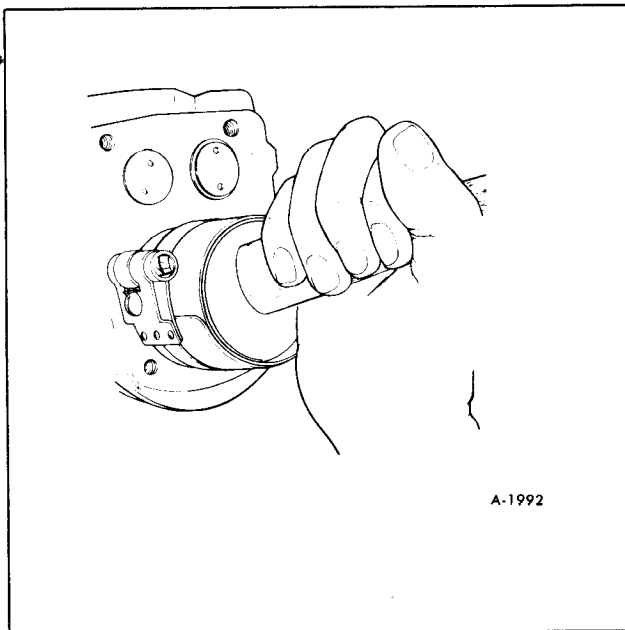

Figure 16—Using Ring Compressor To Install Piston

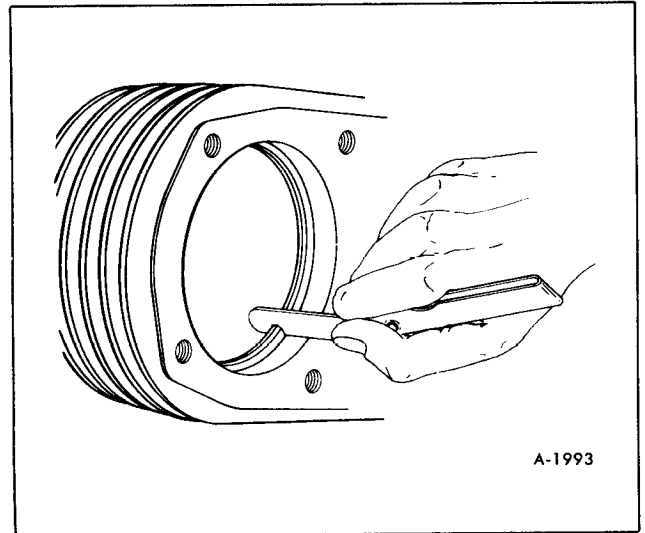

Figure 17—Measuring Piston Ring End Gap

plished after lifting the motor generator off the mounting skid and removing the closure plate.

**DAMAGE ANALYSIS:** Whenever a rod failure is encountered, look for telltale signs of heat discoloration in the big end area. Note that tin-plated connecting rods do not become black from overheating as do rods that are not plated – tin-plated rods will, however, discolor sufficiently to recognize overheating. Discoloration indicates overheating due to lack of proper lubrication. Improper lubrication re-

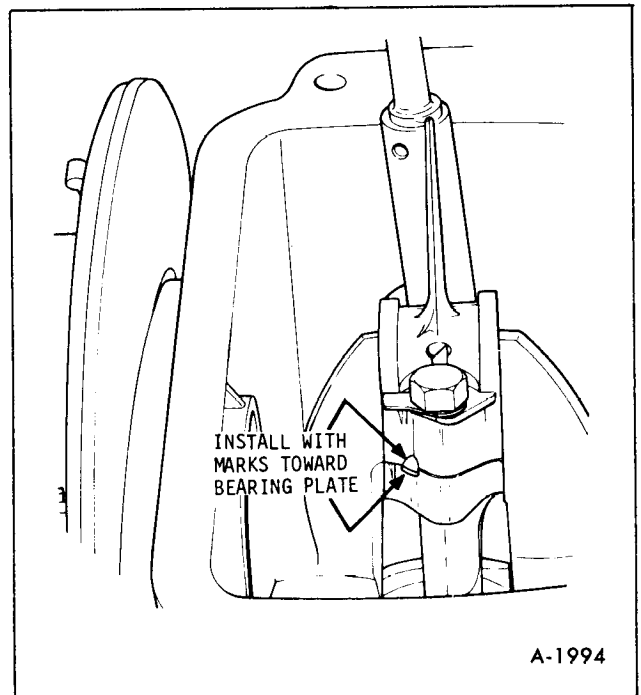

Figure 18—Match Marks on Connecting Rod and Cap

sults from using the wrong type of oil, operating with contaminated oil or oil that has broken down from extensive use. Running completely out of oil or operation with oil level below or above the safe range also contributes to rod failures. When such indicators are noted, stress the importance of using the right oil, keeping the level in the safe range, and changing oil at the specified intervals. Rod failures also occur from carelessness during installation. Apply liberal amounts of oil on crankpin, rod cap and capscrews and tighten rods to the torque values specified. When a rod literally pounds to pieces, the rod capscrews were probably undertightened.

**ROD REPLACEMENT:** (figure 18) The cylinder head and piston-rod assembly must be removed to replace the rod. Check big end (or crankpin end) for score marks, excessive running and/or side clearance. Replace rod if big end diameter exceeds 1.5025 or if rod to crankpin clearance exceeds .0035". Side clearance should be 1.180". Rods are available in .010" undersize for use with reground crankshaft.

## OIL SEAL

The seal on the outside of the crankcase can be replaced without any disassembly. The generator must be removed to gain access to the inner oil seal which is pressed into the fan housing.

**INSTALLATION:** Care must be used during installation to prevent the lip of the seal from rolling and creasing. Apply a liberal amount of light grease such as Lubriplate on the seal lip area. Use seal driver and seal sleeve of appropriate size. Press only against outer edge of seal when installing. Press squarely into position to the depth specified in Figure 19.

## OIL LEVEL INDICATOR SWITCH

The switch can be replaced or readjusted without

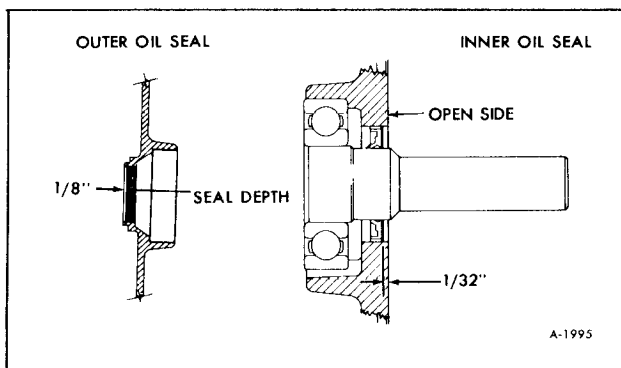

Figure 19—Oil Seal Installation Details

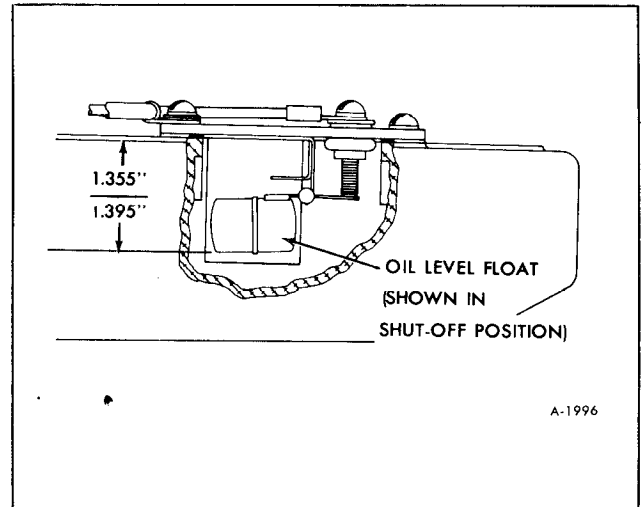

Figure 20—Oil Level Indicator Float Adjustment

any disassembly of engine or generator. Refer to Figure 20 for correct adjustment of float level. To replace or readjust the indicator switch, simply remove the cover on the outside edge of the oil pan. Make sure lead is connected to the correct post.

## VALVE MECHANISM (FIGURE 21)

Valve clearance can be checked without disassembly of generator or engine. To check or replace valves, valve springs, etc., the engine-generator must be lifted off the mounting skid and the cylinder head must be removed. Hard starting, loss of power accompanied by high fuel consumption could be symptoms of faulty valves although these symptoms could also be attributed to faulty rings – check the valves first.

**VALVE ANALYSIS:** After removal, clean valve head, face and stem with power wire brush then carefully inspect for defects such as warped head, excessive corrosion, worn stem end. If face and margin are in good shape and the margin is not less than 1/32", the valve could be reconditioned and reused. Corrosion on stem occurs from condensation due to improper preservation during storage or when engine is repeatedly stopped before it has a chance to reach normal operating temperatures. Replace corroded valves. An exhaust valve subject to overheating will have dark discoloration in area above valve guide – worn guides or faulty valve springs could cause this – also check for clogged air intake, blocked cooling fins, or too lean fuel mixture setting when this condition is found. Lead build-up on the inside of the intake valve head indicates the valve is leaking, allowing exhaust gases to enter the intake port. Gum deposits result from using stale fuel – fuel must be drained during the off season to prevent this condition.

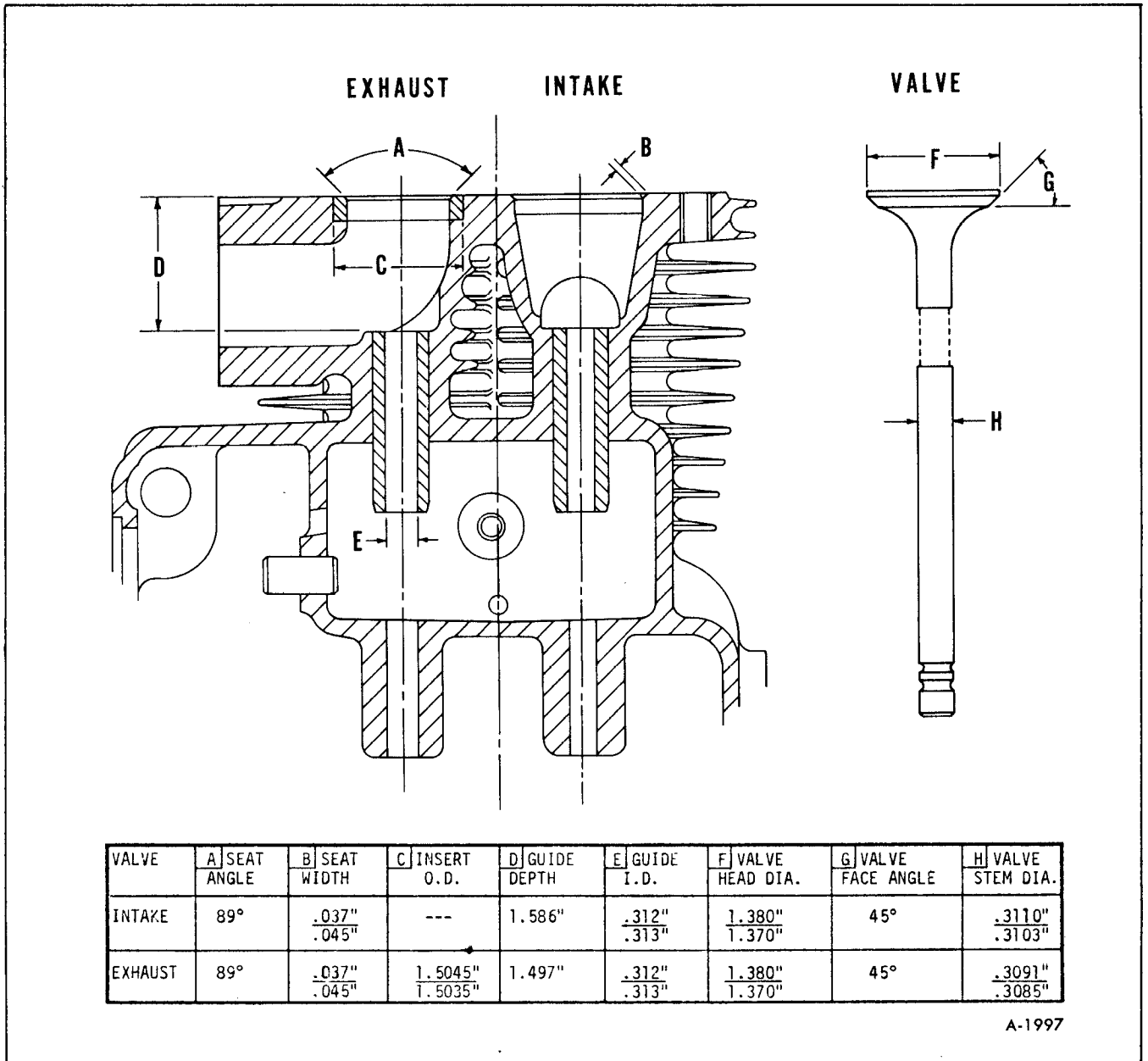

Figure 21-Valve Port Specifications

**REPLACEMENT:** After removing the cylinder head and breather components, compress the valve spring with valve compressor, remove keepers, rotor, spring and retainer then release the compressor and remove the valve. If seating surface is in good condition (refer to Insert-Valve Seat), insert replacement valve then lap in to provide proper seat. Use a valve grinder with suction cup and coat valve face with a "fine" grade of grinding compound. Continue rotating valve on seat until a smooth surface is obtained on seat and valve. Remove all traces of grind-

ing compound before reassembly of valve components. Readjust valve clearance before re-installing breather parts and cylinder head.

**VALVE ADJUSTMENT:** Turn crankshaft until both valves are closed. In this position, the cam has no effect on the tappets. Correct valve stem to tappet clearance (engine cold) is .008-.010" for the intake and .017-.020" for the exhaust valve. To adjust, turn the self-locking setscrew on tappet in or out until clearance is correct.

# ENGINE OVERHAUL

The following is the suggested sequence of disassembly to be used in the event the engine must be completely disassembled (See figure 22). Refer to "Engine Repair" for the reconditioning procedure for individual items or also for repairs requiring only partial disassembly. Reassembly is essentially the reverse of the sequence listed below.

- |                               |                                 |                              |
|-------------------------------|---------------------------------|------------------------------|
| 1. Air cleaner                | 8. Mounting bracket (cyl. head) | 15. Valve mechanism          |
| 2. Carburetor                 | 9. Air ducts, chute             | 16. Connecting rod cap       |
| 3. Carburetor adapter         | 10. Exhaust elbow; tubes        | 17. Piston – ring – assembly |
| 4. Ignition coil, condenser   | 11. Fan housing                 | 18. Crankshaft               |
| 5. Spark plug, breaker points | 12. Closure plate               | 19. Camshaft                 |
| 6. Fuel pump and lines        | 13. Cylinder head               | 20. Tappets                  |
| 7. Breather – valve cover     | 14. Oil pan                     | 21. Valve guides             |
|                               |                                 | 22. Seat inserts             |

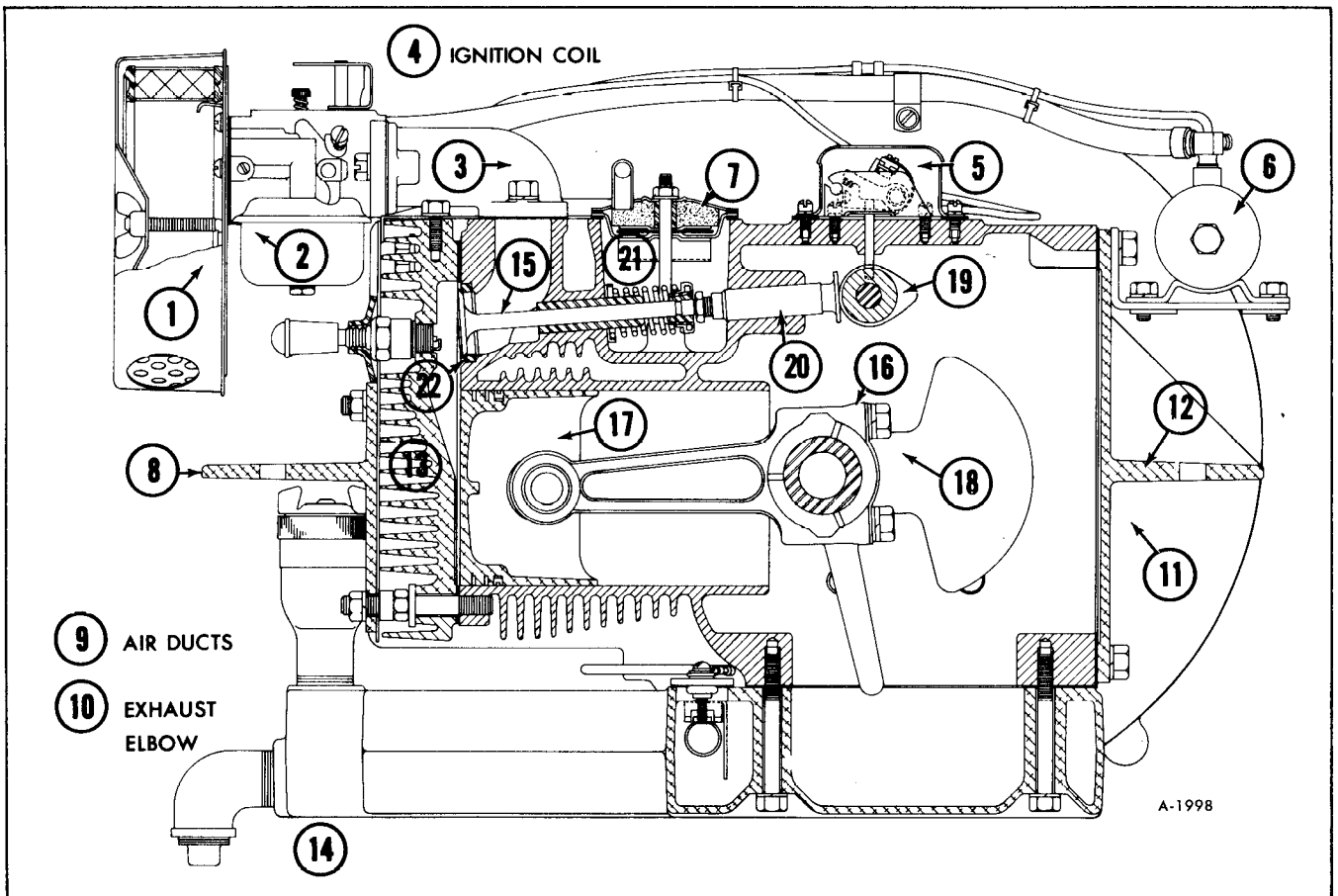

Figure 22–Cutaway View of Engine

# ON VEHICLE ADJUSTMENTS AND SERVICING

## AIR CLEANER (FIGURE 23)

This engine is equipped with dry element air cleaner. Under normal operating conditions, the element should be removed for cleaning every 50 hours or every 6 months, whichever occurs first. To clean, tap the element lightly against a flat surface – this will dislodge loose dirt from the element surface. Do not clean element in any liquid or clean with compressed air as this will ruin the filter material. Replace the element after 100 hours.

## COOLING SYSTEM

Cooling air is drawn into the fan housing by fan blades on the rotor which is attached to the armature of the generator. The air is then forced past the cooling fins on the cylinder block and head and into ductwork where it is expelled as heated air outside the vehicle. The rotor also draws cooling air in thru the louvers in the generator end bracket cover and circulates this air thru the generator internally. The exhaust outlet elbow and tube are located inside the ductwork to help keep the compartment cool. Keep all air inlet and outlets into the compartment and on the generator set clean and clear of obstruction at all times to prevent overheating. Optimum operating temperatures can be maintained with a properly serviced system even at ambient temperatures up to 110°F.

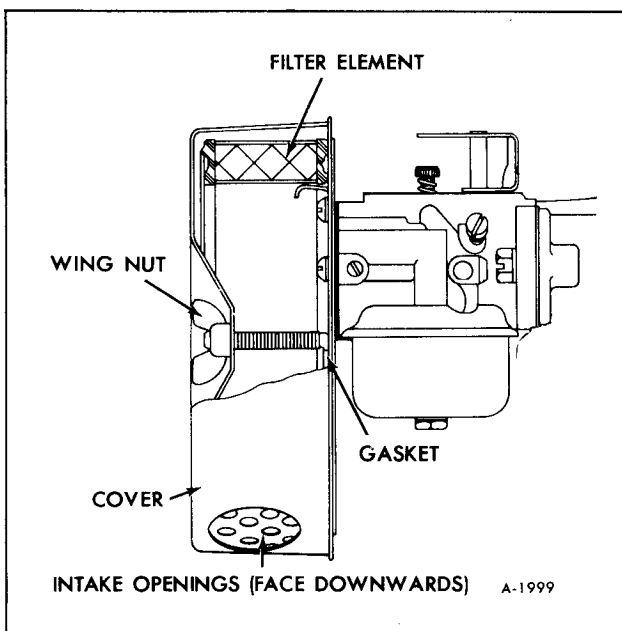

Figure 23–Air Cleaner

## GOVERNOR ADJUSTMENT (FIGURE 24)

The governor functions to maintain engine speed under changing load conditions and also acts as a speed limiting device. Governor is set in the factory and further adjustment should not be required unless linkage works loose or becomes disconnected. Readjustment should be made if engine surges with changing load or if speed drops considerably when a normal load is applied.

**INITIAL ADJUSTMENT:** With engine stopped, loosen (do not remove) hex nut securing governor arm to governor cross shaft. Grasp end of cross shaft with pliers and turn shaft as far as possible in counterclockwise direction – tab on shaft will stop internally against governor gear mechanism. Hold shaft in this position, pull governor arm all the way away from carburetor then retighten governor arm nut to complete initial adjustment.

**SPEED ADJUSTMENT:** This engine must be operated at 1890 RPM no load or 1800 RPM at full load. If frequency or overspeed condition is suspected, check RPM with hand tachometer or frequency meter and readjust; loosen speed adjusting nut to decrease, or tighten to increase speed.

**SENSITIVITY ADJUSTMENT:** If speed drops considerably when a normal load is applied, governor should be set for greater sensitivity. If set too sensitive, speed surging will occur with changing load. Governor sensitivity is adjusted by repositioning governor spring in holes provided on arm and speed control brackets. Increase tension on spring (and sensitivity) by moving spring hooks into holes spaced further apart – conversely, decrease sensitivity by reducing tension on spring.

## CARBURETOR ADJUSTMENT (FIGURE 25)

Lack of power and black sooty exhaust smoke usually indicates that fuel mixture is too rich. An “overrich” mixture may also be caused by a clogged air cleaner – check this before readjusting carburetor. Fuel mixture may be too lean if engine “skips” or backfires.

**MAIN FUEL ADJUSTMENT:** For preliminary setting, turn MAIN FUEL screw in clockwise direction until it bottoms lightly (do not force) then back

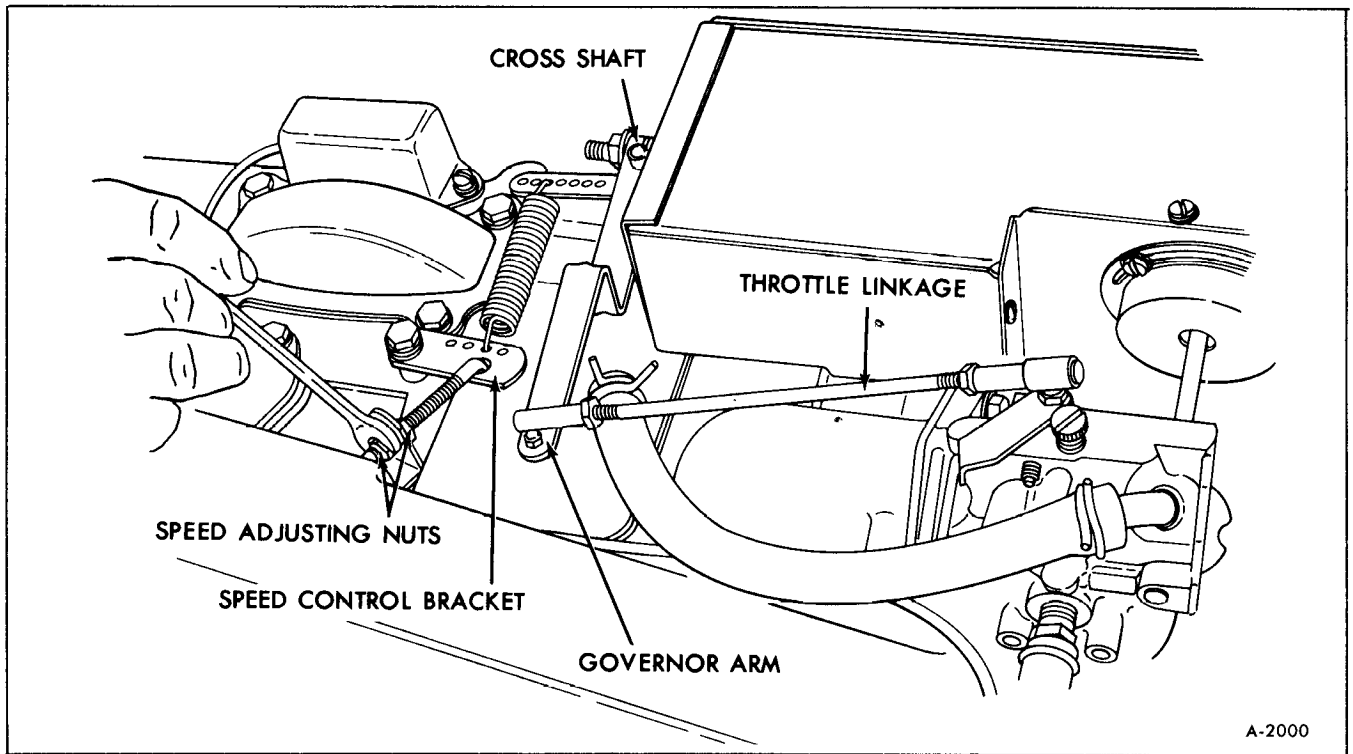

Figure 24-Governor Adjustment

out 2-1/2 turns. With engine thoroughly warmed up and running at 1800 RPM and full load, turn MAIN FUEL screw in until engine slows down (lean setting) then turn screw out until engine regains speed and then starts to slow down (overrich setting). Turn screw back in until it is positioned halfway between

lean and overrich settings – when properly adjusted, engine will operate with steady governor action.

**IDLE ADJUSTMENT:** On this generator set, the idle system functions only as the engine comes up thru idle range to 1800 RPM. For this reason, idle system has only a momentary effect. To adjust, stop engine then turn IDLE FUEL screw all the way in (clockwise) until it bottoms lightly (do not force screw), then back out 3 turns – no further adjustment is needed.

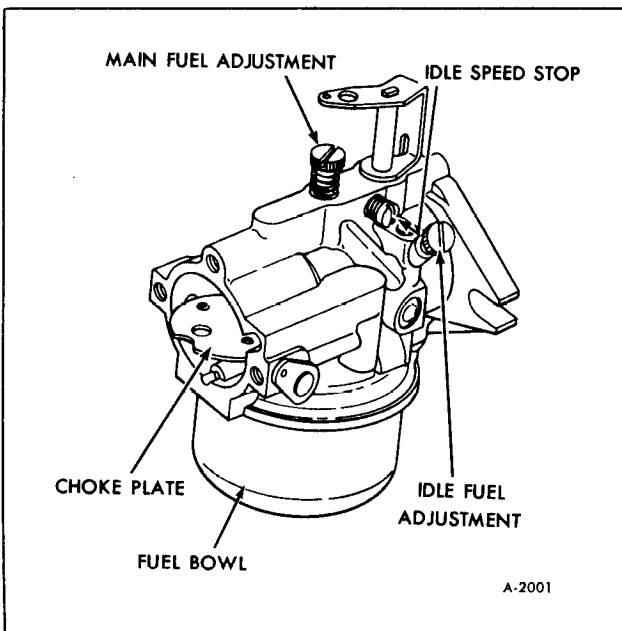

Figure 25-Carburetor Components and Adjustments

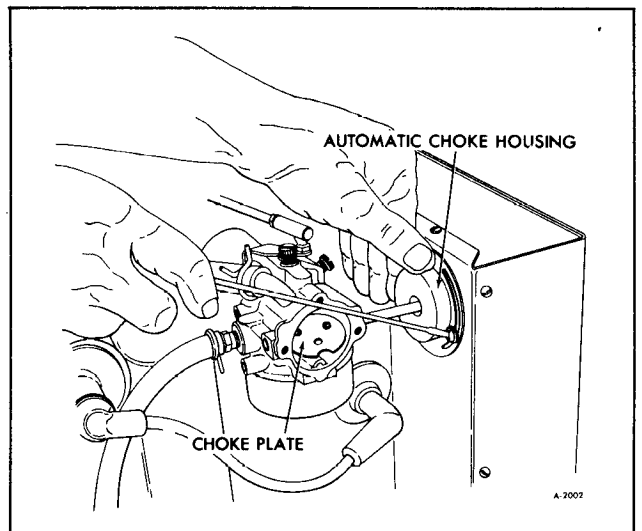

Figure 26-Automatic Choke Adjustment



## AUTOMATIC CHOKE (FIGURE 26)

Chokes are set at the factory but may have to be readjusted to suit local conditions. Remove air cleaner from carburetor to observe position of choke plate. Choke adjustment must be made on cold engine. If starting in extreme cold, choke should be 35° from full open position before engine is started. A lesser degree of choking may be needed in milder temperatures. If adjustment is required, loosen screws which secure the choke housing to the ductwork and rotate the housing until the choke plate is 35° from full open position (with ambient 75° temperature).

## IGNITION SYSTEM

Hard starting, roughness, low power and erratic operation are often attributed to faulty ignition. All ignition components must be in top condition and the ignition spark must be properly timed to maintain good performance.

*Spark Plug:* Every 100 hours remove plug and

check condition. Good operating conditions are indicated if plug has light coating of gray or tan deposit. A dead white, blistered coating could indicate overheating. A black (carbon) coating may indicate an "overrich" fuel mixture caused by clogged air cleaner or improper carburetor adjustment. Do not sandblast, wire brush, scrape or otherwise service plug in poor condition – best results are obtained with new plug. Set standard type spark plug gap at .025". Tighten plug to 22 ft. lbs. (264 in. lbs.) torque when installing.

*Breaker Points:* (figure 27) Every 200 hours breaker points should be inspected and serviced as needed. If oxidized, dirty or oily, clean with coarse cloth – do not use emery cloth or sandpaper. Slightly pitted points can be dressed with point file – replace badly pitted or burned points. The gap must be adjusted after points are serviced or replaced since this setting establishes ignition timing. To adjust, crank engine until points are at maximum opening – check with feeler gauge. If gap is not .020", loosen adjusting screw then shift movable plate until .020" gap is obtained. After retightening screw, recheck to make sure gap is still properly set, then replace cover.

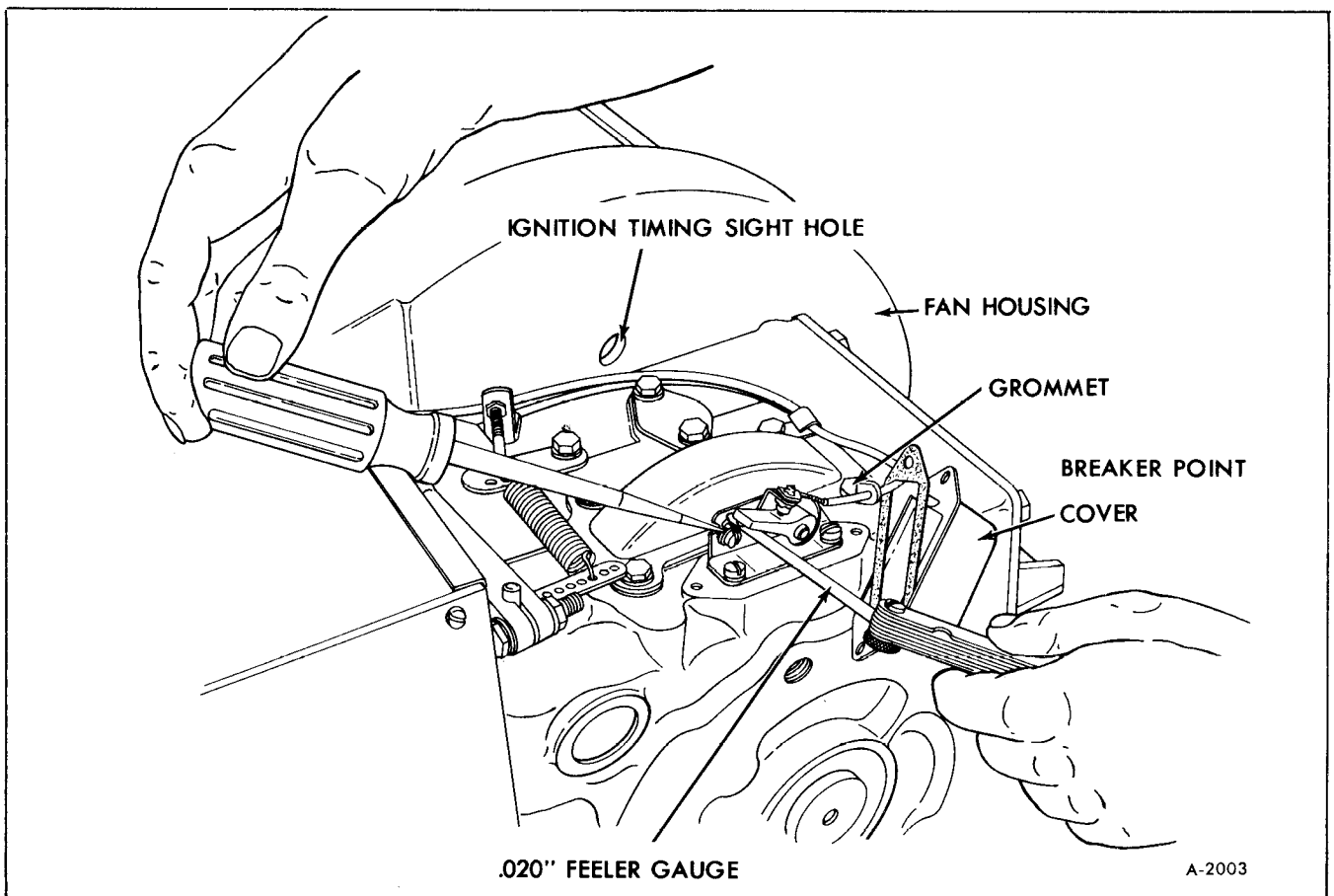

Figure 27—Adjusting Breaker Points

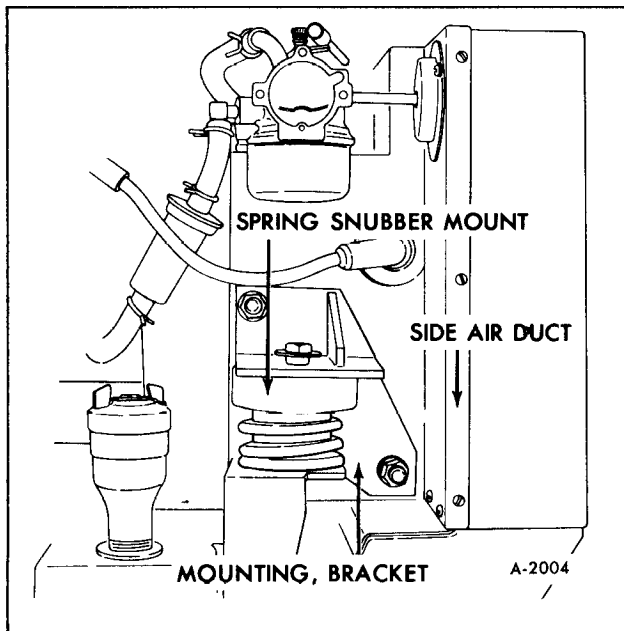

Figure 28-Cylinder Head Removal

### CYLINDER HEAD SERVICE

To retain top operating efficiency and performance, the cylinder head should be removed for carbon cleaning after every 200 operating hours. To service the head, pull the generator set out of the compartment, lift the engine end of the unit then disconnect the spring snubber mount from the

mounting bracket attached to the cylinder head. Remove the mounting bracket, side air duct and the cylinder head (Refer to figure 28).

To remove the carbon, use a piece of wood or plastic material to avoid scratching the aluminum head. After cleaning, install a new cylinder head gasket and reinstall the cylinder head – tighten head bolts to 25 foot-pounds torque as shown in Figure 14.

### FUEL PUMP (FIGURE 29)

A serviceable fuel filter element is located inside the electric fuel pump. Remove the cover of the fuel pump and service this element at the end of each operating season or more frequently if an unusual amount of impurities are noted in the see-thru filter. To clean the element, swish in cleaning solvent or in fresh, clean gasoline. Make sure that the cover is securely tightened after reinstalling the serviced filter element.

This fuel pump includes a check valve which prevents drain back of the fuel when the set stops. If the pump malfunctions, replace the complete unit.

### VALVE CLEARANCE ADJUSTMENT

After each 500 hours of operation, remove the

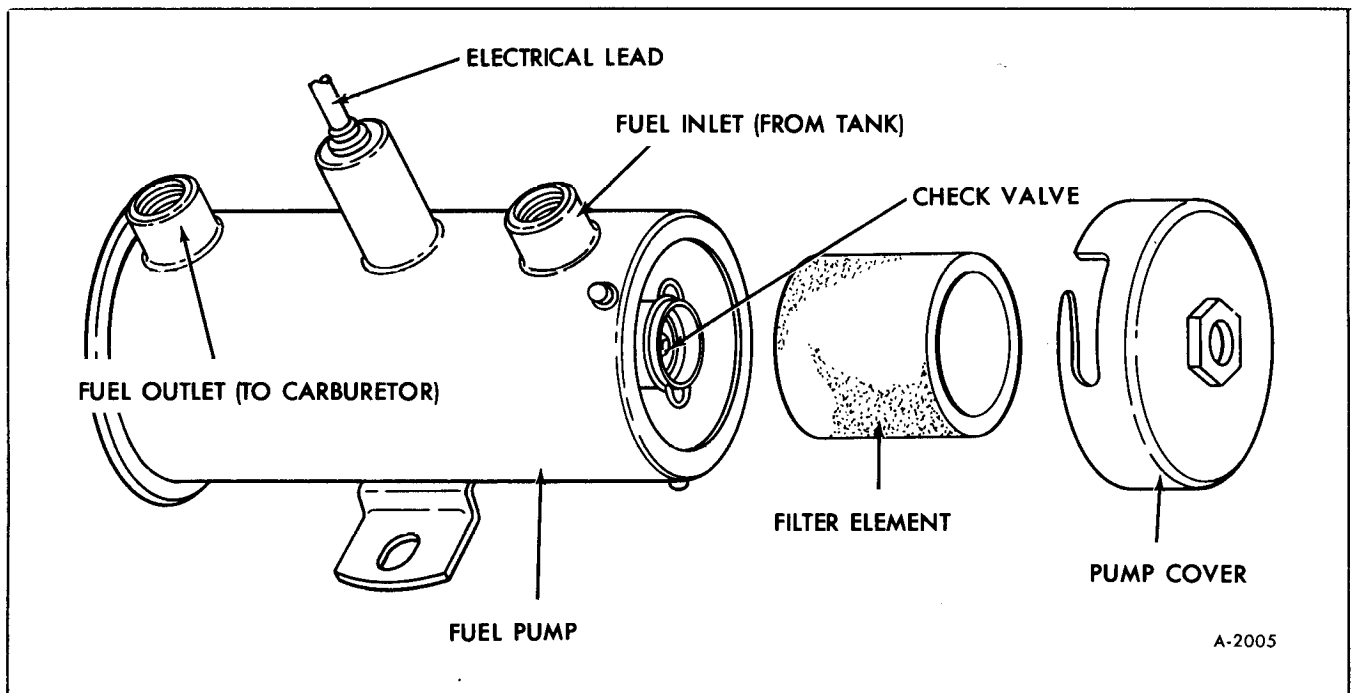

Figure 29-Electric Fuel Pump

valve cover and check the clearance between the end of the valve stems and the tappets. Clearance is checked when both valves are closed at which point the cam will have no effect on the tappets. Check clearance with cold engine. Cold clearance should be set at .008 - .010 on the intake valve and .017 - .020 on the exhaust valve. To adjust, turn adjusting screw on tappet in or out until proper clearance is obtained. Adjusting screw is self-locking. Reinstall crankcase breather components in proper sequence after adjusting valve clearances.

## GENERATOR SERVICE

### (FIGURE 30)

Generators do not normally require service on a regular basis; however, it is a good idea to remove the end cover and check the commutator and brushes at least every six months (or every 50 hours) or more often under dusty, dirty conditions. Make a visual check of the commutator first – if a thin skinlike film of uniform thickness is evident on the surface, this usually indicates normal operation – this film acts as

a lubricant and promotes longer brush life. If the surface is streaked or has ridges of dirt, clean it with a coarse cloth or, if this doesn't work, use fine sandpaper or a commutator stone – do not use emery cloth. Lift brushes and check surface – replace brush if unevenly worn or when worn down to about 5/16" or 1/2 original length. Use correct replacement brushes only – substitutes may not be of correct material and will wear out rapidly or cause commutator damage. Other common causes for rapid brush wear are wrong brush tension, rough commutator surface, high mica on commutator and brush chatter. Blow dust out with dry compressed air after servicing.

## CYCLIC COMPENSATOR

### (FIGURE 31)

At the relatively low speed of 1800 RPM, the speed of a single cylinder engine decreases slightly as the piston approaches the ignition point on the compression stroke and increases on the following power stroke. Although the speed change is hardly perceptible, the associated change in voltage is noticed as an

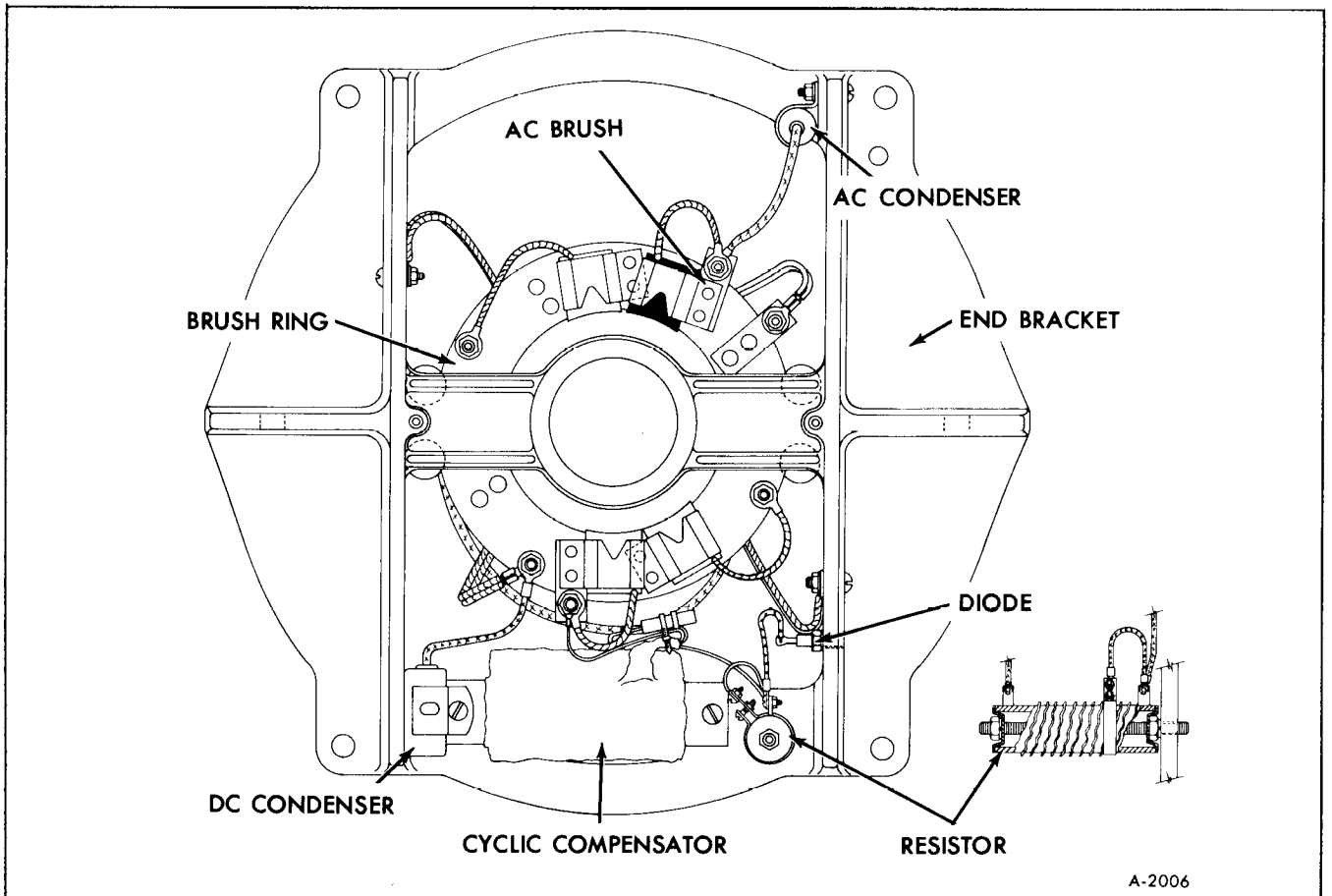

Figure 30—Generator With End Cover Removed For Brush Service

annoying flicker of the lights. The Cyclic Compensator momentarily functions as a voltage regulator to keep the voltage within specific limits where the variation will not cause flicker. It does this through an electronic circuit which is triggered by the engine ignition breaker points. The Cyclic Compensator shorts out the field resistor to increase field current during the "slow" or compression portion of the cycle which, in turn, restores the voltage to acceptable levels. The resistor is kept in the circuit while the piston is on the remaining strokes. The field resistor is adjusted during run-in tests at the factory for the best compensation – the minimum resistance setting is 3.0 ohms while the maximum is 3.8 with an average of about 3.5 ohms. If the resistance value is lowered, voltage will increase; however, this also reduces the anti-flicker effect. Increasing the resistance reduces voltage but increases the anti-flicker effect. Because of this effect on voltage, the resistor should not be readjusted out of these limits. **CAUTION: DO NOT** adjust the resistor when set is running – compensator may fail as a result if this is done.

and stopping the generator set. The switch must be held in the START position until the engine starts running and held in the STOP position until the engine comes to a complete halt. It also provides regulated battery charging for maintaining charge in the generator set battery. The engine is cranked by the exciter by means of a 12 volt - negative ground storage battery. The controller has a safety shut-down circuit which functions when a low oil level condition occurs. The sequence of operation is briefly outlined as follows:

1. Press and hold Start button until set starts.
2. Cranking contactor C energizes.
3. Engine cranks and runs.
4. Relay ICR energizes.
5. Power supplied to load.
6. Press and hold stop switch until set stops.

### CONTROLLER (FIGURE 32)

The controller includes a push button for starting

**BATTERY CHARGING:** Charging is provided from the exciter thru the contact of relay ICR and parallel resistors R2 and IR2. Regulator relay RR senses battery voltage and automatically varies the charge rate from 6 to .3 amps.

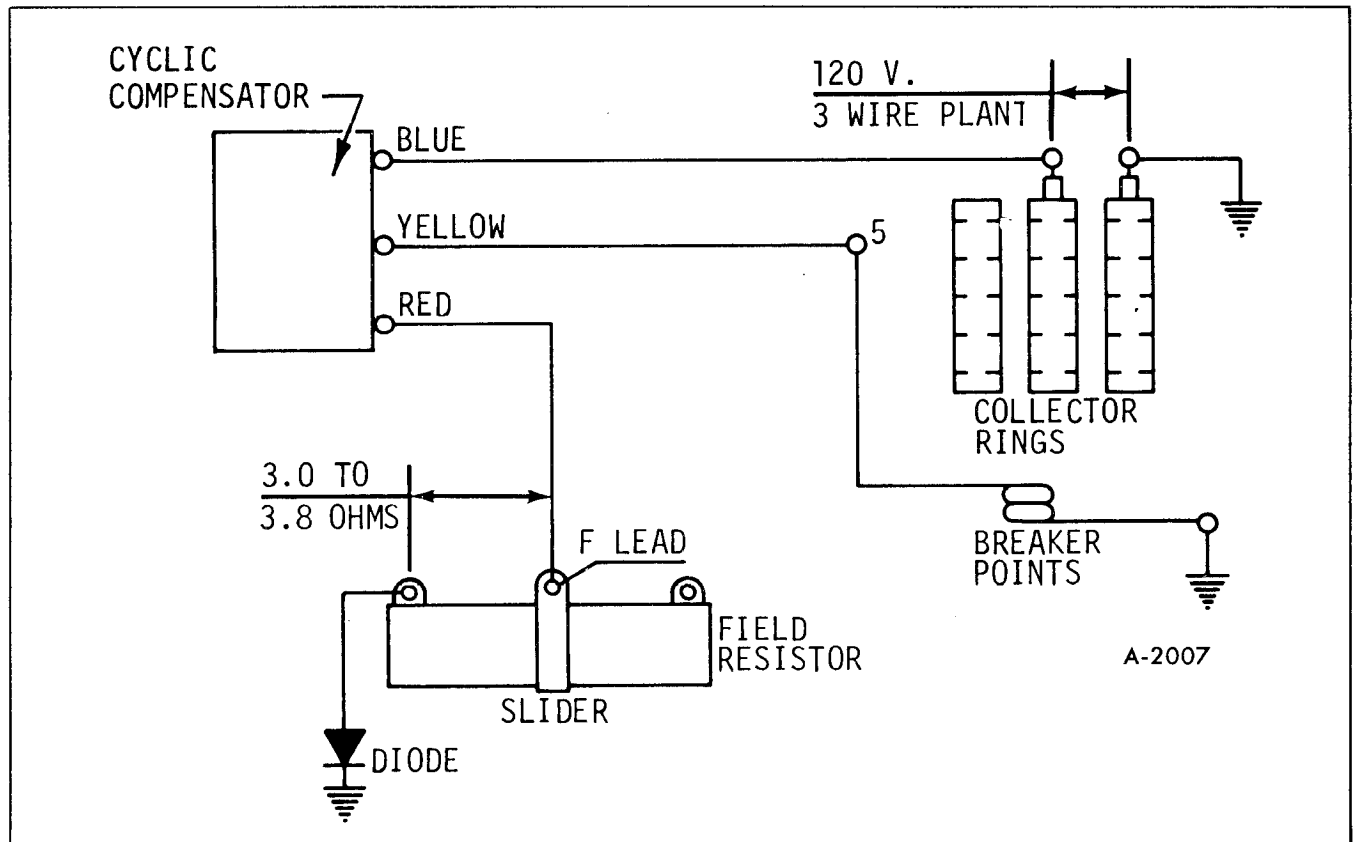
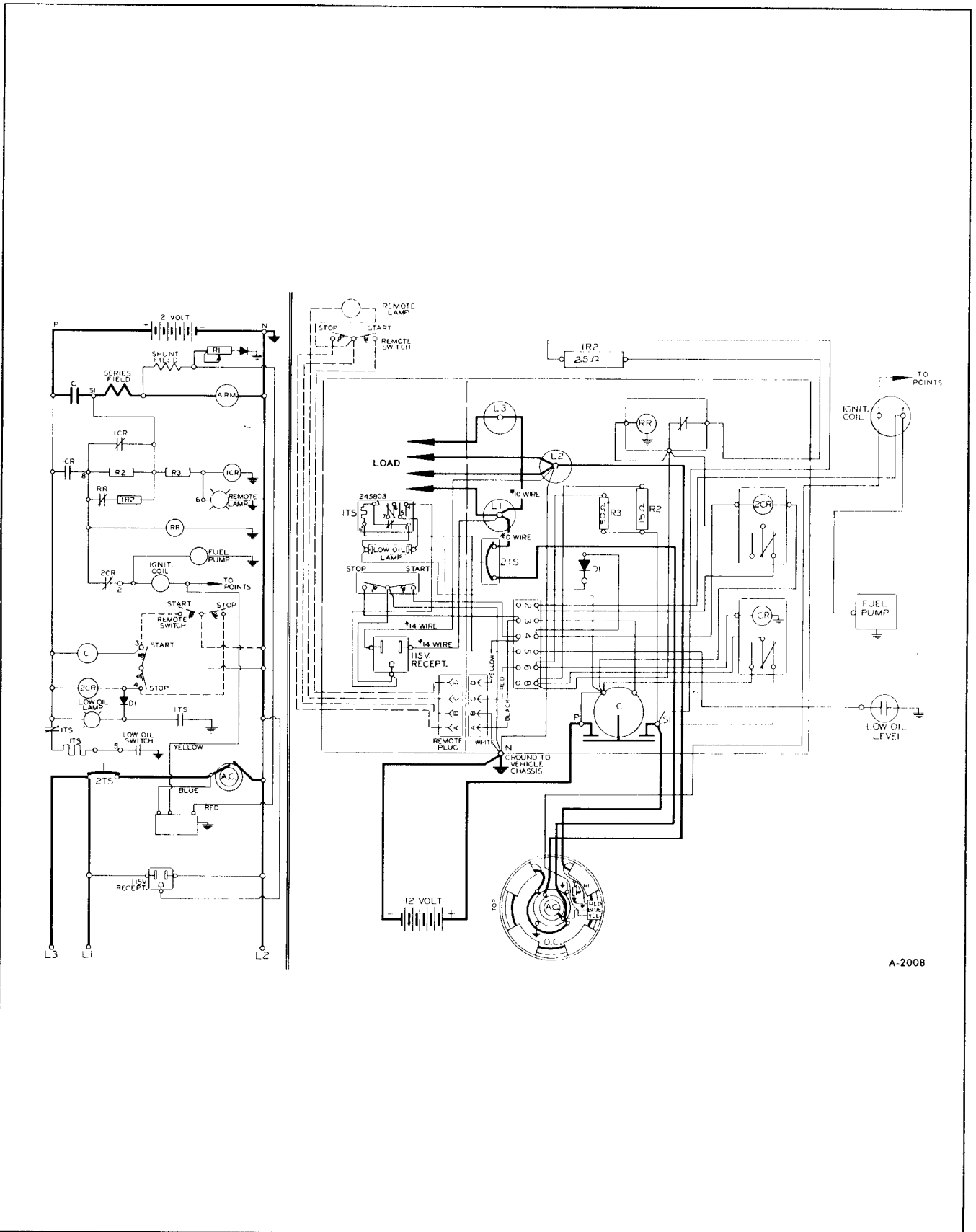

Figure 31–Cyclic Compensator Circuit



A-2008

Figure 32—Kohler Motor Generator Wiring Diagram

**LOW OIL SHUT-DOWN:** This circuit includes a float switch mounted in the oil pan, a time delay thermal switch and a low oil level indicator lamp. The lamp lights and the thermal switch trips when the set shuts down on low oil level. To restart, the oil must be added to proper level and the oil reset button (on cover) pressed.

**CIRCUIT BREAKER:** The circuit breaker (2TS) protects the main AC circuit against overload.

**OPERATIONAL SEQUENCE:** Paths of current in the various steps of operation may be traced as follows:

1. Press Start button to connect battery negative to solenoid coil C. Battery current flows to terminal P, coil of cranking contactor C, terminal 3, start switch to ground and back to the battery.

2. Cranking contactor C energizes allowing heavy current from battery to flow to terminal P, contacts of C, terminal S1, cranking series field of generator, exciter armature to ground and back to the battery. Current also flows thru the normally closed contacts of ICR to terminal 8, thru normally closed contacts of 2CR to terminal 2, to the ignition coil and electric fuel pump and back to ground.

3. Engine cranks and runs: After engine starts and runs, release start switch.

4. Relay ICR energizes: As exciter voltage builds, relay ICR energizes. Due to a higher voltage potential of the exciter, current will flow from the exciter thru the series field to S1, thru resistor R2 and IR2, thru normally closed contacts of relay RR to terminal 8, thru now closed contacts of relay ICR to the battery. Regulator relay RR energizes only when battery voltage reaches approximately 14.2 volts. This will break the current path thru resistor IR2. The R2 resistor (greater resistance) will allow a smaller amount of current to flow to the battery.

5. Power is supplied to load – Power is furnished to the load from collector rings through the 2TS and terminals L1, L2 and L3.

6. Press stop switch to stop engine – To stop the generator set, press and hold the stop switch which energizes the 2CR relay causing 2CR contact to open. When 2CR contact opens, current to the fuel pump and to the ignition coil is disrupted, causing the engine to stop. This controller is designed so that remote start-stop switch is connected to terminals A, B, C and D.

# SPECIFICATIONS

Engine Model.....	KL341
Output - watts.....	4000
Output - voltage (regulation $\pm$ 5%).....	120
Cyclic Compensator Setting .....	3.5 ohms
Exciter Voltage .....	36 - 40
Battery charge rate-high .....	6 amps
Battery charge rate-low .....	.3 amps
Shunt Field Resistance - Cold .....	3 ohms
Shunt Field Resistance - Hot.....	3.7 ohms
Bore X stroke .....	3-3/4 x 3-1/4
Displacement (cubic inches) .....	35.89
Oil Capacity.....	3 Quarts
Spark Plug .....	AC CR 45L
Spark Plug Gap.....	.025"
Breaker Point Gap.....	.020"
Ignition Spark Run (Piston Degrees BTDC).....	20° BTDC
Battery (Negative Ground).....	12 Volt
Fuel (Regular Grade Gasoline) .....	90 Octane (min.)
Starting.....	Electric-Exciter Crank
<b>CYLINDER BORE</b>	
New Diameter .....	3.750"
Wear Diameter - Maximum .....	3.753"
Taper - Maximum .....	.0015"
Out of Round - Maximum .....	.005"
<b>CRANKSHAFT</b>	
End Play (Free) .....	.002-.030"
Crankpin - New Diameter.....	1.500"
Crankpin - Max. Out of Round .....	.0005"
Crankpin - Max. Taper .....	.001"
<b>CAMSHAFT</b>	
Running Clearance on Pin .....	.001-.0035"
End Play.....	.005-.010"
<b>CONNECTING ROD</b>	
Big End - Max. Diameter .....	1.5025"
Rod To Crankpin - Max. Clearance.....	.0035"
Small End - New Diameter.....	.87585"
Rod To Pin Clearance.....	.0003-.0008"
<b>PISTON - PISTON RINGS</b>	
Thrust Face - Max. Wear Diameter.....	3.7425"
Thrust Face to Bore Clearance.....	.007-.010"
Ring - Max. Side Clearance .....	.006"
Ring End Gap - New Bore.....	.010-.020"
Ring End Gap - Max. In Worn Bore.....	.030"
<b>VALVE - INTAKE</b>	
Cold Clearance - Valve to Tappet .....	.008-.010"
Valve Lift - Zero Lash .....	.324"
Stem to Guide - Max. Clearance .....	.0045"
Tappet Clearance in Block .....	.0008-.0023"
<b>VALVE - EXHAUST</b>	
Cold Clearance - Valve to Tappet .....	.017-.020"
Valve Lift - Zero Lash .....	.324"
Stem to Guide - Max. Clearance .....	.0065"
Tappet Clearance in Block .....	.0008-.0023"
<b>TORQUE SPECIFICATIONS</b>	
Spark Plug .....	18-22 ft. lbs.
Cylinder Head .....	25 ft. lbs.
Connecting Rod .....	300 in. lbs.



# SECTION 24D REFRIGERATOR

This section includes the following:

SUBJECT	PAGE NO.
Norcold Refrigerator .....	24D- 1
Instamatic Refrigerator .....	24D-10

## NORCOLD REFRIGERATOR

Contents of this sub-section are listed below:

SUBJECT	PAGE NO.
General Information .....	24D- 1
Norcold Refrigerator Trouble Diagnosis .....	24D- 1
Component Testing .....	24D- 2
Component Removal .....	24D- 5
Component Installation .....	24D- 8
Norcold Specifications .....	24D- 9

## GENERAL INFORMATION

The Norcold refrigerator operates on the 12-volt DC system of the vehicle. It uses the same principle as the standard domestic refrigerator. It has an electrically-operated compressor and uses freon as its refrigerating medium.

The swing motor type compressor, used on both the six and seven and one-half cubic foot model,

operates on A.C. voltage only. The six cubic foot model requires 20 volts A.C. and the seven and one half cubic foot model requires 23 volts A.C. An inverter-transformer assembly inverts 12 volts DC to 11 volts A.C., and then transforms this voltage to 20/23 volts A.C. This is then supplied to the swing motor compressor.

## NORCOLD REFRIGERATOR TROUBLE DIAGNOSIS

Problem	Possible Cause	Correction
Compressor does not run.	<ol style="list-style-type: none"> <li>1. Fuse "blown" in living area fuse block.</li> <li>2. Circuit breaker in refrigerator has "tripped."</li> <li>3. Faulty electrical source.</li> <li>4. Defective thermostat</li> <li>5. Defective inverter assembly.</li> <li>6. Open or short circuit in swing motor compressor.</li> </ol>	<ol style="list-style-type: none"> <li>1. Correct electrical problem that caused fuse to "blow" and replace fuse.</li> <li>2. Correct electrical problem that caused circuit breaker to trip and reset circuit breaker.</li> <li>3. Check 12-volt DC source at the point where it enters the inverter assembly. The problem may lie in the source and not in the refrigerator.</li> <li>4. Replace thermostat.</li> <li>5. Replace inverter assembly.</li> <li>6. Replace swing motor compressor.</li> </ol>



Problem	Possible Cause	Correction
Insufficient cooling, compressor runs.	<ol style="list-style-type: none"> <li>1. Improper thermostat setting.</li> <li>2. Overpacking of cabinet.</li> <li>3. Insufficient heat radiation at condenser.</li> <li>4. Excess frost build up in freezer compartment.</li> <li>5. Freon overcharge or undercharge.</li> <li>6. Insufficient voltage source.</li> <li>7. System "Freeze-up" or clogging. Clogging is indicated by a warm evaporator plate, a condenser at room temperature, and a low amp draw by the compressor.</li> </ol>	<ol style="list-style-type: none"> <li>1. Turn thermostat to higher setting. A setting of "3" should be adequate at ambient temperatures of 70° - 90°. When storing frozen food in freezing compartment a setting of "5" is recommended for the above temperature conditions.</li> <li>2. Space must be left in between food to allow for proper convective heat transfer.</li> <li>3a. At ambient temperatures above 110°F. the condenser will not be able to radiate enough heat to maintain sufficient cooling, even with a setting of "5".               <ol style="list-style-type: none"> <li>b. Dust may have collected on condenser restricting air flow and must be removed.</li> </ol> </li> <li>4. A frost build up of over one quarter inch should be avoided. Defrost refrigerator.</li> <li>5. Can be determined by testing compressor amperage. In either case the entire cooling system must be replaced.</li> <li>6. Check 12-volt D.C. supply.</li> <li>7. Shut-off system and let it cool down, start-up system let it run for 5 minutes, shut-off system for 5 minutes. Restart system. If system does not function repeat cycling. If this does not relieve the clog replace entire system.</li> </ol>
Refrigerator too cold, compressor runs constantly.	<ol style="list-style-type: none"> <li>1. Thermostat "sticking".</li> <li>2. Thermostat sensing bulb loose on evaporator plate mounting.</li> </ol>	<ol style="list-style-type: none"> <li>1. Replace thermostat</li> <li>2. Tighten mounting screws to make sure bulb has good contact with evaporator plate.</li> </ol>

## COMPONENT TESTING

### COMPRESSOR VOLTAGE

The refrigerator must be removed from vehicle to check compressor voltage. The voltage is checked at the compressor terminals with an A.C. voltmeter (figure 1).

The voltage at the compressor should be  $28.2 \pm 1$  volts A.C. for the six cubic foot model and  $32.5 \pm 1$  volts A.C. for the seven and one-half cubic foot model.

If the voltage at the compressor is not adequate the voltage source should be checked.

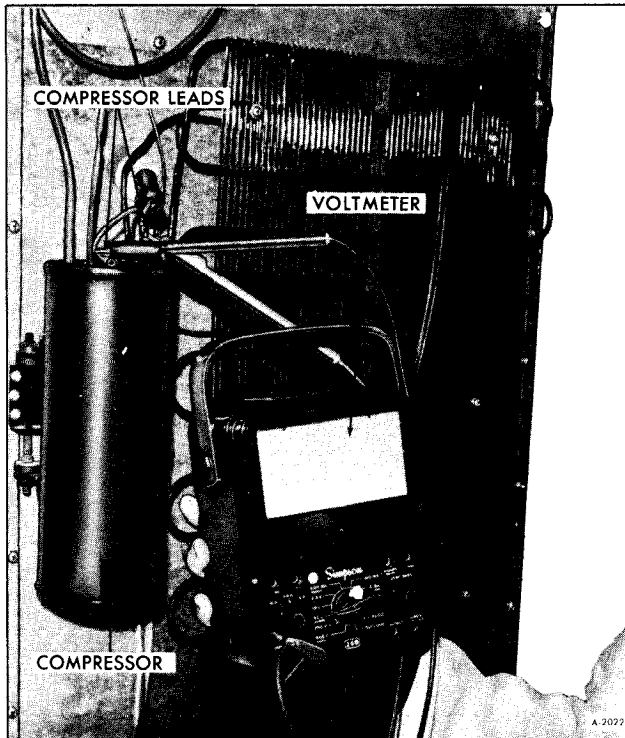

Figure 1—Checking Compressor Voltage

## COMPRESSOR AMPERAGE

One method of determining whether or not the proper amount of freon is in the cooling unit is to measure the number of amps drawn by the compressor.

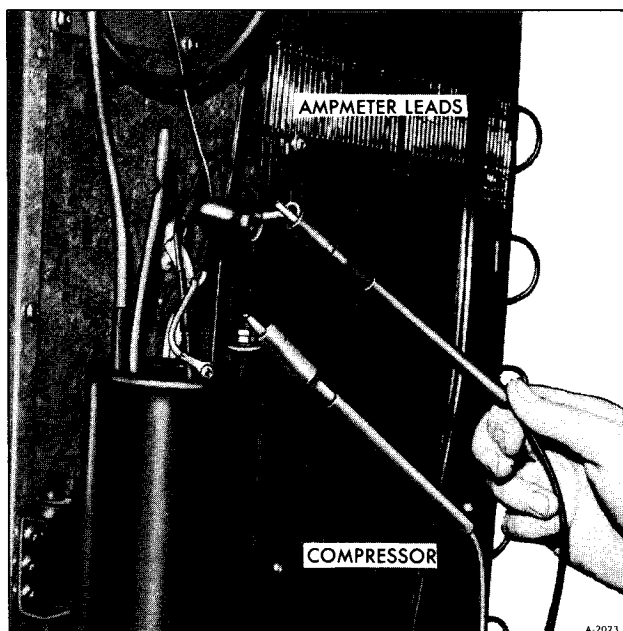

Figure 2—Checking Compressor Amperage

This is done by removing one of the compressor leads and connecting a 0-5 ammeter in series with the compressor (figure 2), a reading of approximately 2 amps should be read for the six cubic foot model and approximately 2.6 amps for the 7 1/2 cubic foot model.

If the amperage reading is high, this is an indication the system is undercharged. If a low reading is obtained the system is overcharged. If it is determined that the system is under or overcharged the entire cooling system must be replaced.

## TESTING THERMOSTAT

The thermostat may be tested by two different methods.

*The first method is,* gain access to the inverter assembly. Pull this assembly from the bottom of the refrigerator and disconnect the thermostat motor leads. Connect a ohmmeter to the thermostat leads (figure 3) and turn the thermostat to "5". There should be continuity. If not replace thermostat.

*Another method is,* to remove thermostat assembly from inside cabinet and connect a jumper wire between the two lead wires as shown in Figure 4. If the compressor begins to run replace the thermostat.

## INVERTER ASSEMBLY

Remove the inverter assembly from the bottom of the refrigerator. Unplug wiring harness from in-

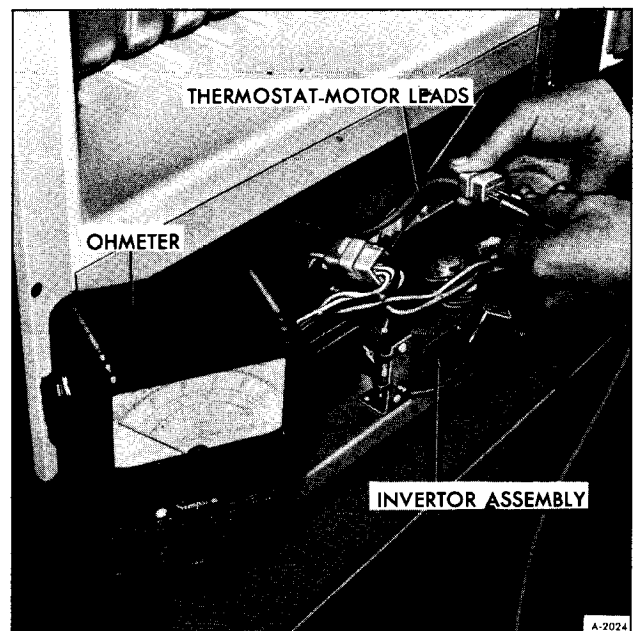

Figure 3—Checking Thermostat at Inverter

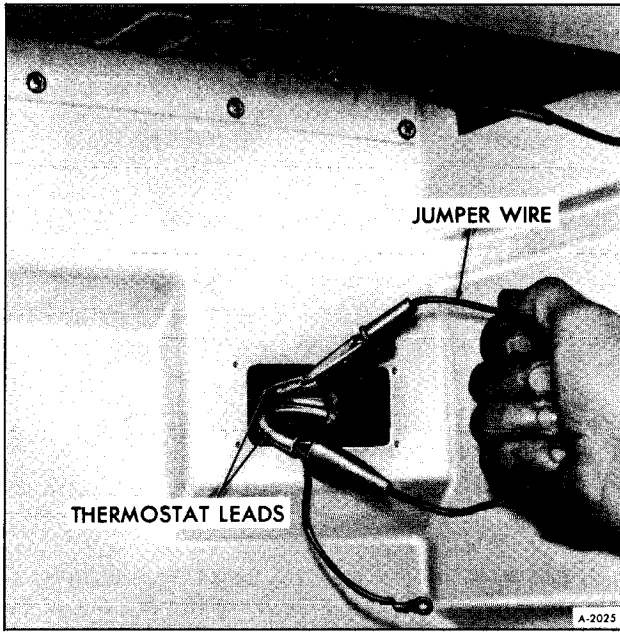

Figure 4-Jumper Wire at Thermostat

verter assembly. Install new inverter assembly, and turn on refrigerator. If refrigerator now functions properly the old inverter assembly was faulty and the new inverter assembly should remain installed in the refrigerator.

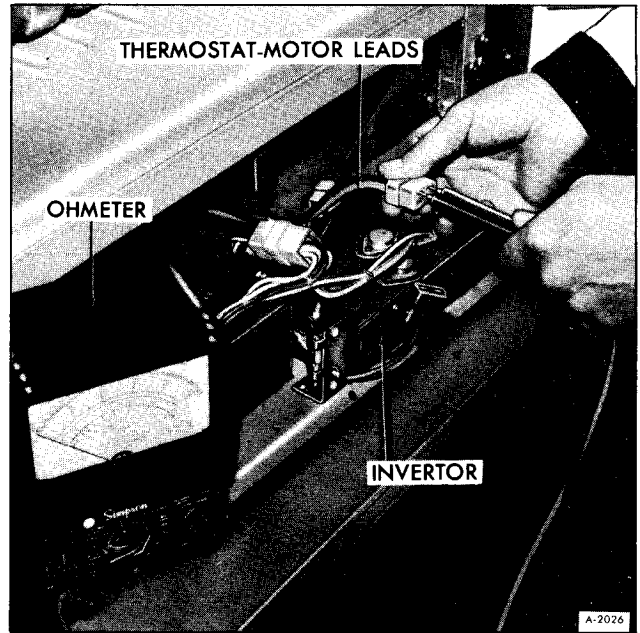

Figure 5-Testing Compressor Resistance

## SWING MOTOR COMPRESSOR RESISTANCE

At inverter assembly disconnect thermostat-motor leads. Connect a suitable ohmmeter across motor leads as shown in Figure 5. A reading of 2-3 ohms should be obtained. If the reading does not fall within this range the motor contains an open or a short. Then, entire cooling unit must be replaced.

# REFRIGERATOR REPLACEMENT

## REMOVAL

1. Remove door(s).
2. Remove kick plate from front of refrigerator.
3. Disconnect 12-volt source at electrical connector, which is located behind kick plate.
4. Remove four screws from sides of refrigerator as shown in Figure 6.
5. Slide unit out, and remove from vehicle.

## INSTALLATION

1. Position unit in opening.
2. Install four retaining screws (figure 6).
3. Reconnect 12-volt electrical connector behind kick plate.

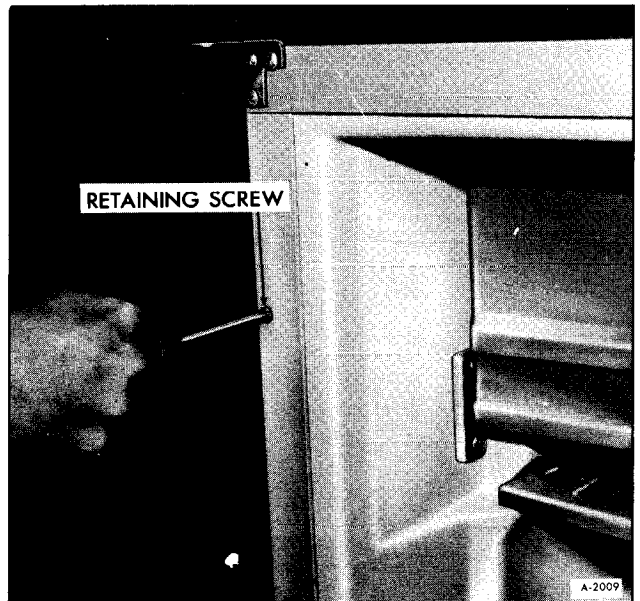

Figure 6-Removing Refrigerator Retaining Screws

4. Install kick plate.

5. Install door(s).

## COMPONENT REMOVAL

### DOOR REMOVAL (6 CU. FT.)

1. Remove screw at top of door hinge and release travel lock (figure 7).

2. Tilt door out at top and lift door up and off bottom hinge pin, as shown in Figure 8.

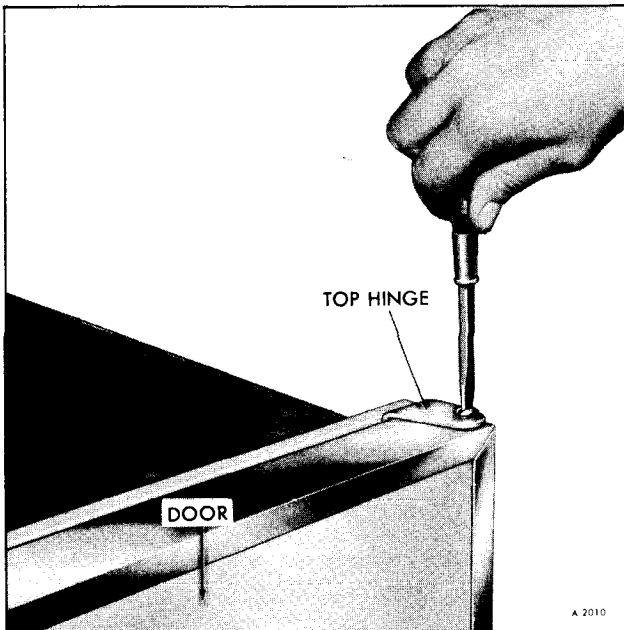

Figure 7—Removing Top Door Hinge

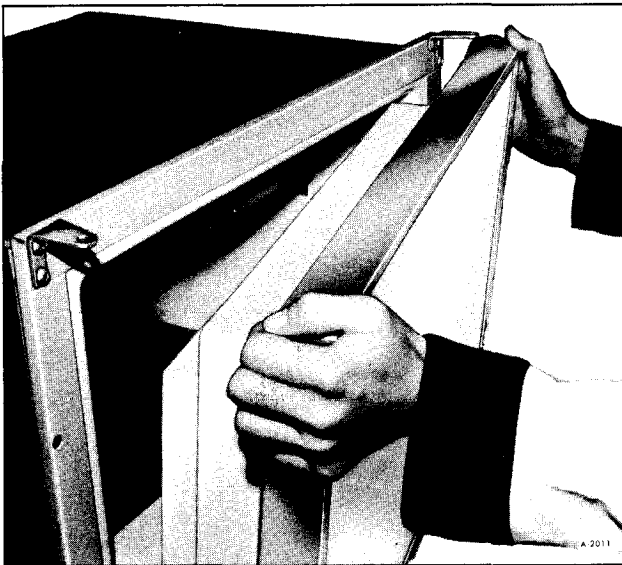

Figure 8—Removing Door

### DOOR REMOVAL (7 1/2 CU. FT.)

1. Remove screw top of freezer door hinge, release travel lock.

2. Tilt top of freezer door out and lift door off hinge.

3. Top of hinge pin is slotted to accept a screw driver. Remove this hinge pin (figure 9).

4. Tilt lower door out at its top and lift off bottom hinge pin.

### THERMOSTAT REMOVAL (FIGURE 10)

1. Remove four screws holding thermostat and its face plate to the back of the refrigerator cabinet.

2. Pull thermostat from cabinet wall, and disconnect three electrical leads from back of thermostat. Remove sensing tube from freezer tray.

3. Pull control knob off, and remove face plate from thermostat by removing retaining nuts and bolts.

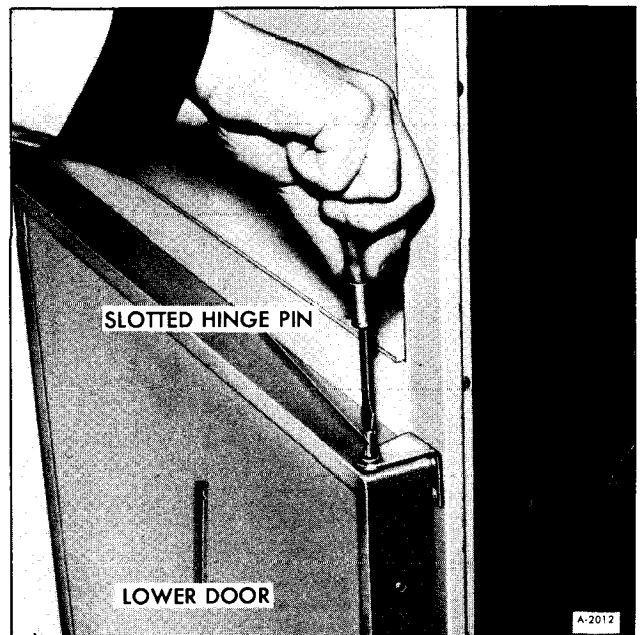

Figure 9—Removing Center Hinge Pin

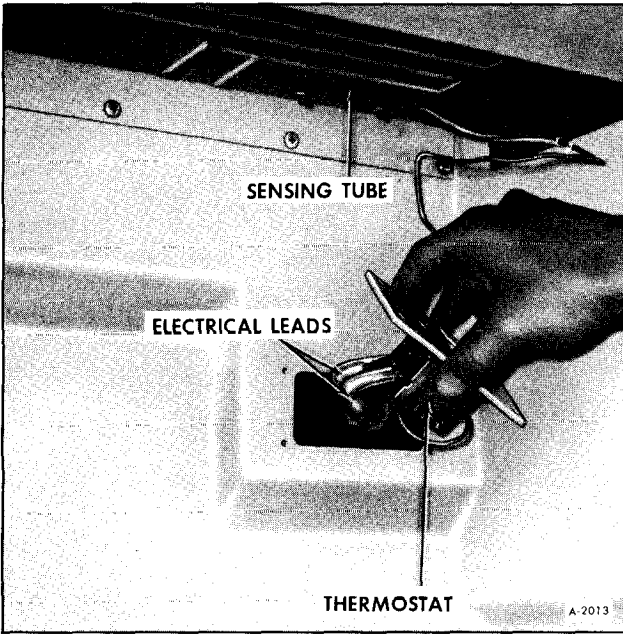

Figure 10—Removing Thermostat

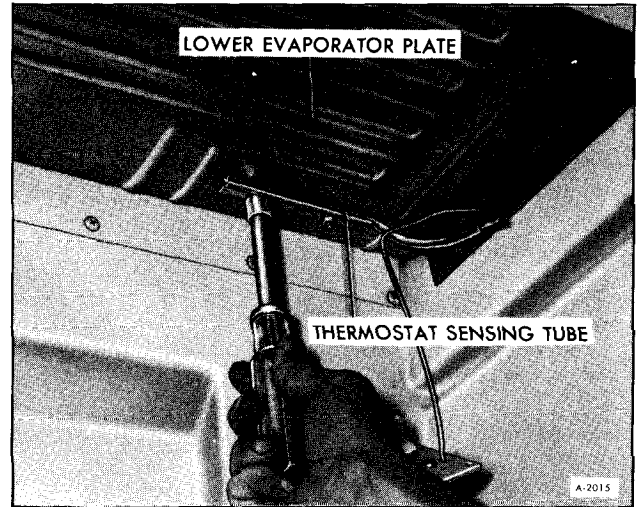

Figure 12—Removing Thermostat Sensing Tube

## COOLING UNIT REMOVAL

1. Remove refrigerator from vehicle.
2. Remove eight screws from upper and lower evaporator plates, four screws in each (figure 11).
3. Remove thermostat sensing element from lower evaporator plate by removing two screws (figure 12).
4. Remove ten screws from blind cover in back of evaporator plates.
5. Disconnect electrical leads to the compressor.

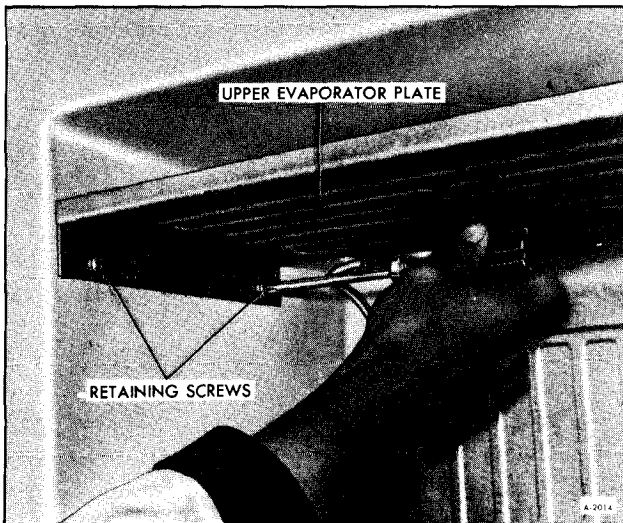

Figure 11—Removing Evaporator Screws

**CAUTION:** Care must be taken when removing or installing electrical leads to the compressor. The bottom nuts must not be loosened or tightened as the seals at these points may be damaged.

6. Remove putty from opening where capillary tube and discharge tube pass through back of cabinet.
7. Remove sheet metal plate from back of refrigerator as shown in Figure 13.

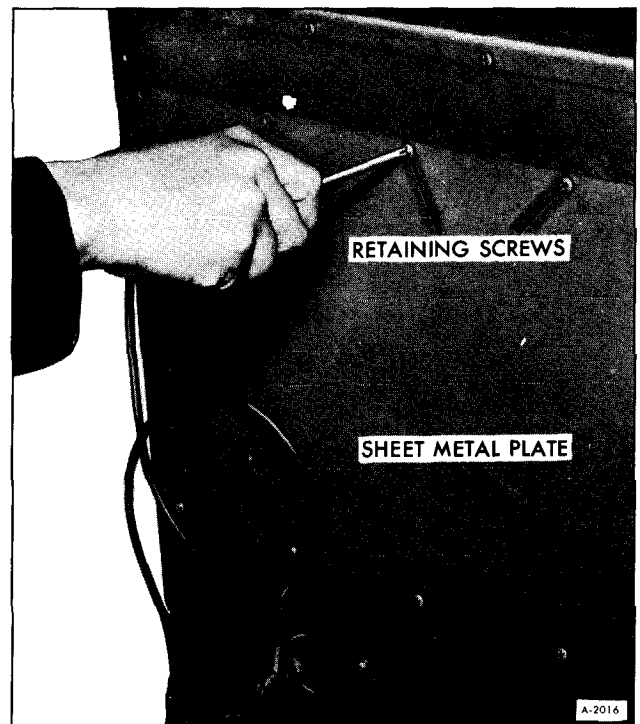

Figure 13—Removing Sheet Metal Plate

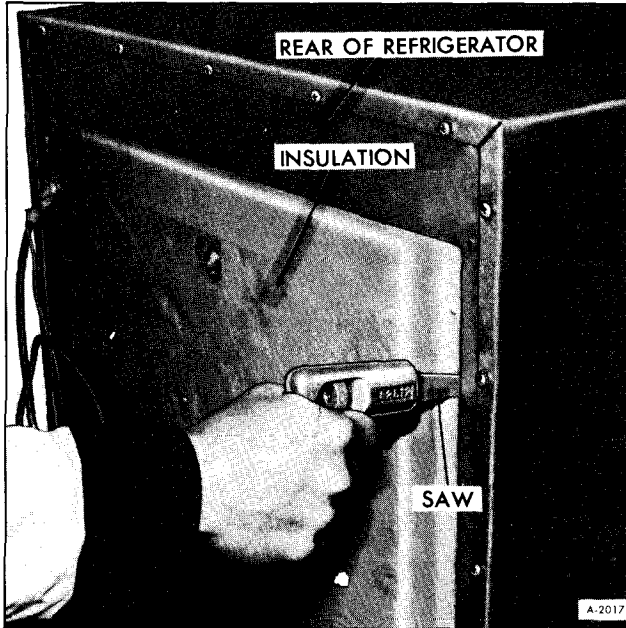

Figure 14—Cutting Insulation

8. Remove eight retaining screws from condenser.
9. Remove mounting screws from compressor.
10. Cut out insulation from opening where sheet metal plate was removed (figure 14).
11. Pull evaporator plates through opening and remove cooling unit as an assembly.

## INVERTER ASSEMBLY REMOVAL

1. Remove kick plate.

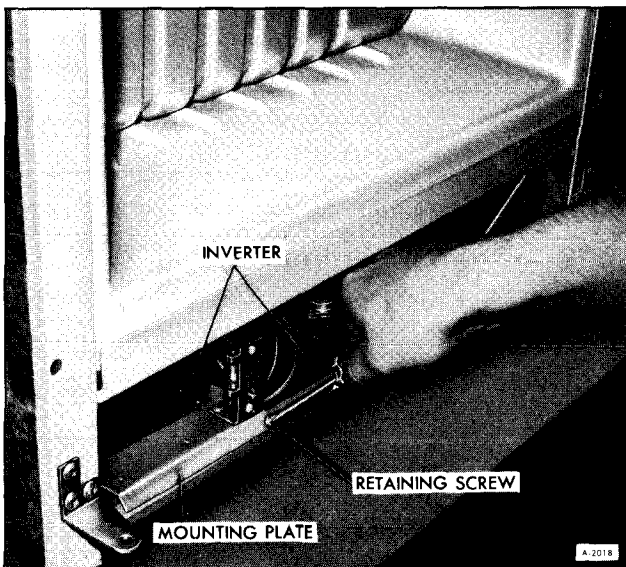

Figure 15—Removing Inverter Assembly



Figure 16—Disconnecting Wiring

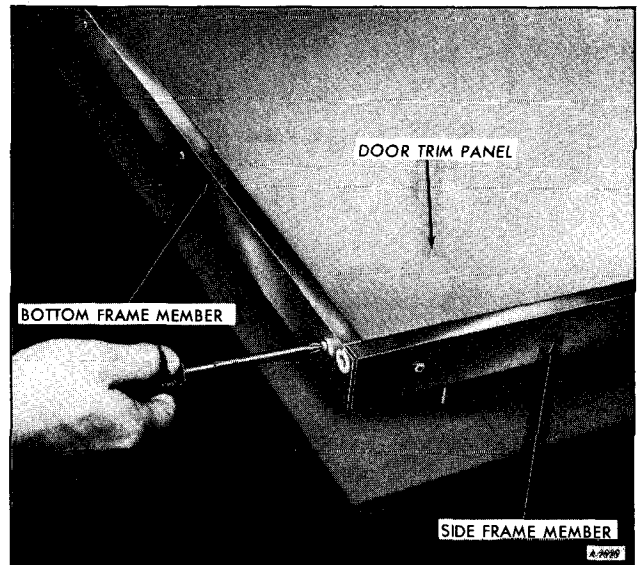

Figure 17—Removing Bottom Frame

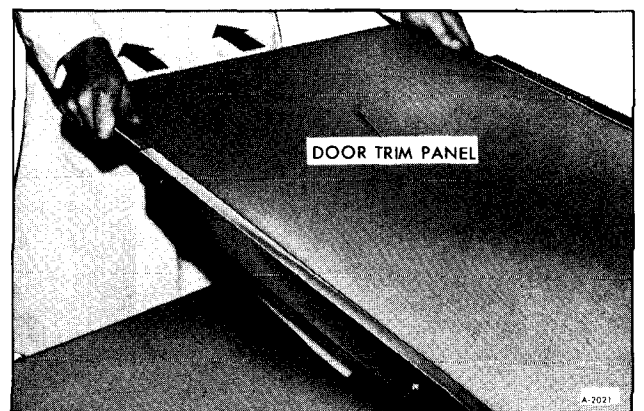

Figure 18—Removing Trim Panel

2. Remove screw at front of inverter assembly mounting plate (figure 15). Lift assembly out of refrigerator.

3. Disconnect wiring from back of assembly (figure 16).

## **DOOR PANEL REMOVAL**

1. Remove door(s) and place door on flat surface liner side down.

2. Remove bottom frame member by removing three screws, as shown in Figure 17.

3. Loosen three screws on both side frame members.

4. Trim panel can now be removed by sliding it out the bottom (figure 18).

# **COMPONENT INSTALLATION**

## **DOOR INSTALLATION (6 CU. FT.)**

1. Place door on bottom hinge pin, push door to its normal position.

2. Install top hinge pin (figure 7), and fasten travel lock.

## **DOOR INSTALLATION**

### **(7-1/2 CU. FT.)**

1. Place lower door on bottom hinge pin and push door to its normal position.

2. Install center hinge pin (figure 9).

3. Place freezer door on its lower hinge pin and push door to its normal position.

4. Install top hinge pin and secure travel lock.

## **THERMOSTAT INSTALLATION**

1. Install face plate to thermostat with two nuts and bolts.

2. Install three electrical leads shown in Figure 10.

3. Install sensing tube to freezer tray.

4. Position thermostat on cabinet wall and secure with four screws.

5. Install control knob.

## **INVERTER ASSEMBLY INSTALLATION**

1. Connect wiring as shown in Figure 16.

2. Place inverter assembly in position and secure with screw at mounting plate, as shown in Figure 15.

3. Install kick plate.

## **COOLING UNIT INSTALLATION**

1. Through opening in back of refrigerator position evaporator plates in cabinet.

2. Install mounting screws in compressor.

3. Install eight mounting screws in condenser.

4. Replace foam insulation in rear opening.

5. Install blind cover to inside of cabinet behind evaporators.

6. Secure evaporators with eight screws (figure 11).

7. Install sheet metal plate over rear opening (figure 13).

8. Apply sealer to seal hole where capillary and return tubes pass through.

9. Connect electrical leads to compressor.

10. Reinstall thermostat sensing tube to bottom of lower evaporator plate.

11. Install refrigerator in Motor Home.

**DOOR PANEL INSTALLATION**

1. Slide panel up into position through the bottom.
2. Tighten screws on side frame member.

3. Install bottom frame member and secure with three screws (figure 17).

4. Mount door(s) back on refrigerator.

**NORCOLD SPECIFICATIONS**

Model	6 Cubic Ft.	7.5 Cubic Ft.
Power	40 Watts	60 Watts
Amps Required	2 Amps	2.6 Amps
Volts Required	28.2 Volts A.C.	32.5 Volts A.C.
Compressor Motor Resistance	2-3 Ohms	2-3 Ohms
Compressor Motor Speed	60 Strokes/Sec.	60 Strokes/Sec.
Inverter Output	11 Volts A.C.	11 Volts A.C.
Transformer Output	28.2 Volts A.C.	32.5 Volts A.C.
Input Voltage	12 Volts D.C.	12 Volts D.C.



# INSTAMATIC REFRIGERATOR

Contents of this sub-section are listed below:

SUBJECT	PAGE NO.
General Information .....	24D-10
Instamatic Refrigerator Trouble Diagnosis (Gas) .....	24D-11
Instamatic Refrigerator Trouble Diagnosis (Electric) .....	24D-13
Refrigerator Replacement .....	24D-14
Component Removal .....	24D-15
Cleaning and Inspection .....	24D-18
Component Installation .....	24D-20
On Vehicle Adjustments .....	24D-21

## GENERAL INFORMATION

The continuous absorption type of cooling unit is operated by the application of a limited amount of heat by either gas or electricity. No moving parts are employed.

The unit consists of four main parts the boiler system, condenser, evaporator and absorber. All parts are connected by tubes, the whole construction being of steel welded together. The unit can either be run on electricity or gas.

The unit charge consists of a quantity of ammonia, water and hydrogen under pressure sufficient to condense ammonia at ordinary room temperature. The unit is then sealed off.

Air circulating over the fins of the condenser takes up sufficient heat from the ammonia vapor to cause it to condense to liquid ammonia in which state it flows into the low temperature evaporator, situated at the base of the frozen storage compartment.

The ammonia passes from the low temperature evaporator into the high temperature evaporator, situated at the rear inside the cabinet.

The low temperature evaporator and the high temperature evaporator are also supplied with hydrogen. The hydrogen passes across the surface of the ammonia and lowers the ammonia vapor pressure sufficiently to allow the liquid ammonia to evaporate. The evaporation of the ammonia extracts heat from the evaporator and from the food storage space, thereby lowering the temperature inside the refrigerator.

The mixture of ammonia and hydrogen vapor passes from the evaporator to the absorber vessel.

Entering the upper portion of the absorber is a continuous trickle of weak ammonia solution. This weak solution, flowing down through the absorber, comes into contact with the mixed ammonia and

hydrogen gases and readily absorbs the ammonia from the mixture, leaving the hydrogen free to rise through the absorber coil and to return to the evaporator.

The hydrogen thus circulates continuously between the absorber and the evaporator.

The strong ammonia solution produced in the absorber flows down to the absorber vessel and thence to the boiler system, thus completing the full cycle of operation.

The liquid circulation of the unit is purely gravitational. It is therefore essential that the unit stands upright.

Heat is generated in the absorber by the process of absorption. This heat must be dissipated into the surrounding air. Heat must also be dissipated from the condenser in order to cool the ammonia vapor sufficiently for it to liquefy. Free air circulation is therefore necessary over the absorber and condenser.

The whole unit operates by the heat applied to the boiler system and it is of paramount importance that this heat is kept within the necessary limits and is properly applied.

## AUTOMATIC FLAME FAILURE SAFETY DEVICE

The thermoelectric safety device functions as follows:

By pressing the pushbutton, the gas valve is opened and the gas can pass the housing on to the burner. At the burner, the feeler is located. When the gas flame of the burner is lit, some heat is transferred to the feeler. The hot junction of the thermocouple

is thus heated and an electric current is generated. This current passes through the copper wire, the electromagnet in the case and back through the outer tube. As soon as the electric current and magnetism is generated, the valve is attracted toward the case, allowing the gas to pass, whereby the pushbutton may be released.

As long as current is flowing, the valve is kept open and allows gas to pass to the burner. When the flame is extinguished, the heat transfer to the hot junction is interrupted and no electric current is generated. The valve is then forced back by the spring and the gas flow through the valve is closed.

## FLUE SYSTEM

The flue system consists of the following parts:

1. Central tube (built-in part of the boiler system and cannot be removed).
2. Flue with bracket.
3. Flue baffle with support wire.

The purpose of the flue system is to provide a draft which will pull the burner flame into the central tube and supply sufficient primary and secondary air to the flame.

The right flue draft will not be obtained before the burner has warmed up the flue system to the proper temperature.

The flue baffle which is inserted in the central tube distributes the heat produced by the burner to the boiler system.

It is important that the correct size of baffle is used and that it is correctly located in the central tube in order to obtain the best cooling performance.

## IGNITION DEVICE

A piezoelectric ignition device is used to ignite the gas burner. It is completely self contained and requires no outside electrical source.

# INSTAMATIC REFRIGERATOR TROUBLE DIAGNOSIS (GAS)

## REFRIGERATOR TOO COLD

1. Dirt in thermostat or valve seat.  
Replace thermostat.
2. By-pass flame too large.  
Adjust by-pass flame at thermostat.
3. Thermostat set to high.  
Adjust thermostat setting.
4. Incomplete contact of thermostat sensing tube.  
Sensing tube not properly inserted in its tube on the evaporator.
5. Ambient temperature too low.  
Decrease thermostat setting.

## REFRIGERATOR NOT COLD ENOUGH OR NO REFRIGERATION

1. Ventilation not adequate.  
Be sure vents are not obstructed in any manner.
2. Refrigerator not level.  
Refrigerator must be level at evaporator plates.
3. Burner orifice clogged.  
Replace orifice.
4. Improper flame (small).  
Check gas pressure and/or replace orifice, clean flue.
5. By-pass flame too small.

Adjust flame size at thermostat, check flue, check gas pressure.

6. Burner head clogged.

Clean or replace burner head.

7. Improper position of flue baffle.

Clean flue, reposition baffle.

8. Unstable burner flame.

Check gas pressure, clean or replace burner orifice.

9. Inproper food storage.

Rearrange food stuffs.

10. Thermostat set to low.

Raise thermostat setting.

11. Leaky cabinet seals.

Replace seals.

12. Obstructed flue.

Clean flue.

13. Lost thermostat charge.

If flame does not increase in size when end of sensing tube is held in hand, replace thermostat.

14. Failed refrigerating unit.

Replace with new refrigerating unit.

## **ODOR OUTSIDE CABINET**

1. Obstructed flue.

Clean flue.

2. Flame contacts central flue or baffle.

Reposition burner head or reposition baffle.

3. Insufficient primary air.

Burner orifice clogged, replace orifice.

## **ODOR INSIDE CABINET**

1. Infrequent cleaning of food compartment.

Clean food compartment.

2. Refrigerator shut off with door closed.

Refrigerator should be stored with door open.

## **BURNER FLAME GOES OUT**

**NOTE:** Check LP gas tank. Refill if necessary.

1. Orifice clogged.

Replace orifice.

2. Thermocouple tip not in position.

Adjust tip of thermocouple so its tip is in the flame.

3. No contact between thermocouple and safety valve magnet.

The wire between the thermocouple and the safety valve has failed and the thermocouple must be replaced.

4. Faulty safety valve magnet.

Replace magnet.

5. By-pass flame too small.

Adjust flame size at thermostat.

6. Burner head clogged.

Clean or replace burner head.

7. Improper position of flue baffle.

Reposition flue baffle.

## **FROST FORMS TOO RAPIDLY**

1. Dirt in thermostat or valve seat.

Replace thermostat.

2. By-pass flame too large.

Adjust flame size at thermostat.

3. Improper storage of liquid or moist food.

Store these foods in covered containers.

4. Leaky cabinet seal.

Replace seal.

5. Obstructed flue.

Clean flue.

6. Incomplete contact of thermostat sensing tube.

Sensing tube not properly inserted in its tube on the evaporator.

## **BURNER FLAME EXTINGUISHES WHEN THE THERMOSTAT REDUCES**

### **FLAME TO BY-PASS SIZE**

1. Feeler (thermocouple) of flame failure device is located too far from flame.

Bend burner bracket so feeler is closer to flame, so flame failure device does not shut the gas supply off.

2. Retainer holding electromagnet at gas control not tight enough.

Tighten to 5-6 inch lbs.

## **BURNER FAILS TO LIGHT AND LIGHTING PROCEDURE HAS TO BE REPEATED**

1. At first ignition, air may be present in line.

Push ignition button in for a period of one minute to remove air from line and repeat lighting procedure.

2. Plug of ignition device may be too far away from burner head.

Adjust plug in bracket or bend bracket so plug sparks properly.

3. Soot has accumulated on tip of plug.

Remove soot.

4. Short in ignition device.

Repair or replace ignition device.

## **BURNER FLAME BLOWS OUT**

1. Windy conditions.

Place vehicle so wind does not blow directly into vents.

2. Poor sealing around refrigerator.

Seal all gaps between refrigerator and sealing wall, and around control panel and under frame.

# **INSTAMATIC REFRIGERATOR TROUBLE DIAGNOSIS (ELECTRIC)**

## **REFRIGERATOR TOO COLD**

1. Thermostat incorrectly set.

Adjust thermostat setting.

2. Incomplete contact of sensing tube.

Sensing tube not properly inserted in its tube on the evaporator.

3. Ambient temperature too low.

Decrease thermostat setting.

## **REFRIGERATOR NOT COLD ENOUGH**

1. Ventilation not adequate.

Be sure vents are not obstructed in any manner.

2. Refrigerator not level.

Refrigerator must be level at evaporator plates.

3. Heater faulty, wrong voltage or type.

Replace with a unit of the proper voltage and type.

4. Voltage not constant.

Check wiring and voltage source.

5. Heater not inserted correctly in its pocket.

Make sure that the heater is inserted to its full length in its pocket.

6. Improper food storage.

Rearrange foodstuffs to allow for adequate air circulation.

7. Thermostat incorrectly set.

Adjust thermostat setting.

8. Leaky cabinet seals.

Replace cabinet seals.

9. Lost thermostat charge.

Replace thermostat.

10. Failed refrigerating unit.

Replace refrigerating unit.

## **NO REFRIGERATION**

1. Faulty electrical connections.

Repair connections.

2. Refer to Refrigerator Not Cold Enough.

## **FROST FORMS RAPIDLY**

1. Improper storage of liquid and moist foods.

These foods should be stored in covered containers.

2. Leaky cabinet seal(s).

Replace seal.

3. Incomplete contact of sensing tube.

Sensing tube not properly inserted in its tube on the evaporator.

## **ODORS INSIDE CABINET**

1. Infrequent cleaning of food compartment.

Clean food compartment.

2. Refrigerator shut off with door closed.

Refrigerator should be stored with door open.

# **REFRIGERATOR REPLACEMENT**

## **REMOVAL**

1. Shut off LPG at tank.
2. Disconnect battery ground cables.
3. Remove louvered panel at rear of refrigerator.
4. Disconnect 12-volt D.C. leads and LPG line from rear of refrigerator (outside Motor Home).
5. Remove two mounting screws from rear of refrigerator.
6. With the aid of an assistant remove the refrig-

erator from the vehicle and set the unit on a suitable bench.

## **INSTALLATION**

1. Position refrigerator in its opening and secure with two mounting screws at rear of refrigerator.
2. Connect 12-volt D.C. leads and L.P.G. line to rear of refrigerator.
3. Turn on LPG at tank and leak test all connections at refrigerator.

## COMPONENT REMOVAL

### REMOVAL ELECTRIC HEATING ELEMENT

1. Remove louvered vent (outside Motor Home) to gain access to rear of refrigerator.
2. Remove stack cover from burner stack (figure 1).
3. Remove insulation from around heating element.

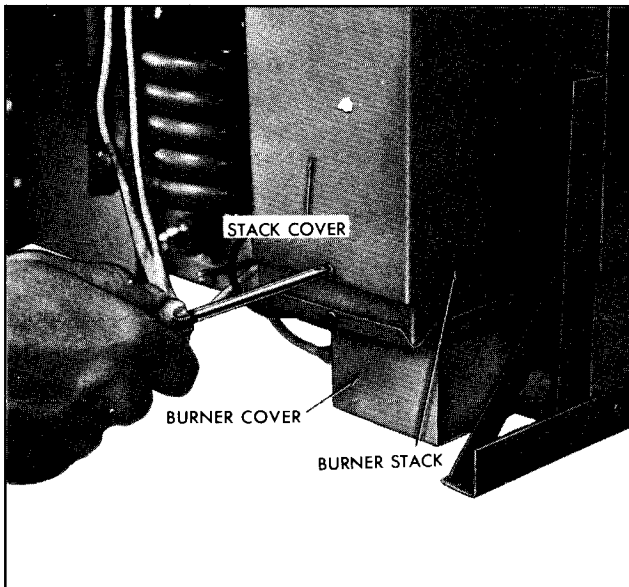

Figure 1—Removing Plate on Burner Stack

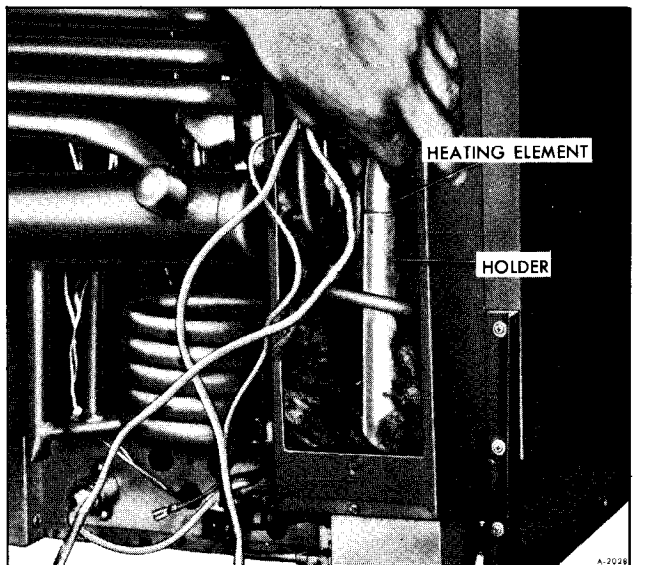

Figure 2—Removing Heating Element

4. Disconnect electrical leads.
5. Pull heating element out of holder (figure 2).

### REMOVING IGNITION PLUG

1. At rear of refrigerator, remove burner cover (figure 1) by removing two screws and sliding it out of position.
2. Remove two screws on retaining bracket and remove ignition plug from burner housing (figure 3).
3. Cut insulation around ignition plug and remove it.
4. Remove ignition plug from wire by rotating it counter clockwise.

### THERMOCOUPLE REMOVAL

1. Remove burner cover by removing two screws and sliding it out of position.
2. Remove retaining nuts at end of thermocouple and remove tip from burner box (figure 4).
3. Remove thermocouple lead from electromagnet as shown in Figure 5.
4. Remove thermocouple assembly from control pan.

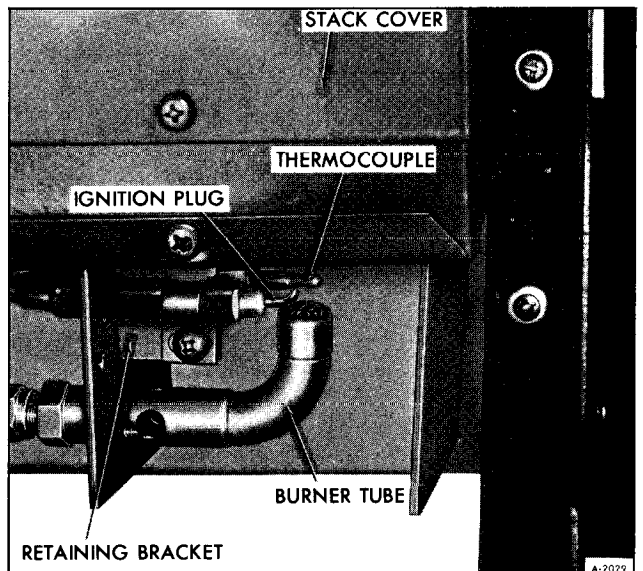

Figure 3—Burner Cover Removed

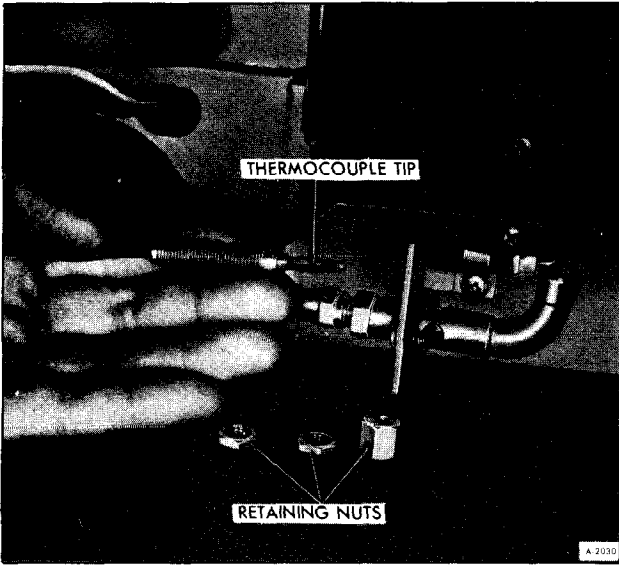

Figure 4—Thermocouple Removed From Burner Box

## BURNER TUBE REMOVAL (FIGURE 6)

1. Turn off LPG at storage tank.
2. Remove gas line from burner orifice fitting.

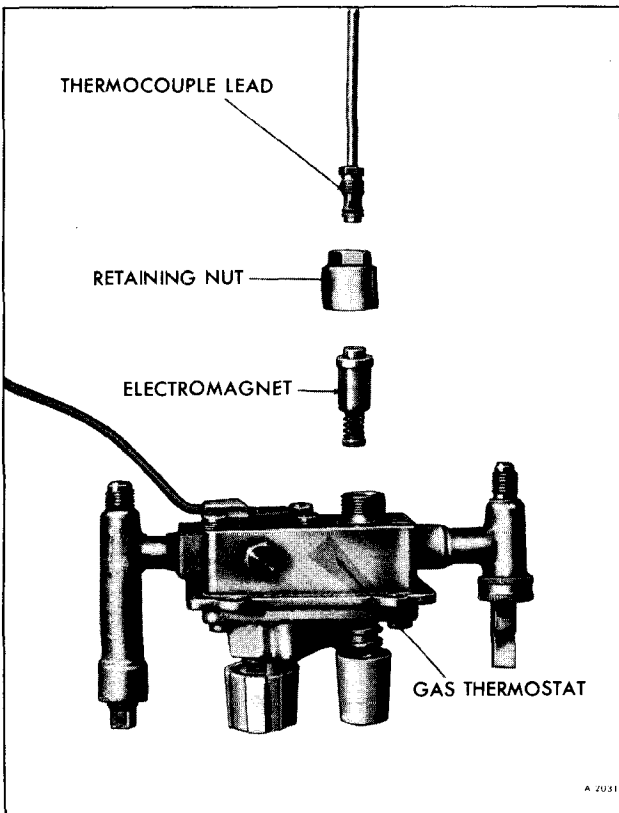

Figure 5—Thermocouple Lead and Electromagnet

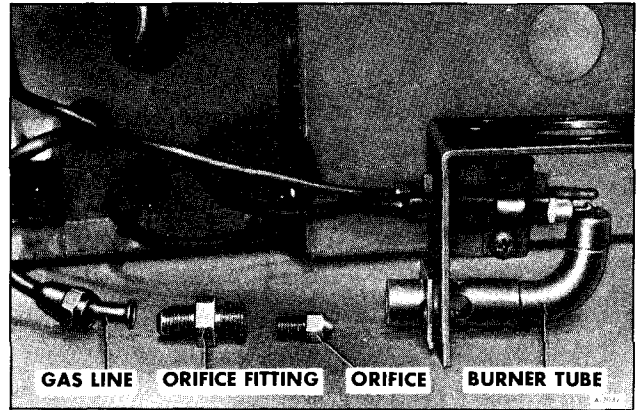

Figure 6—Burner Assembly

3. Remove two retaining screws from burner tube mounting bracket and remove burner tube.
4. Remove orifice fitting and burner orifice from burner tube.

## BURNER ORIFICE REMOVAL (FIGURE 6)

1. Turn off LPG at storage tank.
2. Remove gas line from orifice fitting.
3. Remove orifice and orifice fitting, from burner tube.
4. Remove orifice from orifice fitting.

## GAS THERMOSTAT REMOVAL

1. Turn off LPG at storage tank.
2. Pull control pan forward.
3. Remove thermostat sensing tube from its holder at evaporator plate.
4. At back of refrigerator remove cork plug which seals hole where sensing tube protrudes and pull tube through hole.
5. Remove thermocouple lead from thermostat (figure 5).
6. Remove control knobs for both gas and electric thermostats.
7. Remove control face plate.
8. Remove all gas lines to thermostat.

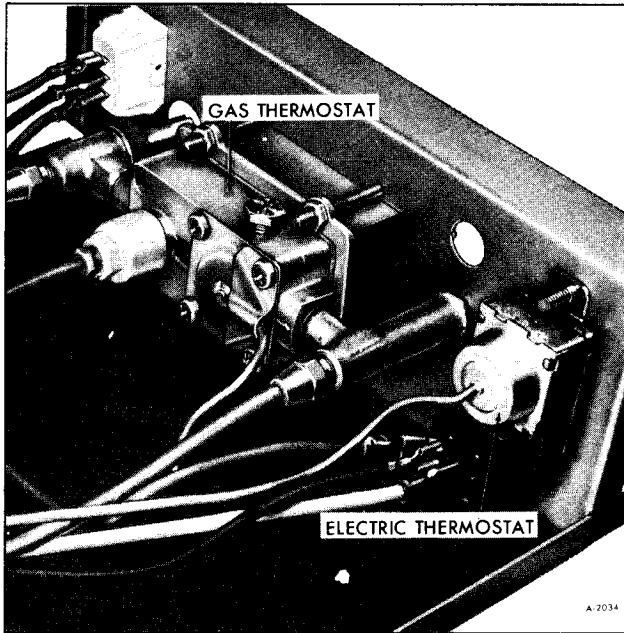

Figure 7—Thermostats

9. Remove four nuts and bolts retaining gas thermostat to control pan, and remove thermostat (figure 7).

## ELECTRIC THERMOSTAT REMOVAL (FIGURE 7)

1. Pull control pan forward.
2. Remove sensing tube from holder on evaporator plate.

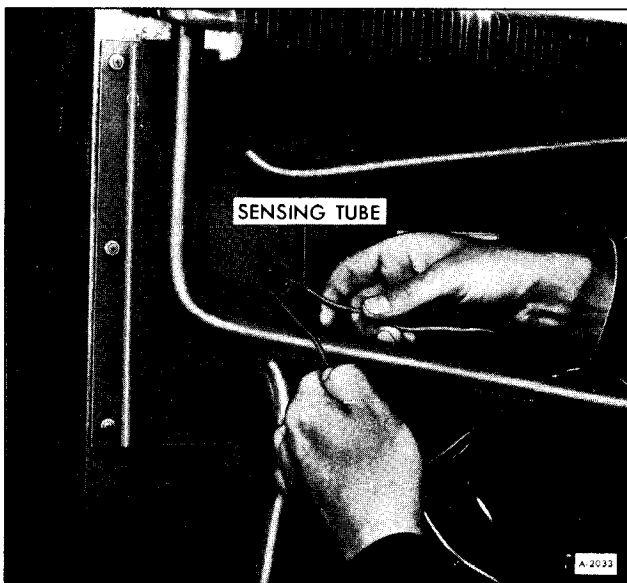

Figure 8—Removing Thermostat Sensing Element

3. At back of refrigerator remove cork plug which seals hole where sensing tube comes through, and pull tube through hole (figure 8).

4. Remove electrical leads from thermostat.
5. Remove control knobs, and control face plate.
6. Remove two retaining screws and remove thermostat.

## CONTROL PAN REMOVAL

1. Remove louvered vent (outside Motor Home) to gain access to rear of refrigerator.

2. Turn off LPG at storage tank, and disconnect battery ground cables.

3. Disconnect LPG supply at back of refrigerator.

4. Disconnect 12-volt D.C. leads.

5. Remove four screws from rear of control pan. Refer to Figure 9.

6. Remove kickplate at front of refrigerator to gain access to controls.

7. Remove four screws from front of control pan.

8. Slide control pan out as shown in Figure 10.

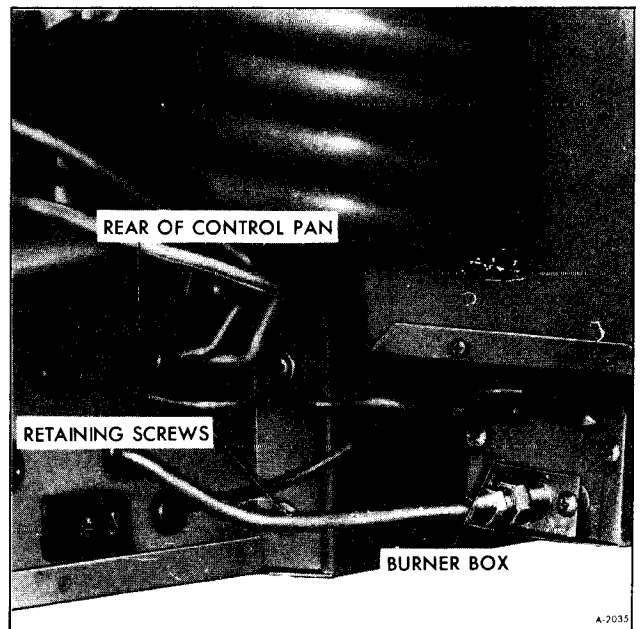

Figure 9—Control Pan (Rear)



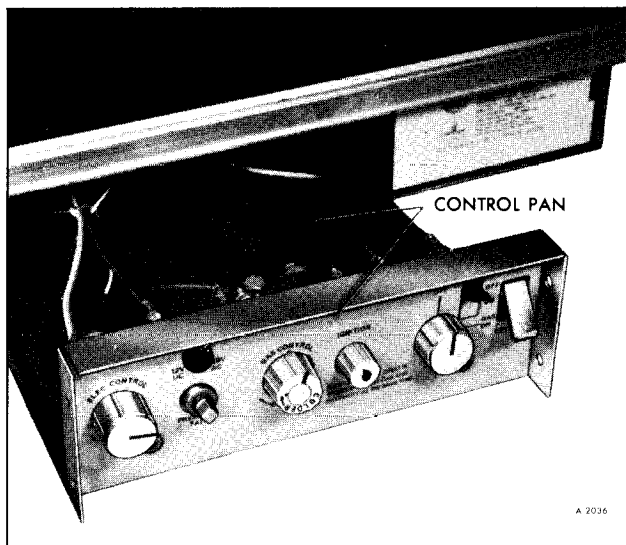

Figure 10—Control Pan (Front)

**NOTE:** Removal of control pan to this point, will allow servicing or replacement to be performed on controls.

## COOLING UNIT REMOVAL

1. Remove refrigerator from Motor Home.
2. Remove drip pan under freezer.
3. Remove trim plate from secondary evaporator under freezer.
4. Remove five screws retaining primary evaporator to freezer compartment.

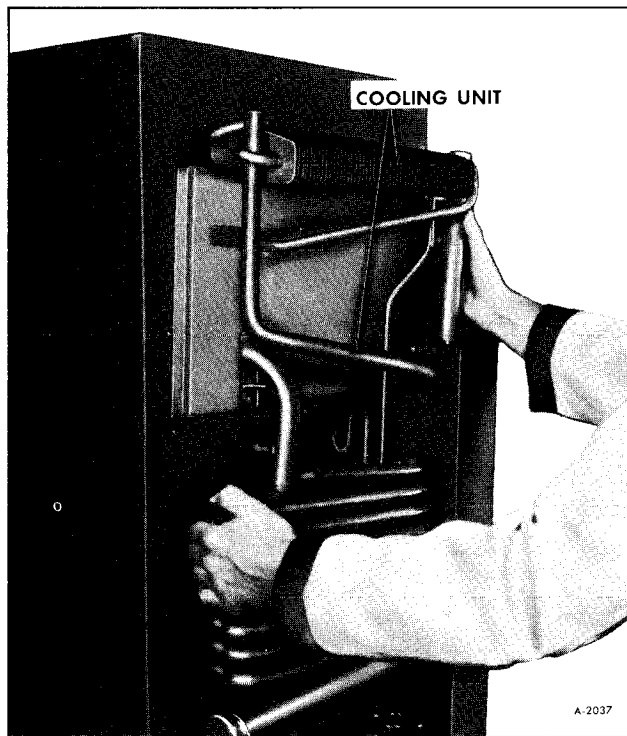

Figure 11—Removing Cooling Unit

5. Disconnect electrical leads to electric heating element.
6. Disconnect thermostat sensing tubes and pull them through back of refrigerator.
7. Disconnect burner box from flue.
8. Remove nine screws retaining cooling unit to back of refrigerator, and remove cooling unit (figure 11).

## CLEANING AND INSPECTION

### GAS LINE

LP gas is highly inflammable and it is of extreme importance to ensure not only that all joints in piping carrying the gas from the storage tank to the appliances are and will remain absolutely gas tight, but that any non-metallic packings used in such joints are made from materials that will not deteriorate from contact with LP gas.

The gas line should be free of kinks and sharp ends.

Periodically, the gas should be turned on, and all joints in the gas line must be checked for leaks up to the burner by use of soap and water solution.

### BURNER ORIFICE CLOGGED

When the burner orifice is clogged, the flame will become too small on the maximum setting of the thermostat which may affect the burner heating output and result in decrease of cooling efficiency. For taking out the clog or replacing the burner orifice, first remove flared connector, then the orifice. The burner is easily reached from the rear of refrigerator. Refer to Figure 6.

### LOST THERMOSTAT CHARGE

If the thermostat control assembly loses its charge, it will become inactive.

Make a lost charge test in case the flame stays minimum despite the proper setting up of the thermostat.

Proceed as follows for the test:

Remove the sensing tube from the sleeve at the evaporator. Warm up the free end of the capillary tube by holding it with the palm of the hand. If the flame fails to magnify in size, the thermostat has lost its charge and the thermostat must be replaced.

## COOLING UNIT

If an excessive vaporizing of the ammonia within the boiler occurs due to improper heat input, unlevel operation or inadequate ventilation. The liquid mixture in the boiler becomes very weak and the pump will cease to operate, which means that the circulation of liquid stops with the result that the evaporator inside the cabinet ceases to produce cooling.

Such a blockage of the unit in the liquid circuit is most usually made evident by signs of overheating on the vapor pipe leading from the boiler to the condenser, the paint on this pipe being blistered and the metal becoming discolored. This condition can only be corrected by replacing the cooling unit.

The temperatures on various parts of a unit vary continuously when it is operating on thermostatic control and it is impossible to base a judgement on the symptoms given unless the refrigerator has been operating continuously on fully correct heat input for at least five hours, and preferably 12 hours, prior to examination. In many cases, this can be arranged by a telephone call to the customer, asking him to switch the thermostat to "coldest" on the day before the inspection call. If after 12 hours operation on "coldest" the performance is satisfactory, the unit is not at fault unless the complaint is one of varying or intermittent performance. In this connection, the room temperature at the time of the complaint must be considered, as a unit which is satisfactory at an ambient temperature of 50°F may not be satisfactory at 95°F.

In cases where satisfactory performance is obtained on "coldest" but not on other settings, the thermostat is to be suspected.

When a normal unit is working on "coldest" the absorber coil will be warmer at the bottom than at the top. The absorber vessel will be warmer. The vapor cooling pipe from the boiler to the condenser will be warm, bearable to the hand, at the bend where it joins the condenser, with a gradual rise in temperature towards the boiler.

## LEAKS

Unsatisfactory unit performance due to an ammonia leak can be determined in the case of a visible leak by traces of a yellow deposit at the point where the ammonia is bleeding. If there is a leak on the evaporator inside the cabinet, ammonia smell may result.

## HEATING ELEMENT (FIGURE 12)

The heating element can be tested with an ohmmeter. Disconnect the 12-volt D.C. leads to the heating element. Connect an ohmmeter across these two leads a reading of .5 to .65 ohms should be obtained. If not the element has a short or open and must be replaced.

## FLUE TUBE

Once a year the flue tube should be cleaned as follows:

1. Remove refrigerator from Motor Home.
2. Place a clean cloth over burner head.
3. Remove flue baffle.
4. Using a stiff brush, such as one used to clean shotguns, clean the full length of the flue tube.

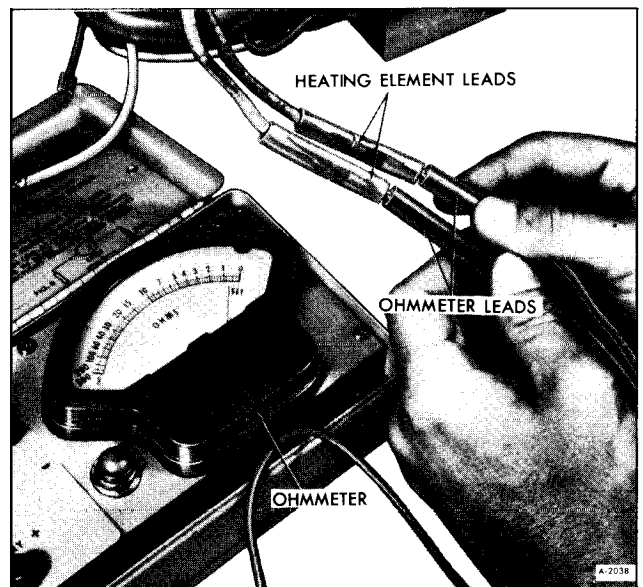

Figure 12—Testing Electric Heating Element

## COMPONENT INSTALLATION

### HEATING ELEMENT INSTALLATION

1. Place heating element in holder (figure 2).
2. Connect 12-volt D.C. leads.
3. Repack insulation in burner stack and install cover.
4. Install vent on exterior of Motor Home.

### INSTALLATION IGNITION PLUG

1. Screw ignition plug into wire by rotating it clockwise.
2. Place new shrink tube over ignition plug and position as shown in Figure 13.
3. Heat shrink tube, made of thermosetting resin, uniformly with a lighter or match until a good fit is obtained (figure 14).

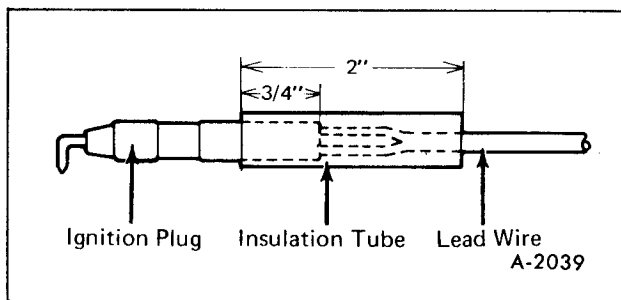

Figure 13—Fitting Shrink Tube on Ignition Plug

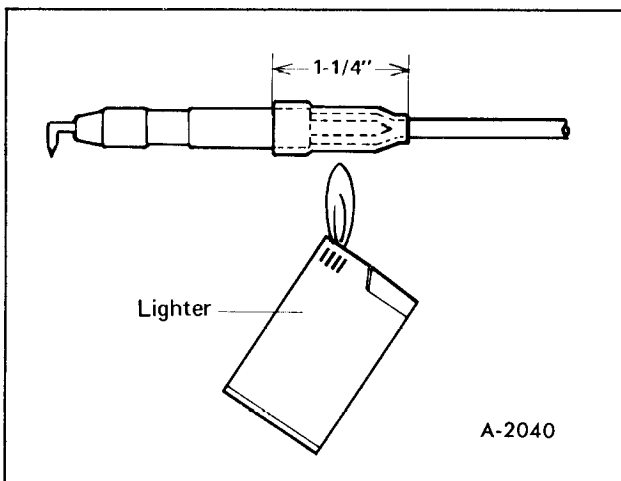

Figure 14—Heating Shrink Tube

### THERMOCOUPLE INSTALLATION

1. Position thermocouple and lead in control pan.
2. Install thermocouple lead in electromagnet and torque nut to 5-6 inch lbs. (figure 5).
3. Install thermocouple tip in burner box and secure with retaining nuts. Be sure tip is positioned so it will still contact flame when burner is operating on by-pass flame.
4. Install burner cover and secure with two screws.

### BURNER TUBE INSTALLATION (FIGURE 6)

1. Install burner orifice and orifice fitting in burner tube.
2. Install burner tube and secure with two retaining screws through bracket. Check position of ignition plug and thermocouple.
3. Install gas line to orifice fitting.
4. Turn on LPG gas and leak test all fittings.

### BURNER ORIFICE INSTALLATION (FIGURE 6)

1. Install orifice in orifice fitting.
2. Install orifice and orifice fitting in burner tube.
3. Install gas line to orifice fitting.
4. Turn on LP gas at tank and leak test all fittings.

### GAS THERMOSTAT INSTALLATION

1. Position thermostat in control pan, and secure with four nuts and bolts.
2. Connect all gas lines to thermostat.
3. Install control face plate and control knobs to front of control pan.

4. Install thermocouple lead to back of thermostat and torque nut to 5-6 in. lbs.

5. Run thermostat sensing tube through back of control pan and through hole at back of refrigerator.

6. Position end of sensing tube in its holder at evaporator plate.

7. Turn on LP gas at storage tank and leak test all fittings.

8. Position control pan in refrigerator and secure with retaining screws.

## ELECTRIC THERMOSTAT INSTALLATION

1. Position thermostat and secure with two screws.

2. Install face plate and control knobs to front of control pan.

3. Connect electrical leads.

4. Run sensing tube through back of control pan, and through hole in back of refrigerator and seal hole with cork plug.

5. Position end of sensing tube in its holder at evaporator plate.

6. Position control pan in refrigerator and secure with retaining screws.

## CONTROL PAN INSTALLATION (FIGURE 10)

1. Position control pan under refrigerator.

2. Secure at front with four retaining screws.

3. Install kickplate.

4. Secure at rear with four retaining screws.

5. Connect LP gas line to back of refrigerator.

6. Connect 12-volt D.C. leads to terminal block at back of refrigerator.

7. Turn on LP gas at storage tank and leak test all fittings.

8. Connect battery ground cables.

## COOLING UNIT INSTALLATION

1. Position cooling unit on back of refrigerator and secure with nine screws (figure 11).

2. Connect burner box on bottom of flue.

3. Install thermostat sensing tubes, and connect leads to electric heating element.

4. Secure primary evaporator to freezer compartment with five retaining screws.

5. Install trim plate on secondary evaporator.

6. Install drip pan under freezer.

7. Install refrigerator in Motor Home.

## ON VEHICLE ADJUSTMENTS

### BURNER TUBE

The burner tube should be positioned in such a way that its center line should be aligned center to center with the flue tube (See figure 15).

This can be accomplished by bending burner box until proper position is obtained.

are two adjustment screws. The lower adjustment screw controls the gas pressure to the burner. This adjustment should remain open since gas pressure is regulated at the regulator on the gas tank.

### LOW FLAME

The upper adjustment screw adjusts the flame size when gas control is on by-pass. This may be adjusted while on by-pass flame. **DO NOT REMOVE THE COLD CONTROL KNOB.**

### GAS THERMOSTAT (FIGURE 16)

Immediately to the right of the cold control knob

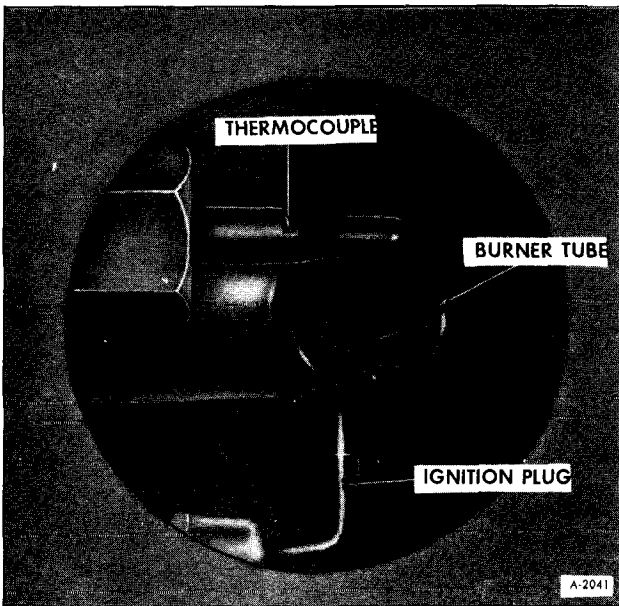

Figure 15—Proper Burner, Ignition Plug, and Thermocouple Placement

The ignition tip should be positioned as shown in Figure 15, so that the spark will arc to the screening on top of the burner tube.

### THERMOCOUPLE TIP POSITION (FIGURE 15)

The tip of the thermocouple must be placed so that its tip is in the flame while the burner is operating on a by-pass flame. If its tip is not in the flame the automatic flame failure device will sense that there is no flame and shut off the gas supply.

The thermocouple position can be adjusted by bending its mount on the burner box (figure 17).

**WARNING: BE SURE REFRIGERATOR IS TURNED OFF AND COMPONENTS HAVE BEEN ALLOWED TO COOL PRIOR TO ADJUSTMENT OF THERMOCOUPLE TIP. THIS IS TO PREVENT BURNING OF FINGERS DURING ADJUSTMENT.**

### THERMOSTAT SENSING TUBE

At the bottom of the freezing compartment is a sleeve in which the end of the thermostat sensing tube must be inserted. If the sensing tube is not properly inserted in its sleeve, the burner will operate continuously at maximum flame. It will cause too low cabinet temperatures.

### IGNITION DEVICE

If when pushing ignition button connected with the ignition device, LP gas is not ignited despite proper sparking, adjust the ignition tip.

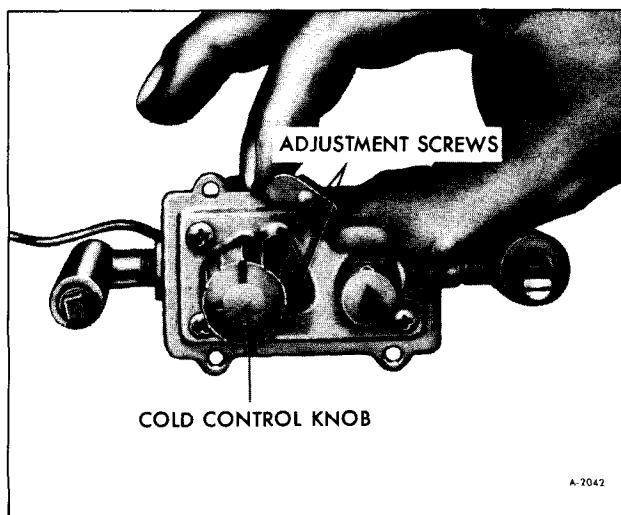

Figure 16—Thermostat Adjustment

### LP GAS PRESSURE

The pressure of the LP gas may be measured at the pressure tap on the control panel on the refrigerator. A monometer or low pressure gauge should be used.

The pressure of the burner should be checked at the time the refrigerator is started up. After connecting the pressure gauge, set the thermostat dial at "coldest".

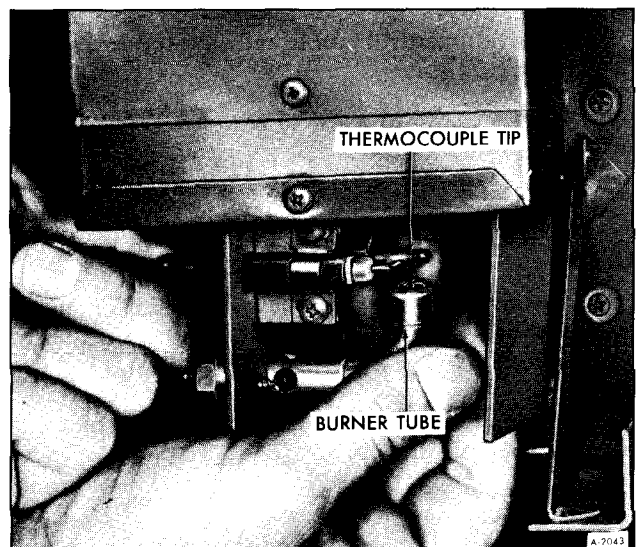

Figure 17—Thermocouple Adjustment

Turn on the gas and light the burner. At the "coldest" setting the pressure reading should be at a minimum 10 1/2" or a maximum of 11 1/4" as the LP gas is supplied directly to the refrigerator from the regulator on the gas tank at pressure of 11".

## LEVELING

In the boiler of the cooling unit, ammonia vapor is distilled from an ammonia-water mixture and carried to the finned condenser where it liquefies. The liquid flows to the evaporator inside the cabinet where it cools, evaporating into a circulating flow of hydrogen gas. If the evaporator is not level, the liquid readily accumulates, forming pockets which can impair the gas circulation or block it completely, resulting in suspension of cooling action.

When the vehicle is stationary, it must be leveled to be comfortable to live in. If the refrigerator is properly installed, i.e. the ice tray compartment shelf is parallel with the floor, the refrigerator will operate properly. To check this, a bubble level should be used. With the level placed on the ice tray compartment shelf, check the position of the bubble (if necessary, with the aid of a small mirror).

Adjust the position of the vehicle so that the bubble is in the center ring of the level.

When the vehicle is moving, the continuous rolling and pitching movement will not affect the refrigerator as long as the movement passes either side of level but when the vehicle is temporarily parked, the sensitivity of the refrigerator should be kept in mind.

## DOOR SEAL

It is essential, for correct operation, that the door gasket make a good seal all around, against the front of the cabinet.

The gasket should just contact the front of the cabinet when the door is closed. This is normally allowed for during manufacturing.

Failure of the door gasket to contact the front of the cabinet can be determined visually when the door is closed. Run a piece of thin cardboard along the door seal, inserted between the gasket and the cabinet front.

Nowhere should the card feel loose. Improper door sealing on cabinets provided with magnetic door gasket can be corrected by slackening the upper and lower hinge fixing screws and moving the door inwards or outwards by inserting a washer or taking away to correct the door as required until a satisfactory seal is obtained. If a good seal cannot be obtained, a new gasket should be installed.



# SECTION 24E

## ROOF MOUNTED AIR CONDITIONER

Information for servicing the roof mounted air conditioner was not available at time of printing.



# SECTION 24F LP GAS SYSTEM

The contents of this section are listed below:

SUBJECT	PAGE NO.
Description.....	24F-1
Trouble Diagnosis .....	24F-2
On-Vehicle Adjustment .....	24F-3
Regulator .....	24F-3
Component Replacement .....	24F-4
Fill Valve .....	24F-4
Liquid Level Outage Valve .....	24F-5
Vapor POL Valve .....	24F-5
Regulator .....	24F-5
Gas Tank Sight Valve Dial.....	24F-5
Gas Tank Float Assembly.....	24F-6
LP Gas Tank .....	24F-6
LP Gas Lines and Fittings .....	24F-6

**WARNING: EMPTYING THE LP GAS TANK SHOULD BE DONE BY AN AUTHORIZED LP GAS DEALER.**

**IMPORTANT:** The LP Gas System will not operate correctly if the tank is overfilled. An overfilled tank will not allow proper vapor pressure to develop and the entire system will cycle between near normal pressure (11 inches of water pressure) and a much lower pressure which will not allow the appliances to operate.

## DESCRIPTION

The LP (liquid petroleum) gas system supplies fuel for the vehicles range/oven, furnace and optional gas/electric refrigerator as shown in Figure 1. The LP gas tank, which stores the fuel, is located in its compartment at the right rear of the vehicle. The standard tank is 30" long and holds 44.5 lbs of LP gas and the optional 40" tank holds 65 lbs. The tank

is equipped with a fill valve, liquid level outage valve, vapor POL valve, tank float gauge assembly and a regulator.

The copper gas lines on both model Motor Homes are laid out so that most connections are outside the vehicle. The lines go inside the vehicle only to reach an appliance.



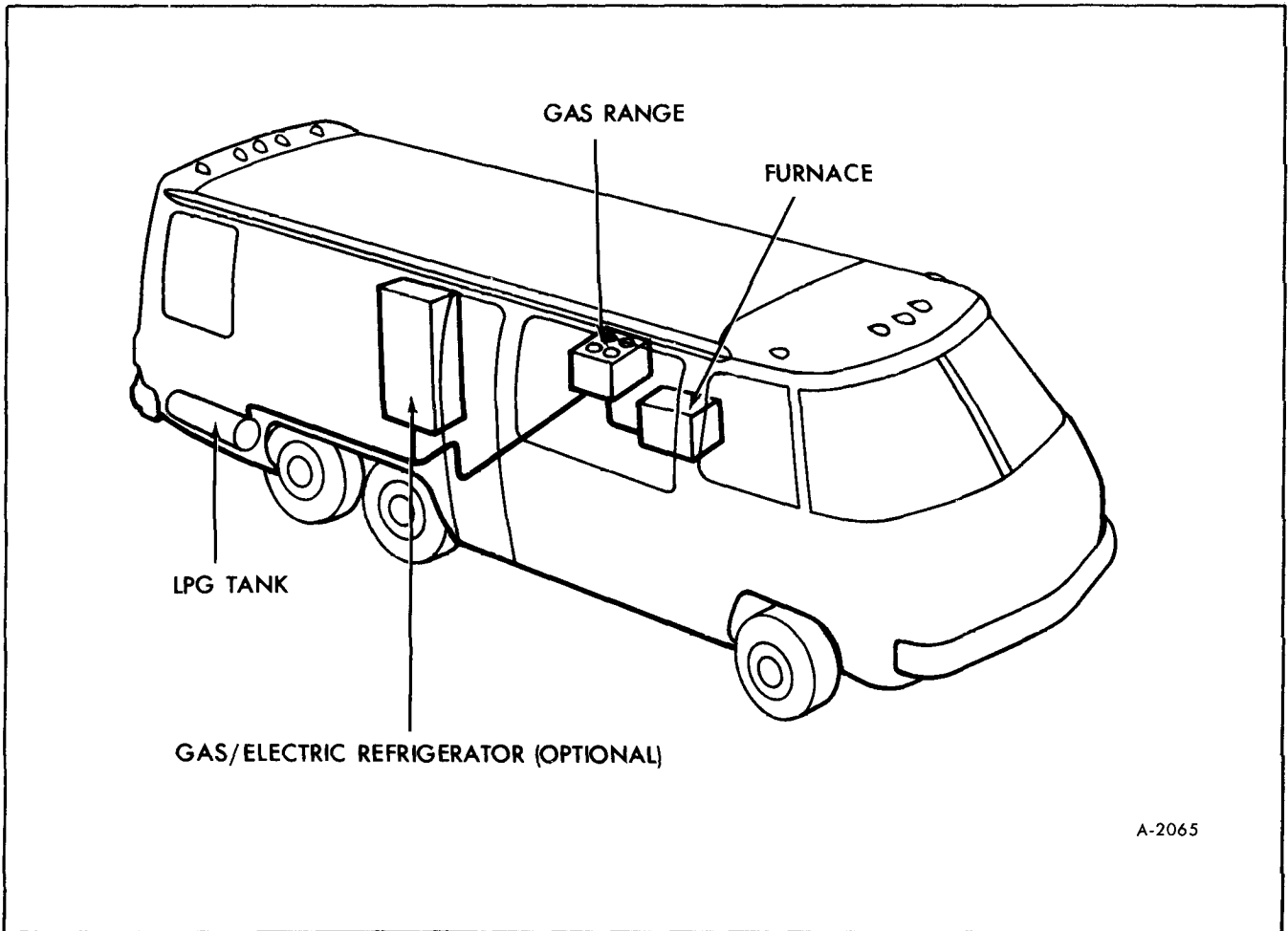

A-2065

Figure 1-LP Gas System (Model 260 Shown)

## TROUBLE DIAGNOSIS

Problem	Possible Cause	Correction
Gas appliances won't operate.	Appliance faulty	Refer to "TROUBLE DIAGNOSIS" in the particular section for correction.
Insufficient gas supply	Vapor POL valve not open completely. Regulator out of adjustment  Leak in LP gas system.	Open valve completely. Refer to "ON VEHICLE ADJUSTMENTS" for regulator pressure specifications. Make up a soap solution. Apply to all fittings. If bubbles occur a leak is present. Inspect fitting for damage or cracks. Replace fitting if necessary. Use only A.G.A. (American Gas Approved) fittings. Otherwise tighten fitting.

Problem	Possible Cause	Correction
	<p>LP gas tank has been over-filled and regulator has frozen up.</p> <p>In freezing weather, water in the system may freeze and block regulator or lines.</p>	<p>Empty LP gas tank. Refer to "LP GAS TANK-REMOVAL" later in this section for proper procedure of emptying tank. Refill tank correctly, see "WARNING" at beginning of this section.</p> <p>In freezing weather add 1 pint of suitable tank and gas line anti-freeze. Then using a monometer check regulator. Refer to "ON-VEHICLE ADJUSTMENTS" later in this section.</p> <p>Empty LP gas tank. Refer to "LP GAS TANK-REMOVAL" later in this section for proper emptying and removal of the tank.</p> <p>Flush out tank with a suitable gas system anti-freeze. Add 1 pint of same anti-freeze to tank and fill with LP gas.</p>
<p>Leaking fill valve assembly or liquid level outage valve.</p>	<p>Damaged or dirt in mechanism.</p>	<p>Replace valve or valve seat. Refer to specific subjects later in this section.</p>
<p>Gas tank is known to be full, however, the tank sight valve does not indicate full.</p>	<p>Damaged float or sight valve.</p>	<p>Replace float and/or sight valve as described later in this section.</p>

## ON-VEHICLE ADJUSTMENT

### REGULATOR

The regulator shown in Figure 2 is adjustable and is set at the factory to deliver LP gas at a rate of eleven inches of water pressure as measured on a monometer.

### ADJUSTMENT

**WARNING: FAILURE TO PERFORM REGULATOR ADJUSTMENT ACCURATELY COULD RESULT IN IMPROPER OPERATION OF LP GAS APPLIANCES WITHIN MOTOR HOME AND BE A HEALTH AND SAFETY HAZARD TO OCCUPANTS OF VEHICLE.**

1. Connect a monometer to a range spud exposed after removing a burner from the range.

2. Turn on the corresponding burner valve all the way. If the dial does not read eleven inches of water pressure, the regulator needs adjusting.

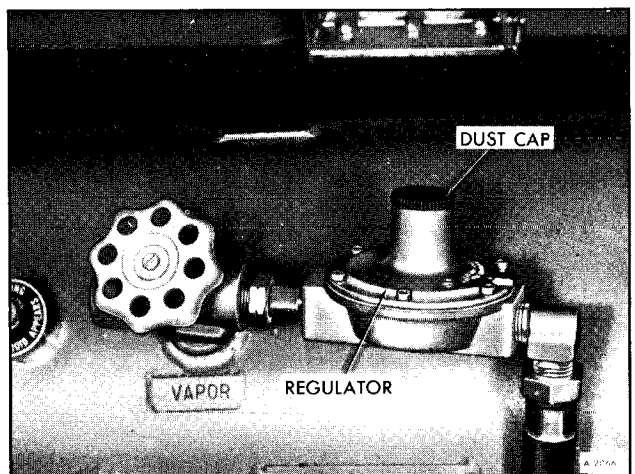

Figure 2-Regulator

3. Remove the dust cap from the top of the regulator (See figure 2).

4. Turn the adjusting slot clockwise to increase the pressure and counter-clockwise to decrease the pressure (See figure 3).

5. If the correct adjustment can't be made or if the monometer level fluctuates the regulator is defective and needs to be replaced. See "REMOVAL" later in this section.

## LEAK TEST

Any fitting or valve suspected of leaking may be tested by applying a soap solution. Bubbles will appear wherever a leak occurs. Tighten fittings or replace components, as necessary.

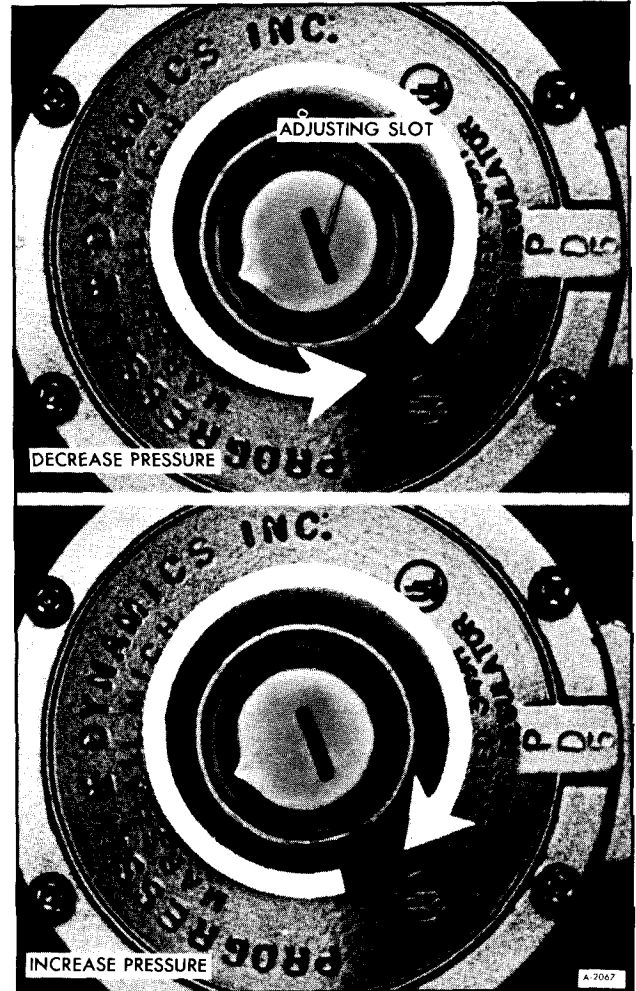

Figure 3-Regulator Adjustment

## COMPONENT REPLACEMENT

### FILL VALVE (FIGURE 4)

#### REMOVAL

1. Empty tank. Refer to WARNING at the beginning of this section.
2. Remove the fill valve cap.
3. Remove the fill valve.

#### INSTALLATION

1. Wrap threads with teflon tape and install valve into tank.

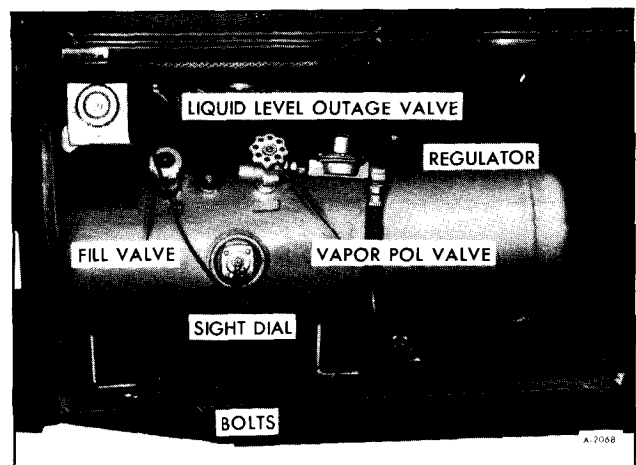

Figure 4-LP Gas Tank Valves

2. Tighten all fittings securely.
3. Fill tank.

## LIQUID LEVEL OUTAGE VALVE

### REMOVAL (FIGURE 4)

1. Empty tank. Refer to **WARNING** at the beginning of this section.
2. Remove outage valve.
3. Inspect valve seat.
4. If valve seat is defective replace with a new valve.

### INSTALLATION

1. Position stop fill dial over adapter and thread valve into adapter. Tighten with fingers.
2. Fill tank.

## VAPOR POL VALVE (FIGURE 4)

### REMOVAL

1. Empty tank. Refer to **WARNING** at beginning of this section.
2. Remove valve handle securing screw. Remove handle (See figure 6).
3. Remove valve stem (See figure 6).
4. Inspect seals. Replace stem if necessary.

### INSTALLATION

1. Install valve stem. Tighten securely.
2. Replace handle and securing screw.
3. Fill tank.

## REGULATOR

The regulator is adjustable. Refer to "On-Vehicle Adjustment-Regulator" earlier in this section.

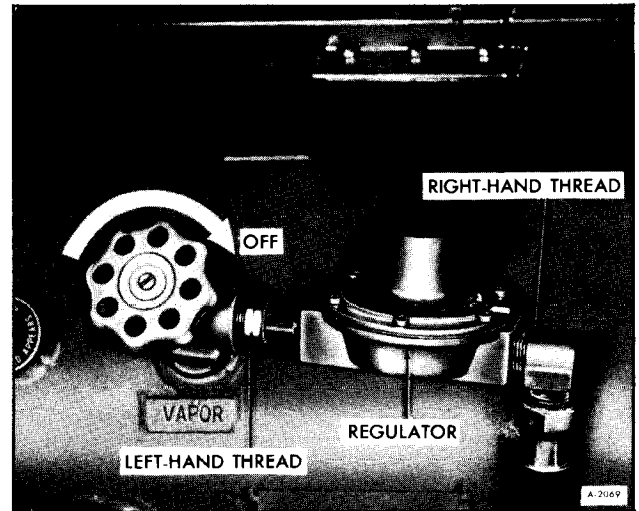

Figure 5-Regulator Attachment

### REMOVAL

1. Turn off gas at the tank (See figure 5).
2. Remove hose assembly from regulator.
3. Remove regulator from POL valve.

**IMPORTANT:** The connector attaching the regulator to the vapor POL valve is left-hand threaded (See figure 5).

### INSTALLATION

1. Install regulator to POL valve.
2. Connect hose assembly to regulator. Use teflon tape on threads.
3. Position regulator as shown in Figure 5 and tighten all fittings securely.

## GAS TANK SIGHT VALVE DIAL

### REMOVAL

1. Remove two (2) retaining screws (See figure 6).
2. Remove wire retaining screw and wire, if so equipped.
3. Remove sight dial.

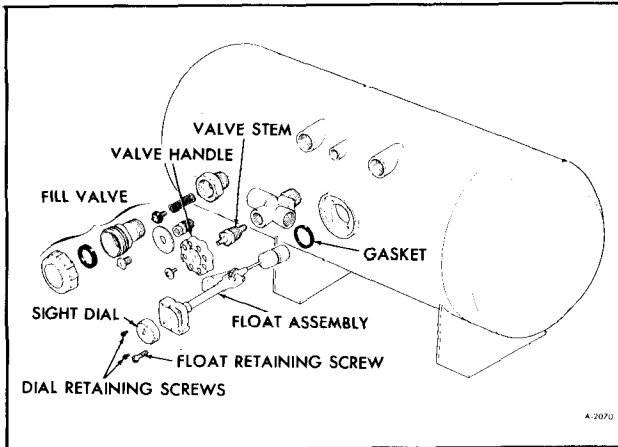

Figure 6—LP Gas Tank Components

## INSTALLATION

1. Install sight dial.
2. Install two (2) dial retaining screws.
3. Install wire and retainer screw if removed.

## GAS TANK FLOAT ASSEMBLY

### REMOVAL

1. Empty tank. Refer to **WARNING** at beginning of this section.
2. Remove four (4) float retaining screws (See figure 6).
3. Disconnect wire at sight dial, if equipped.
4. Remove float assembly.

**NOTE:** Position float as shown in Figure 6 while removing from tank.

### INSTALLATION

1. Install float assembly.
2. Install and tighten four (4) retaining screws.

3. Connect wire to sight dial, if equipped.
4. Fill tank.

## LP GAS TANK

When filling the tank refer to **IMPORTANT** at beginning of this section.

### REMOVAL

1. Empty tank. Refer to **WARNING** at beginning of this section.
2. Disconnect hose assembly from regulator and position out of the way.
3. Remove four (4) nuts and bolts securing tank to vehicle (See figure 4).
4. Disconnect wire from sight dial, if equipped.
5. Remove tank.

### INSTALLATION

1. Install tank and four (4) bolt and nut assemblies. Torque nuts to 30 ft. lbs.
2. Connect wire to sight dial, if removed.
3. Apply teflon tape to threads and connect hose assembly to regulator.
4. Fill tank.

## LP GAS LINES AND FITTINGS (FIGURE 7)

LP gas lines are standard copper tubing connected with AGA (American Gas Association) fittings. The lines are replaceable or repairable. A damaged portion of the line may be cut out and union's used to connect a new section of tube to the line. Be sure that gas is turned off at the tank. Remember there may always be some residual gas in the system that will escape when a fitting is loosened, therefore work in a well ventilated area.

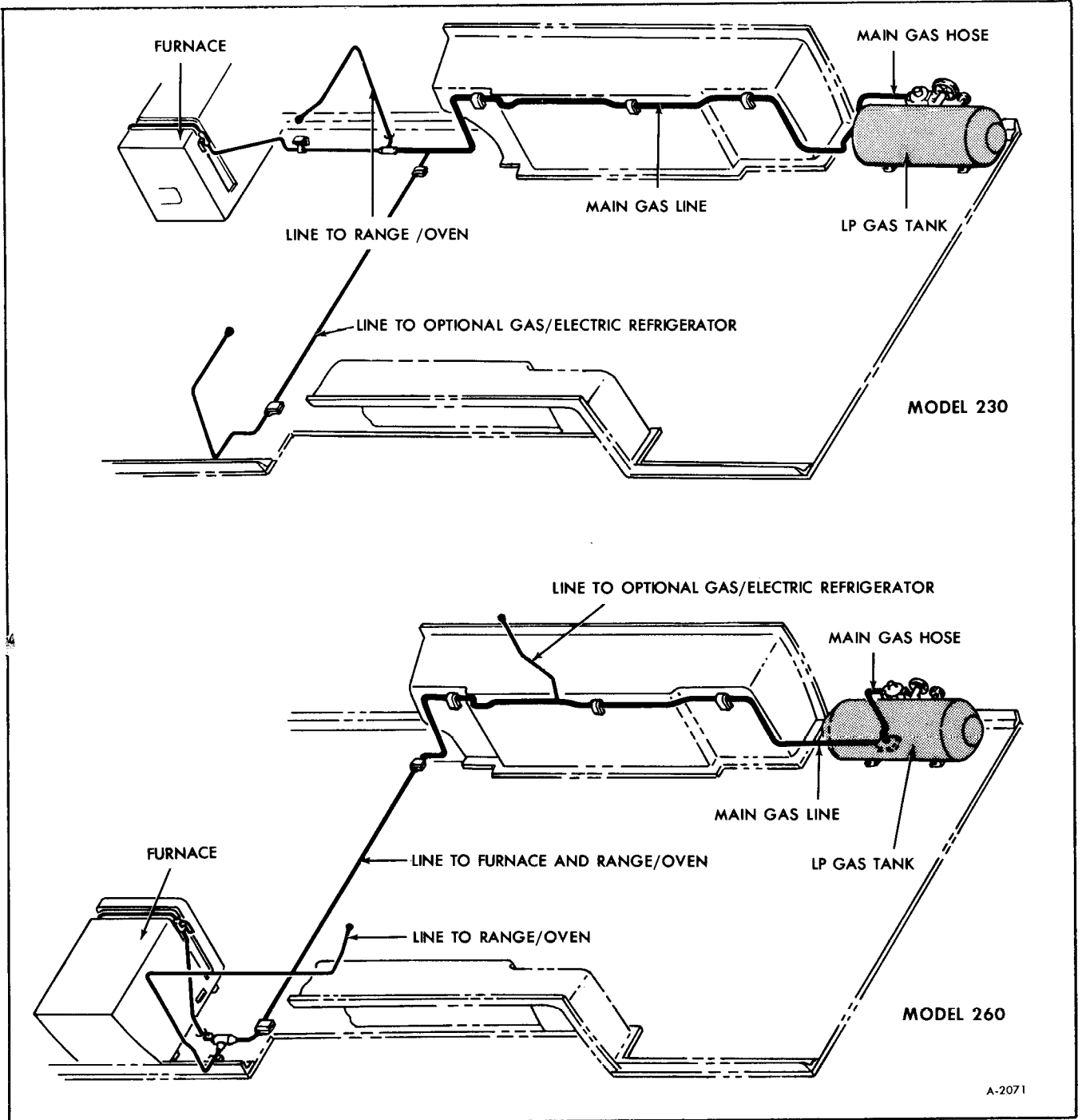

A-2071

Figure 7-LP Gas Lines

# SECTION 24G

## FURNACE

Contents of this section are listed below:

SUBJECT	PAGE NO.
General Information .....	24G- 2
Furnace Trouble Diagnosis .....	24G- 5
Combustion Chamber Replacement .....	24G-10
Component Repair.....	24G-12
On Vehicle Adjustments .....	24G-25

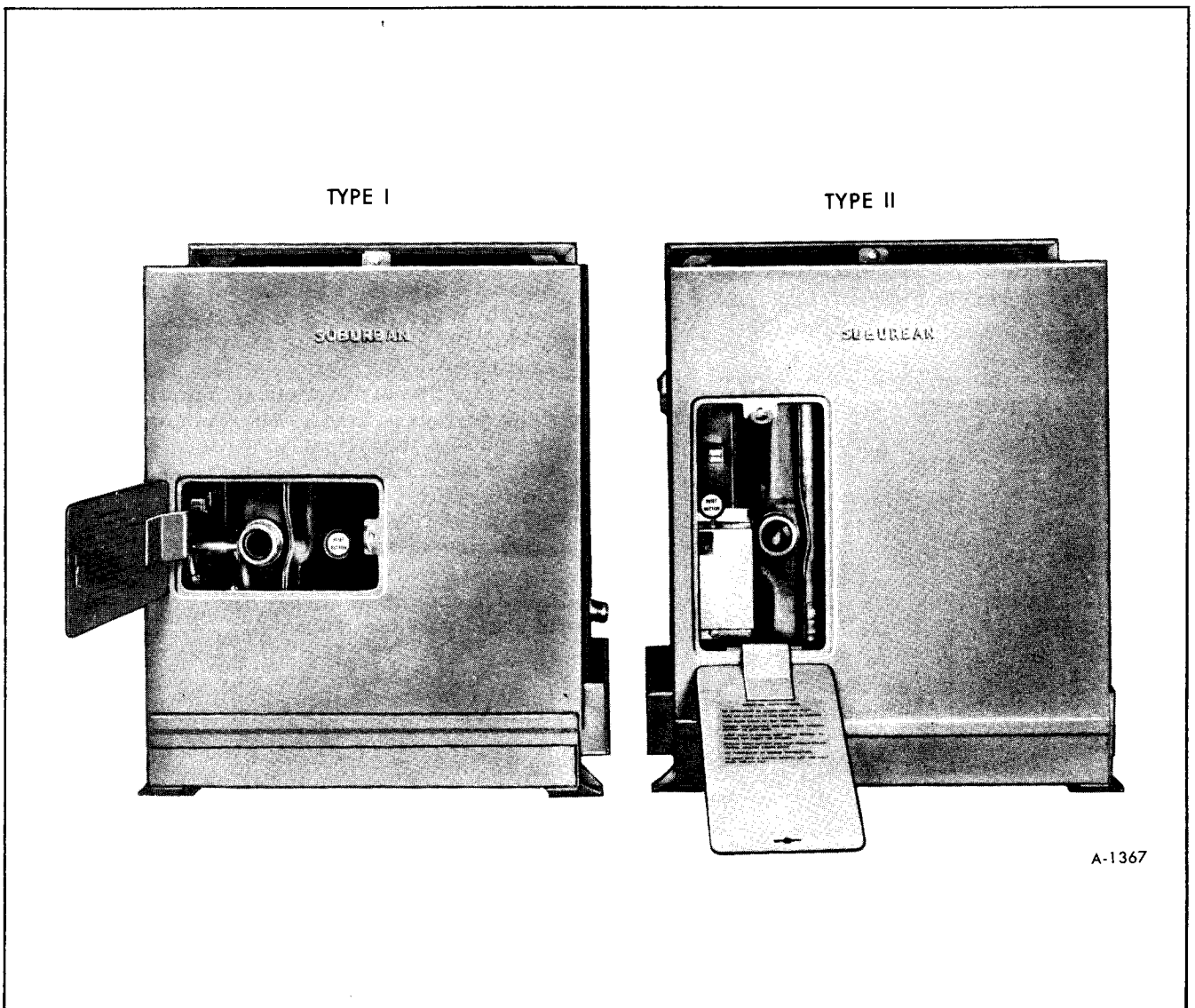

Figure 1—Type I and II Furnaces

## GENERAL INFORMATION

**WARNING: BEFORE ANY REMOVAL OR DISASSEMBLY PROCEDURES ARE PERFORMED ON THE FURNACE, BE SURE L.P. GAS IS COMPLETELY TURNED OFF AT THE LP GAS TANK.**

The furnace in the Motor Home is a Suburban Dyno-Trail furnace. It is a sealed combustion system furnace and is one of the following models:

NT-22G TYPE I (22,000 B.T.U.)

NT-32G TYPE I (30,000 B.T.U.)

NT-22G TYPE II (22,000 B.T.U.)

NT-32G TYPE II (30,000 B.T.U.)

Basically the combustion chamber is the same in all models as well as the blower, burner, and control assembly. But before any repairs or disassembly is attempted, it is necessary to be able to identify which model you are working with.

To do this, first determine whether the furnace you are working with is TYPE I or TYPE II. This can be quickly done by opening the furnace control access door. If the door opens horizontally, as shown in Figure 1, it is a TYPE I furnace. If the door opens vertically, as shown in Figure 1, the furnace is a TYPE II.

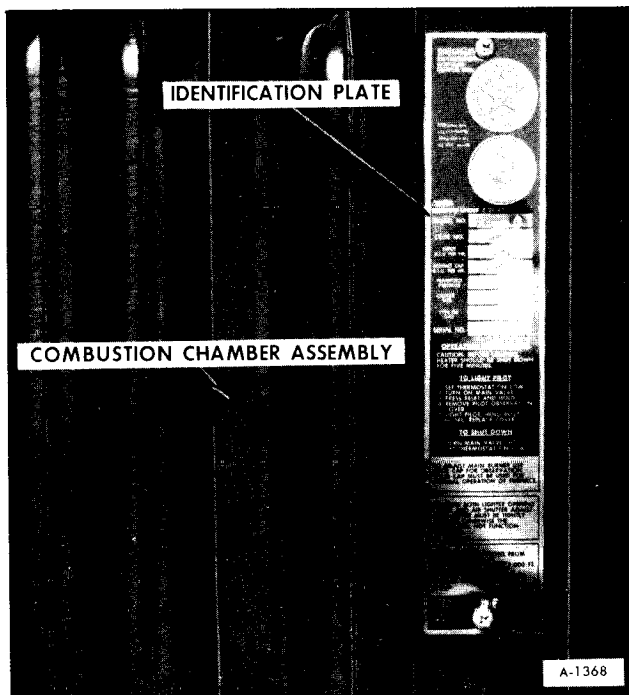

Figure 2—Furnace Identification Plate

Once it is determined whether the furnace is TYPE I or TYPE II you can then determine whether the furnace is a NT-22G or NT-32G by removing the cabinet front (one screw at top of cabinet) and reading the model number on the Furnace Identification Plate, located on the front of the combustion chamber (See figure 2).

This furnace utilizes a sealed combustion system with a patented dual blower, one of which circulates room air while the other furnishes outside air for combustion. The combustion air blower then forces the flue products to the outside for maximum safety and heating efficiency. The furnace operates on 12-volts and it's wiring diagram is shown in Figure 3.

**NOTE:** Combustion air must not be drawn from the living area!

Some of the components essential for proper furnace operation are:

### FAN SWITCH (FIGURE 4)

The fan switch is to control the sequence of the blower operation. The fan switch is a two pole switch. When the bimetal disc of the fan switch is heated to the operating temperature, the switch changes positions. This completes a circuit through the motor from a direct source. The blower will continue to run as long as the chamber is hot even though the thermostat is satisfied and the main burner is off. When the chamber cools, the fan switch changes back to its original position and shuts the blower off. If burner and blower shut off simultaneously after about 2 minutes of operation, and the thermostat is still calling for heat, then the fan switch failed to completely change over. This is a symptom of a faulty switch—replace it.

### LIMIT SWITCH (FIGURE 4)

The purpose of the limit control is to turn off the gas to the main burner if for any reason the furnace becomes hotter than that which is safe. Improper operation of the furnace due to the limit control does not always indicate a defective control. If the circulating air is blocked or only partially so, the limit control will function and cause the main burner to cycle. Cycling on the limit is not always undesirable—if it happens only occasionally. This is a good indication of safe operation and will most likely happen on a warm day. If cycling happens too often or for an extended period, the circulating air system should be thoroughly cleaned.



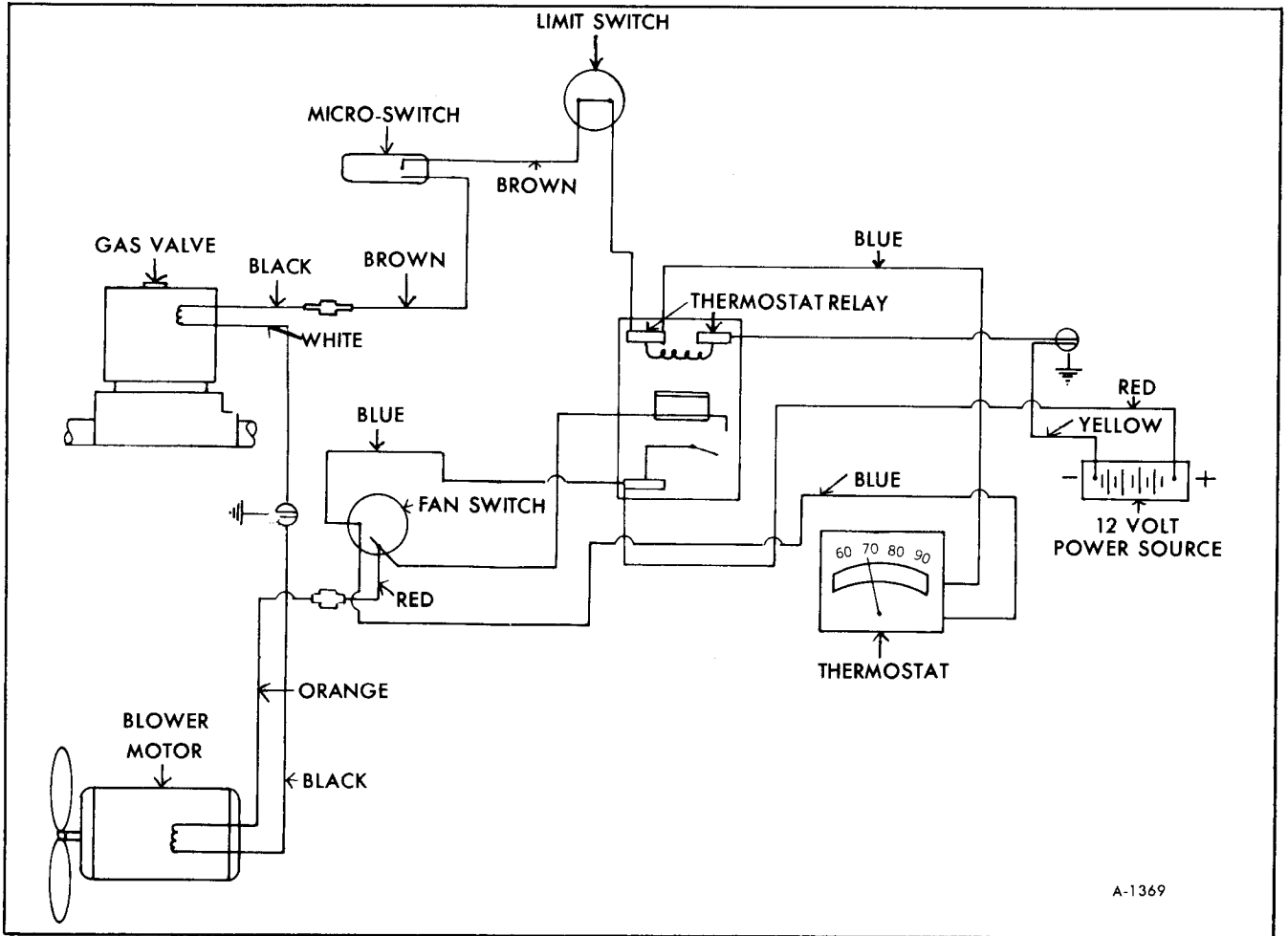

Figure 3—Furnace Wiring Diagram

If for any reason the limit control is found to be defective, there is no recommended method of repairing it. Because of its importance for safety rea-

sons, it should be replaced with a new one. **CAUTION: NEVER SHUNT THE LIMIT CONTROL EVEN FOR ONLY TEMPORARY OPERATION.**

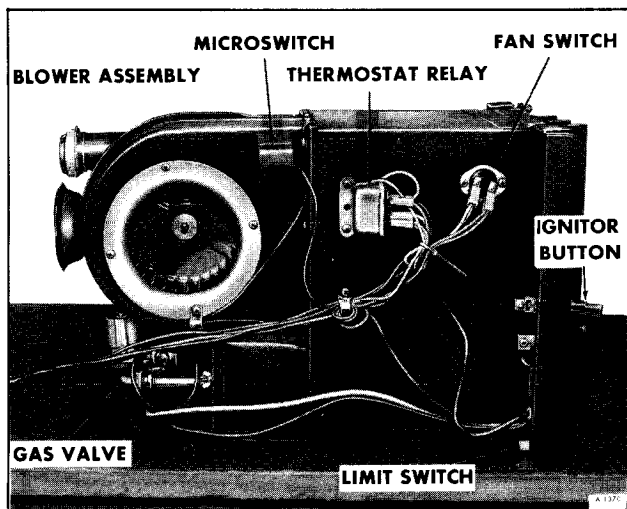

Figure 4—Furnace Components (Typical)

### MICROSWITCH (FIGURE 4)

The microswitch has two purposes:

1. It is an “air prover.” It operates in response to the current of air generated by the blower. Hence, if for any reason the air from the blower is not sufficient, the switch will not operate. This may be caused by a slow motor due to low voltage, restricted return air, or lint accumulation on the blower wheel.

2. The switch allows time for the blower to pull in a sufficient amount of air to support combustion before it engages. Once it engages, the solenoid valve opens, gas flows to burner, and ignition occurs.

## BLOWER ASSEMBLY (FIGURE 4)

The combustion-air blower is sealed so as to allow no passage of air between it and the circulating room-air blower. The combustion-air blower draws air from the outside atmosphere, discharge it into the combustion chamber, and forces the combustion products out the exhaust tube. The circulating room-air blower pulls return air in and forces it across the heat chamber, discharging into the area to be heated.

## IMPACT IGNITION SYSTEM (FIGURE 4)

This spark ignitor has been added to facilitate lighting. It is a solid state device with no outside current required.

Depressing the "Ignition Button" operates a lever on the device which, in turn, creates a spark at the ignitor tip. Normally the unit will ignite with the first spark. In the event the unit doesn't readily light with the ignitor, it's possible the ignitor tip may need repositioning—aligning the ignitor tip with the pilot gas flow can be accomplished through the lighter hole.

On initial lighting, air in the gas line may require several pumps of the "Ignitor Button" for ignition.

The ignitor does not prevent the lighting by match if desired.

## FURNACE OPERATION

1. To light the furnace, turn the manual valve (See figure 5) to the "off" position and wait 5 minutes. Set the thermostat at its lowest setting. Open manual valve. Correct operating characteristics depend on this valve being positioned fully open. Never attempt to operate with valve partially closed.

2. Open access door and remove lighter cap.

3. Press reset button and hold. Depress the impact ignitor button (See figure 5). On the initial lighting the pilot may not light immediately due to air in the gas line. If such is the case it may be necessary to hold the reset button in for a minute or more before the pilot lights. When the pilot is burning, continue to hold the reset button in for approximately 30 seconds or until the pilot continues to burn when the reset button is released.

4. Replace the lighter hole cap.

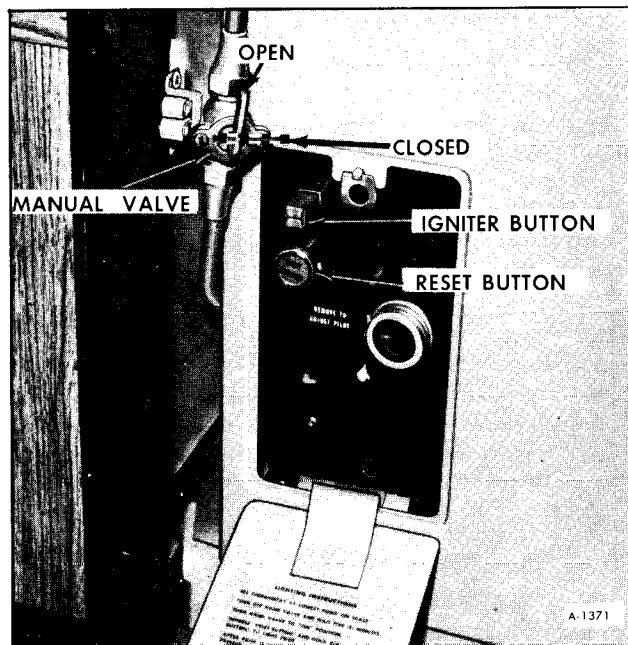

Figure 5—Manual Valve, Reset and Ignitor Buttons

5. Close access door.

6. Set thermostat at desired position.

## SEQUENCE OF NORMAL OPERATION

1. When the thermostat calls for heat, the blower motor is energized immediately.

2. As the blower motor reaches approximately 75 percent of the normal r.p.m. (within 3 to 5 seconds) the microswitch, in response to the air flow, will engage allowing current flow to the solenoid valve or base valve.

3. The current to the valve opens it and allows gas to the main burner. The pilot light then ignites the main burner.

4. If within a period of approximately 2 minutes after the main burner is lit, the thermostat is turned back, both the blower motor and gas valve are deenergized. However, if the furnace continues to run longer than 2 minutes, which it normally should, a slight snap can be heard from within the casing. The snap is caused by the fan switch as it changes its position. After this occurs, if the thermostat is satisfied or turned back, the gas valve will close, the flame on the main burner will go out, but the blower will continue to run for a short period of time and will then shut off. The purpose of this is to remove most of the remaining gases from the heat exchanger. Be assured that this period of blower override is a part of the unit's normal operation.

# FURNACE TROUBLE DIAGNOSIS CHART

Problem	Possible Cause	Correction
No heat.	<ol style="list-style-type: none"> <li>1. Thermostat off.</li> <li>2. Gas supply.</li> <li>3. Pilot.</li> <li>4. Electrical connections or power.</li> <li>5. Malfunctioning micro-switch.</li> </ol>	<ol style="list-style-type: none"> <li>1. Check to be sure thermostat is calling for heat. Wire to thermostat could be off terminal.</li> <li>2. Be sure manual gas valve is in the open position (level parallel to gas line). Also, check to be sure there is LP gas in the LP tank.</li> <li>3. Check to see that pilot is lit. (See Problem-Pilot Outage).</li> <li>4. Battery must be charged. If battery is low, there will be sufficient power to run the blower, but not enough to run the blower at full speed. If blower doesn't run at its prescribed speed, the micro-switch cannot be engaged and gas will not flow to the main burner. Be sure the connection of the voltage lines in the terminal block are tight.</li> <li>5. Be sure the microswitch is "sailing" in far enough to open the gas valve. If the switch is not "sailing" in, clean any dust or dirt from the actuator pin. Other reasons for switch not sailing in are:               <ol style="list-style-type: none"> <li>a. Insufficient blower speed (slow motor due to low charged battery, faulty motor, or lint and dust accumulation on the blower wheels, or restriction of return air to furnace). Check wiring in accordance with unit's wiring diagram to assure the proper polarity of the 12-volt d.c. power supply is observed. This polarity must be observed so the motor will run the proper direction of rotation to insure correct air delivery.</li> <li>b. Faulty microswitch—Replace switch if valve doesn't open when switch is manually engaged. Switch should also be replaced if battery is fully charged and blower motor running at top speed fails to engage switch within 6 to 7 seconds.</li> </ol> </li> </ol> <p>NOTE: To service switch, combustion chamber must be pulled out.</p>

Problem	Possible Cause	Correction
	<p>6. Gas valve.</p> <p>7. Blower not operating.</p> <p>8. Short cycling (fan switch)—If burner and fan shut off simultaneously when the fan switch closes (2 or 3 minutes after burner comes on) it indicates a shorted fan switch.</p> <p>9. Defective thermostat relay—Relay may be faulty if motor fails to start when thermostat calls for heat. This will be evidenced when the wall thermostat is turned up but the motor fails to start and there is no “click” in the thermostat relay. If a “click” is heard in the thermostat relay but the motor fails to start then it is the motor that is defective.</p>	<p>6. Gas valve—With test light check gas valve terminals in the terminal block. If current is present, but valve is not opening (when micro-switch engages), replace gas valve. The chamber must also be removed to check the above.</p> <p>7. Check for burned-out motor.</p> <p>8. Replace fan switch.</p> <p>9. Replace thermostat relay.</p>
<p>Pilot Outage</p> <p>Pilot outage can be due to several reasons. To isolate the source of a pilot outage complaint, it is very helpful to determine exactly when the pilot is going out. There are three phases of the unit operation:</p> <ol style="list-style-type: none"> <li>Off phase.</li> <li>Start up or ignition phase.</li> <li>Operating phase.</li> </ol> <p>If the time of outage can be linked to one of these phases, then possible sources can be isolated.</p>	<p><u>A. Off Phase</u></p> <p>1. Weak thermocouple or gas valve—Thermocouples are generally long lived, but failures can occur after a period of use. If the pilot is observed going out during the off cycle, it could be due to either a weak thermocouple or safety pilot valve. A simple check can be made in the field by a time check. Remove the lighter hole cap and extinguish the flame after the pilot has been lit for approximately 5 minutes. Use a watch to check the time that elapses between extinguishing the pilot and the snap of the safety valve. If this is less than 30 seconds, it indicates a weak thermocouple or gas valve.</p>	<p><u>A. Off Phase</u></p> <p>1. Replace the thermocouple first and repeat the test for the safety pilot valve. If the time lapse is still less than 30 seconds, replace the safety pilot valve.</p>

Problem	Possible Cause	Correction
(continued from previous page).	<p>2. Air leakage-Draft should not affect the pilot. The unit has a sealed combustion chamber with an air intake and exhaust subject to the same atmospheric pressure. Therefore, the pressure within the chamber is equalized and air is steady. Regardless of the wind or draft condition the pilot will not be blown out as long as the chamber is sealed properly. If, however, a leak is evident, it would disrupt the pressurized chamber, and a draft air movement would commence. As a result the pilot could possibly go out.</p>	<p>2. The following are points to check for air leakage. The unit should be pulled and all of these points should be carefully checked.</p> <ul style="list-style-type: none"> <li>a. Pilot burner gasket must be absolutely tight.</li> <li>b. Air shutter adjustment cover gasket must be absolutely tight.</li> <li>c. Vacuum cup on air intake tube should fit against cabinet back so that no room air can enter air intake.</li> <li>d. Asbestos exhaust gasket should be fitted properly at the end of the exhaust tube to insure proper seal.</li> <li>e. Lead-in wires to the blower motor should be sealed where they enter the blower housing.</li> <li>f. All other gasket points; e.g., blower assemblies, sponge rubber gaskets.</li> <li>g. It is possible that the felt gasket on the interior of the blower assembly may not be properly sealed. If not, air can flow from the sealed combustion compartment which is, in effect, air leakage. Checking this point will necessitate breaking down the blower assembly; therefore, it should be the last point to check. Nevertheless, this is an important hint as this could also be a contributing factor to pilot outage.</li> <li>h. Restriction of exhaust tube-Visually check rear exhaust tube opening for blocking of discharge of exhaust products.</li> <li>i. Crossover tube between lower section of blower assembly and burner tunnel may be cracked, deteriorated, or off the blower assembly flange or burner tunnel. Replace if cracked or deteriorated.</li> </ul>

Problem	Possible Cause	Correction
<p>(Continued from previous page).</p>	<p>3. Lack of sufficient air—Another reason for pilot outage during the off cycle is the lack of sufficient air to support proper pilot flame adjustment. It is important that the flame be the proper size. Unlike most heating equipment, too large a flame is a common cause of pilot outage. It should be just high enough to envelop the thermocouple. If the pilot flame is other than this or yellowish in color, replace the pilot orifice.</p> <p>4. Leaky gas valve—If gas leaks by the gas valve during the off burner periods, it burns, using the oxygen in the chamber and causing the pilot to go out because of lack of oxygen. Observe the main burner through the lighter hole to be sure that the burner cuts off completely on the off cycle. If a flame is present, no matter how small, it indicates that a small amount of gas is leaking through.</p> <p>5. Malfunctioning microswitch—Make sure the microswitch is dropping all the way out and breaking the connection in the gas valve on the off cycle of the blower.</p> <p>6. Gas supply—Check gauge for proper gas supply and pressure.</p> <p>7. Clogged pilot orifice—Evident by small pilot flame.</p> <p>8. Pilot adjustment.</p> <p><u>B. Start-up or Ignition Phase</u> If the pilot is observed and is going out when the burner comes on, check for the following:</p>	<p>3. Replace the pilot orifice.</p> <p>4. If there is leakage, inspect the valve to be sure there is no dirt between the valve and valve seat. If there is no dirt to account for the trouble, replace the valve.</p> <p>5. Replace microswitch.</p> <p>6. Check for proper gas supply and pressure.</p> <p>7. Replace the pilot orifice.</p> <p>8. Pilot should be adjusted to where the pilot flame just envelops the thermocouple tip.</p> <p><u>B. Start-up or Ignition Phase</u></p>

Problem	Possible Cause	Correction
<p>(continued from previous page).</p>	<p>1. Malfunctioning micro-switch—The microswitch allows gas to reach the main burner by closing the circuit through the gas valve, after the blower motor has started and reached approximately 75 percent of its maximum r.p.m. This takes about 3 to 5 seconds. If the microswitch opens the gas valve too soon, the main burner flame may float and pull the pilot flame out. This is caused by lack of oxygen in the combustion chamber.</p> <p>2. Primary air—Too little primary air will cause burner to float on ignition and could pull pilot out.</p> <p><u>C. Operation Phase</u>            1. If burner and fan shut off simultaneously when the fan switch closes 2 to 3 minutes after the burner comes on, it indicates a shorted fan switch. Replace the switch. If this symptom occurs, it is also possible for the pilot to go out because the blower was not allowed to run and purge out the combustion products. The excessive amount of combustion products can smother the pilot.</p>	<p>1. If microswitch is engaging too fast, replace switch.</p> <p>2. Adjust primary air. (See Burner Adjustment).</p> <p><u>C. Operation Phase</u>            1. Replace the fan switch.</p>
<p>Excessive Noise.</p>	<p>1. Blower out of balance.            2. Motor hum.            3. Air adjustment—A screeching or howling noise while burner is on is due to excessive primary air.</p>	<p>1. Replace blower.            2. Replace motor.            3. Adjust primary air. (See Burner Adjustment)</p>
<p>Erratic Blower operation</p>	<p>1. Automatic blower motor overload switch may be defective.            2. Blower assembly may be loose causing squirrel cage wheel to drag.</p>	<p>1. Replace blower            2. Check blower assembly - secure if loose.</p>

Problem	Possible Cause	Correction
Furnace will not operate.	<ol style="list-style-type: none"> <li>1. Power supply.</li> <li>2. Wall thermostat—Be sure thermostat is set for a temperature higher than that of the Motor Home</li> <li>3. Loose or shorted wiring.</li> </ol>	<ol style="list-style-type: none"> <li>1. Check power source and fuse.</li> <li>2. Remove wall thermostat and connect the two wires to it together. If the furnace starts, replace thermostat.</li> <li>3. Check all wiring to assure proper connections or detect possible shorts.</li> </ol>

## COMBUSTION CHAMBER REPLACEMENT

**WARNING: BEFORE ANY REMOVAL OR DISASSEMBLY PROCEDURES ARE PERFORMED ON THE FURNACE, BE SURE L.P. GAS IS COMPLETELY TURNED OFF AT THE L.P. GAS TANK.**

**WARNING: DUE TO THE POSSIBILITY OF INJURY ON SHARP SHEET METAL, CARE SHOULD BE TAKEN ANY TIME SERVICE IS PERFORMED ON THE FURNACE.**

### REMOVAL

1. Be sure L.P. gas is turned off at the tank. Turn the electricity off at the thermostat as shown in Figure 6.

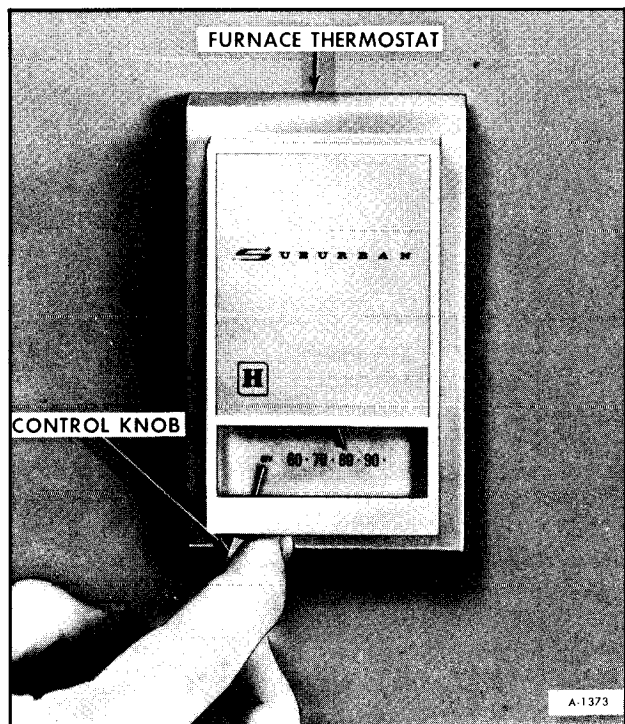

Figure 6—Turning Off Electricity To Furnace At Thermostat

2. Disconnect the main gas line at elbow fitting.

3. Remove cabinet front (one screw at top of cabinet front) (figure 7).

4. Remove the screw securing chamber to cabinet (lower right corner) as shown in Figure 8.

5. Remove the four vent cap screws (outside vehicle). Then remove the vent cap adapter screws (two) to free the exhaust tube (See figures 9 and 10).

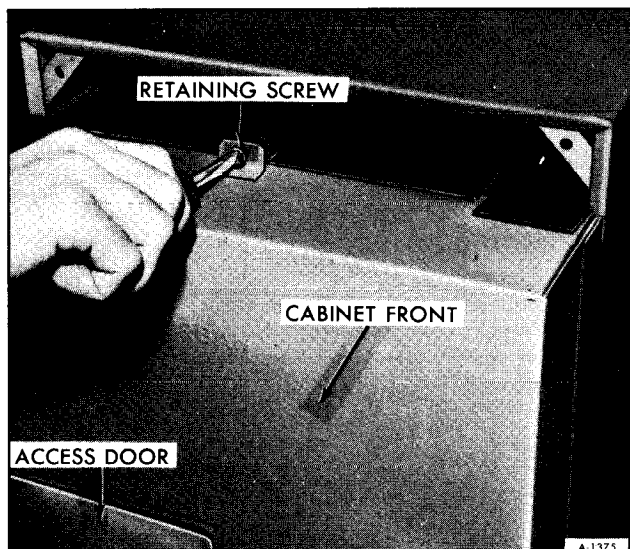

Figure 7—Removing Cabinet Front



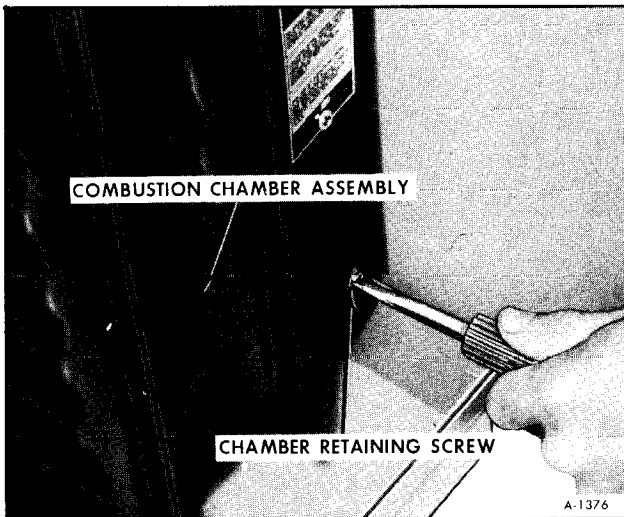

Figure 8—Removing Chamber Retaining Screw

6. Pull chamber forward until wires can be disconnected at the terminal connector (See figure 11). Remove chamber.

## INSTALLATION

1. Position rear of combustion chamber in cabinet slides, and move it partially in until the wires can be connected at the terminal connector (See figure 11). Push chamber all the way in to cabinet.

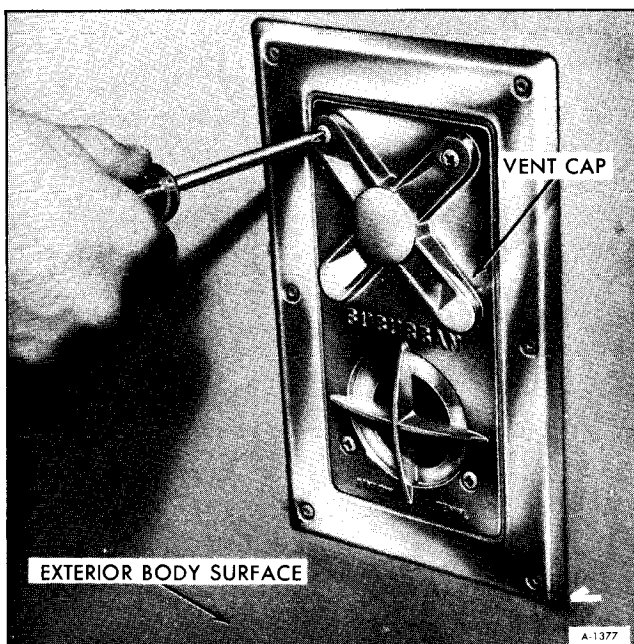

Figure 9—Removing Vent Cap

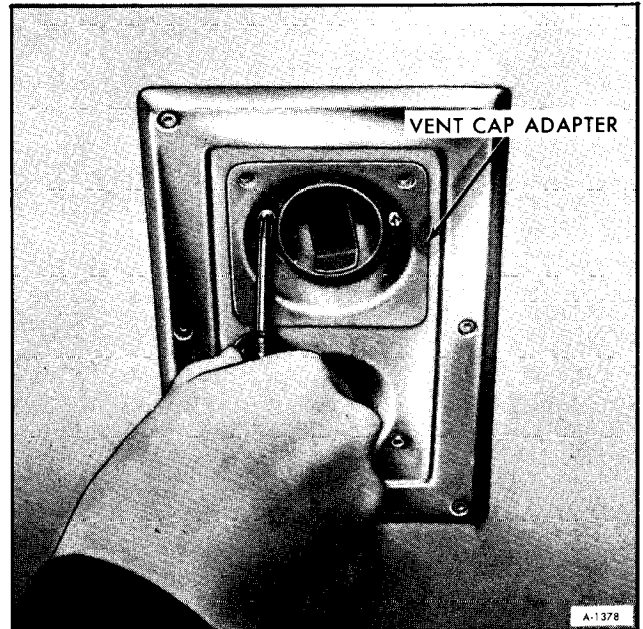

Figure 10—Removing Vent Cap Adapter

2. Install vent cap adapter and be sure rubber cup is properly seated. Install the vent cap (outside vehicle) (See figures 9 and 10).

3. Install screw securing chamber to cabinet (lower right corner) (figure 8).

4. Install cabinet front being sure the edges are set properly in all groves. Secure with one screw at top (See figure 7).

5. Connect the main gas line and connect or turn on electricity (figure 6).

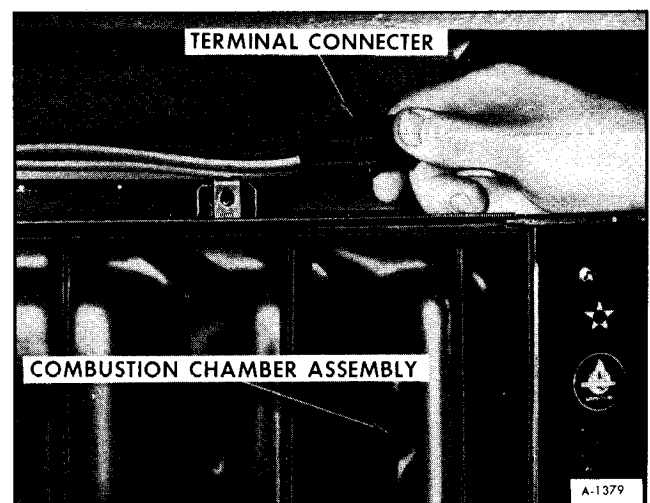

Figure 11—Furnace Thermal Connector

## COMPONENT REPAIR

**NOTE:** For furnace model identification refer to "General Information" as described at the beginning of this section.

### MICROSWITCH REPLACEMENT

#### REMOVAL

1. Remove combustion chamber from cabinet (See Combustion Chamber Replacement).
2. Remove microswitch shield (figure 12).
3. Remove two screws and nuts holding microswitch assembly in blower housing and remove switch (See figure 13).
4. Disconnect microswitch wires at gas valve and limit switch (remove wire clip).

#### INSTALLATION

1. Install microswitch in blower housing and secure with two screws and nuts (figure 13).
2. Connect microswitch wires.
3. Install microswitch shield (figure 12).
4. Install combustion chamber in cabinet (See Combustion Chamber Replacement).

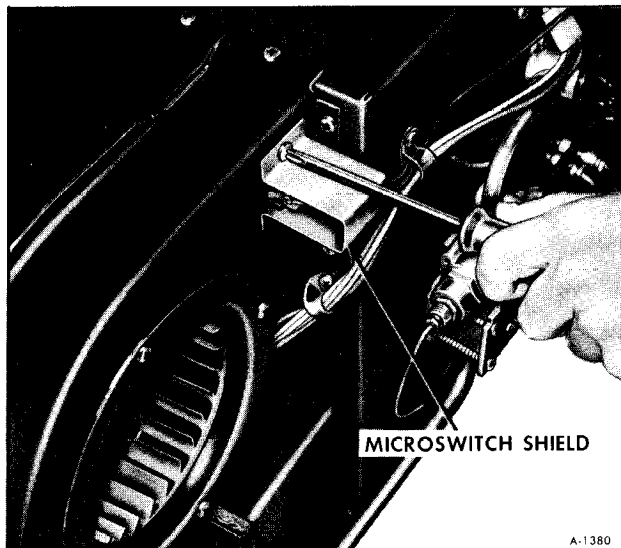

Figure 12—Removing Microswitch Shield

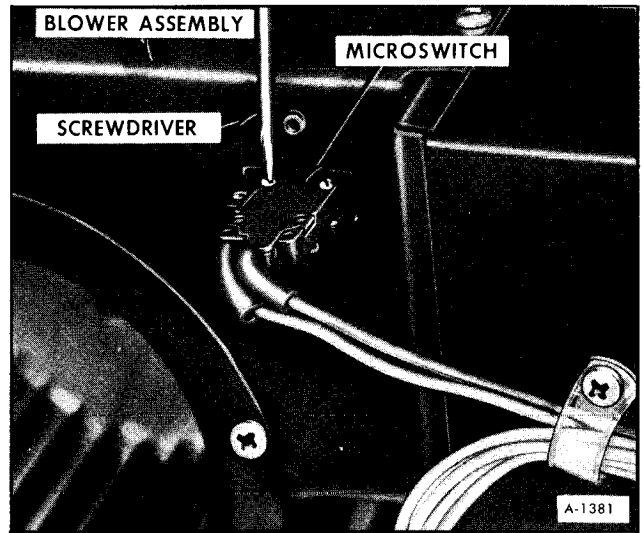

Figure 13—Removing Microswitch

### GAS VALVE OR PILOT SAFETY REPLACEMENT (TYPE I FURNACES)

**NOTE:** The NT-22G TYPE I has its gas valve and pilot safety as two separate valves (See figure 14), whereas the NT-32G TYPE I has both these valves incorporated into one (See figure 15). But, the gas valve (and pilot safety) replacement procedures are similar for both the NT-22G TYPE I and the NT-32G TYPE I.

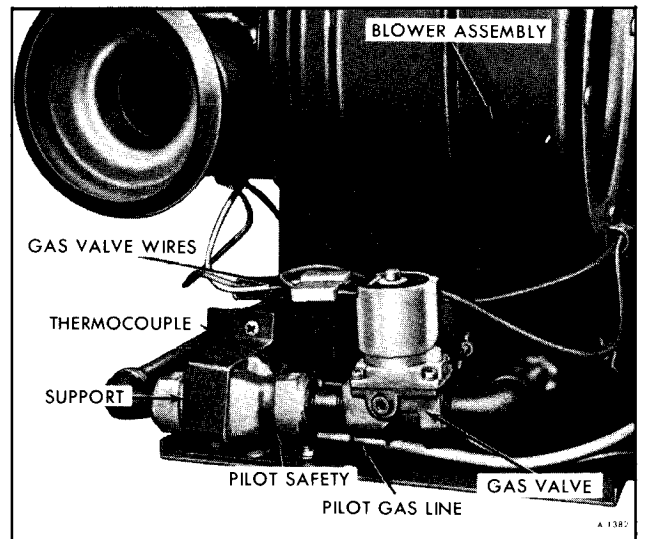

Figure 14—(NT-22G) Gas and Pilot Safety Valve

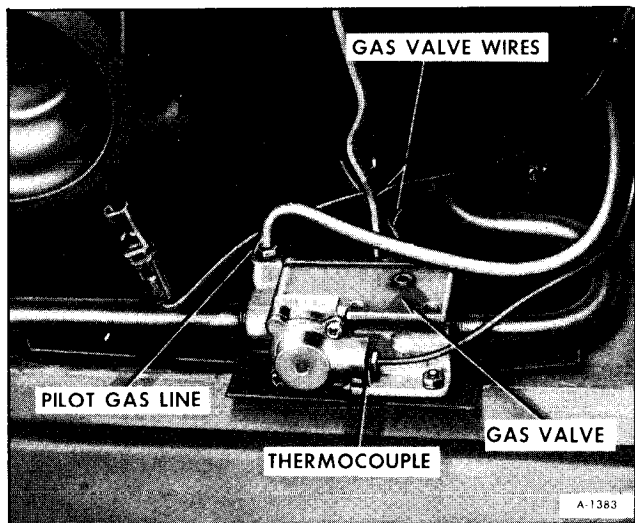

Figure 15-(NT-32G) Gas Valve

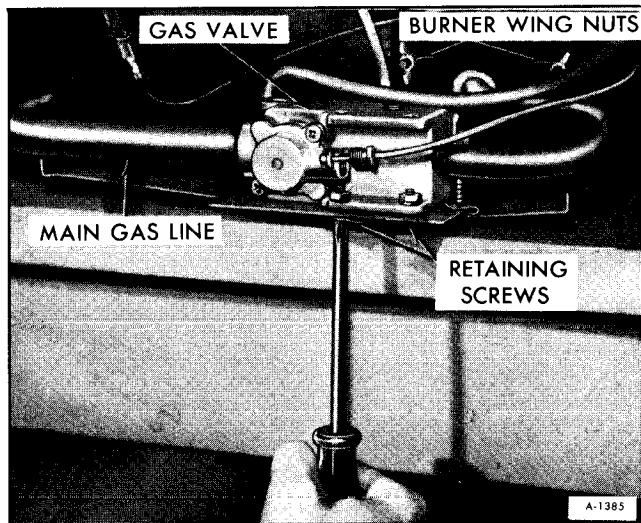

Figure 17-(NT-32G) Removing Gas Valve Retaining Screws

## REMOVAL

1. Remove combustion chamber from cabinet (See Combustion Chamber Replacement).
2. Disconnect pilot gas line, thermocouple and wires from valve(s) (See figures 14 and 15).
3. Remove main gas line support(s).
4. Remove screws and nuts holding valve to chamber (See figures 16 and 17).

5. Remove two wing nuts at rear of burner compartment.
6. Remove burner, valve(s), and main gas line all as a unit (See figure 18).
7. Disassemble and remove defective component (See figure 19).

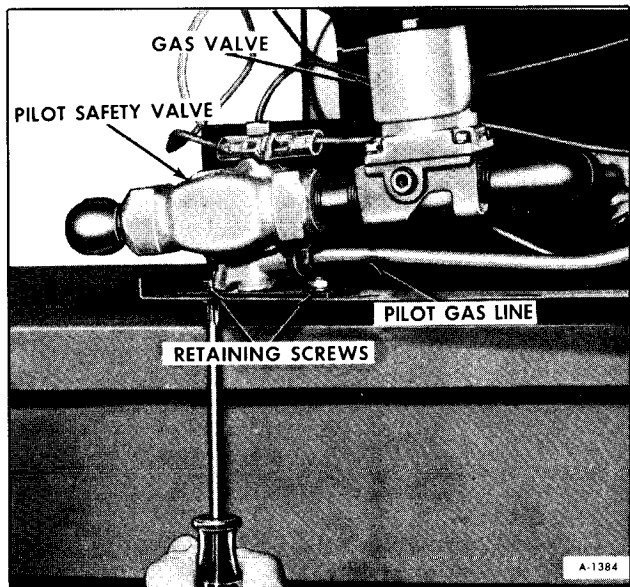

Figure 16-(NT-22G) Removing Pilot Safety Valve Retaining Screws

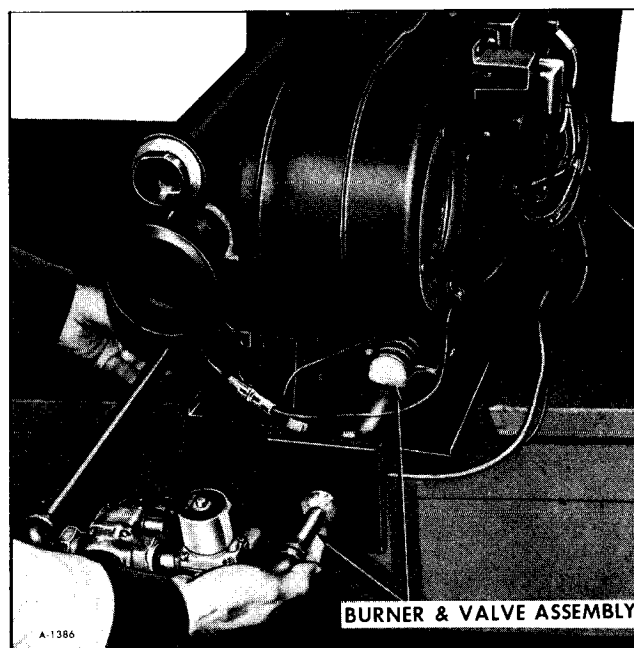

Figure 18-Removing Burner and Valve

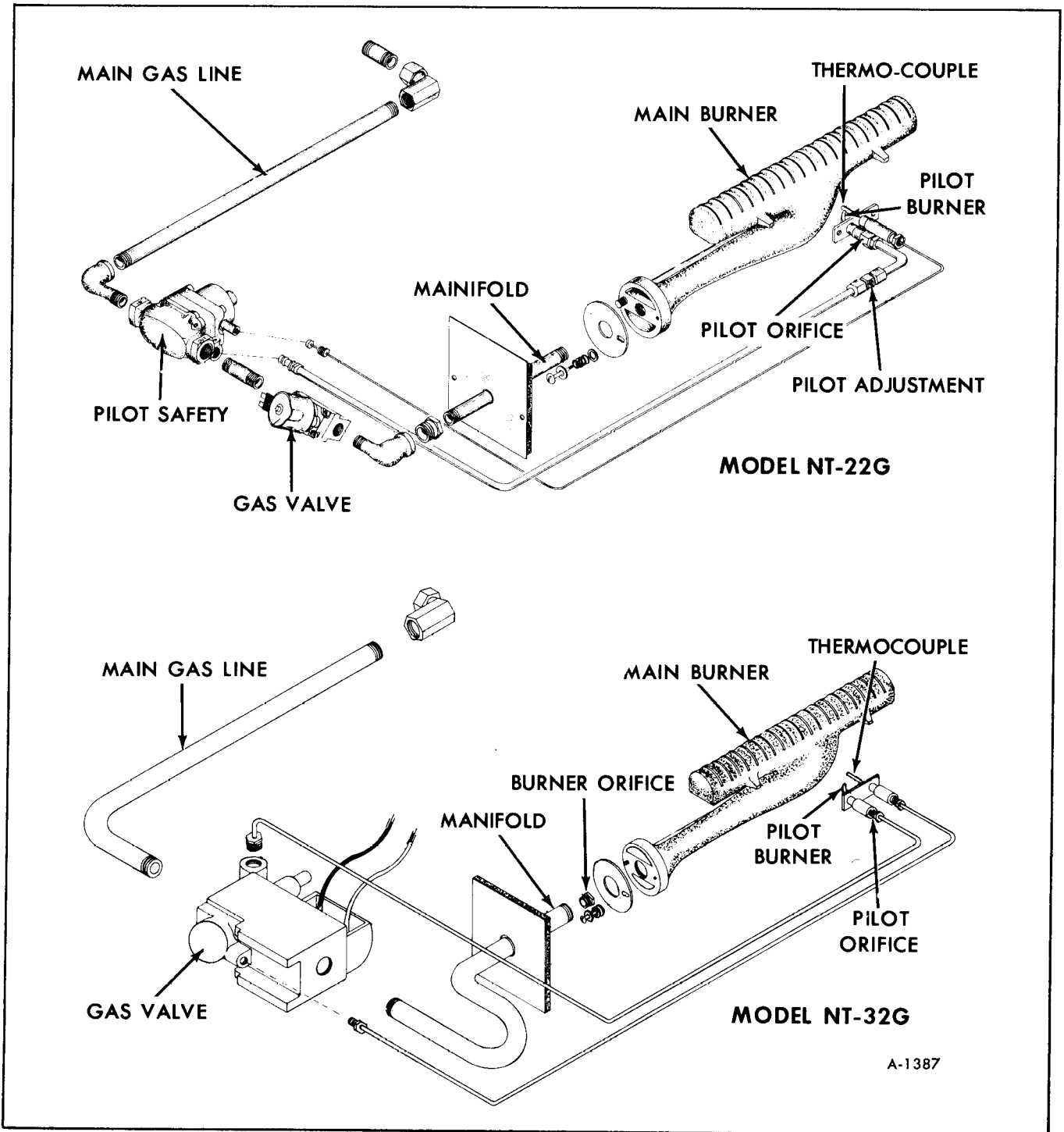

Figure 19-(NT-22G and NT-32G) Valve and Burner Assemblies

## INSTALLATION

1. Assemble burner, valve(s), and gas line as a unit (figure 19).

2. Install burner, valve(s) and gas lines in combustion chamber as a unit (See figure 18).

3. Install wing nuts at rear of burner compartment.

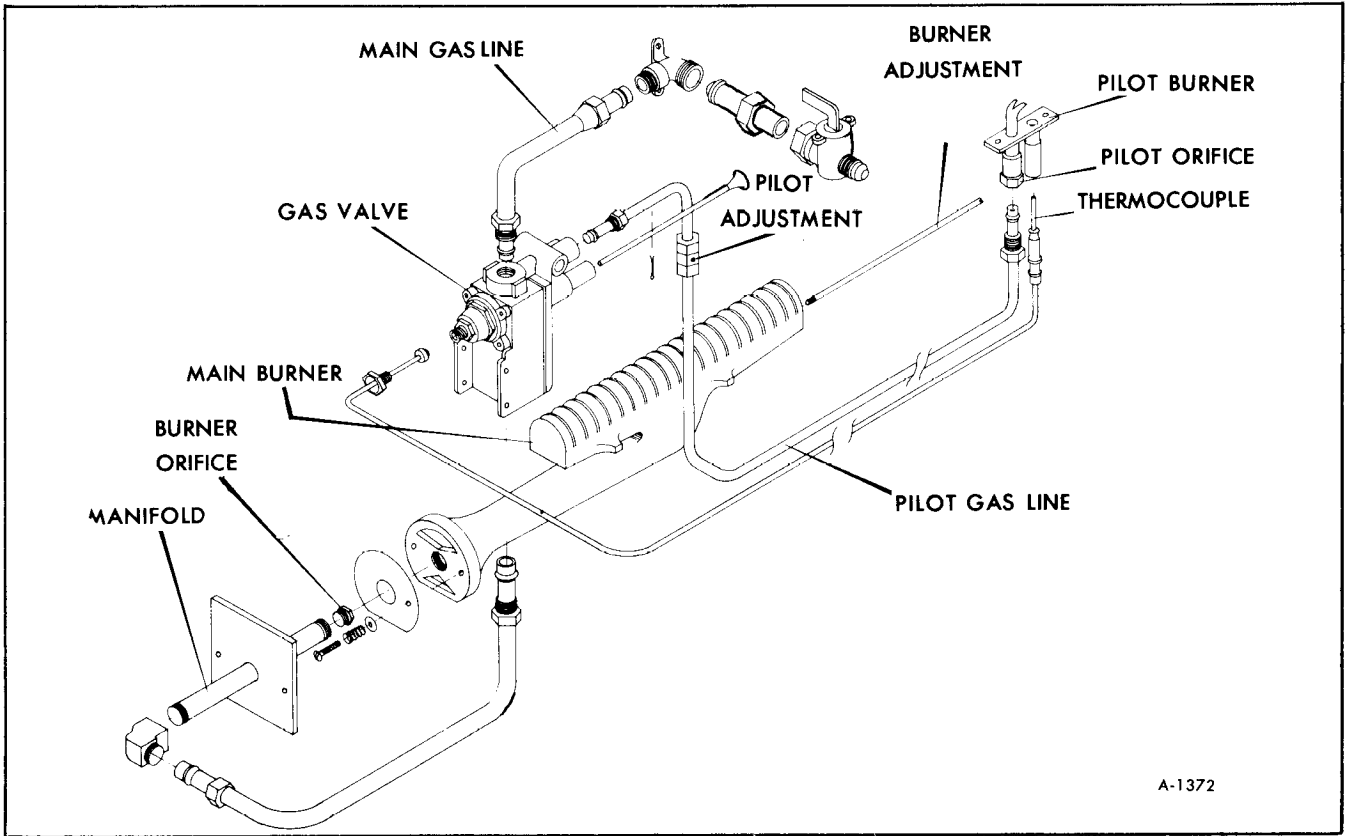

A-1372

Figure 20—Type II Valve and Burner Assembly

4. Install screws and nuts holding valve to chamber (figures 16 and 17). Be sure pilot reset rod and bracket are properly aligned.

5. Install main gas line support(s).

6. Connect pilot gas line, thermocouple, and wires at valve(s) (figures 14 and 15).

7. Install combustion chamber in cabinet (See Combustion Chamber Replacement).

3. Disconnect all lines from gas valve (inlet, outlet, pilot, and thermocouple (figure 21).

4. Remove the two screws holding gas valve to the chamber side as shown in Figure 22.

## GAS VALVE REPLACEMENT (TYPE II FURNACES)

### REMOVAL (FIGURE 20)

1. Remove combustion chamber from cabinet (See "Combustion Chamber Replacement").

2. Disconnect the two wires at gas valve shown in Figure 21.

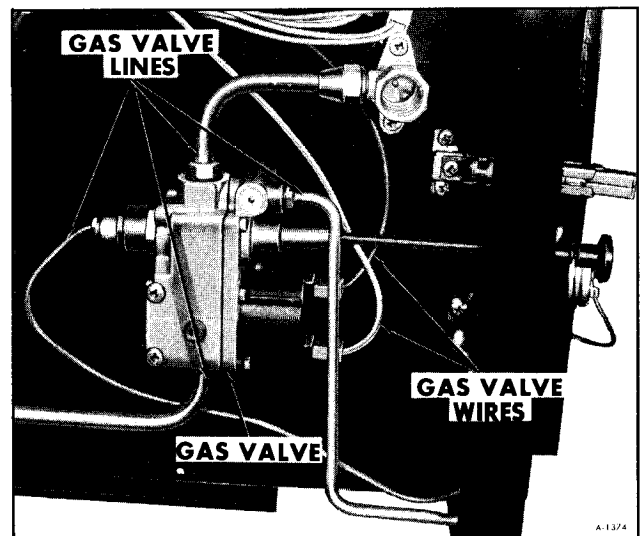

A-1374

Figure 21—Gas Valve Wires and Lines

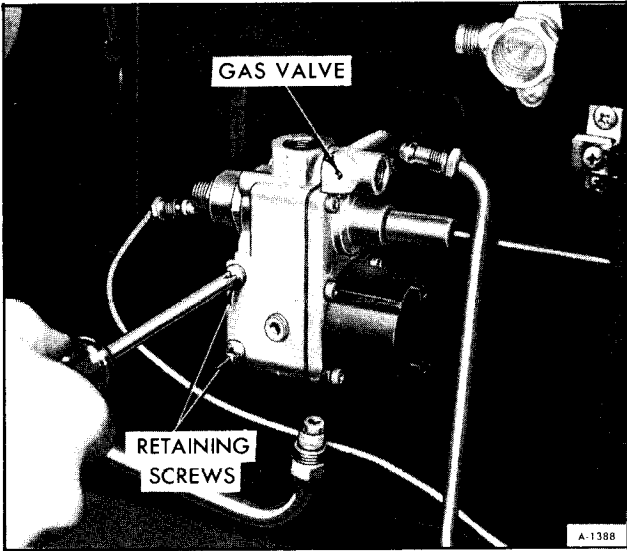

Figure 22-Removing Gas Valve

## INSTALLATION

1. Secure gas valve to chamber side with two screws (figure 22) (be sure pilot reset rod is properly positioned in valve).
2. Connect all lines to gas valve (See figure 21) inlet, outlet, pilot and thermocouple.
3. Connect two wires at gas valve.
4. Install combustion chamber in cabinet (See "Combustion Chamber Replacement").

## BLOWER ASSEMBLY (NT-22G) (FIGURE 23)

### DISASSEMBLY

1. Remove combustion chamber from cabinet (See Combustion Chamber Replacement).

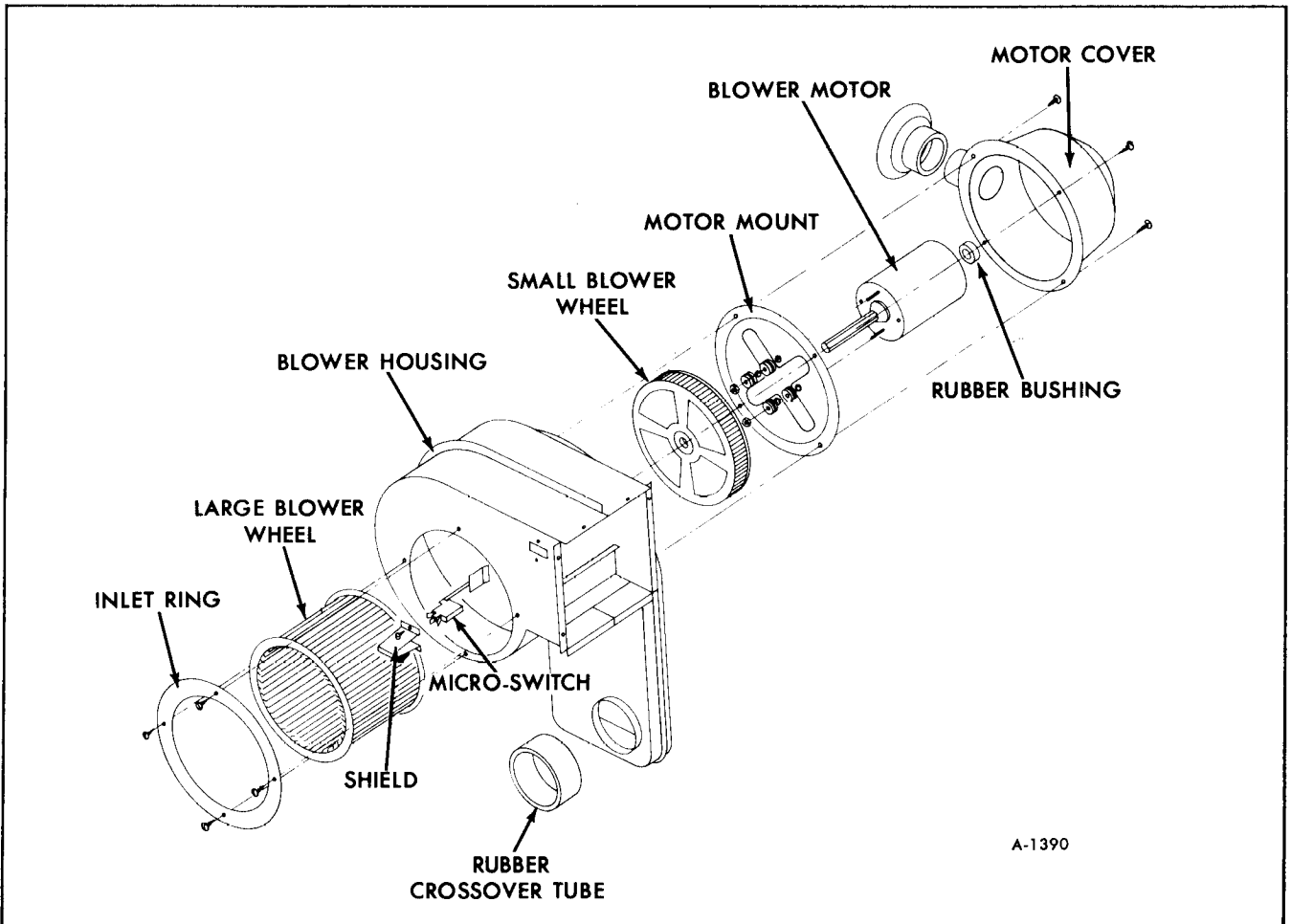

Figure 23-(NT-22G) Blower Assembly

2. Disconnect microswitch wires at gas valve and limit switch.
3. Disconnect red blower motor wire at quick disconnect.
4. Remove five screws holding blower assembly to furnace (figure 24).
5. Remove blower assembly.
6. Remove large blower wheel inlet ring (4 screws) (figure 25).
7. Remove large blower wheel (1/8 inch Allen wrench) (See figure 26).
8. Remove motor cover (4 screws) (See figure 27). Motor, motor mount assembly, and small blower wheel will then come free from the blower housing (See figure 23).
9. Remove small blower wheel (1/8 inch Allen wrench).
10. Remove motor mount assembly from motor (2 nuts) as shown in Figure 23.

**ASSEMBLY**

1. Assemble motor to motor mount assembly (2 nuts).
2. Install small blower wheel on motor shaft (1/8" Allen wrench).
3. Position motor, motor mount assembly, and

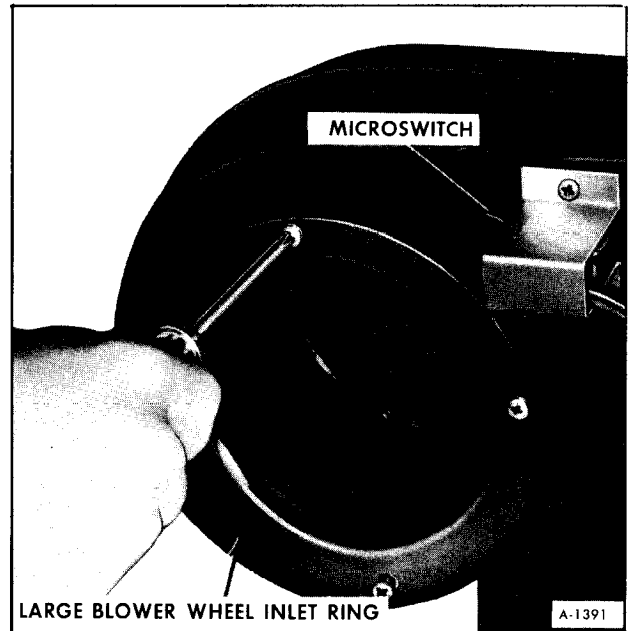

Figure 25-Removing Blower Wheel Inlet Ring

small blower wheel on blower housing and align screw holes (See figure 23).

4. Position motor cover over motor, being sure rubber bushing is properly installed between motor and cover (figure 23).

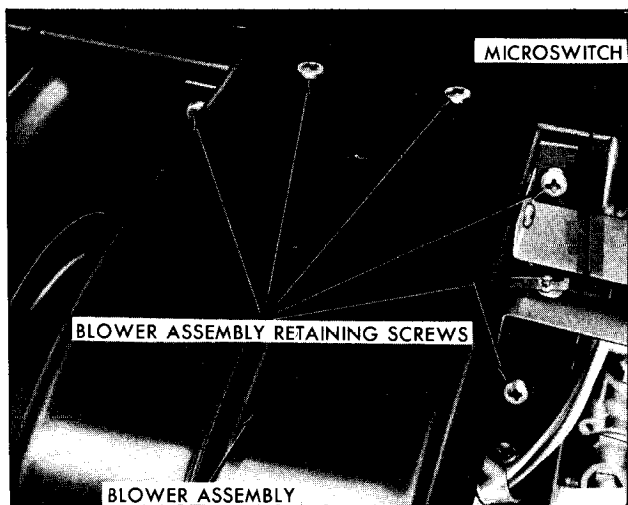

Figure 24-Blower Assembly Mounting Screws

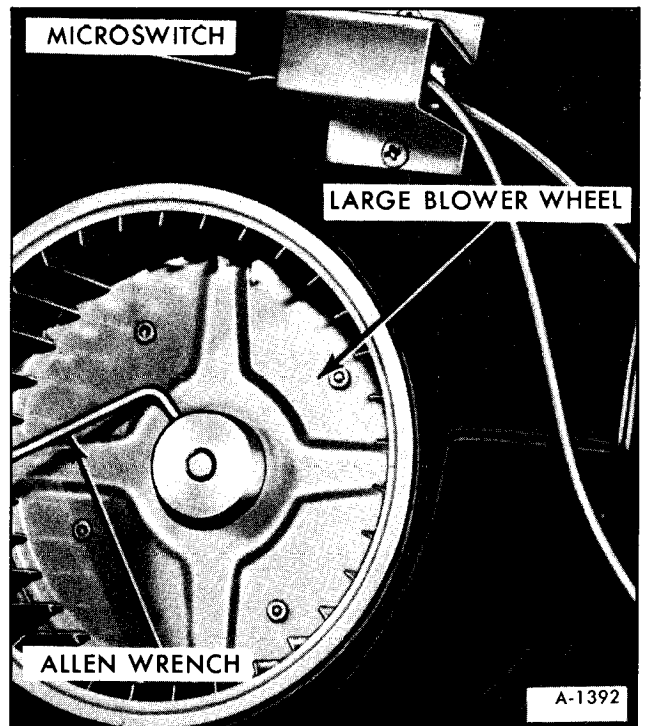

Figure 26-Removing Large Blower Wheel

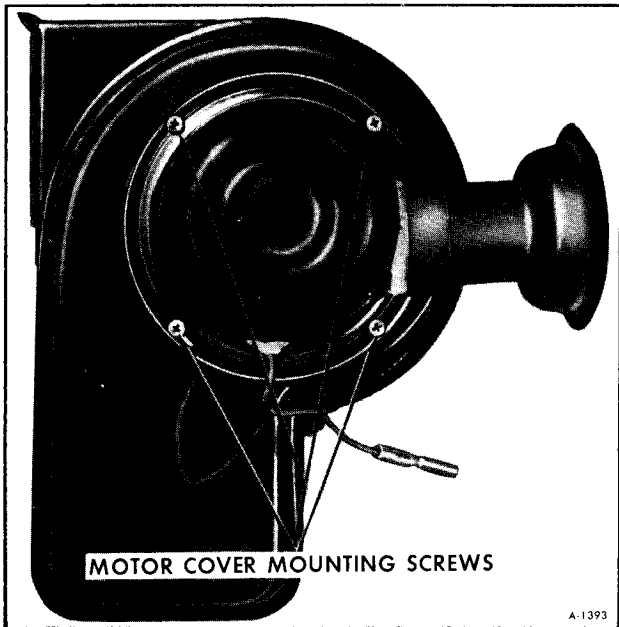

Figure 27—Motor Cover Mounting Screws

5. Align holes with those in motor mount assembly and install screws (See figure 23). (The motor ground wire attaches to one of these screws).

6. Install large blower wheel on motor shaft (1/8" Allen wrench) (figure 26).

7. Install large blower wheel inlet ring to housing (4 screws) (figure 25).

8. Position blower assembly on furnace, being

sure rubber crossover tube is properly seated at combustion chamber and at bottom of blower.

9. Install the five screws holding blower assembly to the furnace shown in Figure 24.

10. Connect blower motor wire at quick disconnect.

11. Connect microswitch wires at gas valve and limit switch.

12. Install combustion chamber in cabinet (See Combustion Chamber Replacement).

## BLOWER ASSEMBLY (NT-32G) (FIGURE 28)

### DISASSEMBLY

1. Remove combustion chamber from cabinet (See Combustion Chamber Replacement).

2. Disconnect microswitch wires at gas valve and limit switch.

3. Disconnect the two blower motor wires.

4. Remove the six screws holding blower assembly to furnace (See figure 29) (one at bottom of assembly).

5. Remove blower assembly (figure 30).

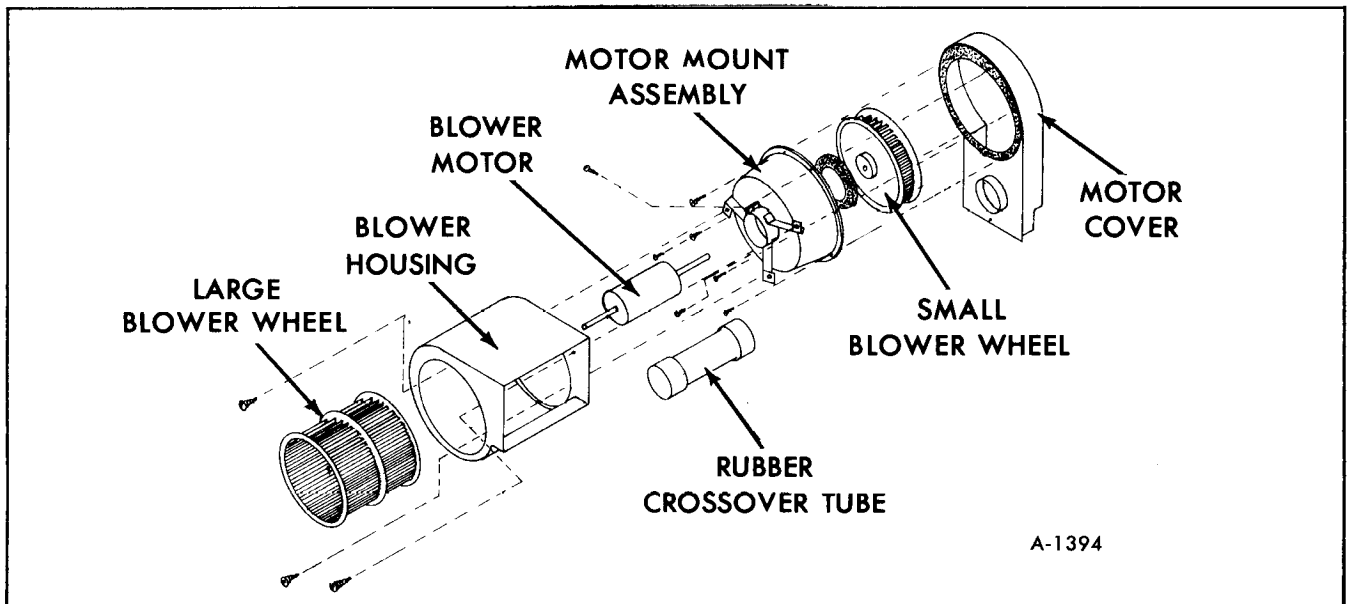

Figure 28—(NT-32G) Blower Assembly



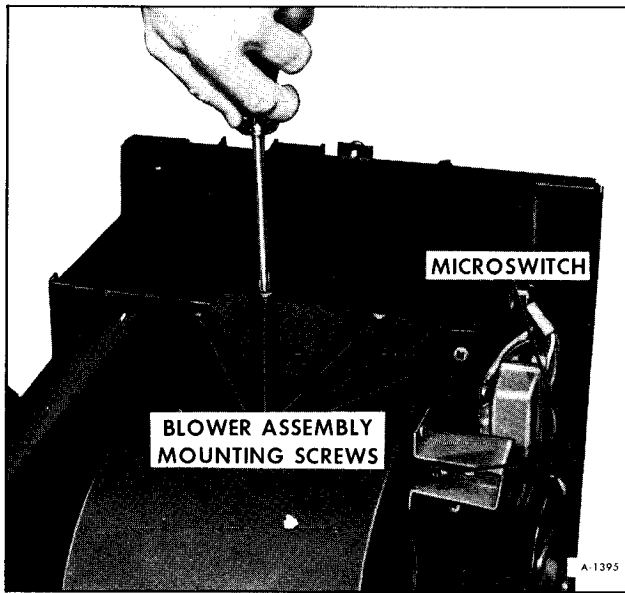

Figure 29—Removing Blower Assembly Screws

6. Remove large blower wheel (1/8" Allen wrench) (See figure 26).

7. Remove three screws and nuts holding large blower wheel housing (Shown in figure 28).

8. Remove motor mount assembly from motor cover (5 screws) (figure 31).

9. Loosen motor cinch screw and push motor and small blower wheel out of motor housing (See figure 32).

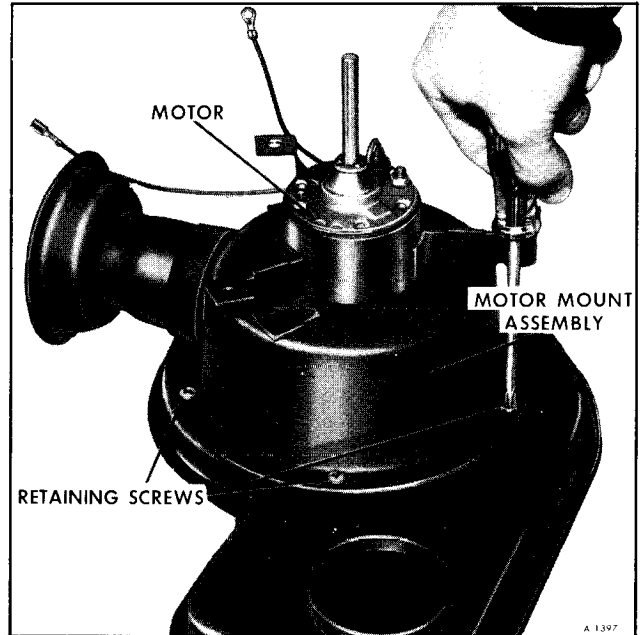

Figure 31—Removing Motor and Mount Assembly Retaining Screws

10. Remove small blower wheel (1/8" Allen wrench) (Figure 28).

### ASSEMBLY

1. Position motor in motor mount assembly. Tighten cinch screw (figure 32).

2. Install small blower wheel (figure 28).

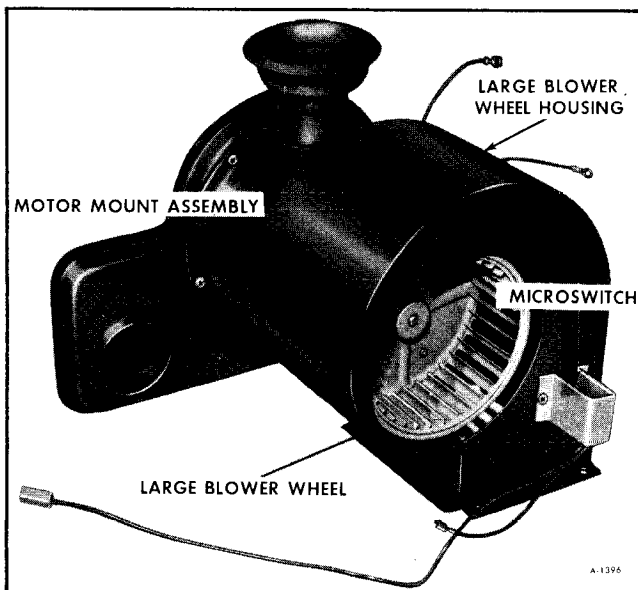

Figure 30—Blower Assembly - Removed

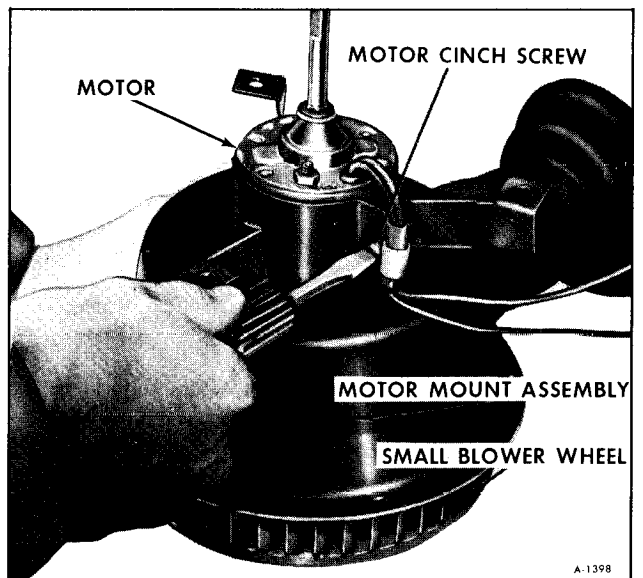

Figure 32—Removing Motor Cinch Screw

3. Assemble motor housing to small blower wheel housing (5 screws) (See figure 31).

4. Install large blower wheel housing to motor housing brackets (See figure 28) (3 screws and nuts).

5. Install large blower wheel (1/8" Allen wrench) (figure 26).

6. Position blower assembly on furnace being sure rubber crossover tube is properly seated at combustion chamber and at bottom of blower assembly. Install all screws.

7. Connect the two blower motor wires.

8. Connect the microswitch wires.

9. Install combustion chamber in cabinet (See Combustion Chamber Replacement).

## FAN SWITCH REPLACEMENT

### REMOVAL

1. Remove combustion chamber from cabinet (See Combustion Chamber Replacement).

2. Disconnect wires from fan switch shown in Figure 33.

3. Remove two screws holding fan switch.

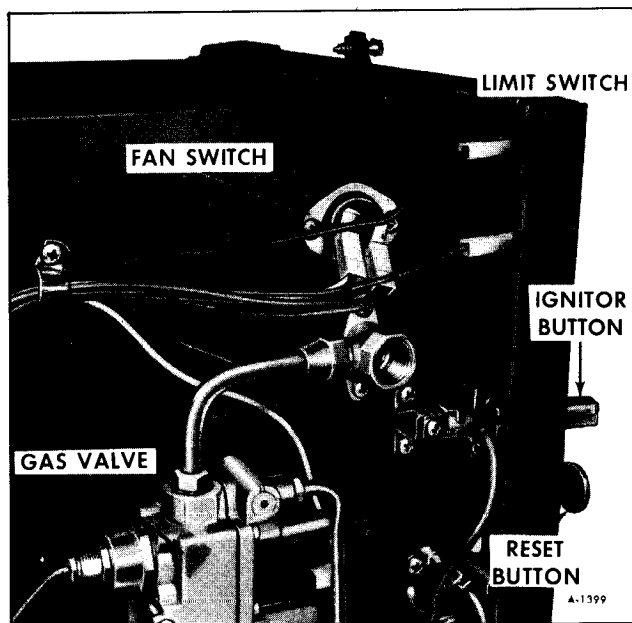

Figure 33-Fan Switch

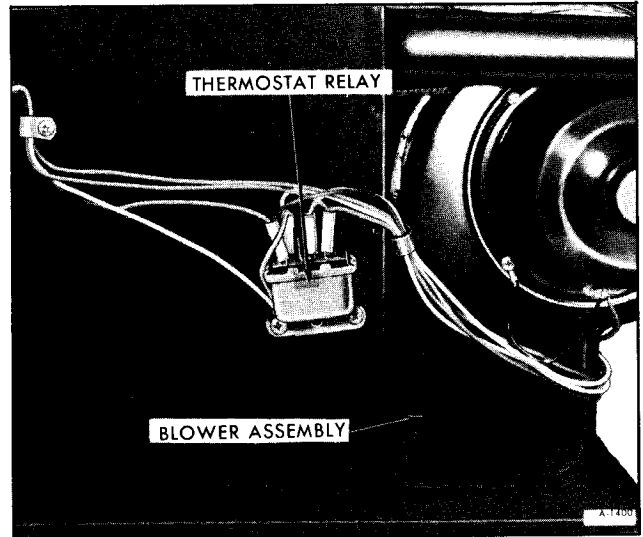

Figure 34-Thermostat Relay

### INSTALLATION

1. Install fan switch on combustion chamber side with two screws (figure 33).

2. Connect wires to fan switch.

3. Install combustion chamber in cabinet (See Combustion Chamber Replacement).

## THERMOSTAT RELAY REPLACEMENT

### REMOVAL

1. Remove combustion chamber from cabinet (See Combustion Chamber Replacement).

2. Disconnect wires at thermostat relay (right side on TYPE I FURNACES, left side on TYPE II FURNACES) (See figure 34).

3. Remove two screws holding thermostat relay.

### INSTALLATION

1. Install thermostat relay on combustion chamber side with two screws.

2. Connect wires to thermostat relay shown in Figure 34.

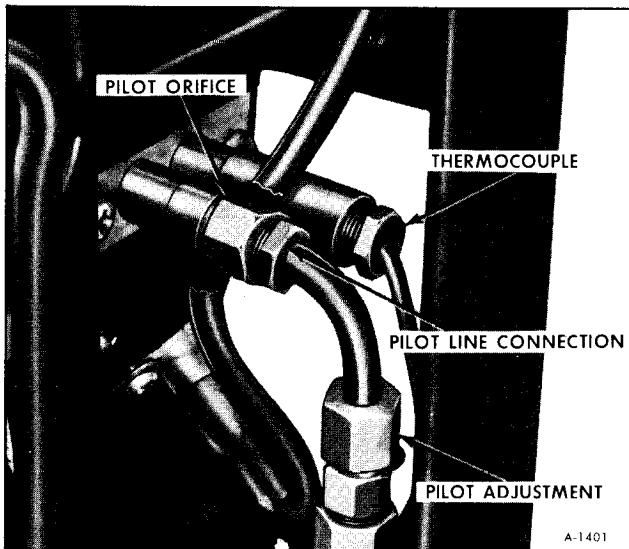

Figure 35—Pilot Orifice

3. Install combustion chamber in cabinet (See Combustion Chamber Replacement).

## THERMOCOUPLE REPLACEMENT

### REMOVAL

1. Remove combustion chamber from cabinet (See Combustion Chamber Replacement).
2. Disconnect thermocouple at pilot burner, and at rear of gas valve, (Refer to figure 20) (pilot safety on NT-22G TYPE I).

### INSTALLATION

1. Install thermocouple at pilot burner and at gas valve.
2. Install combustion chamber in cabinet (See Combustion Chamber Installation).

## PILOT ORIFICE REPLACEMENT

### REMOVAL

1. Remove combustion chamber from cabinet (See Combustion Chamber Replacement).

2. Disconnect pilot line at pilot orifice (See figure 35).

3. Remove the pilot orifice (figure 35).

### INSTALLATION

1. Install pilot orifice in pilot burner.
2. Connect the pilot gas line, at pilot orifice (See figure 35).
3. Install combustion chamber in cabinet (See Combustion Chamber Replacement).

## PILOT BURNER REPLACEMENT

### REMOVAL

1. Remove combustion chamber from cabinet (See Combustion Chamber Replacement).
2. Remove pilot adjustment cover as shown in Figure 36.
3. Disconnect pilot gas line.
4. Remove two screws holding burner as shown in Figure 37.
5. Pull burner clear of combustion chamber.
6. Disconnect thermocouple.

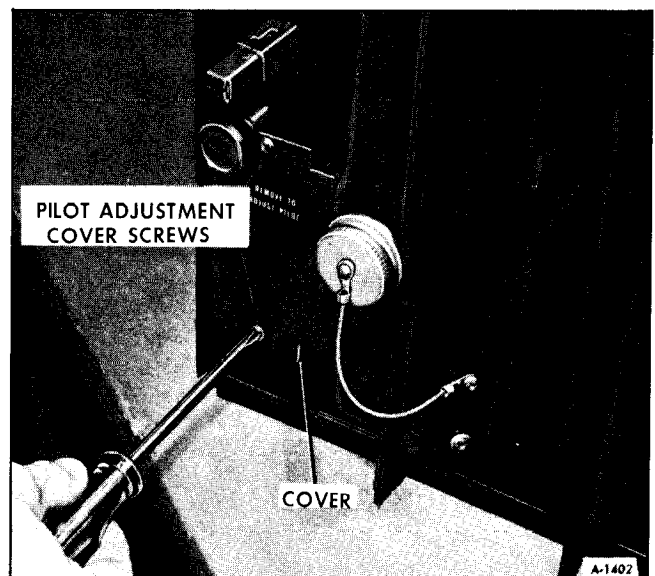

Figure 36—Removing Pilot Adjustment Cover

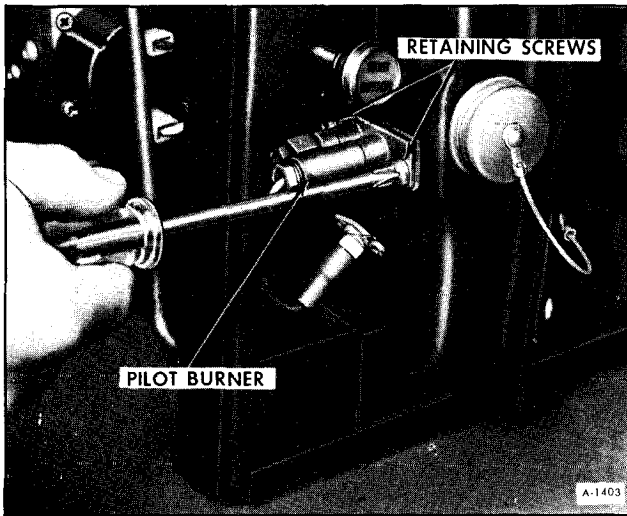

Figure 37—Removing Pilot Burner

## INSTALLATION

1. Connect thermocouple to pilot burner.
2. Position pilot burner in combustion chamber and secure with two screws (figure 37).
3. Connect pilot gas line.
4. Install pilot adjustment cover (figure 36).
5. Install combustion chamber in cabinet (See Combustion Chamber Replacement).

## MAIN BURNER REPLACEMENT (TYPE I FURNACE)

### REMOVAL

1. See "Gas Valve or Pilot Safety Replacement" as described earlier in this section.
2. Once burner, valve(s), and main gas line are removed from combustion chamber as a unit, the burner can be removed (See figure 19).

### INSTALLATION

1. See "Gas Valve or Pilot Safety Replacement" as described earlier in this section.

## MAIN BURNER REPLACEMENT (TYPE II FURNACE)

### REMOVAL

1. Remove combustion chamber from cabinet (See Combustion Chamber Replacement).
2. Disconnect gas line at rear of main burner manifold, as shown in Figure 38.
3. Remove wing nuts from rear of burner compartment (See figure 39).
4. Pull burner assembly out as shown in Figure 40.
5. Disassemble manifold pipe from burner (See figure 20).

### INSTALLATION

1. Assemble main burner to manifold pipe (See figure 20).
2. Install burner assembly in combustion chamber (figure 40).
3. Secure with wing nuts at rear of burner compartment (figure 39).
4. Connect gas line at rear of main burner manifold (figure 38).
5. Install combustion chamber in cabinet (See Combustion Chamber Replacement).

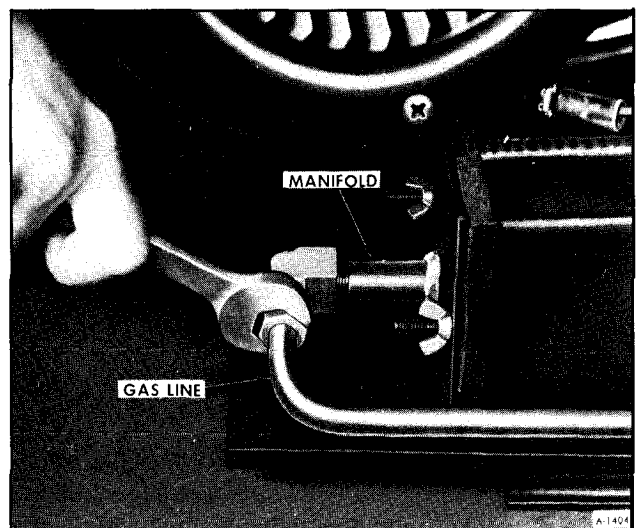

Figure 38—Disconnecting Gas Line at Manifold

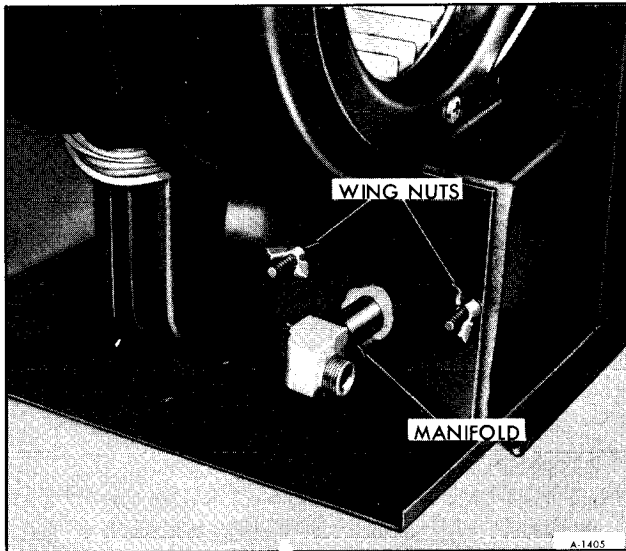

Figure 39—Wing Nuts at Rear of Burner

## MAIN BURNER ORIFICE REPLACEMENT (TYPE I FURNACE)

### REMOVAL

1. See “Gas Valve or Pilot Safety Replacement” as described earlier in this section.
2. Once main burner, valve(s), and main gas line are removed from the combustion chamber as a unit, remove main burner from manifold pipe and replace orifice in end of manifold pipe (figures 19 and 41).

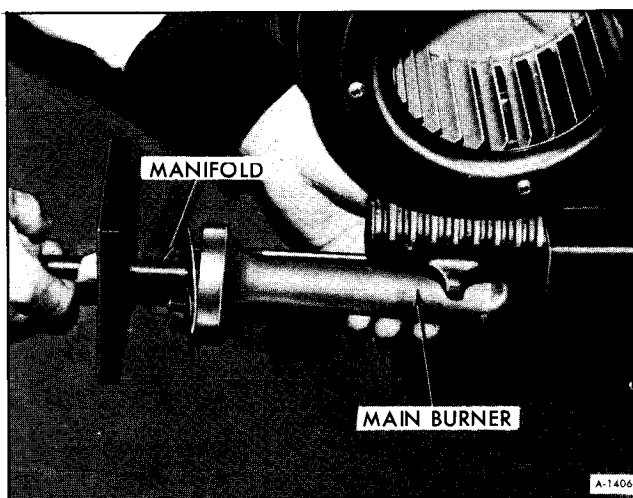

Figure 40—Removing Main Burner

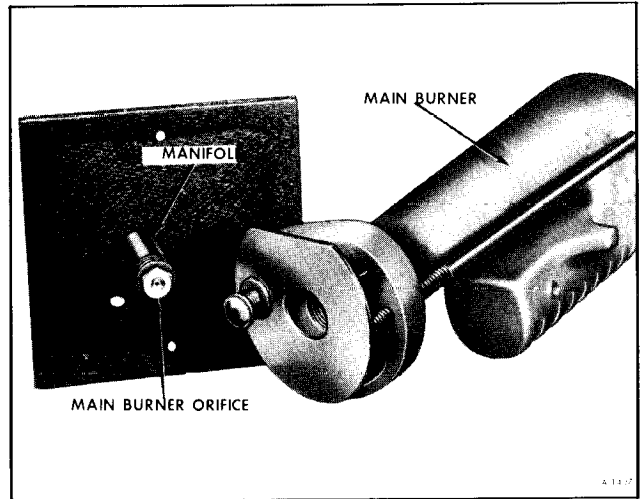

Figure 41—Main Burner Orifice

### INSTALLATION

1. See “Gas Valve or Pilot Safety Replacement” as described earlier in this section.

## MAIN BURNER ORIFICE REPLACEMENT (TYPE II FURNACE)

### REMOVAL

1. Remove combustion chamber from cabinet (See Combustion Chamber Replacement).
2. Disconnect gas line at rear of main burner manifold (See figure 38).
3. Remove wing nuts from burner compartment door (figure 39).
4. Pull burner assembly out (figure 40).
5. Disassemble manifold pipe from burner and remove burner orifice. See Figures 41 and 20.

### INSTALLATION

1. Install main burner orifice in the end of the manifold pipe (figures 20 and 41).
2. Assemble main burner and manifold pipe. See Figure 20.

3. Install burner assembly in combustion chamber (figure 40).

4. Secure burner assembly with two wing nuts (figure 39).

5. Connect gas line at rear of main burner manifold (figure 38).

6. Install combustion chamber in cabinet (See Combustion Chamber Replacement).

## LIMIT SWITCH REPLACEMENT (TYPE I FURNACE)

### REMOVAL

1. Remove combustion chamber from cabinet (See Combustion Chamber Replacement).

2. Disconnect two wires from rear of limit switch located at lower front corner (figure 42).

3. Remove two screws holding switch.

### INSTALLATION

1. Install limit switch and secure with two screws (figure 42).

2. Connect wires to switch.

3. Install combustion chamber in cabinet (See Combustion Chamber Replacement).

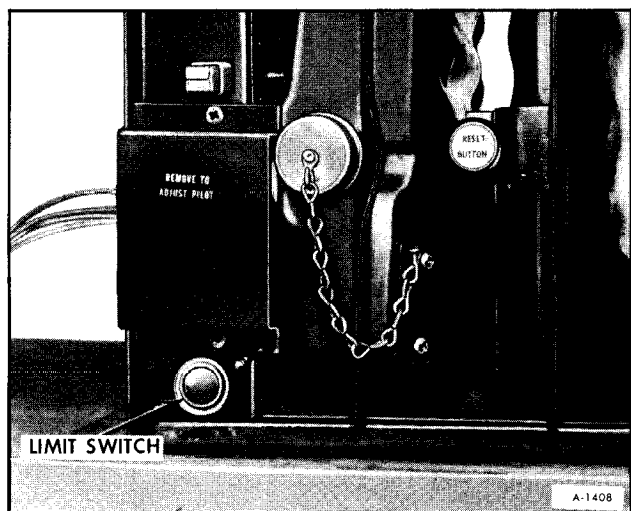

Figure 42—Type I Furnace Limit Switch

## LIMIT SWITCH REPLACEMENT (TYPE II FURNACE)

### REMOVAL

1. Remove cabinet front (one screw at top of cabinet front).

2. Disconnect two wires at rear of limit switch located at upper front corner (See figure 43).

3. Remove two screws holding limit switch.

### INSTALLATION

1. Install limit switch and secure with two screws (figure 43).

2. Connect wires to rear of switch.

3. Install cabinet front, making sure it is properly seated in all grooves (1 screw at top of cabinet front).

## WALL THERMOSTAT REPLACEMENT

### REMOVAL

1. Turn thermostat to "OFF" position, as shown in Figure 7.



Figure 43—Type II Furnace Limit Switch

2. Remove thermostat cover.
3. Remove two screws holding thermostat body to wall.
4. Disconnect two wires.

## INSTALLATION

1. Connect wires to thermostat.
2. Secure thermostat body to wall with two screws.
3. Install thermostat cover.

# ON VEHICLE ADJUSTMENTS

## PILOT ADJUSTMENT

To adjust the furnace pilot it is necessary to gain access first through the access door and then by removing the pilot adjustment cover directly under the ignitor button (2 screws). The pilot gas line accessible at this point will have the pilot adjustment located in the line as shown in Figure 44.

It is important that the pilot flame be the proper size. Unlike most heating equipment, in this furnace too large a flame is a common cause of pilot outage due to lack of sufficient air. It should be just high enough to envelop the thermocouple. If the pilot flame cannot be adjusted to this point or is yellowish in color, replace the pilot orifice.

## BURNER ADJUSTMENT

After the pilot is lit, the furnace is ready for

adjustment and observation of the main burner and pilot flame.

To adjust primary air to the main burner, it is necessary to gain access the same way as with lighting the pilot. The small sheet metal cover found just below and to the right of the lighter opening must be removed. Behind the cover is a slotted screw head. With a screwdriver, turn screw head counterclockwise for less primary air and clockwise for more primary air (Refer to figure 45). A symptom of too much primary air will be a howling or screeching noise when the burner is on (reduce air to correct). A symptom of too little primary air will be sooting on the exterior vent and a distinct yellow and floating flame (increase air to correct). A slight trace of orange should remain at the tip of the burner flame—this is a sign of correct adjustment.

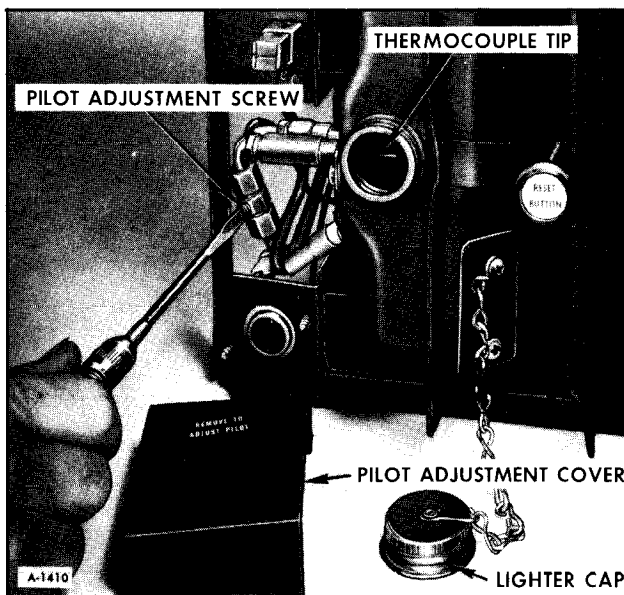

Figure 44—Adjusting Pilot

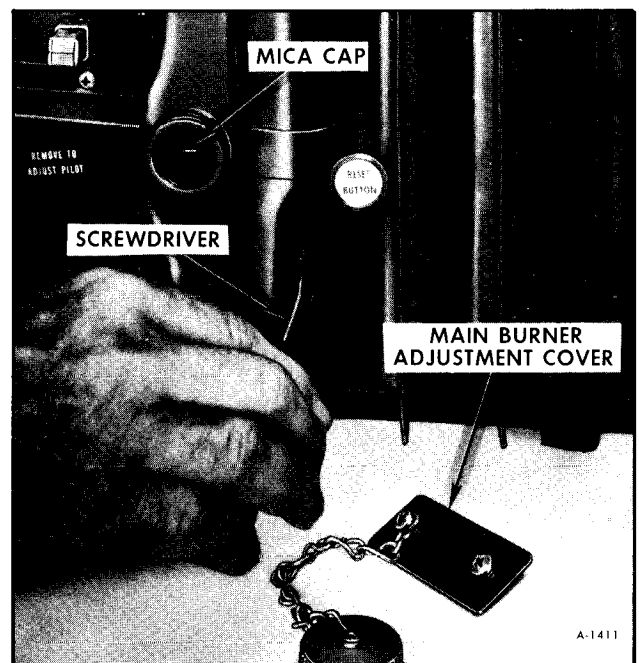

Figure 45—Adjusting Main Burner



# SECTION 24H

## RANGE / OVEN

### GENERAL INFORMATION

With the exception of the range pilot and one burner, both range/oven models used in the Motor Home are similar and are designed for operation with liquid petroleum gas (L.P.G.) only (See figure 1 figure 2). Never attempt to operate these units with any other type of fuel.

The range/oven in the Motor Home differs from a conventional residential range in as much as it is equipped with a thermostat control where you can shut-off the gas to the pilot(s) when traveling. Also clips are provided for the top burner grates and oven rack to prevent rattles and dislodgement while the vehicle is in motion.

#### OPERATION

1. Turn on hood vent fan.
2. Be sure all knobs are in the "OFF" position.

The oven thermostat should be in the "PILOTS OFF" position.

3. Depress the oven thermostat and turn to the "OVEN OFF" position.
4. Lift the cook top panel and light range burner



Figure 1—Three Burner Range/Oven

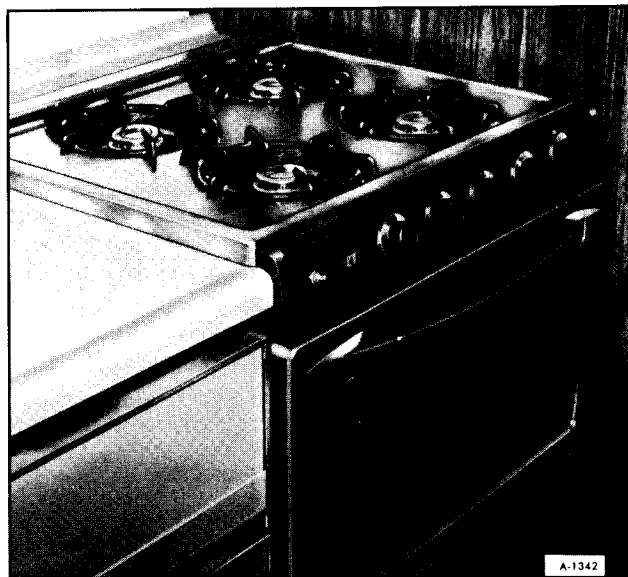

Figure 2—Four Burner Range/Oven



pilot with a match (Four burner unit only).

5. Open the oven door and light the oven pilot with a match. A small flame will be noted at the top of the pilot burner. Upon the initial light-up it may take a minute or so to clear the air from the lines.

6. To light range burner push desired burner knob in and turn gas on all the way to get gas to the burner. As soon as burner lights, flame may be reduced to the desired height. Note on three burner unit each burner must be lit with a match.

7. To light oven burner depress and turn the thermostat dial to the desired temperature setting.

### SEQUENCE OF NORMAL OPERATION

1. On the range burners with the pilots lit, it will take 3 to 5 seconds for the burner to come on after the burner control is turned from the "OFF" position to the full on position.

2. On the oven burner with the pilot lit, you will get a secondary pilot immediately upon turning the oven thermostat control to the desired temperature setting - i.e. the pilot will burn larger and brighter at this time. Approximately 10-15 seconds later the main burner will ignite.

## RANGE / OVEN TROUBLE DIAGNOSIS

Problem	Possible Cause	Correction
No oven burner ignition.	1. Gas supply. 2. Pilot outage. 3. Oven Thermostat Control – You can tell that the thermostat is defective if you fail to get a secondary pilot immediately upon turning thermostat to the desired setting. (SEE "SEQUENCE OF NORMAL OPERATION") 4. Oven Safety Valve – This can be determined as faulty if you do get a secondary pilot, upon setting the thermostat control to the desired temperature, but no oven ignition.	1. Be sure main gas valve/s are open and there is fuel in the tank. 2. Check to see that pilot is lit. 3. Replace Oven Thermostat Control. 4. Replace Oven Safety Valve.
No range burner ignition.	1. Gas supply. 2. Pilot outage. (If so equipped). 3. Burner ports are clogged. 4. Burner control valve faulty.	1. Be sure main gas supply is on. 2. Check to see that pilot is lit. Also, pilot may be improperly adjusted. 3. Make sure burner ports are not clogged. 4. Replace burner valve.

Problem	Possible Cause	Correction
Pilot outage.	<ol style="list-style-type: none"> <li>1. Gas supply.</li> <li>2. Air in the gas lines.</li> <li>3. Pilot blowout.</li> <li>4. Plugged orifice.</li> </ol>	<ol style="list-style-type: none"> <li>1. Be sure main gas valve(s) are open and there is fuel in the tank.</li> <li>2. Bleed lines by holding match to burner and turning gas to that burner on fully.</li> <li>3. Check for excessive drafts.</li> <li>4. Carefully clean orifice with toothpick.</li> </ol>
Noisy when traveling.	<ol style="list-style-type: none"> <li>1. Broiler pan.</li> <li>2. Range burner grates.</li> <li>3. Oven rack.</li> <li>4. Cook top.</li> <li>5. Oven bottom assembly.</li> </ol>	<ol style="list-style-type: none"> <li>1. It may be desirable to store pan in towel drawer adjacent to the oven.</li> <li>2. Be sure grates are properly clipped.</li> <li>3. Be sure rack is properly positioned in its clips.</li> <li>4. Check to make sure top is properly positioned.</li> <li>5. Check that oven bottom assembly is positioned and clipped.</li> </ol>
Oven burner ignites as soon as thermostat control is turned to desired temperature.	<ol style="list-style-type: none"> <li>1. Oven Safety Valve – If there is not a 10 to 15 second delay before oven burner ignites after the desired oven temperature is set, the Oven Safety Valve is faulty.</li> </ol>	<ol style="list-style-type: none"> <li>1. Replace Oven Safety Valve.</li> </ol>

## RANGE / OVEN COMPONENT DISASSEMBLY PROCEDURES

**WARNING: BEFORE PERFORMING ANY REMOVAL OR DISASSEMBLY PROCEDURES, BE SURE THE LP GAS IS TURNED COMPLETELY OFF AT THE LP GAS TANK.**

**NOTE:** To gain space when working in and/or on range/oven (figures 3 or 4) it is often desirable to remove the oven door.

### OVEN DOOR REPLACEMENT

1. Place screwdrivers (awls, nails, etc.) through

holes in oven door hinge while door is open. (figure 4).

2. Lift door (as if to close) and disengage hinges at door (See figure 5).

3. Remove door.

4. To reinstall reverse procedure.

### OVEN THERMOSTAT CONTROL REPLACEMENT

1. Remove oven door.

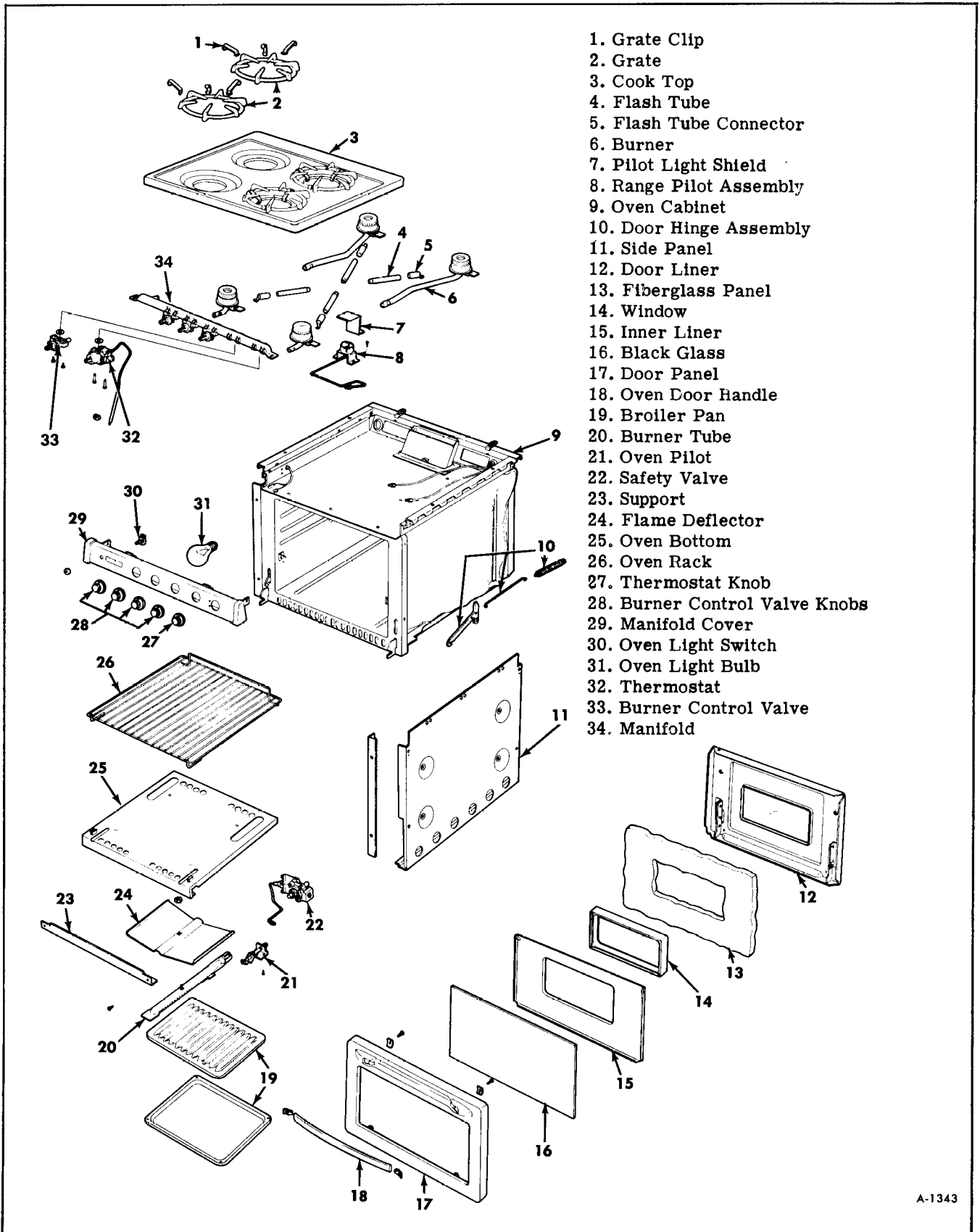

Figure 3—Four Burner Range/Oven Components

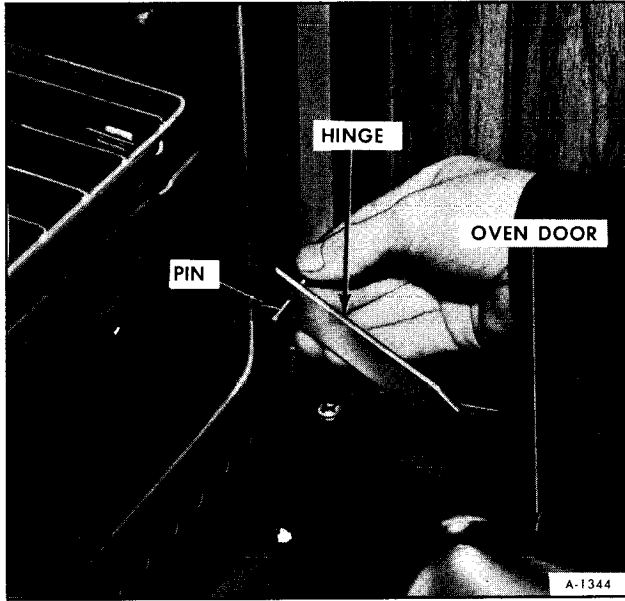

Figure 4—Inserting Pin In Door Hinge

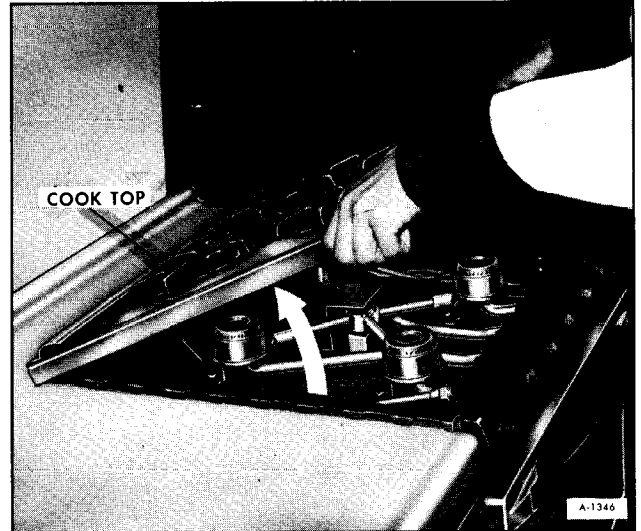

Figure 6—Cook Top Removal

2. Remove cook top and grates (See figure 6).
3. Pull control knobs off.
4. Remove manifold cover by disconnecting light switch, (if so equipped) and removing six screws (two at each side and two at bottom) (See figures 7 and 8).
5. Disconnect gas lines from rear of thermostat control as shown in Figure 9.

6. At the top of the oven compartment, remove the clip holding the thermal sensing element and carefully feed this element up through the hole in the top of the oven compartment (figure 10).

7. Disconnect the main fuel line from the manifold and remove the two screws holding manifold in place (one at each end) (figure 11 and figure 12).

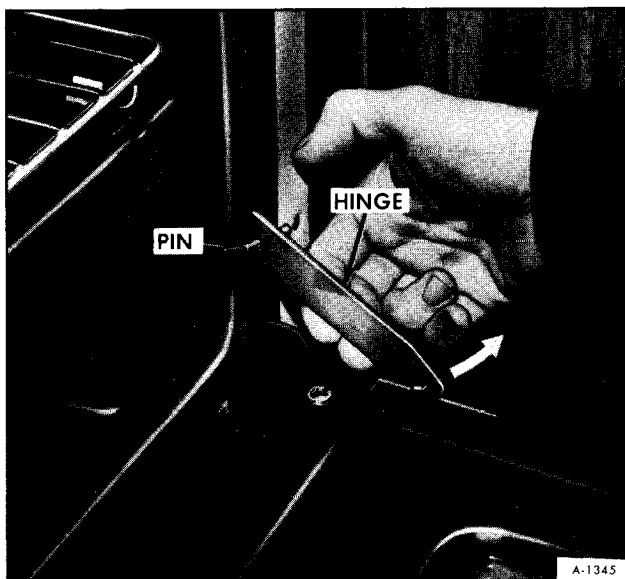

Figure 5—Disengaging Door Hinge

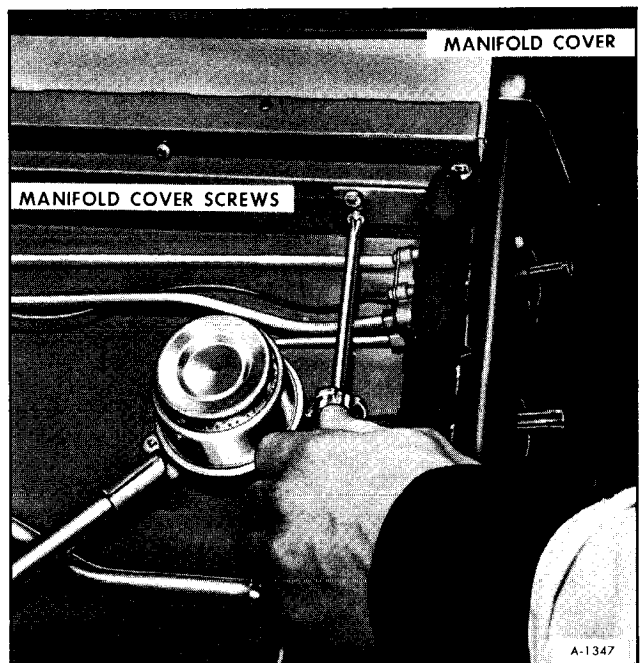

Figure 7—Removing Manifold Cover Screws (Upper)

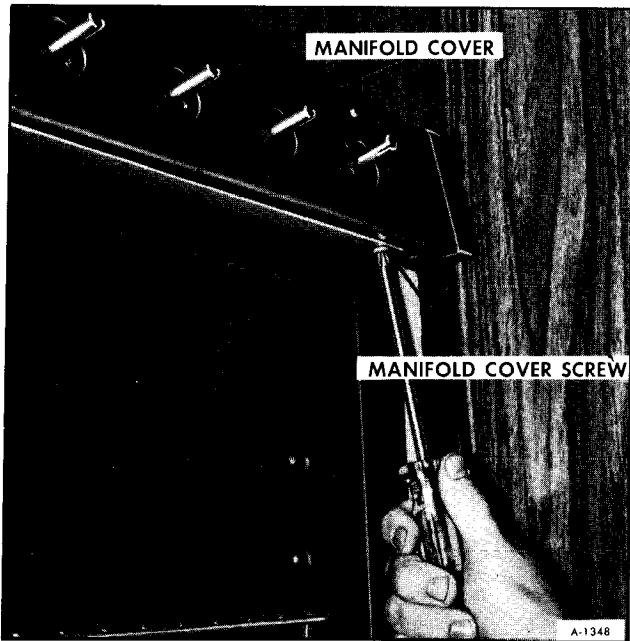

Figure 8—Removing Manifold Cover Screws (Lower)

8. Move manifold forward and disengage burner valves from burner tubes.

9. Turn manifold over and remove the two screws (figure 13) holding thermostat control and remove it from manifold.

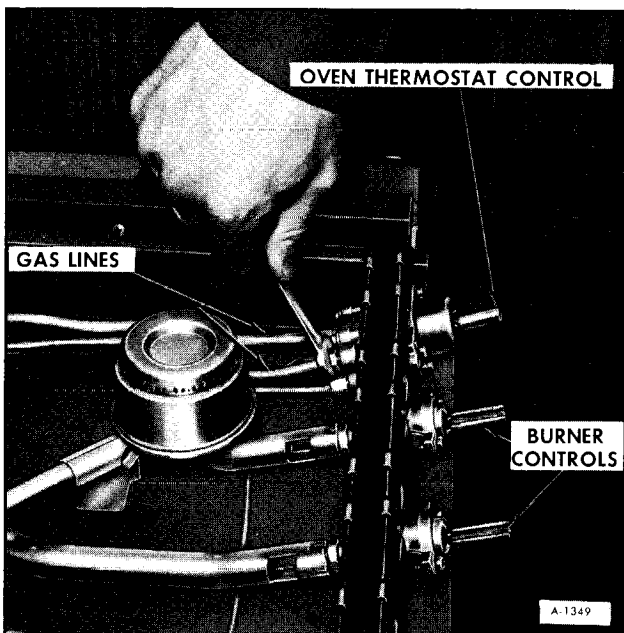

Figure 9—Disconnecting Gas Lines From Rear Of Thermostat

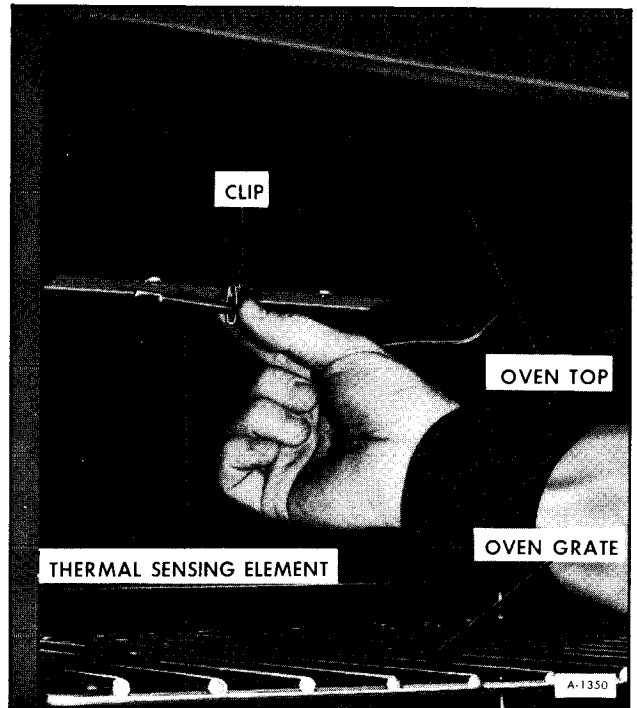

Figure 10—Removing Thermal Sensing Element

10. Replace thermostat control and gasket and reassemble by reversing procedure.

### OVEN SAFETY VALVE REPLACEMENT

1. Remove oven door (See “Oven Door Replacement”).

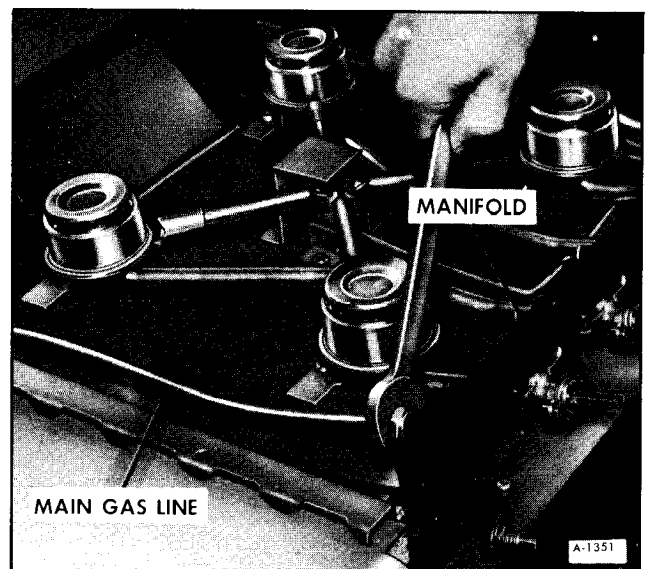

Figure 11—Disconnecting Main LP Gas Line

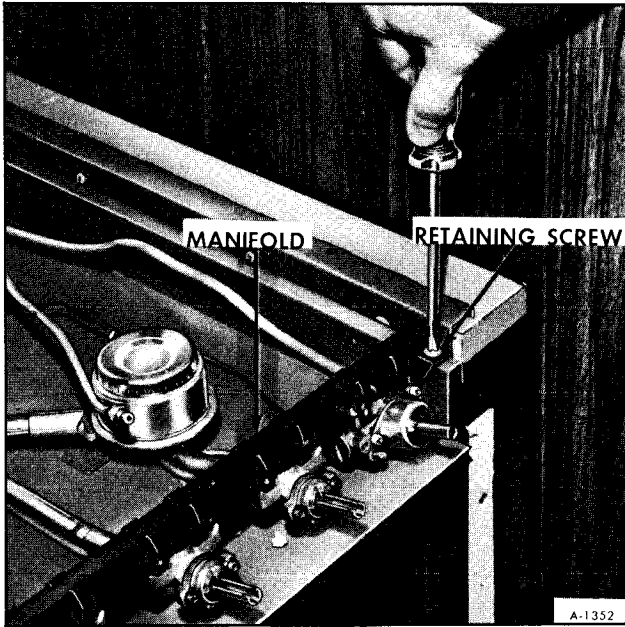

Figure 12—Removing Manifold Retaining Screws

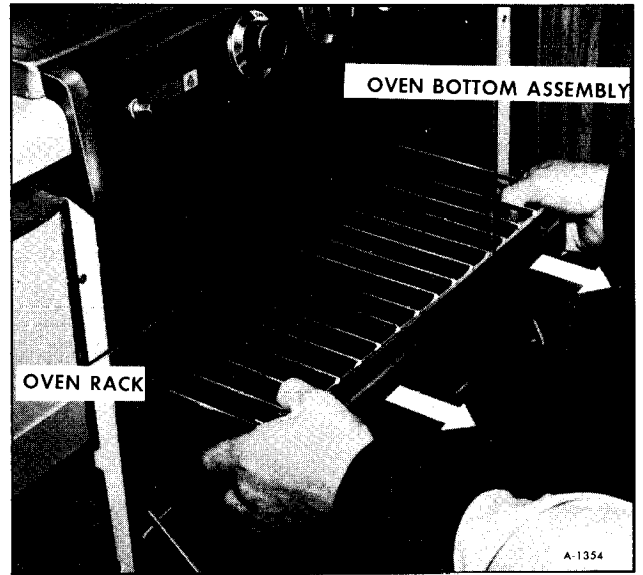

Figure 14—Removing Oven Bottom Assembly

2. Remove oven rack.
3. Remove oven bottom assembly by pulling outward (See figure 14).
4. Remove flame deflector (figure 15) from top of burner tube (held with one nut).

5. Disconnect the two gas lines, one at the oven pilot and one at the safety valve (See figures 16 and 17).

6. Remove the two nuts holding the safety valve to the oven back wall as shown in Figure 18.

7. Remove the screw from the front of the burner tube (figure 19).

8. Gently remove the burner tube and the safety

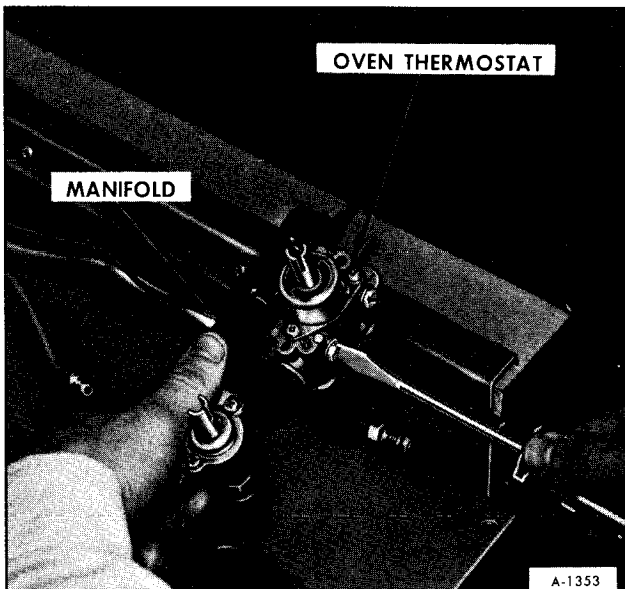

Figure 13—Removing Thermostat From Manifold

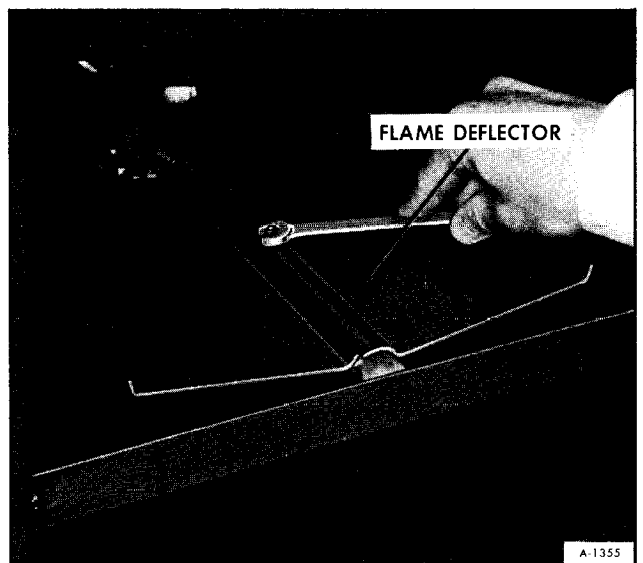

Figure 15—Removing Flame Deflector

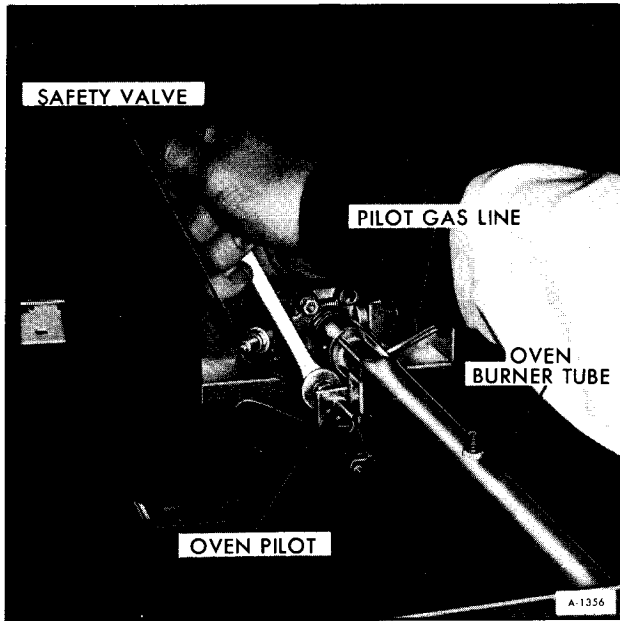

Figure 16—Disconnecting Gas Line at Oven Pilot

valve as one unit being careful not to break the capillary tube connected from the safety valve to the burner tube (See figure 20).

9. Loosen screw holding the capillary tube bulb to the burner tube and disconnect capillary tube.

10. Replace oven safety valve and reassemble by reversing procedure.

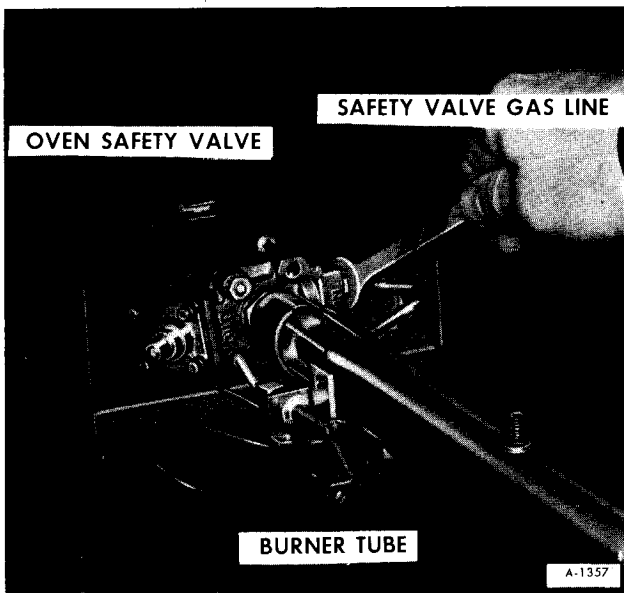

Figure 17—Disconnecting Gas Line at Safety Valve



Figure 18—Removing Nuts Holding Safety Valve

### RANGE BURNER CONTROL VALVE REPLACEMENT

1. Remove oven door, (if desired).
2. Remove cook top and grates (See figure 6).
3. Remove control knobs.

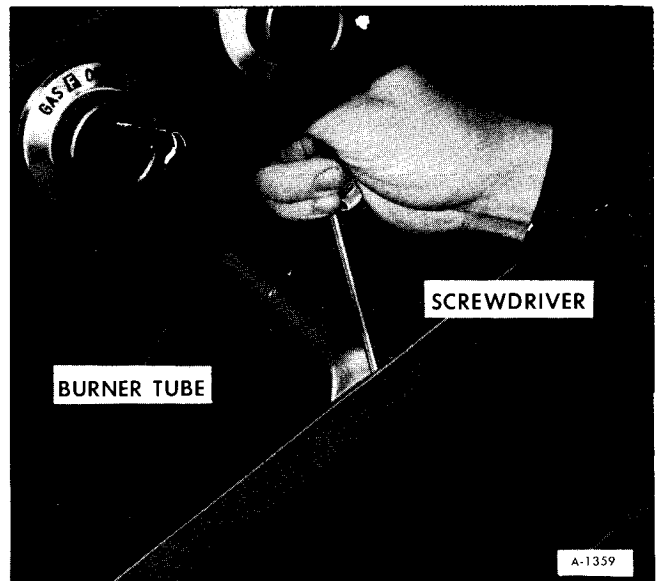

Figure 19—Removing Retaining Screw at Front of Burner Tube

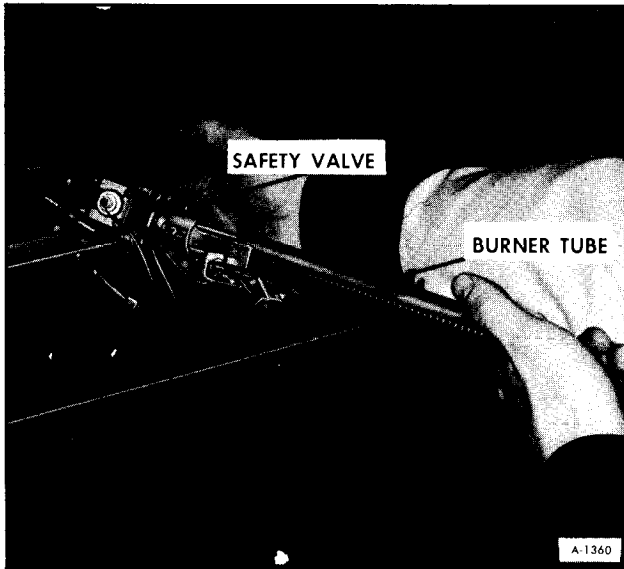

Figure 20—Removing Burner Tube and Safety Valve as a Unit

4. Remove manifold cover by disconnecting the light switch (if so equipped), and removing the six screws holding the cover (two at each side and two at the bottom of the cover) (See figures 7 and 8).

5. Disconnect the main fuel line from the manifold and remove the two screws holding the manifold in place (one at each end) as shown in Figures 11 and 12.

6. Move manifold forward and disengage burner control valves from burner tubes.

7. Tilt manifold upward enough to make the

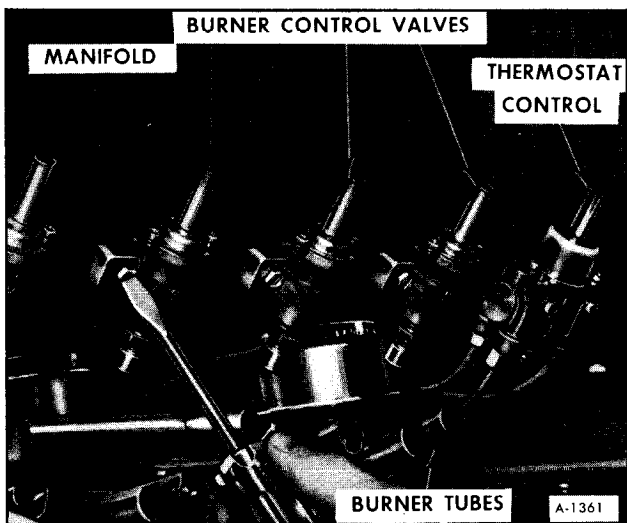

Figure 21—Removing Burner Control Valve

screws at the bottom of the burner control valves accessible (See figure 21).

8. Remove the two screws holding the affected valve and remove it from manifold.

9. Replace burner control valve and gasket and reassemble by reversing procedure.

## TOP BURNER REPLACEMENT

Should it become necessary to remove the top burners to clean or replace them, perform the following:

1. Remove cook top and grates (See figure 6).

2. Remove single screw holding burner head to range top (figure 22).

3. If range is equipped with range pilot, unhook flash tube from burner.

4. Disengage burner and burner tube from burner control valve (See "Care and Cleaning" for cleaning instructions).

5. To install top burner reverse the above procedure.

## RANGE/OVEN UNIT REPLACEMENT

Only in rare instances will it become necessary to remove the complete Range/Oven from the cabinet module. Should this become necessary it's possible by:

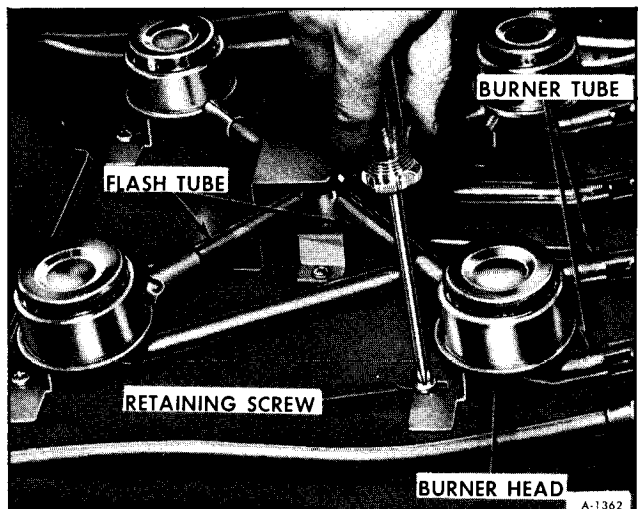

Figure 22—Top Burner Removal



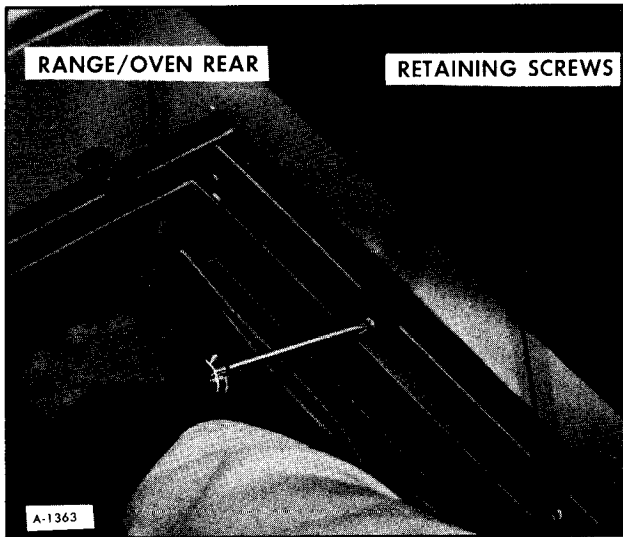

Figure 23—Removing Upper Range/Oven Anchor Screws

1. Removing cook top and grates.
2. Disconnect gas line from manifold (figure 11).
3. Remove the two screws through each upper side wall that hold unit to the cabinet top (figure 23).
4. Open oven door and remove two screws from each side of the oven front trim strips that hold unit to cabinet front (figure 24).
5. If Range/Oven is equipped with an oven light, move the unit forward far enough to enable you to reach behind unit and disconnect the 12 volt wire.
6. Remove unit from the cabinet module.
7. To install unit reverse the above procedure.

### OVEN DOOR HINGE REPLACEMENT

Should it become necessary to service the oven door hinges this can be accomplished by:

1. Remove Range/Oven unit from cabinet module (See "Range/Oven Unit Replacement").

## CARE AND CLEANING

### GENERAL

Regular cleaning with warm detergent solution and a soft cloth will keep your range looking bright and new. This should be done as soon as range cools.

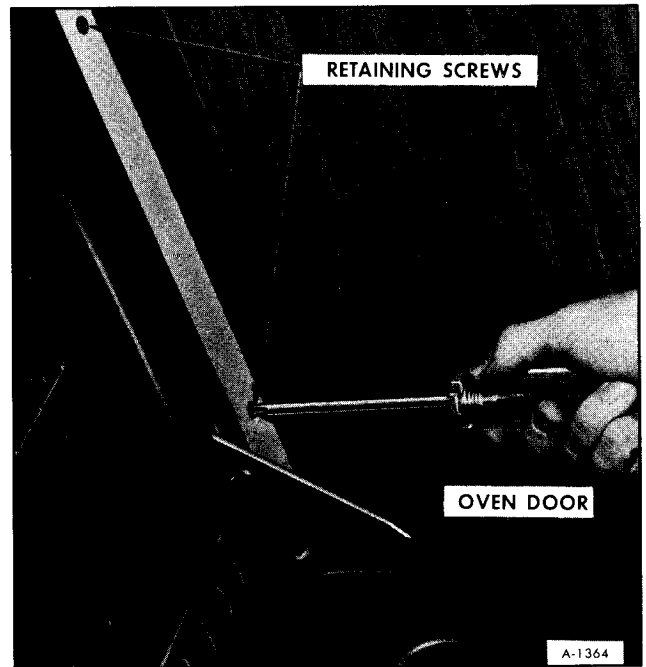

Figure 24—Removing Front Range/Oven Anchor Screws

2. Remove the eleven screws holding the outer oven side panel (See figure 3).
3. Remove outer side panel and lift insulation. At this point the oven door hinge and spring are accessible for servicing.
4. To install reverse the above procedure.

### OVEN DOOR GLASS REPLACEMENT (FOUR BURNER UNIT ONLY)

1. Remove oven door from Range/Oven unit (See "Oven Door Replacement").
2. With oven door face down on a bench remove the four screws from inner door panel.
3. With oven door disassembled replace glass (See figure 3).
4. Install oven door glass by reversing the above procedure.

*Porcelain Enamel* – Wipe surface clean immediately. Do not use metal scouring pads or cleanser containing grit or acid.

*Chrome* – To keep the mirror-bright finish, wipe

with damp cloth and dry thoroughly. Stubborn stains may be removed with lemon juice, vinegar or chrome polish.

*Glass* – Wipe cooled glass with detergent and hot water. Rinse and polish with soft cloth.

## BROILER PAN

Remove from oven immediately after use. Drain fat. Sprinkle rack with detergent and cover with wet paper towels and let soak, before washing in hot soapy water.

## OVEN

Clean as soon as possible after use and when the oven is cool. Grease splatters that are allowed to

become hard and baked on are very difficult to remove.

Care must be taken to avoid bending the tube clipped to the top of the oven. This is the thermal sensing element and could cause a variation between the oven temperature and dial setting.

If oven cleaners are used, be sure to rinse the tube thoroughly and wipe dry.

## TOP BURNERS

Top burners may be cleaned with a detergent solution. If any burner port should become clogged, clean with a toothpick. Never use pins or other metal objects to clean the ports, as they may become enlarged. If the burner is washed in a sink, dry immediately by shaking off all excess water and lighting the burner until all water has evaporated.

# ON-VEHICLE ADJUSTMENTS

## PILOT ADJUSTMENT

The oven pilot is preadjusted and cannot be adjusted.

The range burner pilot (if so equipped) should burn with a blue flame having a slight yellow tip. The tip of the flame should extend to approximately the top of the lighter body. The adjustment screw is located behind the oven thermostat control dial. To adjust pilot remove dial and insert small screwdriver through the hole (figure 25). Rotate adjustment screw as required.

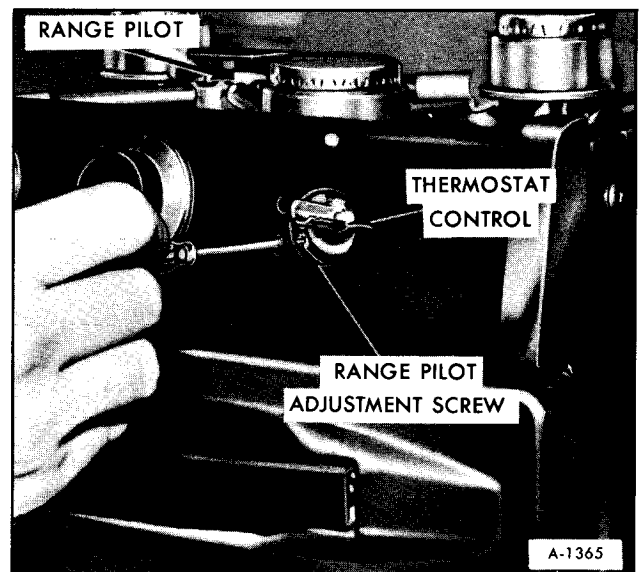

Figure 25—Adjusting Range Pilot



# SECTION 24J

## LIVING AREA WATER SYSTEM

The contents of this section are listed below:

SUBJECT	PAGE NO.
General Description.....	24J- 1
Trouble Diagnosis .....	24J- 3
On-Vehicle Adjustment .....	24J- 4
Water Tank .....	24J- 5
Water Tank Sending Unit.....	24J- 6
Water Pump.....	24J- 6
Water Heater .....	24J- 9
Bathroom Sink Faucet.....	24J-11
Shower Head and Hose.....	24J-13
Galley Sink.....	24J-13
Water Purifier (Optional) .....	24J-15
City Water Connection .....	24J-16
Water Lines and connections .....	24J-17

### GENERAL DESCRIPTION

Living area water system (figure 1) is supplied by either a demand water pump or by a city-water hook-up. There is no pressure tank in the system. When a faucet is opened and the water pump switch is on, or toilet is flushed, the pump will come on when the water line pressure drops below 20 PSI. When the faucet is closed the pump will run long enough to raise the line pressure to 30 PSI, then it will shut-off automatically.

A 40 gallon water tank stores water to be drawn out by the water pump. The tank can be filled only through its own fill tube connection.

A connection is provided to hook-up to a city water supply. When this is done the water pump acts as a check valve and water does not enter the water tank.

The water lines are made of copper and are connected with compression flared, or sweat fittings.

There are five (5) drain valves standard on the vehicle. There are six (6) drain valves on vehicles equipped with an electric (recirculating) toilet.

These valves are used to drain the water system (See figure 1).

They are located at the:

1. water holding tank.
2. water pump pressure line.
3. water heater.
4. electric toilet (if equipped).
5. hot water line behind galley sink.
6. cold water line behind galley sink.

**MODEL 230**

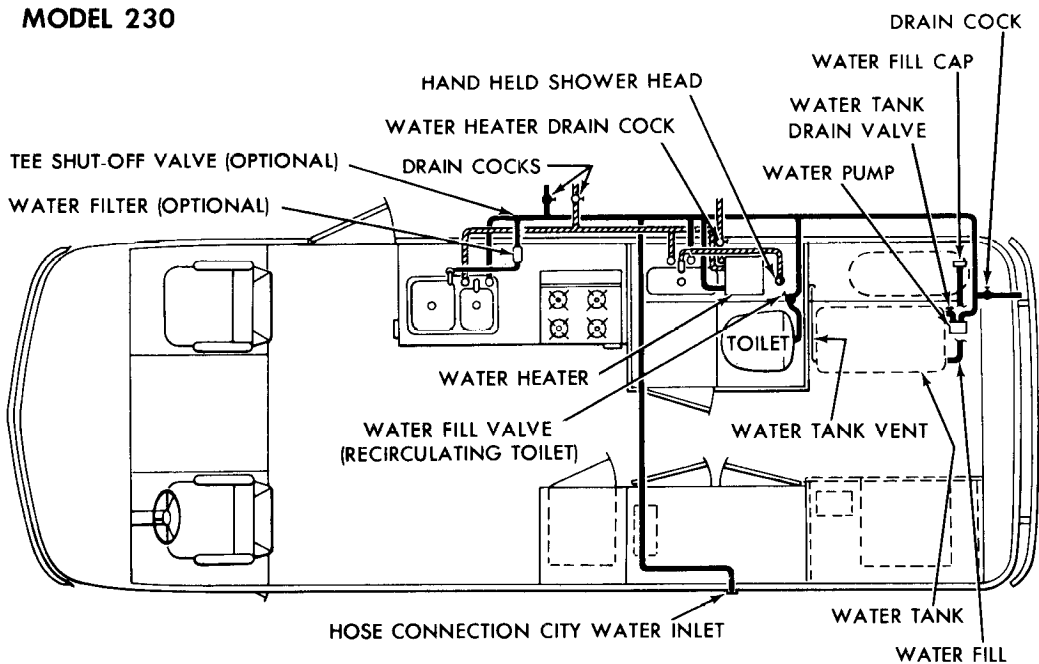

**MODEL 260**

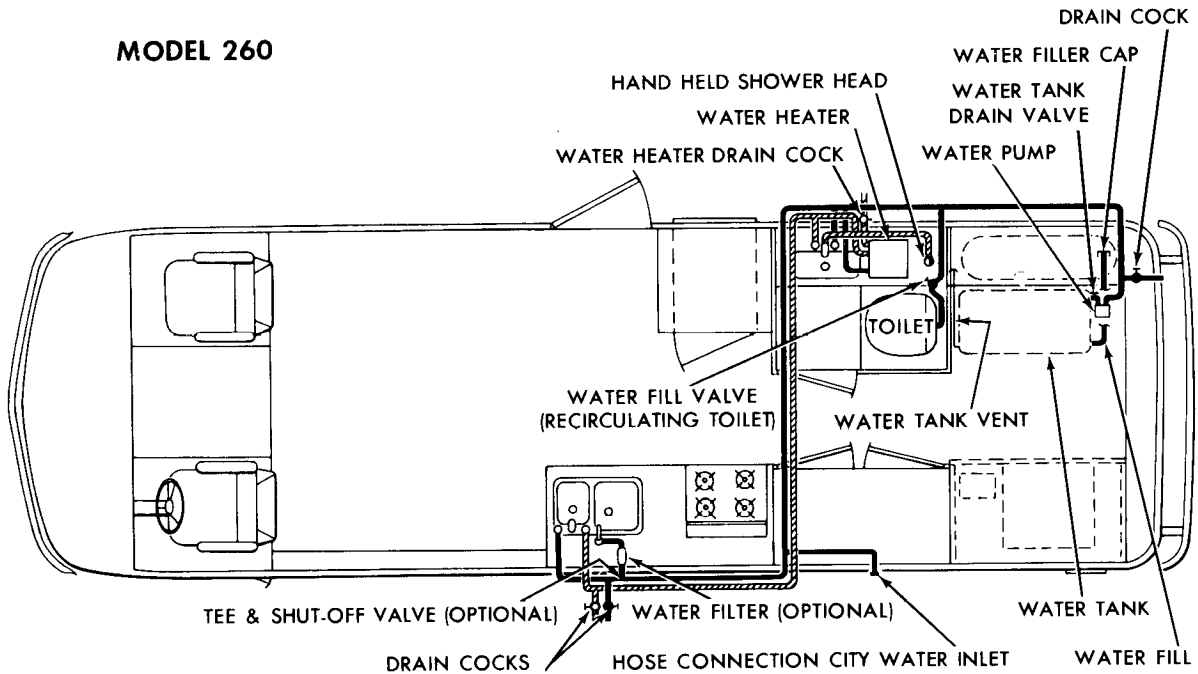

— COLD WATER

▨ HOT WATER

Figure 1—Living Area Water System Schematic

## TROUBLE DIANOSIS

Problem	Possible Cause	Correction
No water.	<ol style="list-style-type: none"> <li>1. Water pump switch not on.</li> <li>2. No water in tank.</li> <li>3. Drain cocks open.</li> <li>4. Pump belt broken.</li>   <li>5. Insufficient or no voltage at pump.</li>   <li>6. Faulty pressure switch on pump.</li> <li>7. Pump motor burned out.</li> <li>8. Pump is not priming itself or doesn't build up enough pressure to shut-off.</li> </ol>	<ol style="list-style-type: none"> <li>1. Turn on switch.</li> <li>2. Fill tank.</li> <li>3. Close all drain locks.</li> <li>4. Replace belt. Refer to "Water Pump Belt Replacement" later in this section. Tension as shown in "On-Vehicle Adjustment-Water Pump Belt", later in this section.</li> <li>5. Check fuse panel, replace fuse if required. Check for shorts. Check living area battery for charge. Charge if necessary. Check voltage at water pump wall switch. Voltage at the switch and not at the pump indicates a possible loose or incorrect connection or broken wire between switch and pump. Correct as necessary.</li>   <li>6. Check switch. Refer to "Pressure Switch" later in this section.</li> <li>7. Replace motor.</li> <li>8. Remove pump, dismantle and inspect check valve assemblies. Refer to "Water Pump-Disassembly" later in this section.</li> </ol>
No or not enough hot water.	<ol style="list-style-type: none"> <li>1. Water Heater Switch not on.</li> <li>2. Tank has overheated.</li>   <li>3. Water heater thermostat not properly set.</li>   <li>4. Low voltage.</li> <li>5. Incorrect wiring.</li>   <li>6. Heater element burned out.</li>   <li>7. Thermostat burned out.</li>   <li>8. Water pre-heat hose (if equipped) pinched.</li> </ol>	<ol style="list-style-type: none"> <li>1. Turn on switch.</li> <li>2. Remove metal cover and push reset button.</li> <li>3. Check thermostat and reset if necessary. Refer to "On-Vehicle Adjustmen-Water Heater" later in this section.</li> <li>4. Check source and correct as necessary.</li> <li>5. Check wire connections and correct as necessary.</li> <li>6. Replace element. Refer to "Water Heater-Removal" later in this section.</li> <li>7. Replace thermostat. Refer to "Water Heater-Removal" later in this section.</li> <li>8. Check pre-heat hose routings, correct as required.</li> </ol>
Leaking water system.	<ol style="list-style-type: none"> <li>1. Loose on incorrect fittings.</li> </ol>	<ol style="list-style-type: none"> <li>1. Locate leak, determine cause and correct.</li> </ol>

Problem	Possible Cause	Correction
Water tank gauge at monitor panel does not operate (if equipped).	1. Defective sending unit or monitor panel gauge.	1. Refer to "Living Area Electrical" earlier in this manual. Refer to "Water Tank-Sending Unit" later in this section.

## ON VEHICLE ADJUSTMENT

### WATER PUMP BELT

To obtain maximum life from the water pump belt it should be adjusted to obtain 1/8" deflection as shown in Figure 2.

Loosen motor mounting nuts, tension belt properly and tighten nuts.

### WATER PUMP PRESSURE SWITCH

Both the cut-on and cut-off points may be adjusted after removing the pressure switch cover. To effectively do this, remove the four (4) pump assembly hold down screws and reposition pump for better

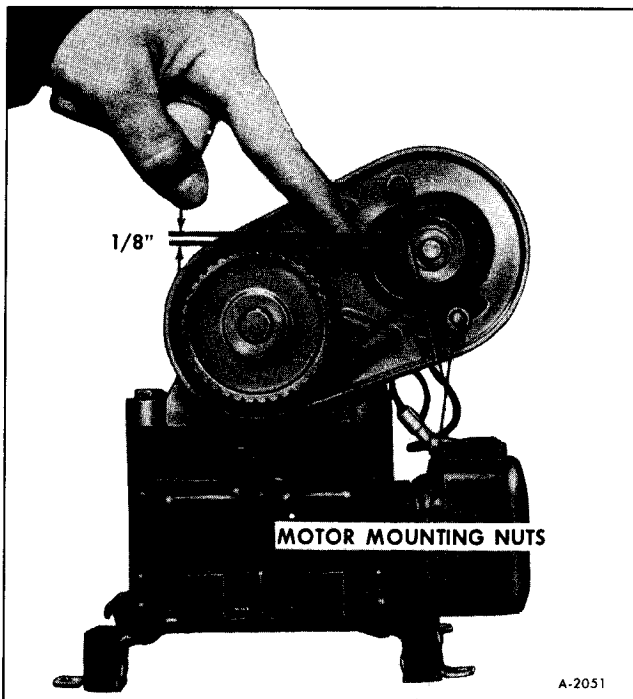

Figure 2-Water Pump Belt Tension

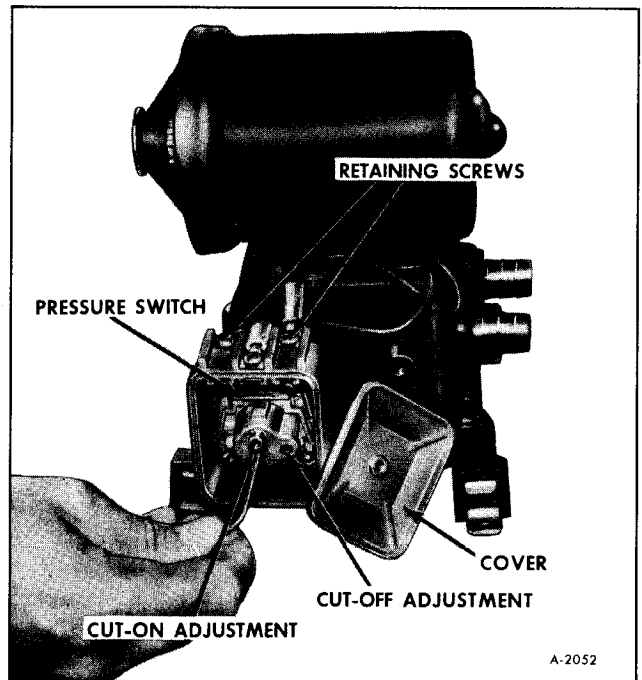

Figure 3-Adjusting Cut-On and Cut-Off at Pressure Switch.

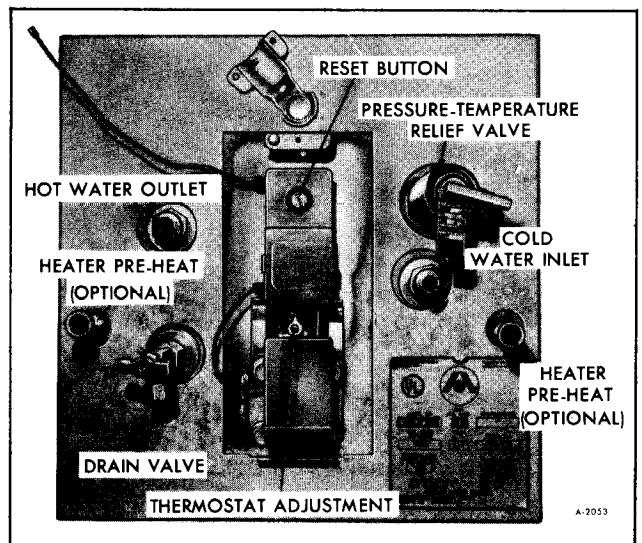

Figure 4-Water Heater

access. With the cover removed turn the adjusting screws shown in Figure 3, as required to obtain a cut-on setting of 20 PSI and a cut-off setting of 30 psi.

## WATER HEATER THERMOSTAT

**NOTE:** Recent production water heaters are equipped with a non-adjustable thermostat. These units were factory set and no additional adjustment is possible. Early production water heaters are equipped with an adjustable thermo-

stat (See figure 4). To adjust thermostat perform the following:

Remove the metal cover after making sure the water heater switch is turned off. Adjust thermostat to desired setting (See figure 4).

The water heater is equipped with a reset button. In the event the tank gets overheated a thermal sensing switch will automatically disconnect the heater. To reset the unit remove the metal cover and push the red reset button.

## WATER TANK

### REMOVAL

1. Remove cushions and wood cover over water tank.
2. Open tank drain valve as shown in Figure 5 and allow tank to drain.
3. Disconnect tank vent hose.
4. Disconnect water fill inlet tube or elbow at tank.
5. Disconnect tank sending unit wires if equipped and tank hold down strap brackets.

**NOTE:** Straps do not have to be cut.

6. Disconnect the suction hose at the pump and the drain hose from the tee or valve depending on which is more accessible.

7. Remove tank.

### WATER TANK REPAIR

The tank is manufactured from polypropylene plastic. Except for small, clean punctures the tank is not repairable. Polypropylene resists all common adhesives that may be used in patching or plugging. However, on small punctures a Well-Nut may be used. Enlarge the hole enough to insert the Well-Nut and tighten enough to close up the hole to make it waterproof.

### INSTALLATION

1. Install tank.
2. Connect drain hose to valve or tee. Connect suction hose to water pump. Tighten clamps securely.
3. Position hold-down straps and secure strap brackets to the floor.
4. Connect tank sending unit wires, if equipped.
5. Connect water tank fill inlet tube or elbow. Tighten clamps securely.
6. Connect tank vent hose and tighten clamp securely.
7. Close drain valve.

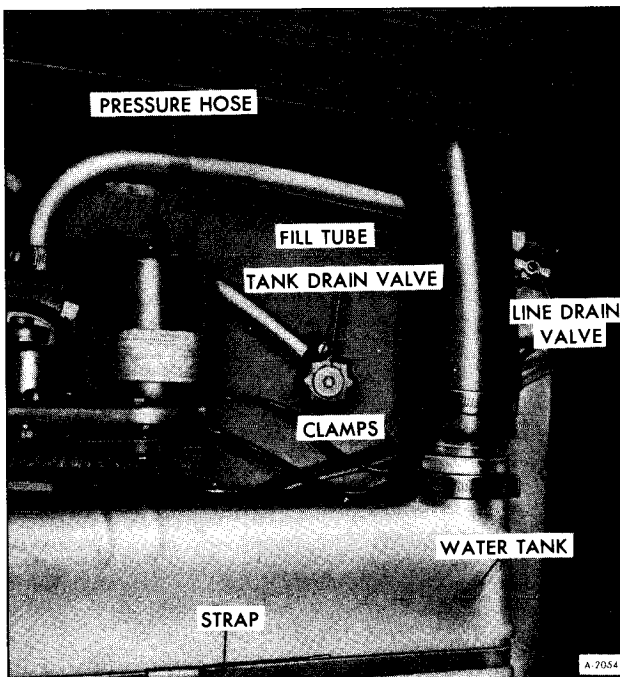

Figure 5—Water Tank Drain Valve Location

8. Fill water tank and turn on pump to pressurize the system. Check for leaks.

9. Replace wood cover over water tank and cushions.

## WATER TANK SENDING UNIT (IF EQUIPPED)

### REMOVAL

1. Disconnect battery ground cables and then remove cushions and wood cover over water tank.

2. Drain tank enough so water is below sending unit opening.

3. Disconnect water tank inlet elbow or tube at the tank and position out of the way.

4. Disconnect sending unit wires and remove sending unit nuts.

5. Remove sending unit.

### INSTALLATION

1. Install sending unit, tighten nuts securely.

2. Connect sending unit wires.

3. Connect tank fill tube or elbow at tank and tighten clamp securely.

4. Fill tank and check for leaks.

5. Install wood cover and cushions.

6. Connect battery ground cables and then at monitor panel check for proper operation of sending unit.

## WATER PUMP

### REMOVAL

1. Remove wood cover over water tank compartment.

2. Open tank drain valve and drain tank.

3. Make sure pump wall switch is turned off and disconnect battery ground cables.

4. Disconnect hoses from water pump. See Figure 6.

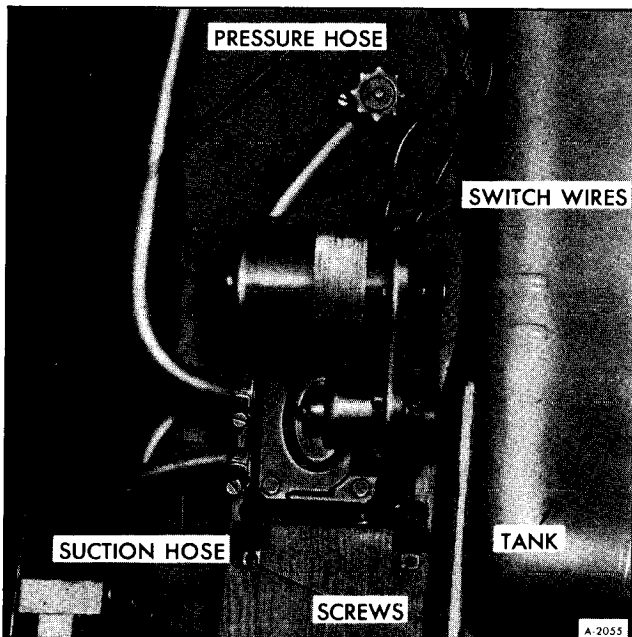

Figure 6-Water Pump

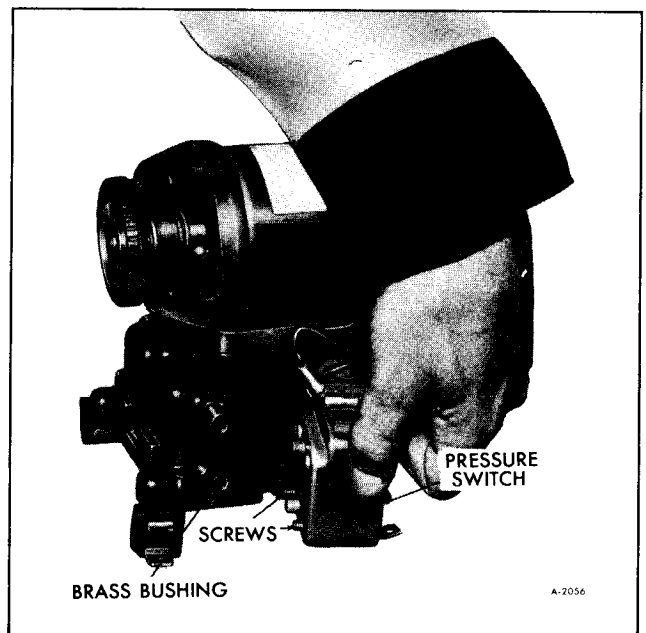
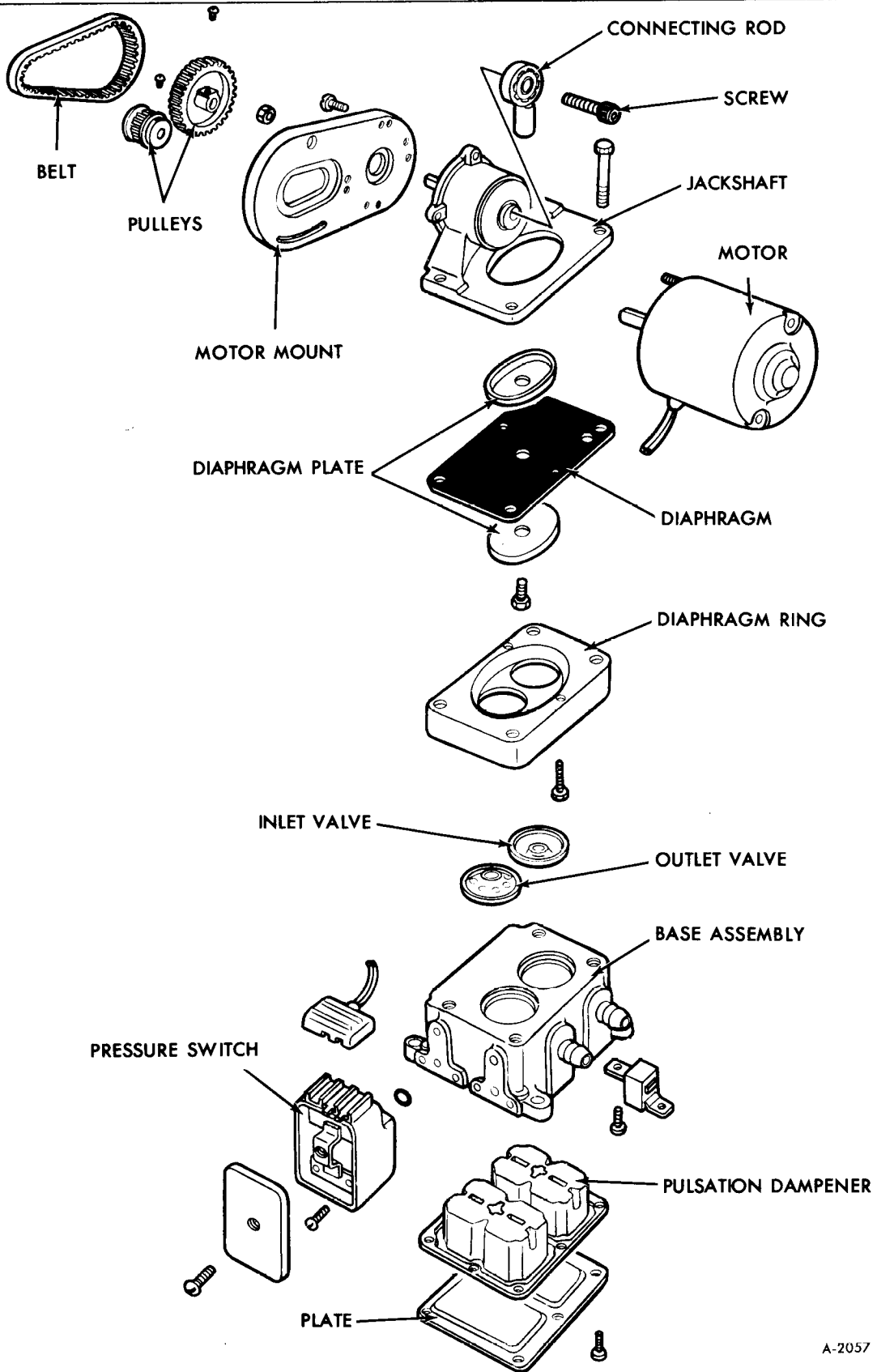

Figure 7-Removing Pressure Switch





A-2057

Figure 8-Water Pump Components

5. Disconnect tank fill elbow at the tank if equipped.

6. Remove four (4) pump hold down screws. See Figure 6.

7. Lift pump assembly out and disconnect wires from the pressure switch.

### DISASSEMBLY

1. Remove two (2) nuts as shown in Figure 2 and remove belt.

2. Remove both pulleys.

3. Remove two (2) screws securing motor mount to the jack shaft assembly.

4. Remove pressure switch cover and loosen two (2) screws securing the switch to the base assembly. See Figure 7.

5. Remove switch from base assembly and disconnect wires from the switch.

6. Remove motor assembly.

7. Remove connecting rod screw and slip connecting rod off jack shaft (See figure 8).

8. Remove four (4) screws securing the jack shaft assembly to the base assembly and lift the jack shaft and diaphragm ring off the base assembly. Inspect diaphragm for cracks, replace if necessary.

9. Lift valve assemblies from pockets and clean all foreign material from valve and valve seat.

10. Remove nine (9) screws securing bottom plate to base assembly (See figure 8).

11. Remove plate and pulsation dampener. Check dampener for a rupture. Replace if ruptured.

### ASSEMBLY

1. Install pulsation dampener being careful that all dampener flanges will properly seat with plate.

2. Install bottom plate and nine (9) screws.

**CAUTION:** *To avoid casting damage and obtain proper compression on dampener flange, tighten screws evenly until flange edge of bottom plate is flush with bottom of case casting.*

3. Install valve assemblies back in same pockets, being sure rubber valve with small hole is up on intake side of base assembly and rubber without small hole is down on discharge side of base assembly (See figure 8).

4. Install diaphragm ring, diaphragm and jack shaft assembly. Install four (4) screws and tighten securely.

5. Install connecting rod screw.

6. Install motor mount to jack shaft assembly and secure with two (2) screws.

7. Install motor and loosely secure with two (2) nuts.

8. Install wires from motor to pressure switch and install pressure switch. Be sure to include brass bushing as shown in Figure 7. Secure pressure switch with two (2) screws.

9. Install pressure switch cover.

10. Install both pulleys and secure with set screws.

11. Install belt and tension properly. Refer to "On-Vehicle Adjustment-Water Pump Belt" earlier in this section.

### INSTALLATION

1. Connect wires to pressure switch and install pump assembly.

2. Install four (4) pump hold down screws.

3. Connect water tank fill elbow at the tank, if removed, and secure with clamp.

4. Connect hoses to water pump and secure with clamps.

5. Close tank drain valve and fill water tank.

6. Connect battery ground cables and turn on wall switch and open faucet. Close faucet and allow system to pressurize. Check for leaks at the water pump and hose connections.

7. Install wood cover and cushions.

### BELT REPLACEMENT

#### REMOVAL

1. Turn off pump at wall switch.

2. Loosen two (2) nuts as shown in Figure 2.
3. Slide motor toward jack shaft assembly to release tension.
4. Remove belt.

## INSTALLATION

1. Position belt over pulleys.
2. Tension belt as described in "On-Vehicle Adjustment-Water Pump Belt".
3. Tighten nuts.
4. Turn on pump at wall switch and check for proper operation.

## PRESSURE SWITCH

### REMOVAL

1. Disconnect battery ground cables and turn off pump at the wall switch.

2. Remove four (4) screws securing pump assembly (See figure 6).
3. Lift pump assembly and position so access may be gained to the pressure switch.
4. Remove switch cover and two (2) screws attaching switch to pump.
5. Remove switch and disconnect wires.
6. Inspect switch contact points for corrosion. Clean with sand paper or small file if necessary.

### INSTALLATION

1. Connect wires to switch and secure switch to pump.
2. Install switch cover.
3. Place pump assembly in original position and secure with four (4) screws and connect battery ground cables.
4. Turn on pump at wall switch.

## WATER HEATER

### REMOVAL

1. Disconnect battery ground cables, and turn off water heater switch and turn off water pump switch.
2. Open drain valve and allow water heater to drain (See figure 4).
3. Remove sliding doors, door frame and shelf liner in the bath vanity.
4. Disconnect heater pre-heat hoses if equipped and plug the hoses.
5. Remove pressure-temperature relief valve tube.
6. Remove drain line.
7. Disconnect wires and armored cable from junction box on wall.
8. Remove inlet (cold) water line.
9. Disconnect outlet (hot) water line and reposition out of the way.

10. Remove banding straps.
11. While supporting heater, disconnect heater support bracket and position the water heater upward and outward.
12. Toilet seat may have to be raised or removed in order to remove heater.
13. Remove heater.

### DISASSEMBLY

1. Remove the pressure-temperature relief valve (See figure 4). Remove drain valve.
2. Remove metal cover and remove red plastic cover over electrical control assembly (See figure 4).
3. Disconnect wire and remove control assembly as shown in Figure 9.
4. Remove heater element as shown in Figure 10 by removing four (4) bolts.

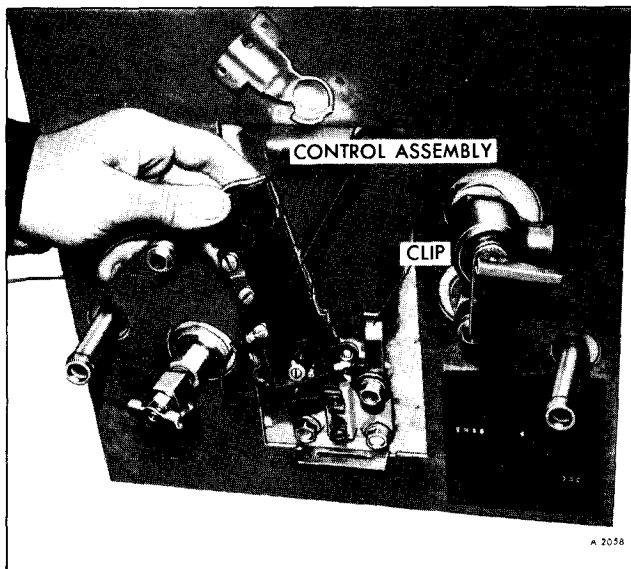

Figure 9—Removing Control Assembly

5. Remove four (4) screws attaching front of box to body.
6. Remove front of box.
7. Slide out inner tank assembly.

## ASSEMBLY

1. Slide inner tank assembly into box.
2. Install front of box and secure with four (4) screws.



Figure 10—Removing Heater Element

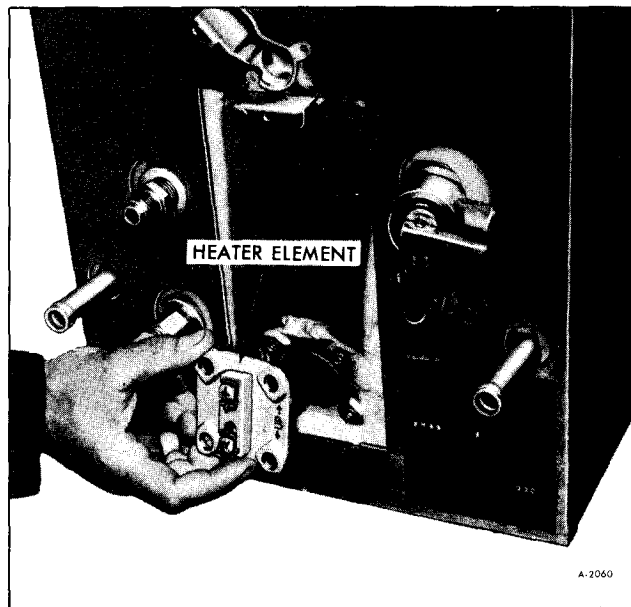

Figure 11—Installing Heater Element

3. Install heater element in the direction specified by the word UP, as shown in Figure 11.
4. Evenly tighten four (4) bolts until element contacts tank.
5. Install electrical control assembly and connect wires.
6. Install red plastic cover and metal cover. Secure metal cover with screw.
7. Install pressure-temperature relief valve and drain valve. Use a thread sealer on all threads.

## INSTALLATION

1. Cut two pieces of banding strap five (5) long and string through brackets on wall.
2. Position support bracket outward and slide heater into position.
3. Secure support bracket with screws.
4. Use banding tension tool and clips to secure straps tightly around heater.
5. Connect inlet (cold) and outlet (hot) pipes. Use thread sealer.
6. Connect wires and armored cable to junction box on wall.
7. Install drain line. Use thread sealer.

8. Install pressure-temperature relief valve tube. Use thread sealer.

9. Connect heater pre-heat hoses if equipped and secure with clamps.

10. Install shelf liner, door frame and sliding doors.

11. Close water heater drain valve. Connect battery ground cables.

12. Turn on water pump allow heater tank to fill. Open a hot water faucet to check if tank is filled.

13. Check for leaks.

14. Turn on heater switch and check for hot water after approximately 15 minutes. Be sure vehicle is connected to 120-volt AC source by running Motor Generator or external power connection.

## BATHROOM SINK FAUCET

### REMOVAL

1. Turn off water pump at wall switch. Open faucet to reduce line pressure.

2. Disconnect water lines.

3. Remove lock nuts as shown in Figure 12. Remove steel and fiber washers.

4. Disconnect shower line.

5. Remove faucet assembly.

### INSTALLATION

1. Install faucet assembly.

2. Connect shower line.

3. Install fiber and steel washers.

4. Install lock nuts and tighten securely.

5. Connect water lines.

6. Turn on water pump switch and operate faucet. Check for leaks.

### FAUCET WASHERS (FIGURE 12)

#### REMOVAL

1. Remove screw and faucet handle.

2. Remove faucet gland nut.

3. Remove faucet stem.

4. Remove screw securing washer, remove washer.

5. Inspect washer seat for excessive roughness.

Replace if necessary.

### INSTALLATION

1. Install washer on stem and secure with screw.

2. Install faucet stem into faucet.

3. Install gland nut.

4. Install faucet handle and secure with screw. Check for leaks.

## SHOWER DIVERTER ASSEMBLY (FIGURE 12)

### REMOVAL

1. Turn off water pump at wall switch. Open faucet to reduce line pressure.

2. Remove diverter screw.

3. Pull out diverter assembly.

4. Inspect "O" rings and replace if necessary.

### INSTALLATION

1. Install stem, bushing and knob and secure with diverter screw.

2. Turn on water pump at wall switch. Check for leaks.

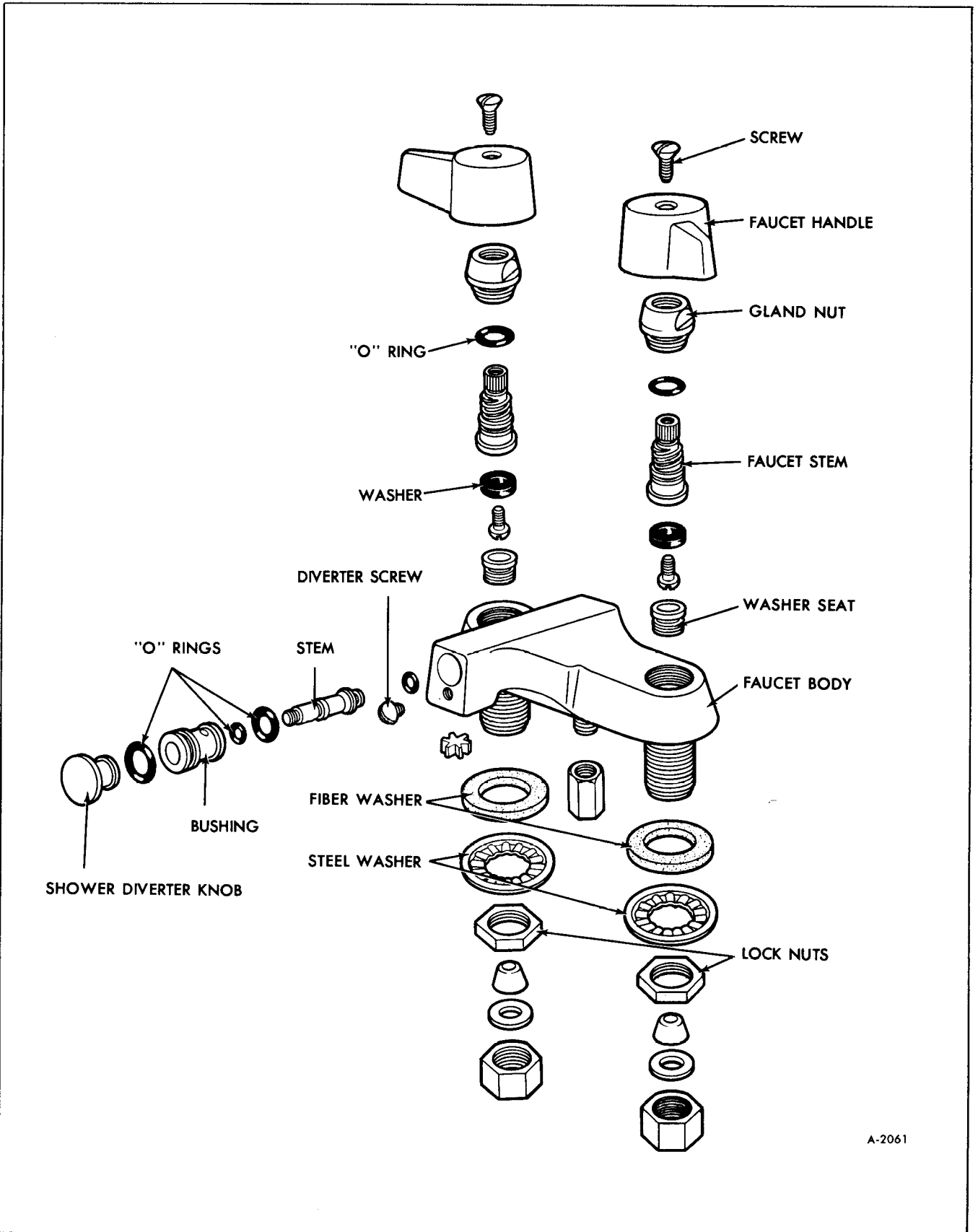

A-2061

Figure 12-Bathroom Sink Faucet Assembly

## SHOWER HEAD AND HOSE

### REMOVAL

1. Turn off water pump at wall switch. Open faucet to reduce line pressure.
2. Remove shower head hose from wall connection (See figure 13).
3. Remove hose from shower head connector.
4. Remove shower head from connector.

### INSTALLATION

1. Install shower head to connector.
2. Install hose to shower head connector.
3. Connect hose to wall connection.
4. Turn on water pump at wall switch. Operate shower as it is directed into sink and check for leaks.

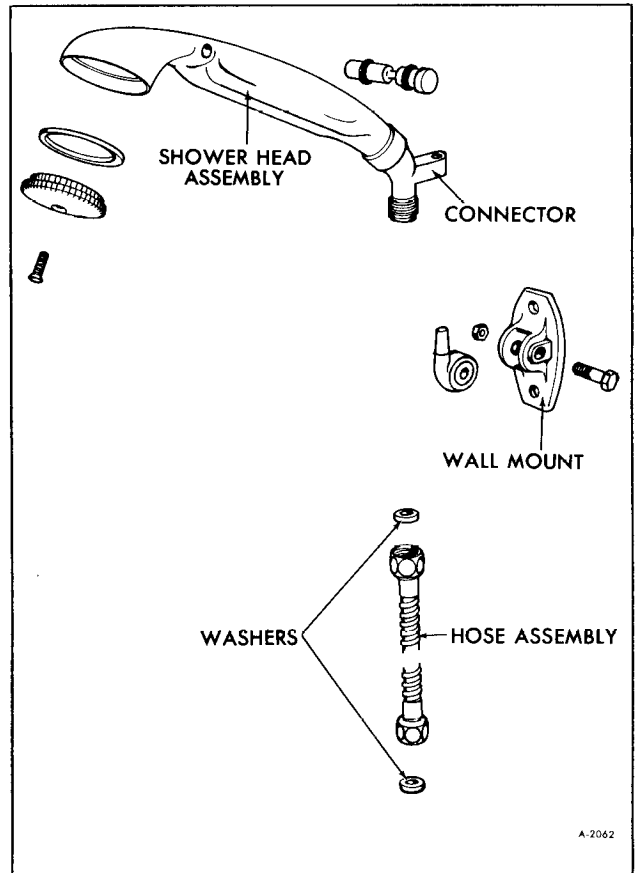

Figure 13-Shower Head Components

## GALLEY SINK

### REMOVAL (FIGURE 14)

1. Turn off water pump at wall switch. Open faucet to reduce line pressure.
2. Disconnect water lines from faucet. Include, disconnect water purifier spout, if equipped.
3. Remove sink retaining clips (See figure 15).
4. Disconnect drain lines.
5. Lift sink out.

### INSTALLATION (FIGURE 14)

1. Position sink into place and secure with clips (figure 15).

2. Connect all water lines and drain lines.

3. Turn on water pump at wall switch. Operate faucet and water purifier (if equipped) and check for leaks.

### GALLEY SINK FAUCET

#### REMOVAL

1. Turn off water pump at wall switch. Open faucet to reduce line pressure.
2. Disconnect water lines from faucet.
3. Remove lock nuts steel and fiber washers (See figure 14).
4. Remove faucet.

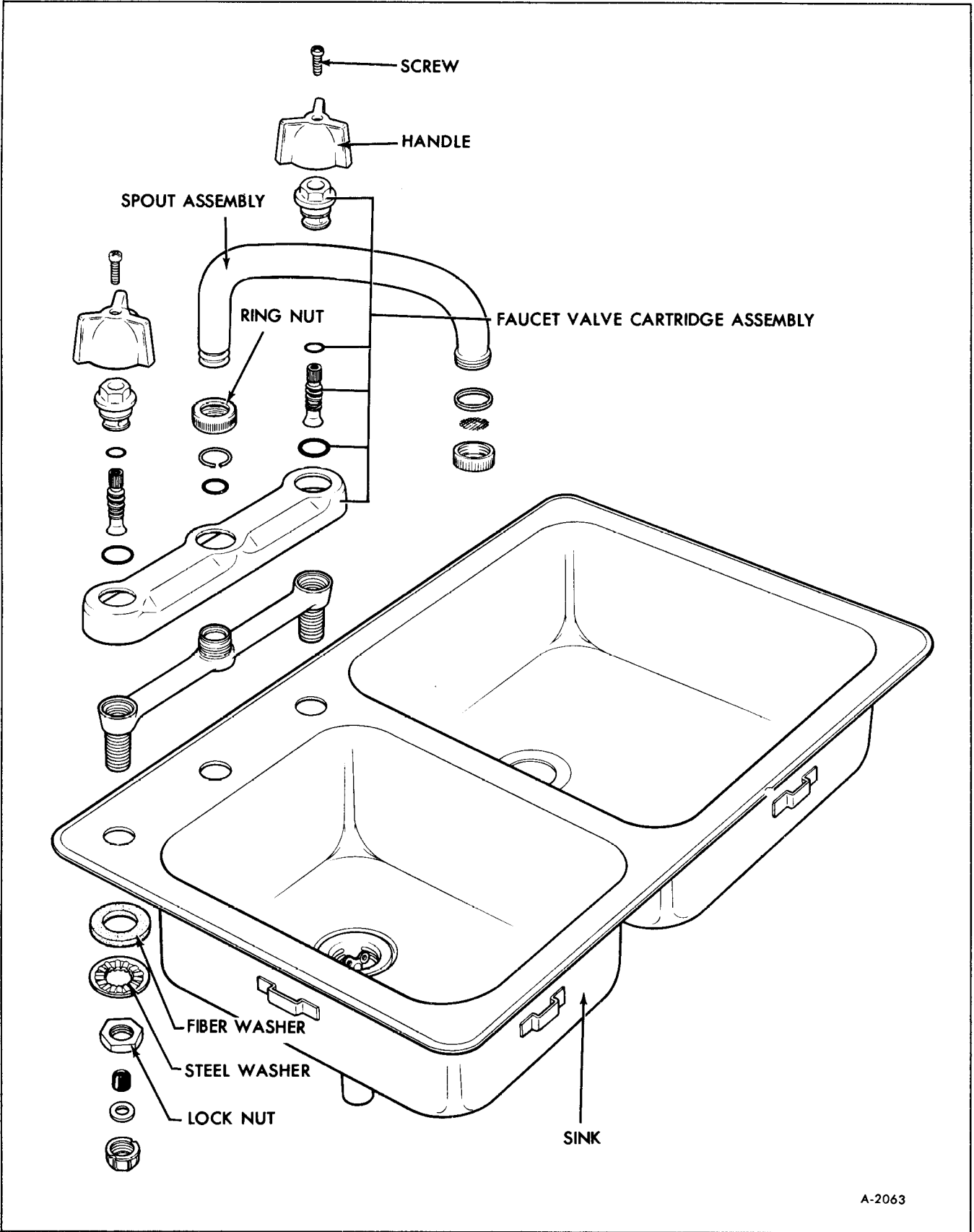

Figure 14-Galley Sink Components



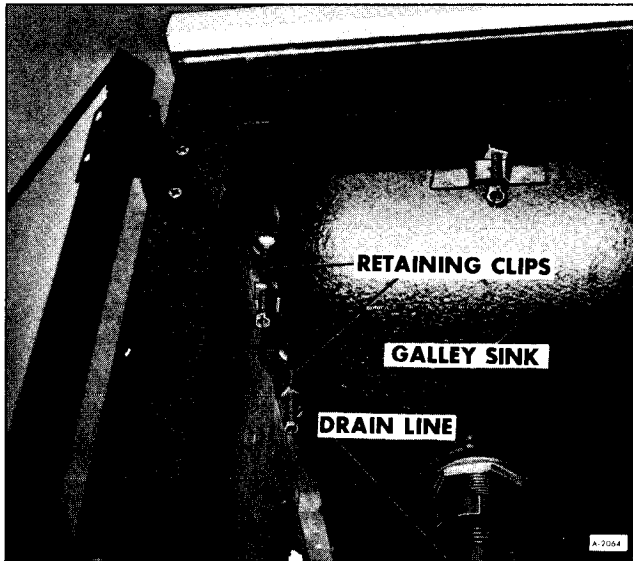

Figure 15—Sink Retaining Clips

## INSTALLATION

1. Install faucet, fiber and steel washers. Secure with lock nuts.
2. Connect water lines.
3. Turn on water pump and operate faucet. Check for leaks.

## FAUCET VALVE CARTRIDGE ASSEMBLY

### REMOVAL (FIGURE 14)

1. Turn off water pump wall switch. Open faucet to reduce line pressure.

## WATER PURIFIER (OPTIONAL)

### FAUCET REMOVAL

1. Turn off water pump and open faucet to reduce line pressure.
2. Disconnect water line.
3. Remove lock nut, steel and fiber washers (See figure 16).
4. Remove faucet assembly.

### FAUCET INSTALLATION

1. Install faucet assembly, fiber and steel washer. Secure with lock nut.

2. Remove handle retaining screw and handle.
3. Remove faucet valve cartridge assembly.

### INSTALLATION (FIGURE 14)

1. Install faucet valve cartridge assembly.
2. Install handle and secure with screw.
3. Turn on water pump, operate faucet and check for leaks.

## FAUCET SPOUT

### REMOVAL (FIGURE 14)

1. Turn off water pump and open valve to reduce line pressure.
2. Remove spout to faucet ring nut.
3. Remove spout.

### INSTALLATION (FIGURE 14)

1. Install spout and secure with ring nut.
2. Turn on water pump, operate faucet and check spout for leaks.

2. Connect water line.

3. Turn on water pump and operate purifier. Check for leaks.

## PURIFIER VALVE STEM

### REMOVAL (FIGURE 16)

1. Turn off water at in line valve and depress purifier button to reduce line pressure.
2. Remove push button and stem assembly.

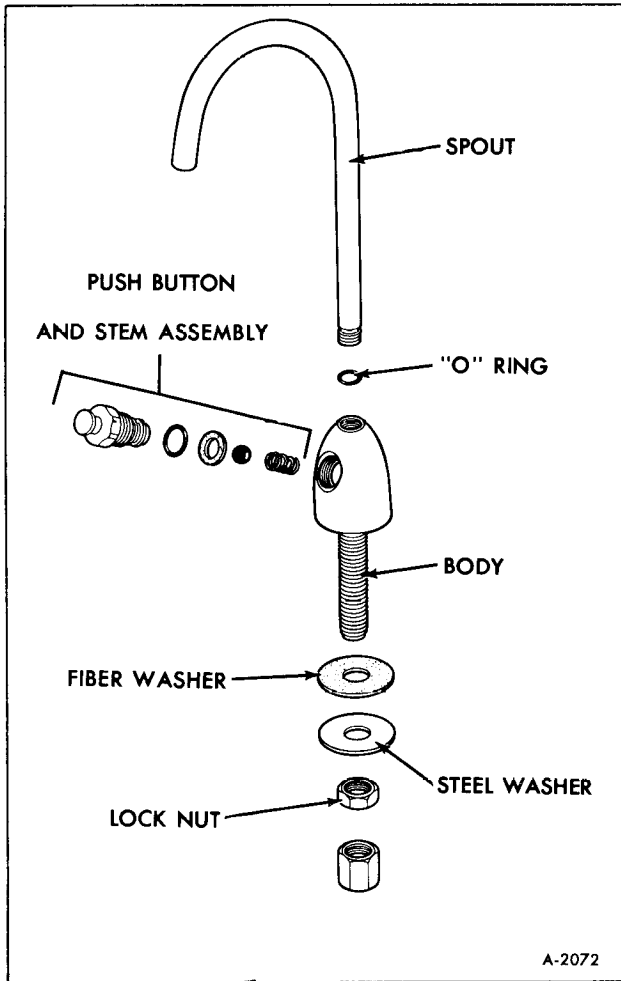

Figure 16–Water Purifier Faucet

3. Inspect washer, “O” ring and check ball for roughness.

### INSTALLATION (FIGURE 16)

1. Install push button and stem assembly. Tighten lock nut securely.

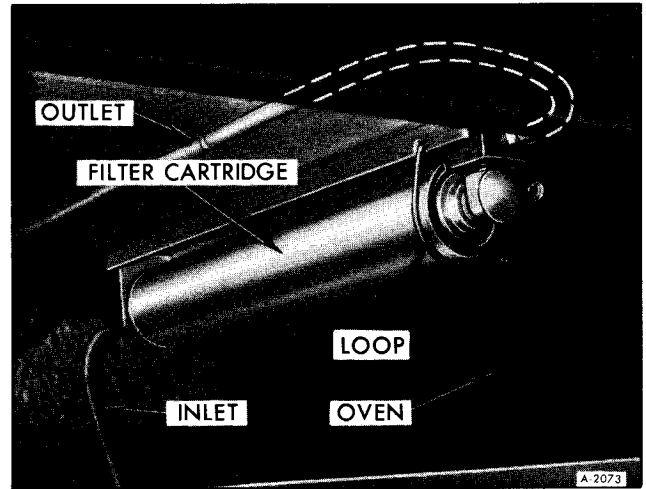

Figure 17–Water Purifier Cartridge

2. Turn on water at valve and operate purifier. Check for leaks.

### WATER PURIFIER CARTRIDGE REMOVAL

1. Turn off water at in line valve. Depress purifier button to reduce line pressure.

2. Slide cartridge retaining bail (See figure 17).

3. Pull cartridge down approximately one (1) inch then outward to remove.

### INSTALLATION

1. Insert cartridge into bracket and swing bail over the end (figure 17).

2. Turn on water at valve, operate purifier and check for leaks.

## CITY WATER CONNECTION

### REMOVAL

1. Turn off water pump, open faucet to reduce line pressure.

2. Remove four (4) retainer screws on outer ring and six (6) screws on inner ring.

3. Remove retainer ring and valve assembly.

4. Remove wooden, access cover from inside of clothes closet.

5. Remove valve base plate.

## INSTALLATION

1. Install valve base plate.
2. Install valve assembly and retainer ring.
3. Secure inner and outer rings with screws.
4. Turn on water pump and lightly depress gray button in valve until water appears. Release button and check for leaks.
5. Install wooden access cover in clothes closet.

## WATER LINES AND CONNECTIONS

All waterlines are made of copper except the following: The water pump inlet and outlet is serviced by short pieces of rubber hose.

Copper fittings include compression, sweat solder and flared connections. Repair of these fittings is by standard plumbing methods.



# SECTION 24K TOILET

## STANDARD TOILET (AQUA-MAGIC)

### GENERAL INFORMATION

The standard toilet (figure 1) is a fresh water, permanently installed sanitation system. It uses a pressure flushing system. This scours the bowl with

each flush. Water injection produces a "swirl effect" and uses a measured amount of water to rinse efficiently. The unit is a self cleaning type with an odor tight, gas tight, teflon seal which closes off the holding tank when not in use. Since every flush uses fresh water, no mandatory chemical additives are needed.

### STANDARD TOILET TROUBLE DIAGNOSIS

Complaint	Possible Cause	Correction
Water keeps running into the bowl.	The blade in the bottom of the bowl is not closing completely, which in turn keeps the water control valve partially open. The groove into which the blade seats when completely closed is clogged with foreign material.	Insert the end of a coat hanger or similar object into the sealing groove and remove the foreign material. Avoid damaging the rubber seal while cleaning.
Toilet leaks. There is water on the floor.	Specify the symptom. Determine if water is leaking from: a. The vacuum breaker.  b. The water control valve.  c. Bowl to mechanism seal (if this is the problem, the water would not stay in the bowl).	a. The vacuum breaker—if the vacuum breaker leaks when flushing the toilet, replace the vacuum breaker. b. If the vacuum breaker leaks when the toilet is not in operation, replace the water control valve. c. Leaks at the bowl to mechanism seal— remove mechanism, and replace mechanism seal.

Complaint	Possible Cause	Correction
Contd. from previous page.	d. Closet flange base seal.	d. Leaks at closet flange area—check front and rear closet flange nuts for tightness. If leak continues remove the toilet, check the closet flange height. The height should be between 1/4" and 7/16" above the floor. Adjust closet flange height accordingly and replace closet flange seal.
Foot pedal operates harder than normal or the blade sticks.	This is generally caused by using cleansers or other abrasives to clean the bowl. The foreign material scrapes away the teflon on the blade seal and the amount of friction is increased to the point where dragging occurs. It can also be caused by using water, which contains a high content of suspended foreign material such as sand.	Wipe the blade completely dry, spray with a silicone spray and work the pedal several times. Repeat until blade works freely.

## TOILET REMOVAL

1. Turn off water pump and release pressure at any faucet.
2. Disconnect toilet water line.
3. Depress flush pedal and insert block of wood or similar object in slide trap to keep trap open. This holds the flush pedal down for access to front mounting nut.
4. Remove front mounting nut.
5. Depress pedal and remove block.
6. Lift toilet seat lid and remove access cap for the rear mounting nut.
7. Remove rear mounting nut using at least a 12" extension and a universal socket through the access hole.
8. Lift off toilet.

## DISASSEMBLY AND REPAIR

The toilet disassembles into four main subassemblies (See figure 1).

1. The seat and cover assembly.
2. The vacuum breaker.
3. The mechanism assembly.
4. The hopper assembly.

Any of these subassemblies may be removed from the toilet in the following manner:

1. Removal of the seat and cover assembly (figure 1):

With seat and cover assembly in the up position use a flat screwdriver or similar tool to pull out the seat hinge pins.

2. Removal of the vacuum breaker (figure 1):

Remove seat and cover assembly as explained in last paragraph. Then turn the toilet up-side-down. To remove water lines from vacuum breaker base, pinch hose clamps with a pair of pliers and slide them up the water line. Water lines may be pulled off. Remove the two vacuum breaker attachment screws.

3. Removal of the mechanism assembly (figure 1):

Turn the toilet up-side-down. Remove the six screws that are now visible. Lift up mechanism to gain access to water line hose clamps. Pinch hose clamps with a pair of pliers and slide them up the water line. Pull water lines off of mechanism.

4. Service and replacement of hopper assembly:

Hopper assembly may be serviced or replaced by removing the above 3 assemblies.

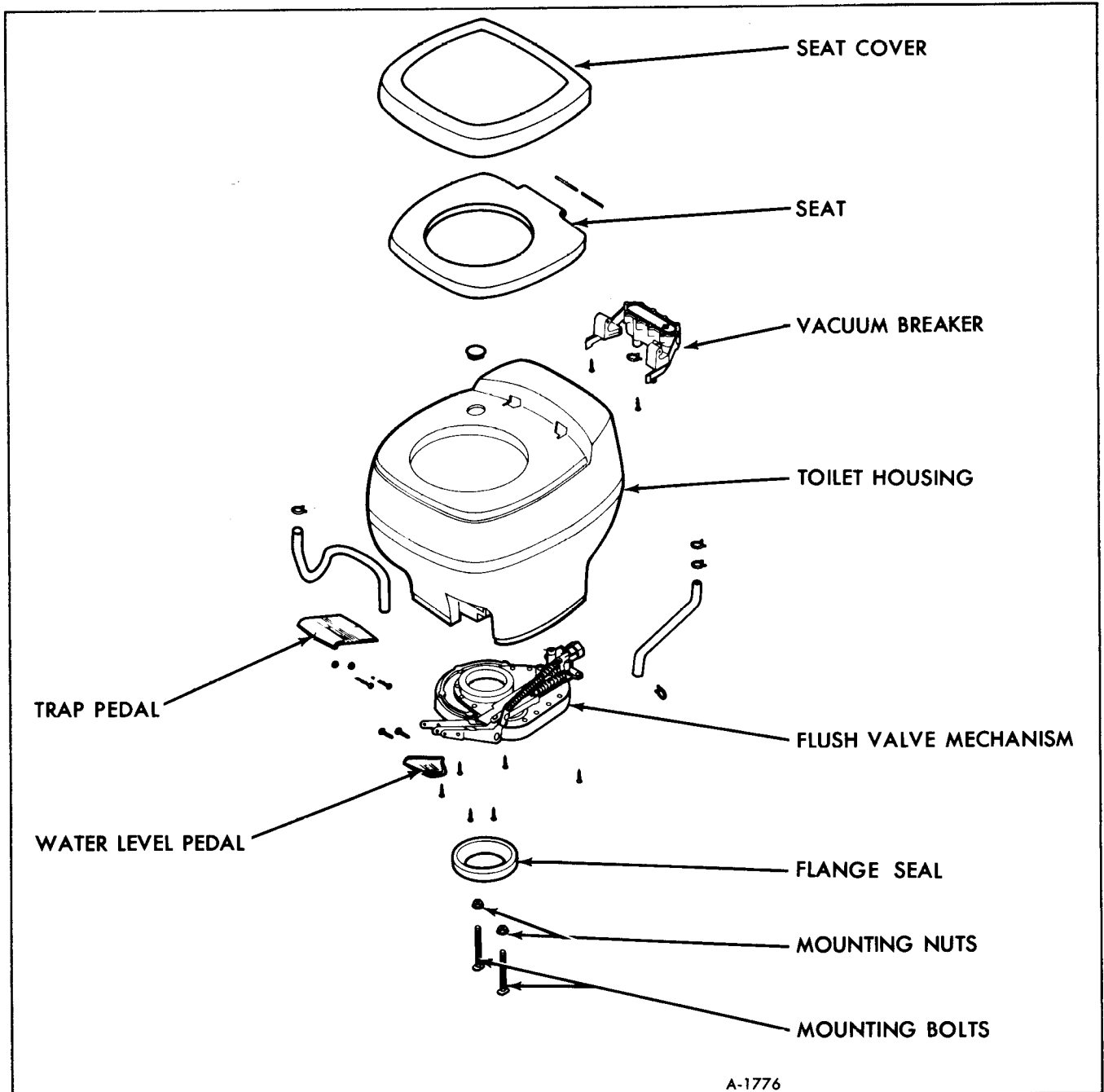

Figure 1-Standard Toilet Components

## TOILET INSTALLATION

1. Install a new flange seal over mechanism ring found on underside of toilet.
2. Set toilet in place and install rear mounting nut using the 12" extension and universal socket with a small amount of grease in the socket to hold the nut in place.
3. Tighten rear mounting nut.
4. Depress toilet pedal and insert block of wood in slide trap to keep the trap open. This holds the pedal down for access to front mounting bolt. Install nut and tighten.
5. Depress pedal and remove block of wood.

6. Connect toilet water line.

## MAINTENANCE

No routine maintenance is required.

If the bowl sealing blade does not operate freely after extended use, it may be restored to its original, smooth operating condition by applying a light film of Silicone spray to the blade.

To clean the toilet, use any high grade, non-abrasive cleaner. Do not use highly concentrated or high acid content household cleaners. They may damage the rubber seals.

## RECIRCULATING TOILET (ELECTRA-MAGIC)

### GENERAL INFORMATION

The optional recirculating toilet operates by recirculating the liquid present in the toilet and a

chemical additive. The advantage is that water is conserved when flushing and also not adding to the volume of the holding tank. The toilet operates on 12-volt DC.

## RECIRCULATING TOILET TROUBLE DIAGNOSIS

Complaint	Possible Cause	Correction
1. Toilet will not flush.	<ol style="list-style-type: none"> <li>a. Blown living area fuse.</li> <li>b. Blown toilet fuse.</li> <li>c. Pump motor defective.</li> <li>d. Damaged timer.</li> </ol>	<ol style="list-style-type: none"> <li>a. Replace blown fuse in living area electrical compartment.</li> <li>b. Replace toilet fuse under toilet motor cover.</li> <li>c. Replace pump assembly.</li> <li>d. Replace timer assembly.</li> </ol>
2. Toilet does not cycle properly (5 to 9 seconds) when button is pressed.	<ol style="list-style-type: none"> <li>a. Source of power less than 12-volts.</li> <li>b. Damaged timer.</li> </ol>	<ol style="list-style-type: none"> <li>a. Check batteries or power converter.</li> <li>b. Replace timer assembly.</li> </ol>
3. Toilet cycles when seat cover is raised.	<ol style="list-style-type: none"> <li>a. Actuator button protrudes too far from motor cover.</li> </ol>	<ol style="list-style-type: none"> <li>a. Alternately press one side of the button, then the other, to work the button back further into the housing. If button still protrudes too far, replace timer assembly.</li> </ol>
4. Flushing action is weak or noisy.	<ol style="list-style-type: none"> <li>a. Unit cycling without adequate water charge.</li> <li>b. Source of power less than 12-volts.</li> <li>c. Pump damaged by continuous dry operation.</li> </ol>	<ol style="list-style-type: none"> <li>a. Charge unit with water to the proper level.</li> <li>b. Check batteries or power converter.</li> <li>c. Replace pump assembly.</li> </ol>

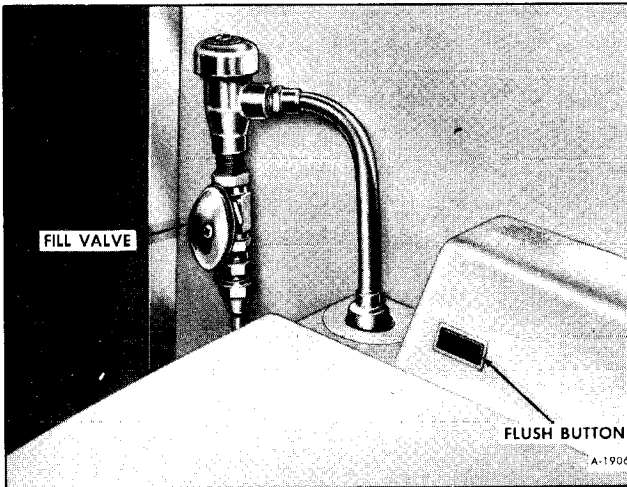

Figure 2—Toilet Water Fill Connection

## TOILET REPLACEMENT

### REMOVAL

1. Turn off water pump and release pressure at any faucet.
2. Disconnect toilet water fill line shown in Figure 2, and disconnect the toilet wires.
3. Remove base moldings from lower sides of toilet.
4. Remove the two nuts under the toilet securing it to the floor.
5. Lift off toilet.

### INSTALLATION

1. Install new flange seal on slide valves.
2. Place toilet on flange making sure bolts line up through mounting brackets.
3. Secure toilet in place with two nuts under toilet at mounting brackets.
4. Connect toilet water fill line and wires (figure 2).

## DISASSEMBLY AND REPAIR (FIGURE 3)

### FUSE REPLACEMENT

1. Remove two cover mounting screws and motor cover.

2. The fuse is now accessible for checking or changing, see Figure 3.

### TIMER REPLACEMENT

1. Disconnect lead wires from power source (figure 3).
2. Remove two cover mounting screws and motor cover (figure 1).
3. Disconnect leads from pump assembly motor (figure 3).
4. Remove two timer bracket mounting screws and timer assembly.
5. Install by reversing steps 1–4.

### PUMP REPLACEMENT

1. Disconnect lead wires from power source.
2. Remove two cover mounting screws and motor cover.
3. Disconnect leads from pump assembly motor.
4. Completely evacuate unit.
5. Remove cover and bowl assembly screws (two in rear from top side and two in front from bottom side) and remove cover and bowl assembly (figure 3).
6. Remove four pump mounting screws (figure 3).
7. Disconnect flush tube from pump outlet (figure 3).
8. Remove pump assembly (figure 3).
9. Install by reversing steps 1–8.

### SLIDE VALVE REPLACEMENT (FIGURE 3)

1. Remove toilet from module. See “Toilet Replacement” earlier in this section.
2. Turn toilet upside down and remove the four screws and remove valve.
3. Install by reversing steps 1 and 2.



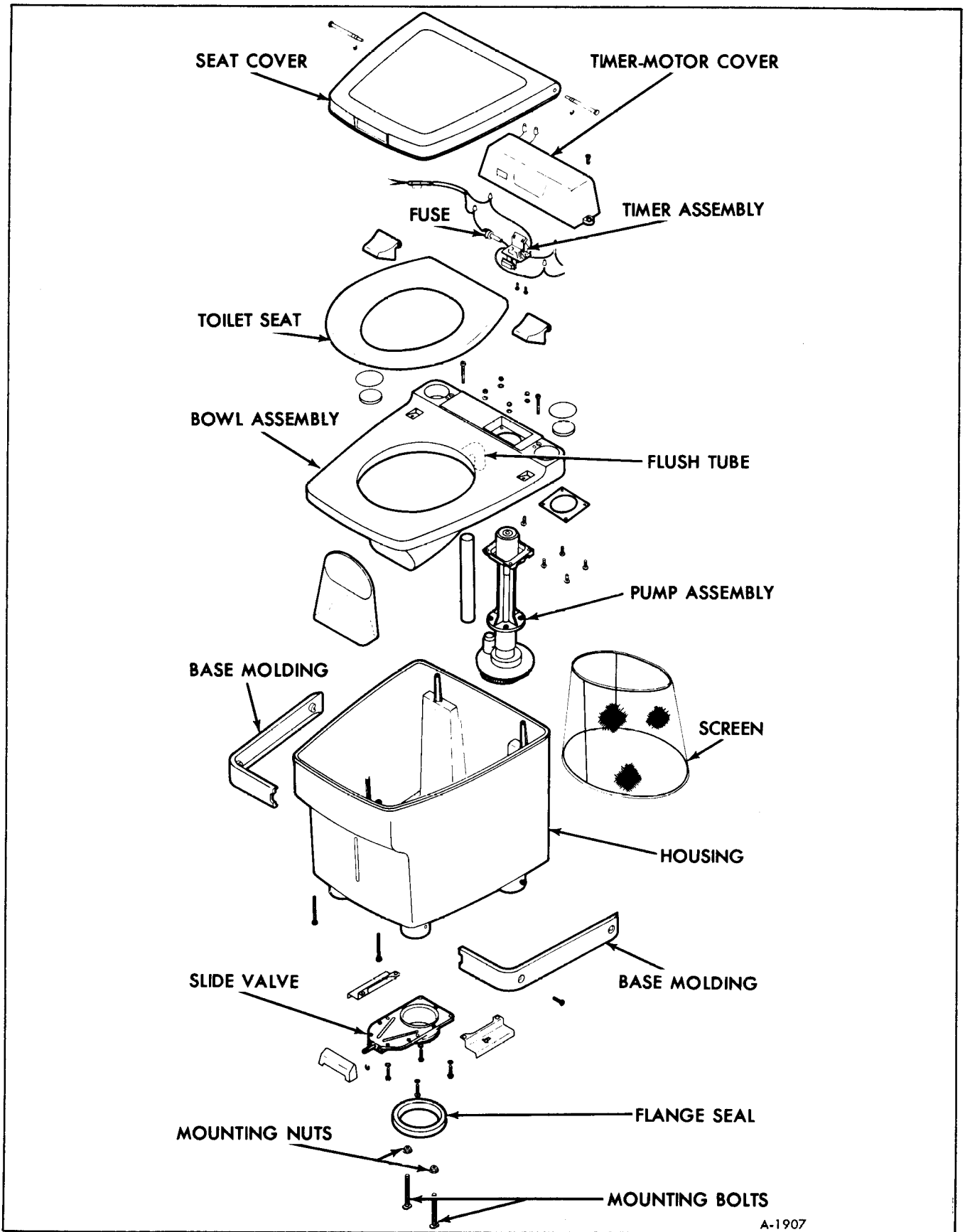

Figure 3-Recirculating Toilet Components

A-1907

## MAINTENANCE

No routine maintenance is required on the recirculating toilet other than "Charging Toilet" which is described as follows:

### CHARGING TOILET

1. Be sure handle on dump valve is pushed in.
2. Open fill valve, filling toilet to the charge level as indicated by the letter "C" on prism. This will be approximately 3 gallons. Close the fill valve.
3. Add recirculating toilet chemical as recommended by manufacturer of chemical.



# SECTION 24L HOLDING TANK AND DRAINAGE SYSTEM

The contents of this section are listed below:

SUBJECT	PAGE NO.
General Description.....	24L-1
Trouble Diagnosis .....	24L-1
Holding Tank.....	24L-3
Drain Pipe and Fittings .....	24L-6

## GENERAL DESCRIPTION

The drainage system (figure 1) consists of ABS plastic pipes and fittings. A holding tank with a capacity of approximately 32 gallons provides a place for storage of waste water from the sinks, shower and toilet.

mounted vents (2 vents on Model 230; 3 vents on Model 260).

A permanently attached hose or tube assembly to the holding tank along with a detachable sewer hose is provided for dumping the contents of the holding tank.

The tank is vented through standpipes with roof-

## TROUBLE DIAGNOSIS

Problem	Possible Cause	Correction
Monitor panel gauge in-operative.	1. Refer to "Monitor Panel-Trouble Diagnosis" in Section 24B.	1. Refer to "Monitor Panel-Trouble Diagnosis" in Section 24B.
Holding tank leaks.	1. Seal may be damaged or misaligned at the tank sending unit (if equipped), thermasan pick-up in tank (if equipped) or fullway dump valve. 2. Loose or misaligned fittings on top of tank. 3. Tank has been punctured.	1. Refer to "Holding Tank" later in this section.  2. Remove tank and correct. Refer to "Holding Tank-Removal", and "Fittings" later in this section. 3. Refer to "Holding Tank-Repair" later in this section.
Holding tank plugged up and won't empty.	1. Determine if anything was dropped into tank to cause the situation.  2. Sediment has accumulated enough to block fullway valve opening.	1. Flush tank adequately, add a tank chemical to eliminate odor during final flush. Remove fullway valve. refer to "Holding Tank" later in this section. Try fishing object out through opening. 2. Use a probe such as a broomstick handle to clear sediment away from opening. <b>NOTE:</b> Once unplugged the contents will quickly drain so be prepared and have dump hose aimed in the desired direction.

MODEL 230

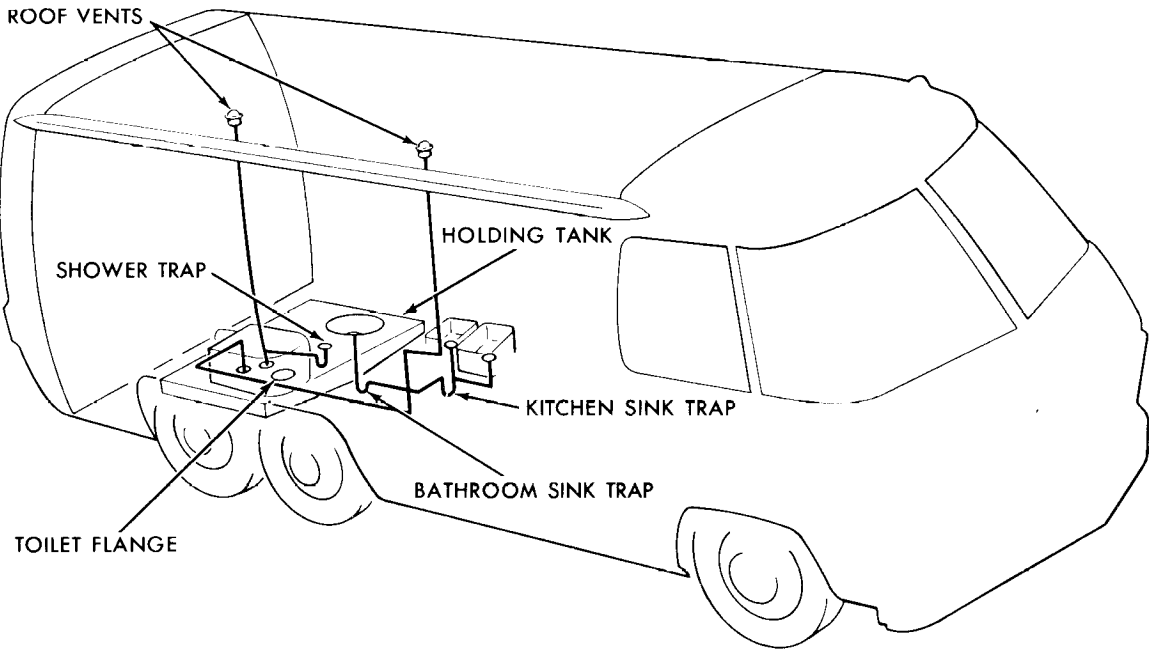

MODEL 260

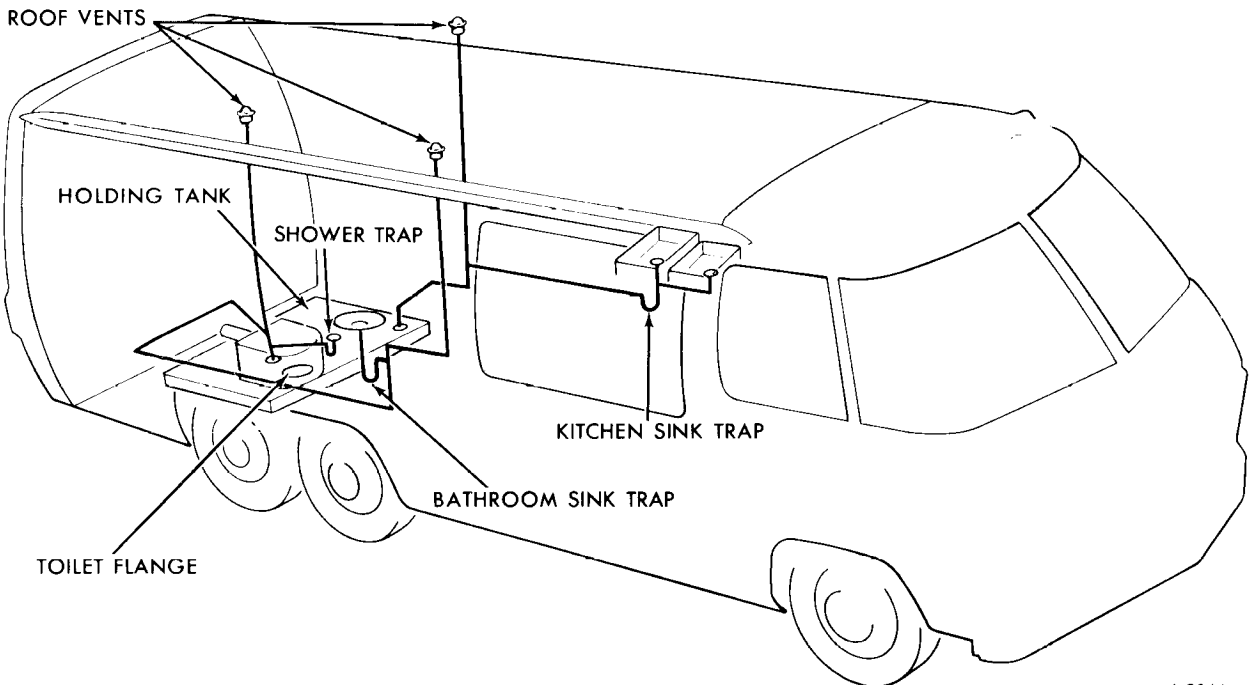

A-2044

Figure 1-Drainage System

Problem	Possible Cause	Correction
Holding tank contents backs up through shower trap and onto bathroom floor, this situation may be more common on vehicles not equipped with a monitor panel.	1. The shower trap is the lowest point of the drainage system and an over full holding tank will back up contents at this point.	1. Caution owner to dump holding tank more frequently.
Clogged drain.	1. Accumulation of grease, hair, etc.	1. Remove "P" trap and clean. Refer to "Drain Pipes and Fitting".
Drain pipe or fitting leaks.	1. Vehicle vibration may have loosened fitting or a pipe may have a hole rubbed in it by being in contact with a piece of metal. 2. Broken pipe from freezing.	1. Replace pipe or fitting. Refer to "Drain Pipes and Fittings" later in this section.  2. Replace pipe or fittings.

## HOLDING TANK

### HOLDING TANK REMOVAL

1. Drain holding tank completely and close drain valve.
2. Remove toilet assembly. Refer to the section 24K for removal procedures.
3. Remove toilet mounting flange by removing six flange to floor mounting screws. Unscrew flange from holding tank.
4. Either remove flexible discharge hose at valve by loosening hose clamp and sliding hose from valve, or remove rigid dump tube by referring to "Fullway Valve-Removal" later in this section.
5. Remove cotter pin from valve rod and remove control rod (See figure 2).
6. Remove two electrical leads from holding tank sending unit, if so equipped.
7. Remove electrical leads and hose from therma-sun pick-up unit in holding tank, if so equipped.
8. On Model 260, remove the drain pipe access cover inside the storage compartment below the Living Area Electrical Compartment then use a basin wrench as shown in Figure 3 to loosen pipe fitting from tank.
9. Remove two retaining nuts from each of the two mounting brackets (See figure 2).

10. Holding tank can now be lowered to floor.

### HOLDING TANK REPAIR

Except for small, clean punctures the holding tank is not repairable. Polypropylene plastic is used to manufacture the tank. This material resists all common adhesives that may be used in plugging or patching the tank. The very corrosive contents of the tank will quickly corrode any sheet metal, pop-rivets or screws used to plug or patch the tank.

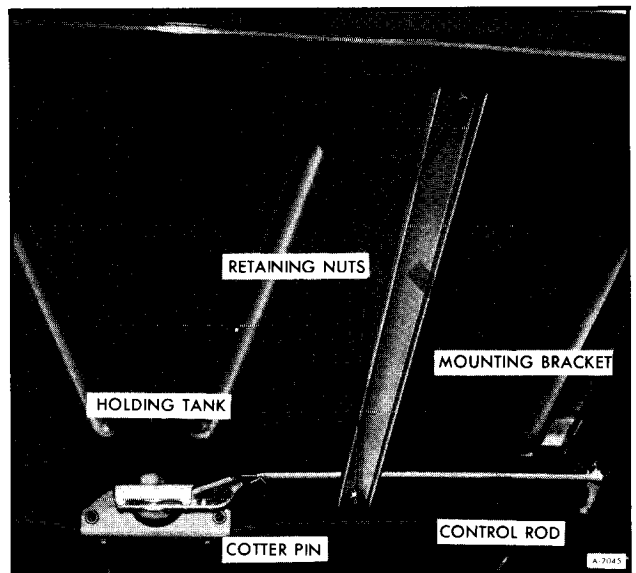

Figure 2—Holding Tank Mounting

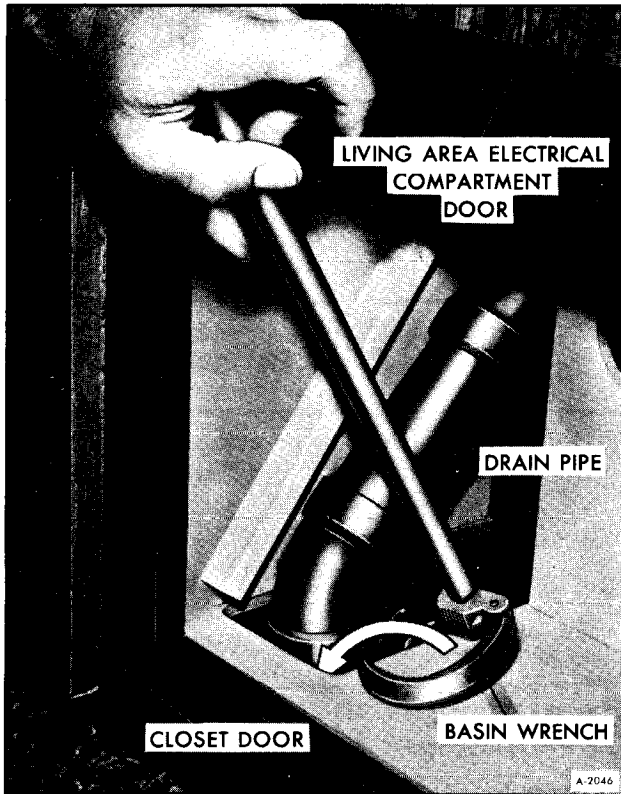

Figure 3—Loosening Pipe Fitting-Model 260

A small puncture may be repaired with the use of a well-nut. Enlarge puncture hole with a drill enough to insert well-nut. Tighten securely.

## HOLDING TANK INSTALLATION

1. Position holding tank and secure with two mounting brackets. On Model 230 torque nuts to 95-145 in.-lbs. On Model 260 install nuts and tighten with fingers. Tighten pipe connector into tank, using a basin wrench as shown in Figure 3. Install and secure drain pipe cover with three (3) screws. Torque holding tank bracket nuts to 95-145 in. lbs.

2. Connect electrical leads and hose to thermasan pick up unit in holding tank, if so equipped.

3. Connect two electrical leads to holding tank gauge sending unit, if so equipped.

4. Install valve rod on drain valve and secure with cotter pin.

5. Either connect flexible discharge hose to drain valve and secure with hose clamp or install rigid dump tube refer to "Fullway Valve-Installation" later in this section.

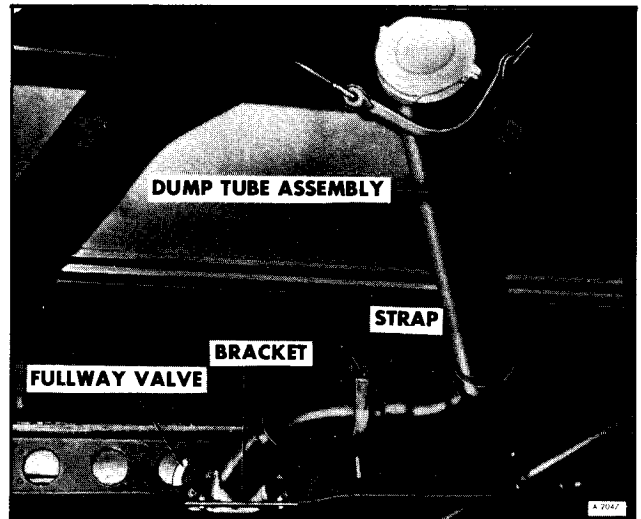

Figure 4—Dump Tube and Valve Assembly

6. Screw toilet mounting flange into holding tank and secure with six screws to floor.

7. Install toilet as described in SECTION 24K.

## FULLWAY VALVE

### REMOVAL

1. Drain holding tank completely and close fullway valve.

2. On vehicles equipped with a rigid dump tube assembly remove the four (4) screws securing valve to the tank. Remove cotter pin from control rod, then remove the bracket and strap as shown in Figure 4. Remove the fullway valve and tube assembly.

3. On vehicles equipped with a flexible hose at the holding tank, remove the hose from the valve by loosening the hose clamp and sliding the hose off the valve. Remove the cotter pin from the control rod. Remove the four (4) screws securing the valve to the tank. Remove the valve.

### INSTALLATION

1. On vehicles equipped with a rigid dump tube assembly, apply a film of grease to valve where "O" ring seats against valve. This will hold the new "O" ring in position while installing valve.

a. Position valve at holding tank and assemble enough to loosely install the strap (figure 4). Tighten fullway valve to tank screws.

b. Install bracket and torque to 15 ft. lbs. Tighten nuts securing strap.

c. Install valve rod and secure with cotter pin.

d. Check tank and valve for leaks.

2. On vehicles equipped with a flexible dump hose apply a film of grease to valve where "O" ring seats against valve. This will hold the new "O" ring in position while installing valve.

a. Position valve on holding tank and secure with four (4) screws.

b. Position discharge hose on valve and secure with hose clamp.

c. Install valve rod and secure with cotter pin.

d. Check tank and valve for leaks.

## HOLDING TANK SENDING UNIT (OPTIONAL)

### REMOVAL

1. Disconnect two electrical leads to unit as shown in Figure 5.

2. Remove five screws retaining sending unit to holding tank, and remove sending unit.

### INSTALLATION (FIGURE 5)

1. Position sending unit and new gasket at holding tank with lead wire in the three o'clock position.

2. Install five retaining screws and hook up electrical leads.

## DISCHARGE HOSE

### REMOVAL

On vehicles equipped with a flexible dump hose:

1. Remove hose at drain valve by loosening hose clamp and sliding hose off valve.

2. Loosen hose clamp at center bracket enough to allow it to slide off center support.

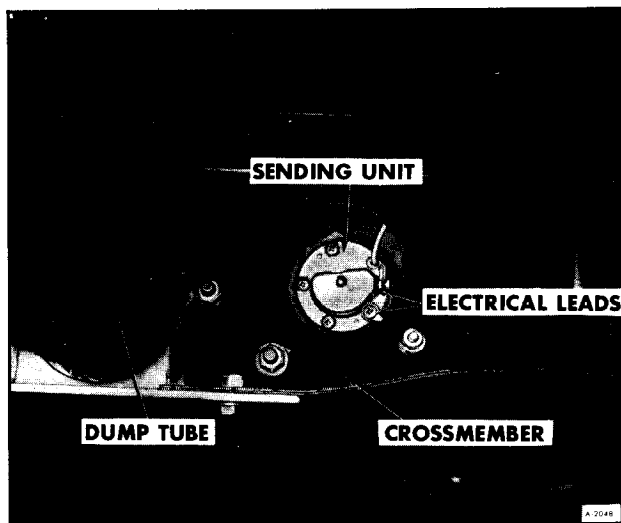

Figure 5—Holding Tank Sending Unit

3. Remove hose.

**NOTE:** On vehicles equipped with a rigid dump tube assembly refer to "Fullway Valve-Removal" earlier in this section.

### INSTALLATION

On vehicles equipped with a flexible dump hose:

1. Position hose through hole in frame crossmember, and support bracket.

2. Slide end of hose over drain valve and secure with hose clamp.

3. Secure with hose clamp at center support bracket.

**NOTE:** On vehicles equipped with a rigid dump tube assembly refer to "Fullway Valve-Installation" earlier in this section.

## SEWER HOSE ASSEMBLY

### REMOVAL

1. Remove sewer hose from its storage tube.

2. Remove bumper bolts attaching storage tube to bumper.

3. Remove end mounting bracket by removing inside energy absorber mounting bolts.

## INSTALLATION

1. Install end mounting bracket and retain with inside energy absorber bolts.

2. Fasten storage tube to bumper with bumper bolts.

3. Install sewer hose in storage tube and fasten to end mounting bracket.

## DRAIN PIPES AND FITTINGS

All drain pipes and fittings are made from ABS plastic. Repair is easily made using a hacksaw to cut out damaged portion of pipe and replace the pipe and connect it into the system with unions. Fittings (elbows, unions, "T's", etc.) may be more difficult to replace and some rerouting may be necessary. Follow the adhesive manufacturers recommendation for preparing the pipe and fittings for assembly.

"P" traps are easily removed for cleaning if they become clogged. To remove a "P" trap loosen compression fitting on either end of the trap as shown in Figure 6. Clean trap as required and position in vehicle and tighten compression fitting by hand.

## VENT LINE ROOF CAPS

Model 230 has two (2) vent lines serving the drainage system (See figure 1). Model 260 has three (3) vent lines. Each vent line has a roof mounted cap to help prevent anything from entering the system from the roof which may plug the vent line.

## REMOVAL

1. Drill off heads of rivets.

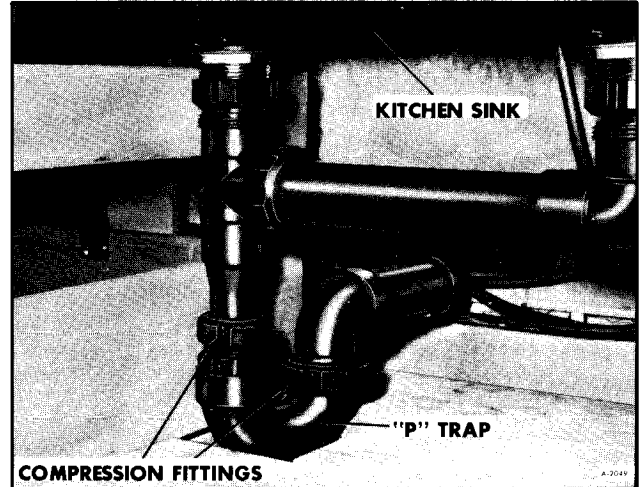

Figure 6--"P" Trap (Typical)

2. Remove vent cap and gasket.

## INSTALLATION

1. Replace gasket and vent cap. Check for proper fit, add sealer to gasket (both sides) if required.

2. Pop-rivet vent cap to roof.





# SECTION 24M THERMASAN SYSTEM

Contents of this section are listed below:

SUBJECT	PAGE NO.
General Information .....	24M-1
Trouble Diagnosis .....	24M-3
Waste Pump Repair .....	24M-6

## GENERAL INFORMATION

### SYSTEM OPERATION

The Thermasan System is a waste destruction system that eliminates the inconvenience of holding tank evacuation stops. A chemical reaction occurs first in the contents of the holding tank. This waste is then pumped into the engines exhaust system through an ejection orifice. The waste is destroyed to the extent that all remaining gaseous by-products are rendered invisible, bacteria free, harmless and meet emission requirements of Public Health and Federal Emission Standards. The system is not designed to empty the holding tank but lower the level to a point where frequent holding tank dumpings are minimized.

To operate the Thermasan System, two factors must be present:

1. Exhaust temperature of at least 900-1000°F.
2. Vehicle speed must exceed 35 mph. Operation of the control panel without these factors being present will not start the system. If the exhaust temperature should drop below limits, or if vehicle speed is reduced, system operation will be temporarily interrupted.

### CONTROL PANEL OPERATION

The thermasan controls are located to the right of the steering column in the driver's compartment. The panel face contains an "ON/OFF" switch, and three indicator lights. The "ON/OFF" switch contains a rheostat control for dimming if desired during night operation and a "PULL TO TEST" feature for testing pump operation.

When switched to the "ON" position, the green "READY" indicator will light. This is an indication that the system is operational. When the speed and temperature requirements are met, the red "REACTION" indicator will light, indicating physical destruction of waste if present. When the white indicator light is lit, the system has destroyed all

waste available and should be turned "OFF". When the "ON/OFF" switch is in the "ON" position and is pulled out, this will produce flashing of the "REACTION" light indicating actual pump operation and waste ejection.

The system operates on 12-volts DC and will destroy up to five gallons of waste per hour (For wiring diagram see figure 3).

**CAUTION:** *Do not put any combustible material such as kerosene, alcohol, or gasoline in the holding tank as this could result in system damage.*

Do not winterize the Motor Home with fuel oil or kerosene, which might get into the holding tank. We also recommend that facial type tissue be kept from the holding tank because it has "wet strength" which will not properly dissolve for passage through the waste pump. Toilet paper **MUST BE** water soluble.

Occasional draining of the holding tank at an approved dumping station is recommended. This should be done once or twice annually to remove any foreign particles or insoluble matter.

### SYSTEM COMPONENTS

The Thermasan System contains six basic components (Refer to figure 1):

1. pump
2. control panel
3. speed switch
4. heat switch
5. holding tank
6. ejection orifice

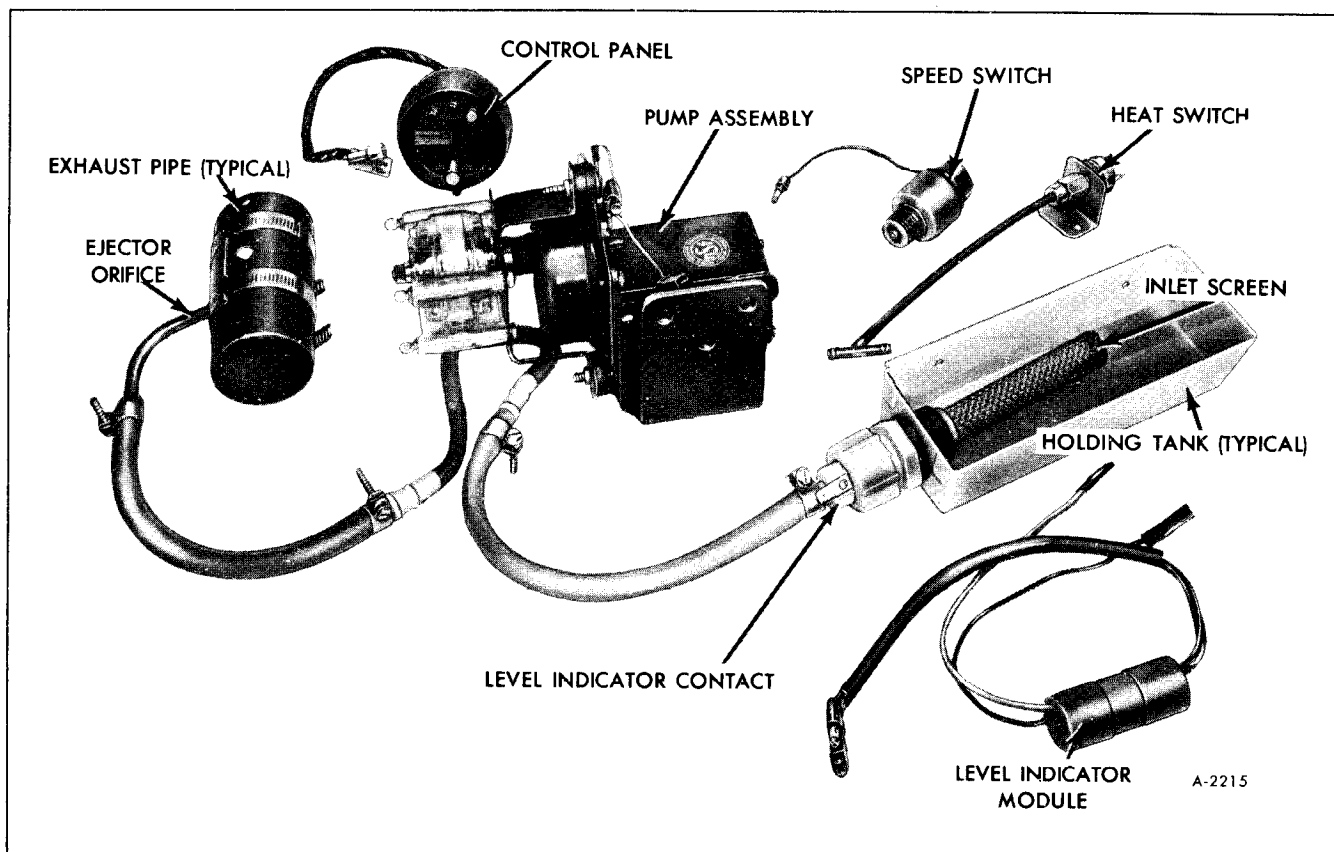

Figure 1—Thermasan Components

## WASTE PUMP

The pump, is basically a windshield wiper motor connected to a tube pump which moves the liquid wastes from the holding tank to the vehicle exhaust pipe. When the system is turned "ON" and operating conditions are met, the pump will force waste material into the vehicles exhaust system until the holding tank level is below the pick-up screen. At that time the "EMPTY" light will come on and the system should be turned "OFF".

After the "EMPTY" light first comes on, due to remaining tank material slosh, it will probably flicker for another 1/2 hour of operation. The remaining waste material can be removed by manually dumping holding tank, however it is not necessary that the tank be completely empty. By leaving an amount of liquid material in the tank, it prevents hardening of remaining material.

## CONTROL PANEL

The control module is used to provide the operator, at a glance with what the waste disposal system

is doing and when the system should be turned off. The control module lights are the replaceable type and should be checked first when the system operates abnormally. The "PULL TO TEST" feature of the control panel, meters the waste pump breaker points which open and close the "REACTION" light circuit. The system will operate the same whether the "ON/OFF" switch is in or out. The ON/OFF switch also controls "READY" and "REACTION" light intensity by rotating the knob.

## SPEED SWITCH

The speed sensor provides a ground for the ejection pump circuit when the vehicle speed is 35 mph or more. The switch is driven off the transmission and works in conjunction with the heat switch to allow the "REACTION" light to glow.

## HEAT SWITCH

The exhaust temperature switch used on the Thermasan System is a normally open vacuum

switch which is calibrated at 16 1/2-inches vacuum. When the engine vacuum drops below the 16 1/2-inch limit the switch contacts complete the pump circuit providing vehicle speed is 35 mph or more.

With 16 1/2-inches or less vacuum, engine exhaust temperature is above the 900°F requirement. The vacuum switch is wired in series with the speed switch and both must provide circuit continuity for system operation.

## HOLDING TANK

The waste pump is fed from the holding tank through a screen which filters out any insoluble waste material. This screen is completely removable by disconnecting the waste pump feed line at the

tank and pulling the screen out. The coupled end of the feed hose from the pump houses the low level contacts which activate the control module "EMPTY" light.

## EJECTION ORIFICE

The ejection orifice is located just behind the transmission and ahead of one of the vehicle mufflers. It consists merely of a tube connected to the pump by a high temperature hose to resist high temperatures developed.

Clamped connections should be checked when dripping or leaking occurs when the system is operating.

# TROUBLE DIAGNOSIS

## CHECK OUT PROCEDURE

To check the operation of the control panel and waste pump, the following procedure can be used.

1. Disconnect the white connector from the heat switch.

2. Connect a jumper to ground from the heat switch terminal.

3. With the control panel switched to the "ON" position the green "READY" light will light and the red "REACTION" light will come on and the pump will run.

4. If the holding tank is empty the "EMPTY" light should come on.

5. When the "ON/OFF" switch is pulled out the red "REACTION" light should flash intermittantly if the pump is working.

With the system connected but not operating as explained above, the following conditions should be checked for problem source:

## READY OR REACTION LIGHTS DO NOT GLOW WHEN SYSTEM IS TURNED ON

1. Inspect the power feed connection at the vehicle positive battery stud located on the bulkhead panel behind the right hand access door.

2. Remove and inspect the in-line fuse on the red lead near the battery stud connection. If this fuse is blown, it indicates a possible short in the entire Thermasan harness and its' connections should be inspected for possible frayed or burned wires or loose connections allowing a short to ground.

**NOTE:** DO NOT replace the 5 amp fuse until the harness has been inspected and under no circumstances should a larger amperage fuse be used.

3. Check the connector between the harness and control panel for proper connections. The male and female pins housed within the connector body should be straight and of equal height. They should be firmly attached to their respective wires (See figure 2).

When inspection is completed carefully mate the connector bodies and press firmly until the snap tabs are locked into place.

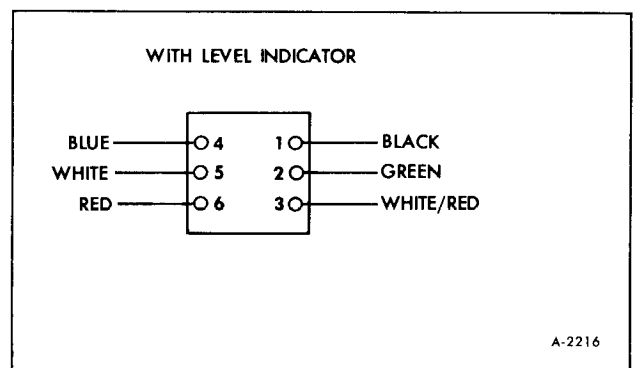

Figure 2—Control Panel Connector

4. Test the switch and its connections for defects.

a. Remove the set screw from the side of the base on the control panel. Slide the control panel off its base by exerting a firm forward pull.

b. Remove the screw from the back of the control panel and separate the housing from the bezel. Using a test lamp for locating shorts, check the switch. By reversing the steps above, reinstall the control panel.

### **READY LIGHT WORKS, REACTION LIGHT DOES NOT LIGHT ABOVE 35 MILES PER HOUR**

1. Check for a burned out bulb and/or loose connections.

2. Inspect the connector between the harness and the control panel.

3. Check the heat switch leads for loose connections at the terminals.

4. Test for a possible faulty control panel relay.

a. Disconnect the blue lead from the harness to the heat switch.

b. Turn the system on and ground the lead to any clean unpainted part of the frame.

c. If the ready light does not come on, the relay is faulty. Replace the control panel.

5. Test for a possible faulty heat switch.

a. Turn the system on with the engine not running ground the blue lead from the heat switch to the speed switch.

b. If the system does not operate the heat switch is at fault. Replace the heat switch.

6. If after testing for above conditions, the system does not operate at 35 mph, the problem lies with the speed switch and it must be replaced.

a. Remove the speedometer cable from the speed switch and disconnect its electrical fitting.

b. Unscrew the speed switch and replace it with a new part by reversing this procedure.

### **BOTH LIGHTS WORK, BUT UNIT DOES NOT SEEM TO PUMP WASTE**

1. Pump motor leads may be disconnected.

a. Remove the (2) pan head screws holding the terminal dust cover in place.

b. Check the terminals and their leads for a faulty connection.

c. Inspect the connections in the plastic pin housing that plugs into the dust cover.

d. Install cover and replace screws.

2. Inspect all waste lines for possible kinks.

3. Inspect all waste lines for possible plugs. Clean by using compressed air or a steel rod to force plug from hose if present. In the case where a line blockage has caused hose rupture within the pump, refer to "Pump Repair."

4. Check the holding tank evacuation probe (inlet screen) and inspect it for possible clog (See figure 1).

a. Remove the evacuation probe inlet screen by unscrewing the plastic nut on the outside of the holding tank.

b. If the system has a level indicator, note alignment of the terminals.

c. Flush the screen to remove the plugging.

d. Reinstall the screen, washer and nut.

e. Align level indicator connectors. They should be at 45° to the pavement.

**NOTE:** Either lead can be placed on the right or left terminals.

f. Inspect all hose clamps for possible air leaks.

### **REACTION LIGHT STAYS ON EVEN WHEN DECELERATING**

This indicates a faulty heat sensor and it should be replaced.

### **BOTH READY AND REACTION LIGHTS FLICKER ON AND OFF**

1. If the lights flicker at a constant rate, the prob-

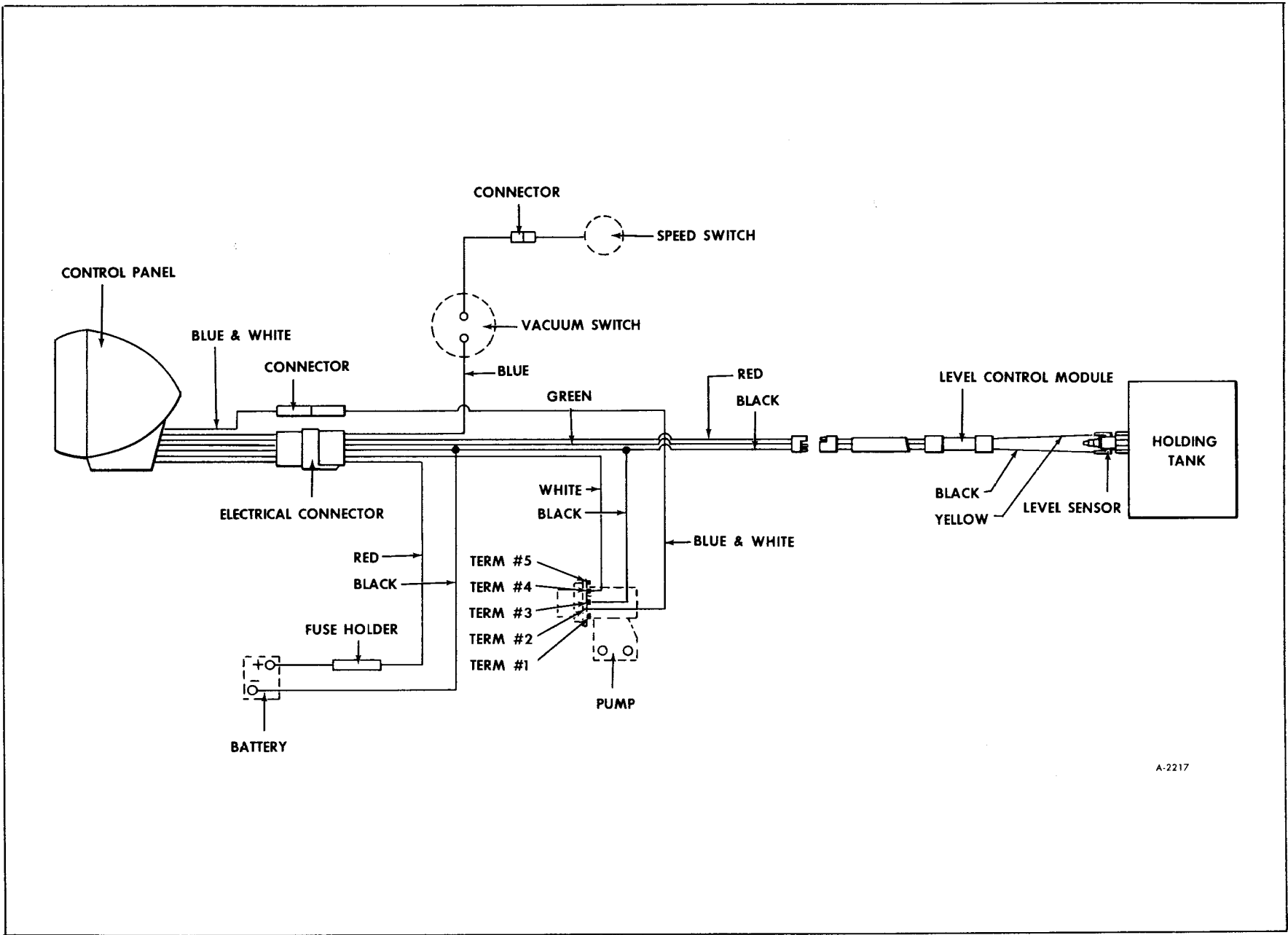

A-2217

Figure 3-Thermasan Wiring

lem may be in the "PULL TO TEST" circuit. Check the leads for a broken solder joint. If none is indicated replace control panel.

2. If the wiring harness ground is not connected, the ready and reaction lights may flicker. Inspect the contact of the black wire at the battery.

### **GREEN LIGHT FLICKERS ON AND OFF**

Check for possible loose lead at the light, on/off switch or power source. Check and secure all connections.

### **REACTION LIGHT FLICKERS ON AND OFF WHEN OPERATING CONDITIONS PERMIT SYSTEM OPERATION CONTINUOUSLY**

1. If the flicker is constant, the speed sensor is faulty. Replace the speed sensor.

**NOTE:** When tightening the speed sensor to the transmission, 1/4 turn past finger tight is sufficient.

2. If the flicker is intermittent type, a loose connection is at fault.

a. Inspect the blue wire to the heat switch and speed switch for a possible short or incomplete connection.

b. Check six pin plastic connector near the control panel (figure 2) and inspect the pins to be certain they are seated properly and making good connection.

### **READY AND REACTION LIGHT WORK BUT DO NOT PULSE WHEN "PULL TO TEST" IS SWITCHED**

1. Check the (1) pin connector near the control panel.

2. Inspect the blue/white wire at the pump for proper connection.

3. Remove the control panel and check the ON-OFF switch for broken or poor solder joints.

### **EMPTY LIGHT DOES NOT GO OFF**

1. This is normal system operation, indicates the holding tank level is below the probe.

2. If the light is on and visual inspection indicates the tank is full, then:

a. Inspect the black and yellow connections to the evacuation probe.

b. Test for a possible defective level indicator module. Remove the yellow lead to the evacuation probe. Jump the yellow wire to the black wire. If the light remains on, replace the level indicator module.

## **WASTE PUMP REPAIR**

The pumping tube used in the waste pump should be checked at 500 operational hour intervals for possible tube fatigue. In the case of tube rupture, the following procedure should be used to replace hose:

1. Disconnect battery ground cables. Remove the pump cover by removing the 2 thumb screws which hold the pump cover to the mounting bracket. The pump body and roller assembly will remain attached to the mounting bracket.

2. Holding the roller assembly in position, remove the defective hose. Should the roller assembly release from the pump body, return it to position making sure that the drive key on the motor shaft lines up with the key slot in the end of the roller shaft assembly. This will allow the roller to drop into position.

3. Take the new hose and insert it between the rollers and the pump body. Stretching the hose makes it slide easier into position.

4. Re-assemble the pump. Make sure the cover fits snugly against the pump body. Do not pinch the hose.

5. Tape the two hoses together just below the pump outlet with plastic electrical tape.

6. When placing the pump in the vehicle, make sure that the correct hose is coupled to the line from the holding tank.

7. Connect battery ground cables and check system for proper operation.



# SECTION 24N

## CABINETS AND FURNITURE

### GENERAL INFORMATION

The various cabinetry and furnishings in the GMC Motor Home can be readily replaced or repaired using standard wood-working procedures. Generally these units are retained by small screws, standard fasteners, etc. When removing any unit de-

termine the manner of attachment, note the alignment points, and before removing the last fastener, support the weight of the unit to avoid possible damage.

## CARE AND CLEANING

Dust and loose dirt that accumulate on interior fabric trim should be removed frequently with a vacuum cleaner, whisk broom or soft brush. Vinyl or leather trim should be wiped clean and a damp cloth. Normal cleanable trim soilage, spots or stains can be cleaned with the proper use of trim cleaners available through General Motors Dealers or other reputable supply outlets

**IMPORTANT:** Do not use commercial paint, chrome or glass cleaners on interior bright trim or painted surfaces. If cleaning is required, lukewarm water and a neutral soap may be used.

Before attempting to remove spots or stains from upholstery, determine as accurately as possible the nature and age of the spot or stain. Some spots or stains can be removed satisfactorily with water or mild soap solution (refer to "Removal of Specific Stains" later in this section). For best results, spots or stains should be removed as soon as possible.

Some types of stains or soilage such as lipsticks, some inks, certain types of grease, mustard, etc., are extremely difficult and, in some cases, impossible to completely remove. When cleaning this type of stain or soilage, care must be taken not to enlarge the soiled area. It is sometimes more desirable to have a small stain than an enlarged stain as a result of attempted cleaning.

**CAUTION:** When cleaning interior do not use volatile cleaning solvents such as: acetone, lacquer thinners, enamel reducers, nail polish removers; or such cleaning materials as laundry soaps, bleaches or reducing agents (except as noted in the instructions on "Cleaning Fabrics" and "Removal of Specific Stains.") Never use carbon tetrachloride, gasoline, or naphtha for any cleaning purpose. The above materials may be toxic or flammable, or may cause damage to interior.

## LAP BELT CARE

- Clean only with mild soap solution and lukewarm water.
- Do not bleach or dye belts since this may severely weaken them.

## INTERIOR GLASS

The interior glass surface should be cleaned on a periodic basis for continued good visibility. A commercial household glass cleaning agent containing

ammonia will remove normal tobacco smoke and dust films sometimes caused by ingredients used in vinyls, plastics, or other interior trim materials.

## KITCHEN SINK

The stainless steel sink should be cleaned with a liquid or finely ground powder. Scouring powder is not recommended for stainless steel and will ruin the finish. Stainless steel cannot be harmed by boiling water. However, salt, mustard, mayonaise and catsup will cause pitting and should be cleaned off immediately.

## CLEANING FABRICS

**IMPORTANT:** Be sure vehicle is well ventilated while using the following cleaning agents. Follow manufacturer's recommendations in using such products.

### CLEANING FABRICS WITH CLEANING FLUID

This type of cleaner should be used for cleaning stains containing grease, oil, or fats. Excess stain should be gently scraped off trim with a clean dull knife or scraper. Use very little cleaner, light pressure, and clean cloths (preferably cheesecloth). Cleaning action with cloth should be from outside of stain towards center and constantly changing to a clean section of cloth. When stain is cleaned from fabric, immediately wipe area briskly with a clean absorbent towel or cheesecloth to help dry area and prevent a cleaning ring. If ring forms, immediately clean entire area of panel section of the trim assembly.

**NOTE:** Sometimes a difficult spot may require a second application of cleaning fluid followed immediately by a soft brush to completely remove the spot.

### CLEANING FABRICS WITH DETERGENT FOAM CLEANERS

This type of cleaner is excellent for cleaning general soilage from fabrics and for cleaning a panel section where a minor cleaning ring may be left from spot cleaning. Vacuum area to remove excess loose dirt. Always clean at least a full trim panel or section of trim. Mask adjacent trim along stitch or weld

lines. Mix detergent type foam cleaners in strict accordance with directions on label of container. Use foam only on a clean sponge or soft bristle brush – Do not wet fabric excessively or rub harshly with brush. Wipe clean with a slightly damp absorbent towel or cloth. Immediately after cleaning fabric, dry fabric with a dry towel or hair dryer. Rewipe fabric with dry absorbent towel or cloth to restore the luster of the trim and to eliminate any dried residue.

## REMOVAL OF SPECIFIC STAINS

**CANDY**-Chocolate, use cloth soaked in lukewarm water; other than chocolate, use very hot water. Dry if necessary, clean lightly with fabric cleaning fluid.

**CHEWING GUM**-Harden gum with ice cube and scrape off with dull knife. Moisten with fabric cleaning fluid and scrape again.

**FRUIT STAINS, COFFEE, LIQUOR, WINE, SOFT DRINKS, ICE CREAM AND MILK**-Wipe with cloth soaked in cold water. If necessary, clean lightly with fabric cleaning fluid. Soap and water is not recommended as it might set the stain.

**CATSUP**-Wipe with cloth soaked in cool water. If further cleaning is necessary, use a detergent foam cleaner.

**GREASE, OIL, BUTTER, MARGARINE AND CRAYON**-Scrape off excess with dull knife. Use fabric cleaning fluid.

**PASTE OR WAX TYPE SHOE POLISH**-Light application of fabric cleaning fluid.

**TAR**-Remove excess with dull knife, moisten with fabric cleaning fluid, scrape again, rub lightly with additional cleaner.

**BLOOD**-Wipe with clean cloth moistened with cold water. Use no soap.

**URINE**-Sponge stain with lukewarm soap suds from mild neutral soap on clean cloth, rinse with cloth soaked in cold water; saturate cloth with one part household ammonia and five parts water, apply for one minute, rinse with clean, wet cloth.

**VOMITUS**-Sponge with clean cloth dipped in clean, cold water. Wash lightly with lukewarm water and mild neutral soap. If odor persists, treat area with a water-baking soda solution (one teaspoon baking soda to one cup of lukewarm water). Rub again with cloth and cold water. Finally, if necessary, clean lightly with fabric cleaning fluid.





# SECTION 24P EXHAUST VENTS DESCRIPTION

The GMC Motor Home is equipped with a number of exhaust vents, these include:

- The range/oven power hood vent to remove cooking odors and gases. The switch is on the fan.
- The power bath vent for ventilation. The control switch is on the vent.
- One or two ceiling vents (depending whether the vehicle is equipped with roof mounted air conditioning) to allow warm air to escape that may accumulate at ceiling level when the vehicle is parked in the sun. The opening of a ceiling vent and a window will aid in removing condensation from the windows.

The vents are crank-operated from inside the Motor Home. In rainy weather it is possible to leave the ceiling vents open slightly for ventilation without entry of water into the Motor Home (depending upon the magnitude and direction of rain).

**NOTE:** All windows and roof vents must be tightly closed when operating the air conditioner or furnace to obtain maximum cooling or heating.

Power fans are available for the ceiling vents. These will increase the efficiency of the vent. They are operated by the button switch at the corner of the vent.

## VENT MOTOR DIAGNOSIS

The range/oven exhaust vent fan, the bath exhaust vent fan, and the ceiling vents with power fans are all operated by 12-volts living area electricity. Should any of these fans refuse to work make sure the living area battery is not dead. Next check the fuses in the living area electrical compartment, then

check to see that the motor is receiving power through the switch at the motor. If power is available at the motor but it still refuses to work remove the motor and test it on a direct 12-volt source. Replace motor if necessary.

## RANGE / OVEN EXHAUST VENT

### MOTOR REPLACEMENT (FIGURE 1)

#### REMOVAL

1. Remove retaining nuts at light and fan switch on bottom of exhaust hood.
2. Remove exhaust hood bottom assembly.
3. Remove two nuts holding motor mount to vent housing.
4. Disconnect motor wire.

5. Remove motor mount and fan from motor.

#### INSTALLATION

1. Install fan and mount to motor.
2. Connect motor wire to switch wire.
3. Install motor and mount assembly to vent housing and secure with two nuts.
4. Position exhaust hood bottom assembly to bottom of exhaust hood and secure with retaining nuts at switches.

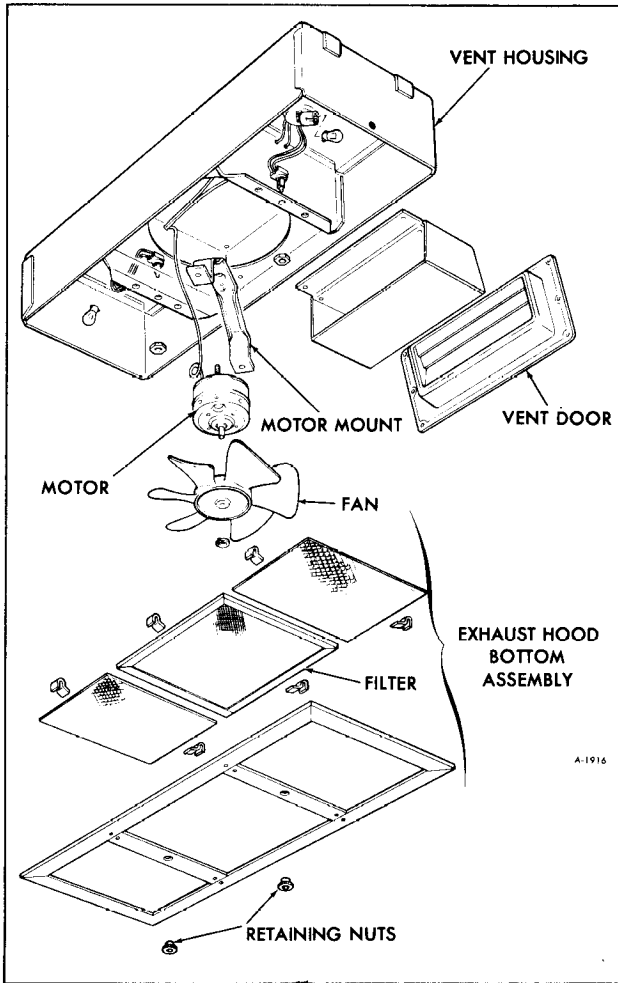

Figure 1-Range Power Vent

## RANGE/OVEN VENT FILTER (SEE FIGURE 1)

It is important that the power range hood filter be inspected frequently and cleaned as needed. To clean filter, remove retaining nuts at power hood switches, remove filter and wash in hot, soapy water. Rinse thoroughly and reinstall.

## CEILING VENTS

### MOTOR REPLACEMENT (POWER VENTS) (FIGURE 2)

#### REMOVAL

1. Remove vent crank handle (one screw).
2. Remove vent screen (two screws).
3. Remove cover on switch box and disconnect motor wires.
4. Loosen cinching strap sufficiently to remove motor and fan assembly.
5. Remove fan from motor.

#### INSTALLATION

1. Install fan on motor.

2. Position motor and fan assembly in vent housing and secure in place with cinch strap.

3. Connect motor wires in switch box and install cover.

4. Install vent screen, secure with two screws.

5. Install vent crank handle.

### CRANK ASSEMBLY REPLACEMENT

#### REMOVAL (SEE FIGURE 2)

1. Partially open vent.

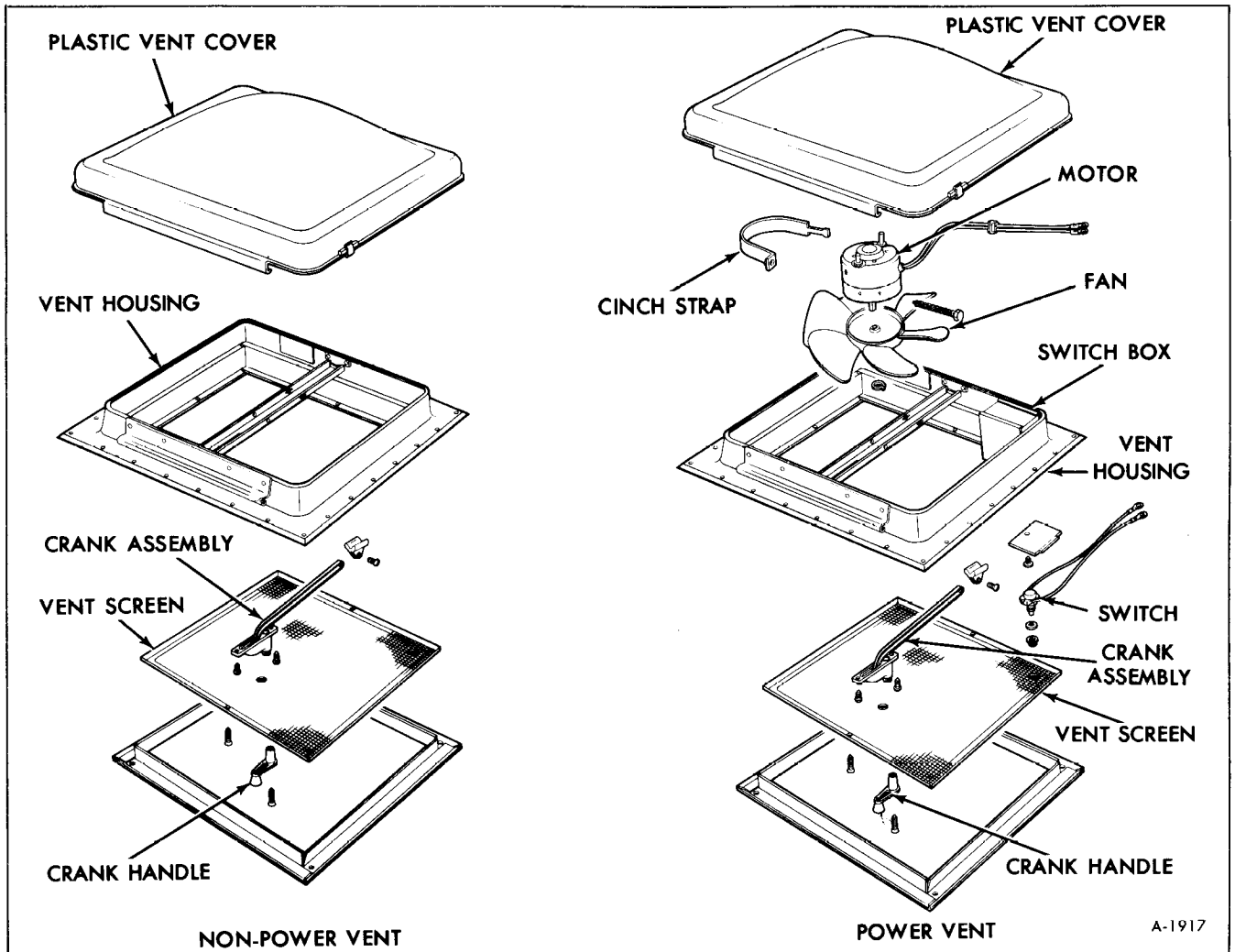

Figure 2-Ceiling Vents

2. Remove vent crank handle (one screw).
3. Remove vent screen (two screws).
4. Remove screw connecting crank lift arm to plastic slide.
5. Remove crank assembly from vent support bar (two screws).

### INSTALLATION

1. Position crank assembly through vent support bar, secure with two screws.
2. Connect crank lift arm to plastic slide with screw.
3. Install vent screen and secure with two screws.
4. Install crank handle.

## BATH VENT

### MOTOR REPLACEMENT (FIGURE 3)

#### REMOVAL

1. Remove vent ring in bath module (three screws).

2. On the roof of the vehicle remove the two screws holding plastic cover on vent.
3. Remove the entire vent assembly from roof by removing the six attaching screws pulling the unit out and disconnecting wires at quick disconnect.

## 24P- 4 EXHAUST VENTS

4. With the unit on the bench remove vent closing handle (two screws).
5. Remove filter (two screws & switch nut).
6. Remove two screws at each motor mount.
7. Remove the two nuts at motor mounting.
8. Carefully remove the motor mount brackets.
9. Remove spring clip assemblies.
10. Disconnect wires and remove motor. Pull fan from motor.

## INSTALLATION

1. Position motor with fan in housing and connect wires.
2. Position spring clip assemblies to motor studs.
3. Position motor mount brackets on motor studs and secure to vent housing with four screws.
4. Position switch on motor studs and secure motor to mounting bracket with two nuts and washers.
5. Install filter (two screws & switch nut).
6. Install closing handle (two screws).
7. Install vent assembly to roof being sure to use a sealing compound to prevent leaks.
8. Install plastic vent cover.

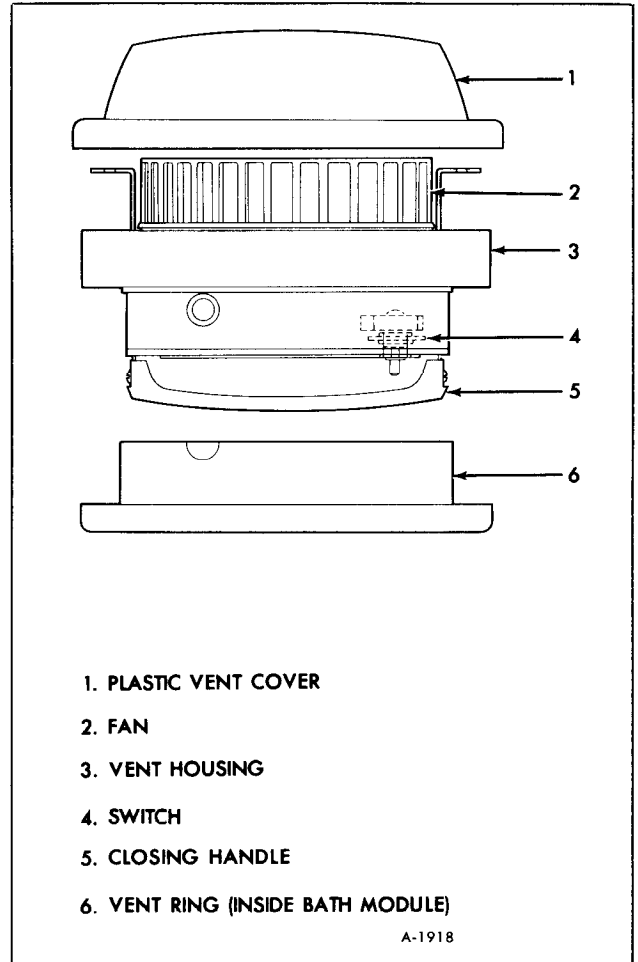

Figure 3-Bath Vent

9. Install vent ring inside of bath module.

# SECTION 24Q

## OTHER EQUIPMENT

### VACUUM CLEANER

#### GENERAL INFORMATION

The Motor Home integral vacuum cleaner (optional on Model 260) operates on 120-volt current. The vehicle must be connected to an external power source or the motor generator must be in operation in order to operate the vacuum cleaner.

Vacuum cleaner components are stored in the side of the refrigerator module near the entrance door. The vacuum cleaner storage cabinet contains a long flex hose, wand, and a wide assortment of wand attachments including one for shag carpeting (See figure 1).

To operate the vacuum system, remove flex hose from the cabinet, lift vacuum inlet hinge cap, just under the storage cabinet, and insert the proper end

of the flex hose (figure 2). At this point the vacuum system will be operating and is used in the same manner as any household vacuum cleaner.

#### BAG AND FILTER REPLACEMENT

The vacuum cleaner contains two filters – the bag which catches the dirt and a secondary filter to keep any residual dirt out of the motor.

1. To remove the filled filter bag, slide cardboard end of bag with rubber seal off intake tube. Pull bag forward and out of cabinet.
2. To replace filter bag, spread new bag and position in cabinet. Slide cardboard end with rubber seal up over intake tube by starting at back of tube and pulling forward and up.
3. The secondary filter is located at the top of the filter bag chamber. The secondary filter should be removed and cleaned often.

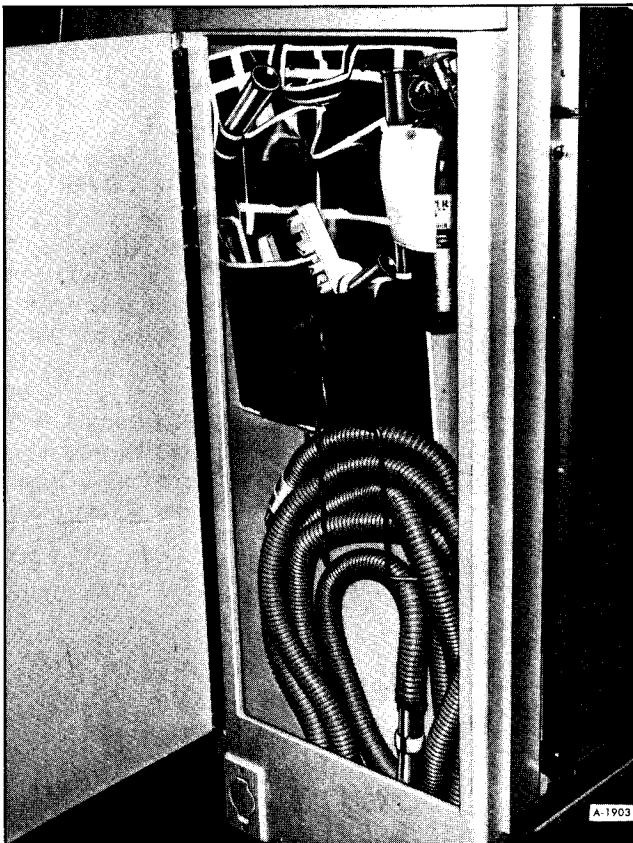

Figure 1-Vacuum Cleaner Components

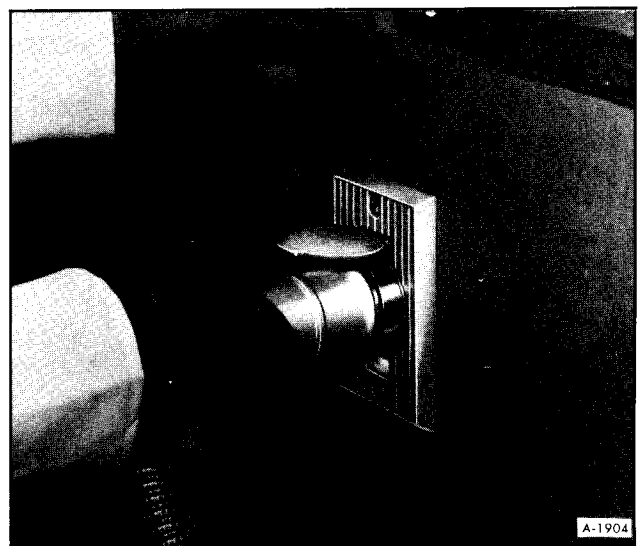

Figure 2-Connecting Flex Hose to Wall Inlet

## TROUBLE DIAGNOSIS

If the vacuum cleaner fails to operate the trouble lies in one of three areas; the power source, the low voltage switch system, or the vacuum cleaner motor. This is the order in which the trouble should be examined.

1. Check first that the Motor Home is receiving 120-volt power to the external power cord. Next check the circuit breakers in the living area electrical compartment. Finally make sure the vacuum cleaner is securely plugged into the receptacle under the refrigerator module.

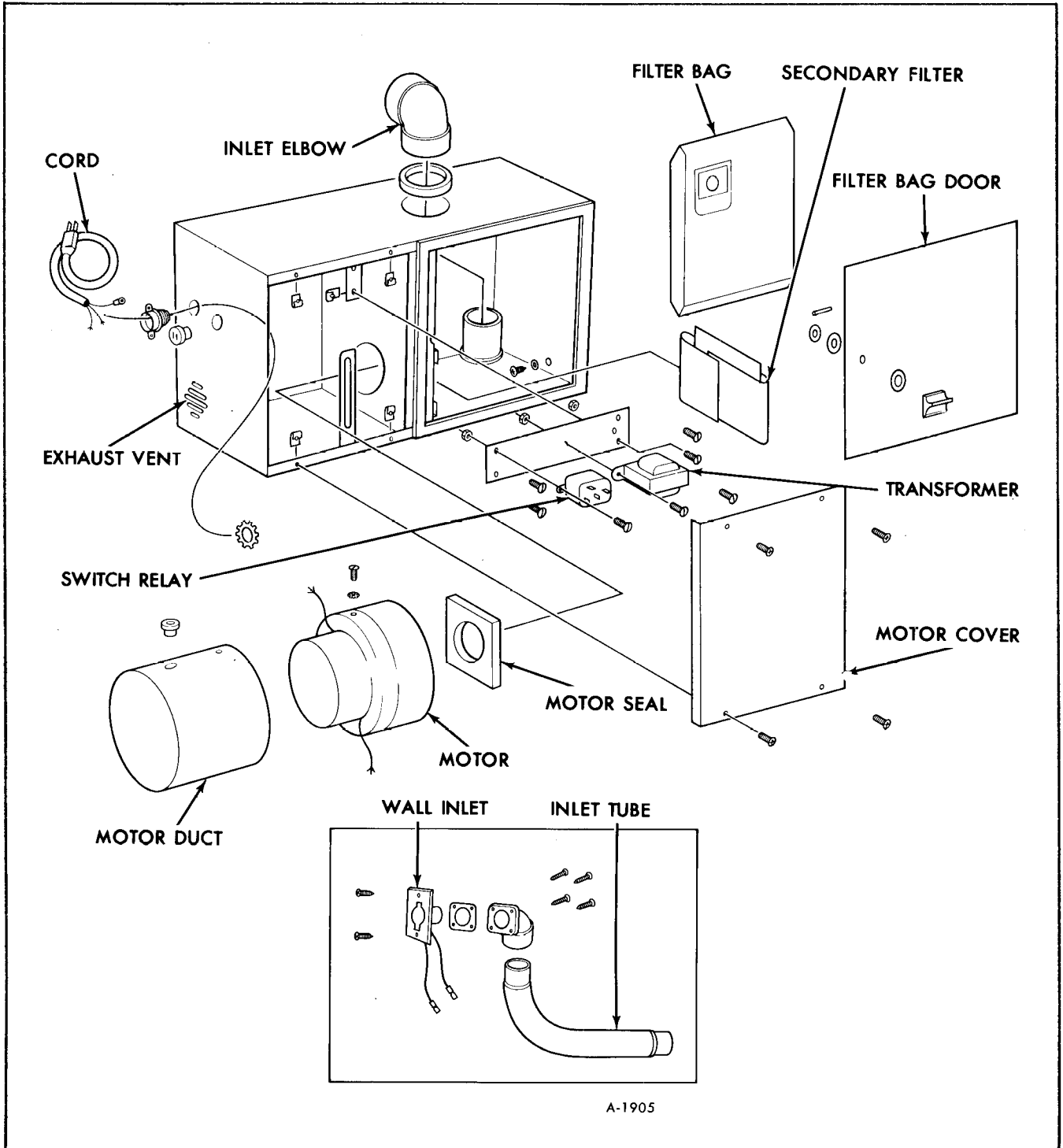

Figure 3-Vacuum Cleaner Components

2. Since the switch operates through two low voltage contacts in the hose inlet, the voltage should be checked here with a voltmeter at approximately 25-volts. If there is no voltage at these contacts, either the transformer is faulty or the wiring is loose. If there is voltage at these contacts:

a. Unplug the 120-volt motor wires at the relay (See figure 3).

b. Next insert hose end into vacuum inlet.

c. Now check for continuity at the two terminals on the relay where the motor wires were disconnected. If there is no continuity here the relay is faulty.

d. If there is continuity at these terminals the vacuum motor is faulty and must be replaced. See "Vacuum Motor Replacement".

## LOSS OF VACUUM

The reasons for loss of vacuum are usually simple and easily remedied. The following are the most common causes:

1. Hose may be obstructed. Remove from inlet. Insert a blunt object that is slightly smaller in diameter than the hose. A screwdriver (insert handle end first) or steel ball can generally be shaken through the hose to clear obstructions. A garden hose can also be used to clear vacuum hose.

2. Filter bag may be filled.

3. Door to filter area may be open or gasket surrounding door may be damaged. Door must be closed securely for efficient operation of the power unit.

4. Exhaust line may be clogged. Make a visual inspection of exterior opening. Check for lint clogging if a guard screen is being used. Clear exhaust with a probe while unit is running.

5. Something may be clogging the tube line. Start the unit, purge line by covering hose end with hand-release to send a sudden surge of air through.

## VACUUM MOTOR REPLACEMENT (FIGURE 3)

### REMOVAL

1. Unplug vacuum cleaner assembly from duplex receptacle.

2. Remove motor compartment cover (See figure 3).

3. Disconnect vacuum motor wires at relay and junction.

4. Remove screw at motor securing strap.

5. Remove motor and motor duct from cabinet (figure 3).

6. Remove motor from duct.

### INSTALLATION

1. Install motor in duct with motor wires properly routed.

2. Install motor and motor duct in vacuum cabinet making sure motor seal is properly positioned (figure 3).

3. Secure motor with motor securing strap and screw.

4. Connect motor wires at relay and junction.

5. Install motor cover.

6. Plug vacuum cleaner into receptacle and check operation.

# Wiring Diagrams

Living Area 12v DC  
Engine Area 12v DC