

Fan Belts

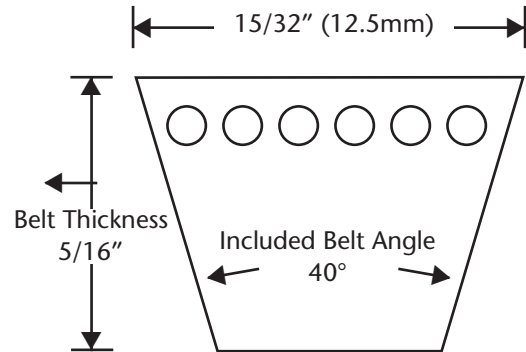
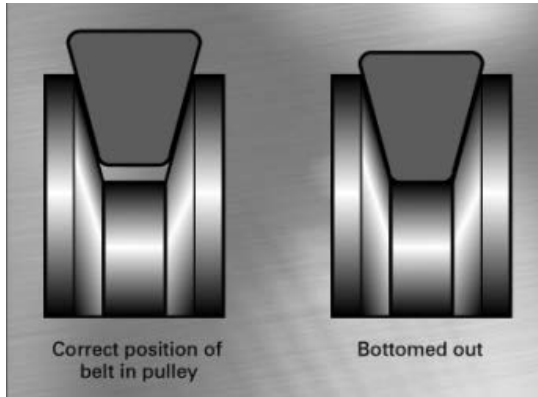

'Bottom-out'

When a V type belt becomes very worn, the bottom of the V shape may contact the bottom of the groove in the pulley, preventing the sides of the belt from making good contact with the sides of the pulley groove. This reduced friction causes slippage; a belt worn enough to bottom out should be replaced. The power transmission is meant to be from the sides of the belt. When installed, the belt should ride above the pulley. Otherwise, it is too narrow.

Our GMCs use '4L' FHP (*Fractional Horse Power*) belts. The width is measured in 32nds of an inch. Ours is nominally 15/32" wide (12.5mm to be exact). This 15/32" is measured at the intersection of the angle side of the belt and the top. Be aware that the belt might have had the top corner shaved off to prevent fraying. The first 2 numbers, 15, indicates the width. The next 3 numbers indicate the length of the "outside" circumference, last being in 10ths of an inch.

GMC Belts:

Alternator belt is 15570.

The "15" = 15/32" wide and 57.0" long.

Power Steering belt is 15540 which is 54" long.

Air Conditioner belt (455) is 15620 which is 62" long and 15600 (for the 403) which is 60" long.

With these measurements you should be able to get the correct belt at any automotive parts outlet.

Beware: The letter "V" in the belt number indicates a 30° V rather than the standard 40° V belt. This belt will not contact the pulley correctly and will fail prematurely. An "X" indicates the belt has notches on it which probably doesn't matter to us.

Industrial or Implement Belts

For Your Information

Generally, the 4L automotive belts are adequate for our needs. In some instances it has been found that a more substantial belt is required. Some GMCers have had good results with these belts that are designed to handle up to 4 times more horsepower than automotive belts.

Industrial belts use a lettering system for sizing specifications. The "A" size industrial belts are virtually the same dimensions as the "4L" belts our GMCs use but are built to more strict tolerances. If you decide to try an

"A" industrial belt, get them in about 1" shorter size. "A" belts are specified by the inside circumference rather than the outside as our "4L" belts are. Therefore, you must specify a belt that is approximately 2" shorter to allow for the thickness of the belt. Then, add 1" because of their fractionally greater width (1/64").

Therefore, the belts used in our GMCs would be:

Alternator – A56

Power Steering – A44

Air Conditioner – A61 *A59 for the 403 engine